



ACOUSTICS and Mass Timber

BEAUTY & ACOUSTICS in Mass Timber

Mass timber construction is revolutionizing the construction industry by increasing sustainability, decreasing construction time and labor requirements, and captivating occupants with its beauty. From Cross Laminated Timber (CLT) to Nail Laminated Timber (NLT), the mass timber category is rapidly gaining the attention of people across the globe. Its appeal is undeniable... the warmth of exposed wood panels gives occupants a connection to nature even while indoors.

When mass timber is left exposed as the ceiling, meeting the minimum code for sound transmission will be very difficult. Armstrong offers options to reduce sound transfer to meet or exceed the sound code minimum.

- ▶ Offers significant impact and airborne sound reduction
- ▶ Fast and easy installation
- ▶ Verified through sound testing
- ▶ Includes: Armstrong IIC Drywall grid and isolator, AcoustiBuilt® Seamless Acoustical Ceiling System, and Maxxon® Acousti-Mat® solutions

Connection to Nature Indoors



ACOUSTICS and MASS TIMBER

Section 1206 of the International Building Code (IBC) lists requirements for acoustical performance of floor/ceiling assemblies between adjacent dwelling and sleeping units or adjacent public areas such as corridors or service areas. These assemblies must have minimum Sound Transmission Class (STC) and Impact Insulation Class (IIC) ratings of 50. Occupancies such as offices, schools, and hospitals do not fall under the scope of these requirements, however acoustical performance guidelines still exist.

What is STC?

Sound Transmission Class

STC measures how effectively a wall or floor/ceiling assembly isolates airborne sound and reduces the level that passes from one side to the other. Examples of airborne sound include talking and sounds from a radio or television.



What is IIC?

Impact Insulation Class

IIC measures how effectively a floor/ceiling assembly blocks impact sound from passing through a floor/ceiling. Just as STC is a measure of airborne sound reduction, IIC is a way to quantify structure-born noise. Examples of impact sound include foot falls (walking/running/jumping) and objects dropping on the floor.



Trust Armstrong® Drywall Grid tested assemblies to meet or exceed IBC – STC/IIC sound isolation requirements

STC IIC PERFORMANCE GUIDELINES

Changes in STC/IIC Ratings	Description
+ / - 1	Almost perceptible
+ / - 3	Just perceptible
+ / - 5	CLEARLY PERCEPTIBLE
+ / - 10	Twice (or half) as loud

It is important to note that products do not receive STC or IIC ratings as stand-alone materials. These ratings are used to describe an entire assembly. The combination of multiple products and systems is what contributes to an effective floor/ceiling assembly.

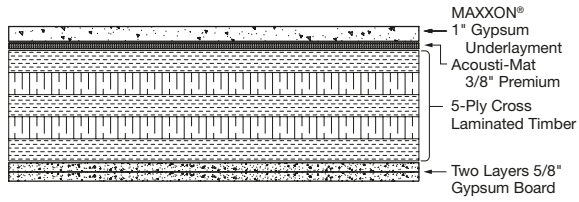

Assembly With No Suspended Ceiling

STC **IIC**
 52 46

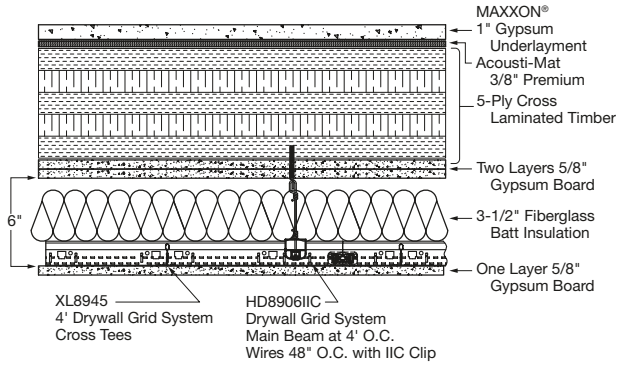

Suspended Ceiling With Gypsum Board

STC **IIC**
 63 60

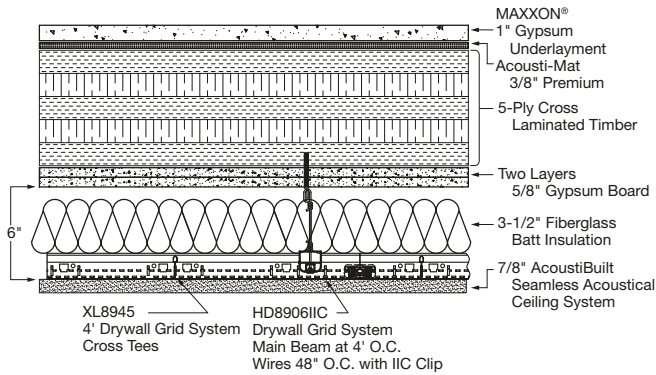

Suspended Ceiling With AcoustiBuilt®

STC **IIC**
 63 59



ACOUSTIBUILT® Seamless Acoustical Ceiling System

SOUND SOLUTION DETAILS

The AcoustiBuilt® seamless acoustical ceiling system looks and installs like drywall but has been engineered to absorb and block sound. AcoustiBuilt uses an acoustically transparent fine-texture finish applied in layers to allow sound to pass through and be absorbed by the mineral fiber panels. The AcoustiBuilt panels are attached to FrameAll™ Drywall Grid with adhesive and screws, then the ceiling is finished just like drywall.

▼ AcoustiBuilt Cloud Installation; REGENXBIO, Rockville, MD





DRYWALL GRID Sound Isolation Solution

DRYWALL/ STUCCO/PLASTER Flat Ceilings

Eliminate the labor-intensive cutting, tying, and spacing of track-and-channel framing. Our systems are engineered with rout locations and cross tees to maintain precise module spacing. Pre-notched main beams simplify curved drywall installations. FrameAll™ Drywall Grid solutions are manufactured to meet or exceed ASTM standards and code requirements, and are engineered to provide economical alternatives to stud-and-track construction. Create inspiring designs with Armstrong integrated linear lighting solutions for drywall and AcustiBuilt®.

▼ Linear Lighting for Drywall and AcustiBuilt®



Impact Isolation Clip, for use with HD8906IIC drywall grid main beam, provides IIC improvement in assemblies including Mass Timber to ensure your project meets IBC requirements.

Clip Color: Natural

IIC Clip must be used with HD8906IIC Drywall Grid Main Beam.

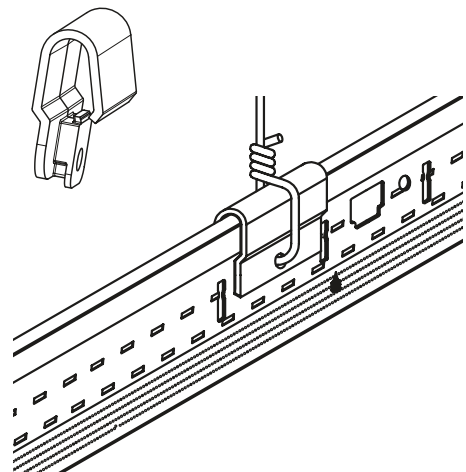

SYSTEM OVERVIEW

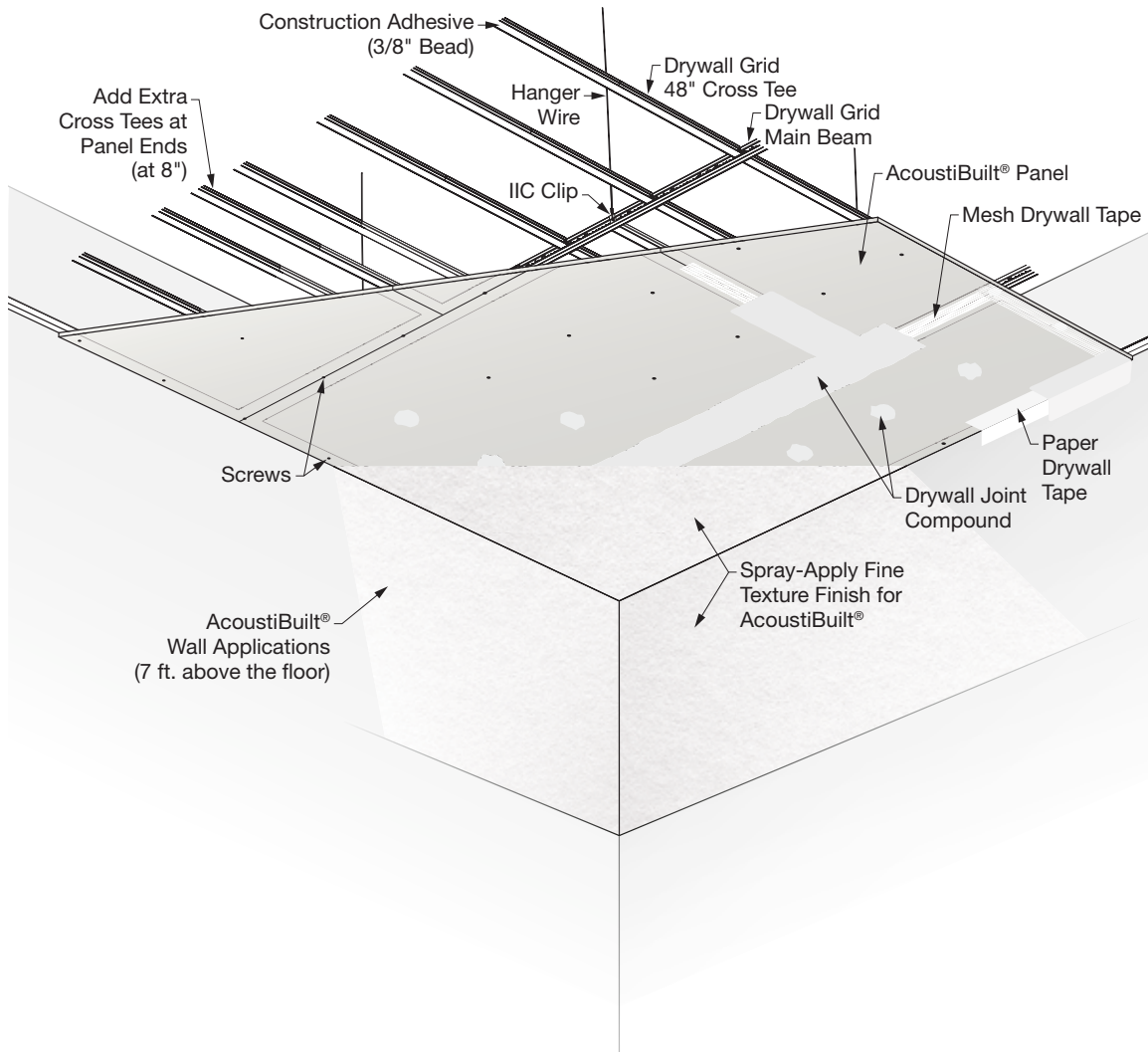

SOUND ABSORPTION COMPARISON

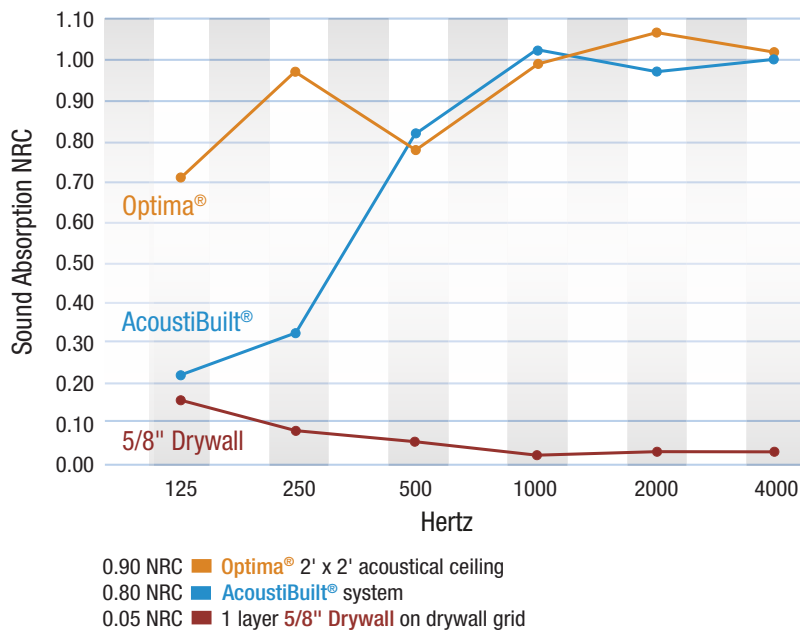

The AcoustiBuilt[®] seamless acoustical ceiling system combines excellent acoustical, sustainability, and MEP integration attributes for mass timber building applications. When installed with FrameAll™ Drywall Grid using the IIC clip you can achieve an excellent combination of sound absorption (NRC) and sound blocking (CAC) along with high performance airborne sound isolation (STC) and impact sound isolation (IIC) to meet or exceed international building code requirements.



▲ AcoustiBuilt Ceiling System; Marriott Marquis, New York, NY

ACOUSTIBUILT® VS. DRYWALL ACOUSTICAL COMPARISON

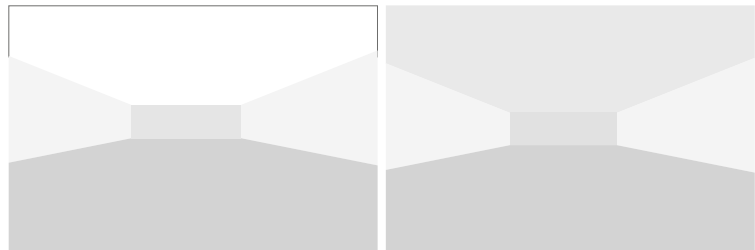

900 SF Hotel Room, 9' ceiling, drywall walls, commercial carpet	5/8" Drywall Ceiling	AcoustiBuilt Seamless Acoustical Ceiling System
CAC	50	48
STC (Mass Timber)	63	63
IIC (Mass Timber)	60	59
Sound Absorption	0.05	0.70
Reverberation Time	1.26	0.38
Total Acoustics®	N/A	BEST 🗣️

* 1.33 Sabins/SF achieved using infill panel item 8200T10

TAKE THE NEXT STEP

1 877 276-7876

Customer Service Representatives
7:45 a.m. to 5:00 p.m. EST
Monday through Friday

TechLine – Technical information, detail drawings,
CAD design assistance, installation information,
other technical services – 8:00 a.m. to 5:30 p.m. EST,
Monday through Friday. FAX 1 800 572 8324
or email: techline@armstrongceilings.com

armstrongceilings.com/commercial

Latest product news

Standard and custom product information

Online catalog

CAD, Revit®, SketchUp® files

A Ceiling for Every Space® Visual Selection Tool

Product literature and samples – express service
or regular delivery

Contacts – reps, where to buy, who will install

ProjectWorks™

armstrongceilings.com/projectworks

The power of ProjectWorks® Design and
Pre-Construction Service

Mix and match different sizes, shapes, colors,
and materials to reinvent your standard, specialty,
or custom ceiling.

Visit our pattern gallery online to see ideas for your
next project. armstrongceilings.com/patterngallery

Contact your local representative to get a
design started! Not sure who your local rep is?

Visit armstrongceilings.com/findarep

Revit® is a registered trademark of Autodesk, Inc.; SketchUp® is a registered trademark
of Trimble, Inc.; Maxxon® and Acousti-Mat® are trademarks of Maxxon, Inc.; all other
trademarks used herein are the property of AWI Licensing LLC and/or its affiliates
© 2022 AWI Licensing LLC Printed in the United States of America

armstrongceilings.com/dgs

 **Armstrong**®
CEILING SOLUTIONS