

CEILING CONSTRUCTION EXPERTISE

Inspiring Great Spaces™

Armstrong[®]
CEILING & WALL SYSTEMS

on the mark

Do you have questions about ceiling schedule, cost, or installation? Armstrong has the answers and ceiling construction expertise to keep your project on the mark.

AT A GLANCE

- NYSE: AWI
- Founded in 1860
- 2.6 billion in 2014 revenues
- 7,400 employees
- Headquarters: Lancaster, PA

PRODUCT PORTFOLIO

- Acoustical (Mineral Fiber and Fiberglass) Ceiling Systems
- Specialty and Custom Ceiling Systems
- Metal and Wood Ceiling Systems
- Acoustical and Drywall Suspension Systems
- Integrated Installation Systems

OPERATING PRINCIPLES

- Respect the dignity and inherent rights of the individual
- Maintain high moral and ethical standards and reflect honesty, integrity, reliability, and forthrightness
- Reflect the tenets of good taste and common courtesy
- Serve fairly and in proper balance the interests of all groups associated with the business



3

On Budget

Design tools you need to keep your project on budget

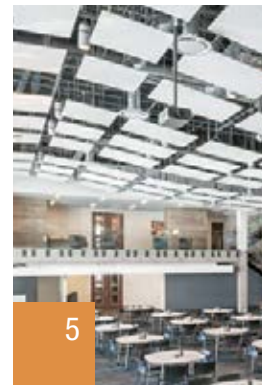

5

On Time

Integrated product design, manufacturing, and distribution



7

On the Mark

Technical expertise to get your project done right



WoodWorks® Torsion Spring Radial Ceiling System in Natural Variations™ Light Cherry; FedEx AOTC, Memphis, TN



9

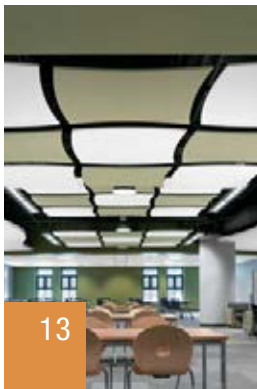

13

CEILING CONSTRUCTION Expertise

Solutions Portfolio
Pre-engineered ceiling solutions for every project

Sustainability
Green ceiling options for every space

for every space

With the right design tools and a broad assortment of ceilings for every space and budget, we can help you keep the “value” in value engineering.

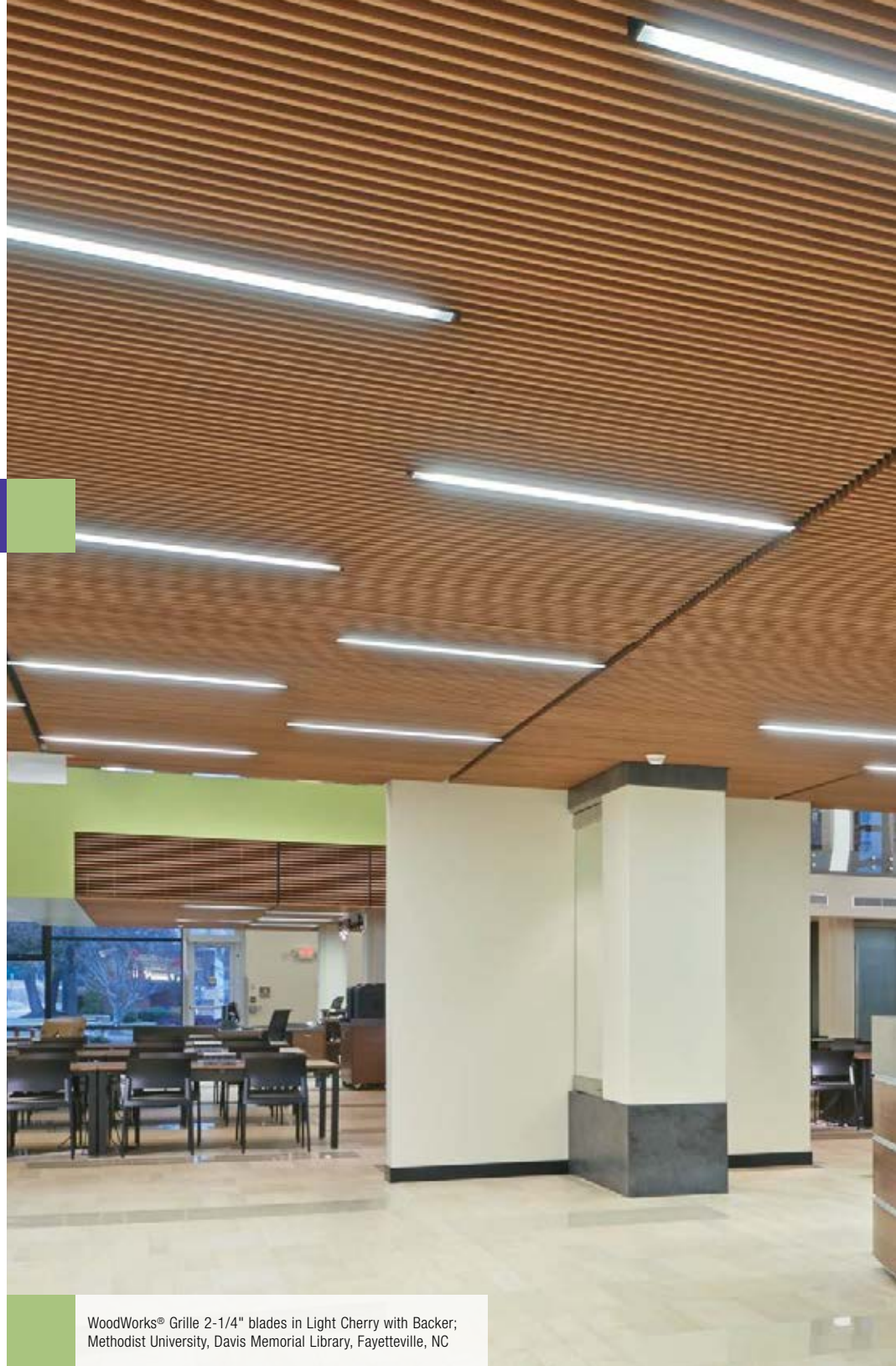

WoodWorks® Grille 2-1/4" blades in Light Cherry with Backer; Methodist University, Davis Memorial Library, Fayetteville, NC

ON BUDGET



CAD/REVIT DOWNLOAD CENTER

Download the CAD/Revit files you need to save time and reduce rework.

COMPETITIVE COMPARISON TOOL

Quickly find the best match for a competitive specification using our online Competitive Comparison Tool.

BUILD A SUBMITTAL

Fill out a simple online form and Armstrong will collect and ship all required literature, samples, and MSDS sheets.

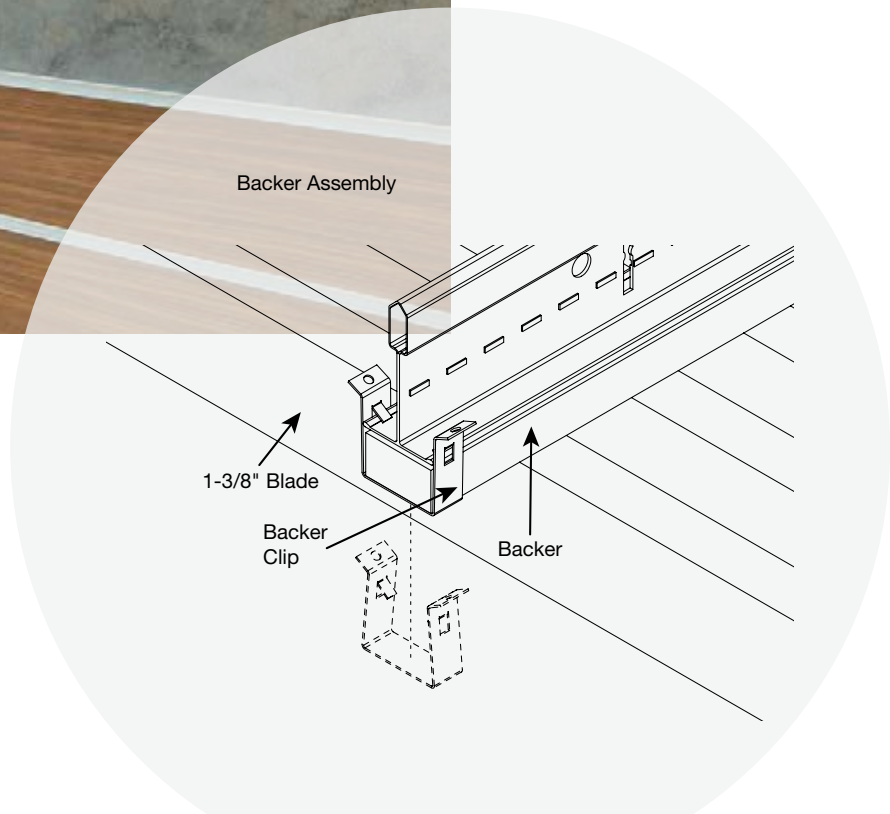

ON TIME

We can help you finish your project on time with pre-engineered ceiling systems, easier installation techniques, and the most complete integrated manufacturing and distribution network in the industry.

peace of mind



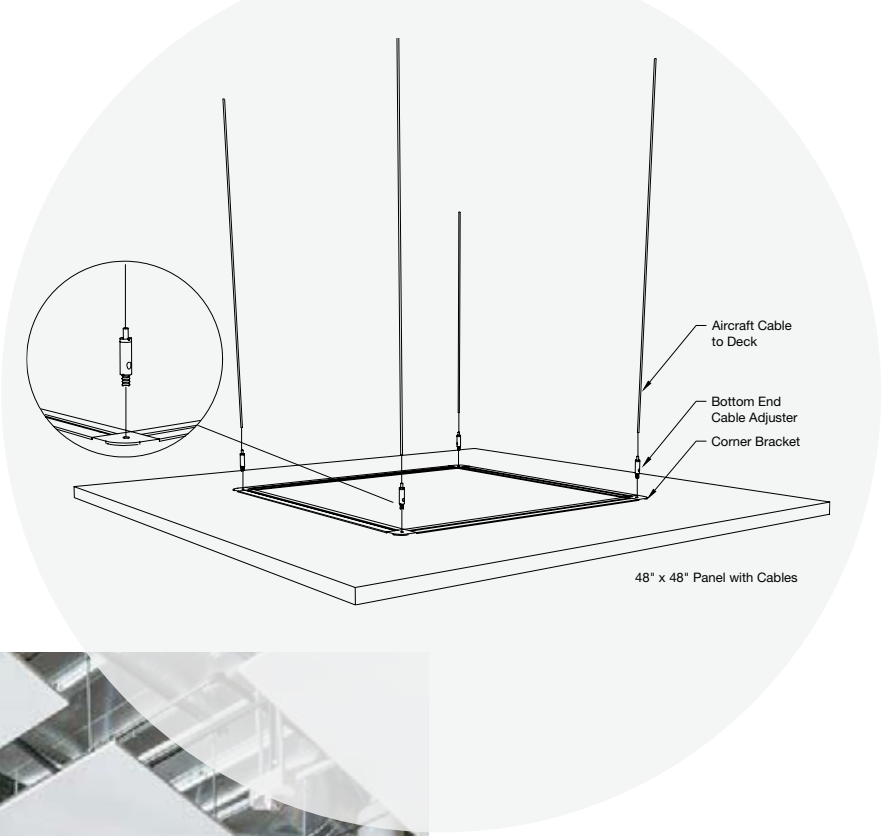

PRE-ENGINEERED SYSTEMS

Armstrong products are pre-engineered so every piece in the system is manufactured for speed, compatibility, and accuracy.

INSTALLATION TECHNIQUES

Our exclusive installation systems save time and often require less material and labor than traditional methods.

- Installation instructions
- Installation videos

BROADEST DISTRIBUTION NETWORK

With our comprehensive manufacturing and distribution network, you can depend on quick delivery of every item in our ceilings, suspension systems, and walls portfolio.

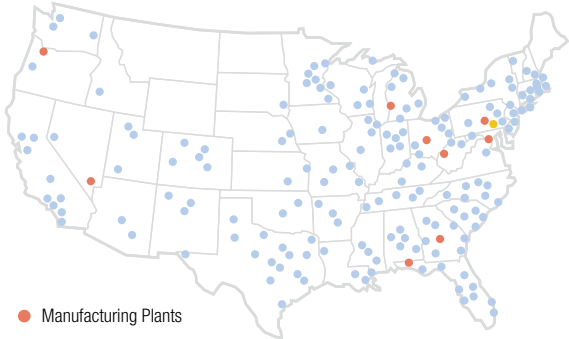

- Manufacturing Plants
- Distributor Locations
- Customer Focus Team and TechLine™ Support

ON THE MARK

there when you need us

In addition to pre-engineered accuracy and integrated compatibility, each ceiling solution we offer is backed by the best technical support in the industry – so you can finish every job on the mark.

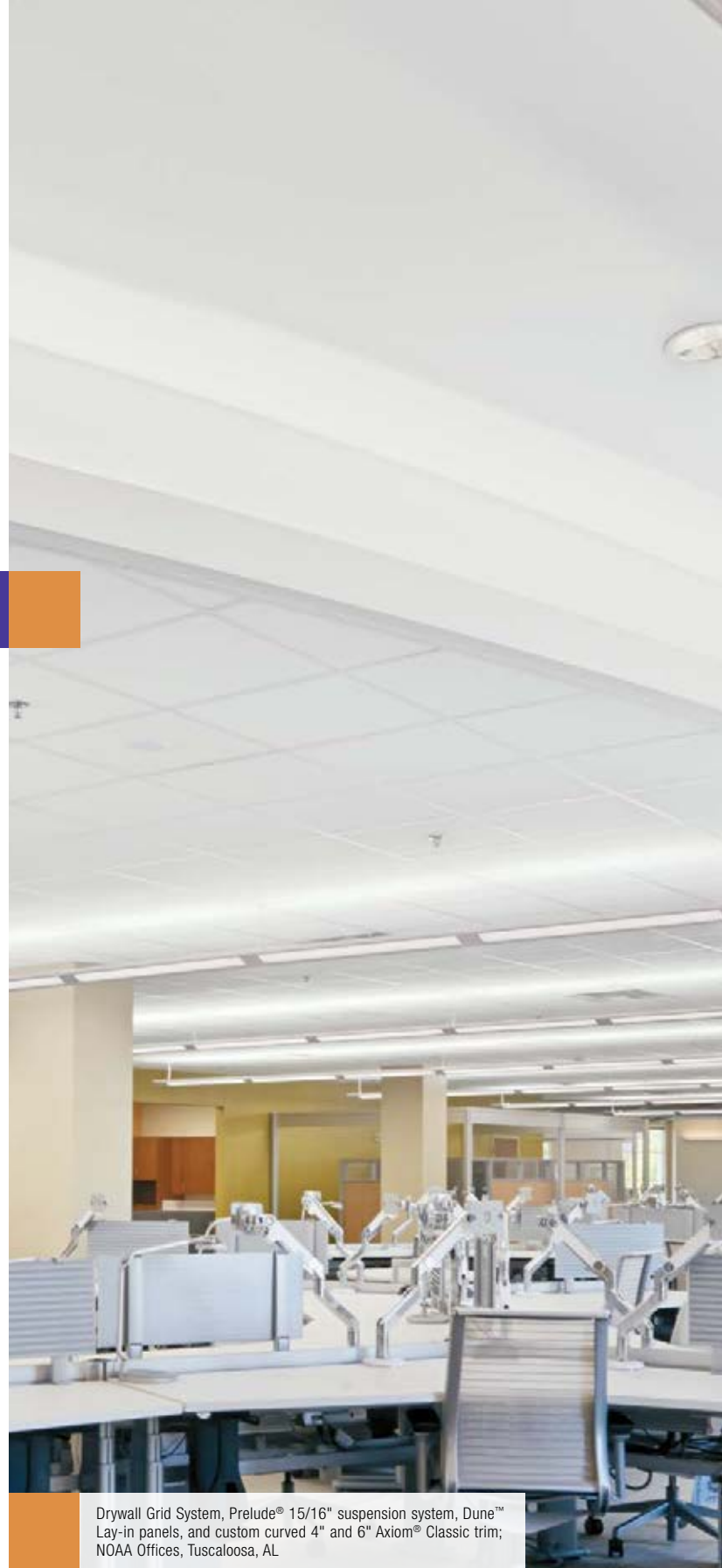

Drywall Grid System, Prelude® 15/16" suspension system, Dune™ Lay-in panels, and custom curved 4" and 6" Axiom® Classic trim; NOAA Offices, Tuscaloosa, AL



INSTALLATION SYSTEMS SPECIALISTS

Our industry exclusive Installation Systems Specialists are experts in ceiling construction and are always available to come to your job site for product installation consults, demonstrations, or to answer questions.

TECHLINESM

Our TechLine experts are committed to providing you the strongest technical support in the industry. Our dedicated team of experts has over 100 years of experience in commercial ceiling construction.

Call: 1 877-276-7876

Email: bpotechline@armstrong.com

Live Chat: armstrong.com/techline

CODE COMPLIANCE

Armstrong is a leader in seismic, fire, and acoustics testing, allowing us to provide you with the most comprehensive offering of code compliant ceiling solutions for every project requirement. Consult your Armstrong representative or call TechLine at 1 877 ARMSTRONG for more information.

innovative products

Standard pre-engineered solutions designed to keep your project on time, on budget, and on the mark.



Drywall Grid System, Prelude® 15/16" suspension system, Dune™ Lay-in panels, and custom curved 4" and 6" Axiom® Classic trim; NOAA Offices, Tuscaloosa, AL

SOLUTIONS PORTFOLIO

DRYWALL GRID

- Drywall grid installs three times faster than traditional track and channel framing – reducing material and labor costs
- Simplify your curved drywall installations with pre-notched main beams to create the radius you need
- New Impact Isolation Clip (IIC) helps ensure your ceiling meets IBC code for impact insulation class
- Learn more at armstrong.com/drywall

AXIOM® PERIMETER POCKETS

- 12 times faster to install than traditionally framed shade pockets
- No framing – suspend with a single wire or 2-1/2" stud on 4' centers
- Compatible with a wide range of shades
- Learn more at armstrong.com/axiombuildingperimeters

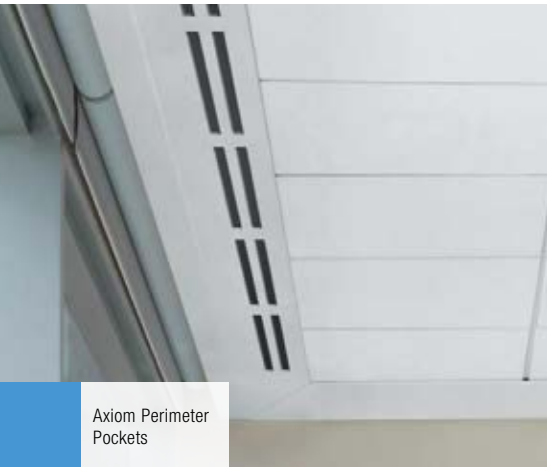

Axiom Perimeter Pockets

FASTSIZE™ PANELS AND GRID

- Three-week lead times and one carton minimums shipped fast
- Factory finished panels and suspension systems in just the right sizes for your project
- Reduces punch list items and speeds installation
- Learn more at armstrong.com/fastsize



FastSize Panels and Grid

ACOUSTICAL-TO-DRYWALL TRANSITION MOLDINGS

- Install twice as fast as traditional methods
- Eight transition profiles for popular acoustical-to-drywall transition situations
- Compatible with all types of Armstrong acoustical and drywall suspension systems
- Learn more at armstrong.com/transitionmoldings



Acoustical-to-Drywall Transition Molding



Serpentina® Waves™ panels, Champagne Gold and Wolf (color achieved with lighting effects); Destiny USA Mall, Syracuse, NY

CLOUDS, CANOPIES & BLADES

- Standard suspension system, trim, and hanging components come pre-cut and ready to install
- Excellent acoustical performance
- Available in fiberglass, mineral fiber, MetalWorks™, and WoodWorks® panels
- Learn more at armstrong.com/cloudsandcanopies

LINEAR LIGHTING INTEGRATION

- Now continuous linear lighting is easy to incorporate into any ceiling design
- Use made-to-order factory finished panels and suspension systems for a perfect finished visual
- Learn more at armstrong.com/linearlighting



Ultima® Beveled Tegular 24" x 24" panels with Silhouette® XL® 9/16" suspension system with 1/4" reveal and 4" linear light fixture



WoodWorks® Concealed panels; Lyric Opera House, Kansas City, MO

SOLUTIONS PORTFOLIO

METALWORKS™ AND WOODWORKS® CEILING SYSTEMS

- Standard ceilings deliver and install faster than custom solutions
- Pre-engineered for easy installation and consistently accurate fit and finish
- Learn more at armstrong.com/metalworks and armstrong.com/woodworks

ULTIMA® AND OPTIMA® CREATE!™ CEILING PANELS

- Transfer custom artwork onto high performance acoustical ceiling panels
- Excellent sound absorption, anti-mold and mildew, and resistance to impact, scratching, water, and soil
- Create with your own artwork, choose from our designs, or specify solid colors
- Learn more at armstrong.com/create



Ultima® Create!™ Vector® panels with Prelude® XL® 15/16" suspension system; Springmill Learning Center, Mansfield, OH

DATA CENTER CEILING SYSTEMS

- Complete data center ceiling system includes suspension system and panels for almost any application
- Reduce overall airspace volume for lower cooling loads
- Gasketed suspension systems reduce the risk of airborne particulates
- Learn more at armstrong.com/datazone

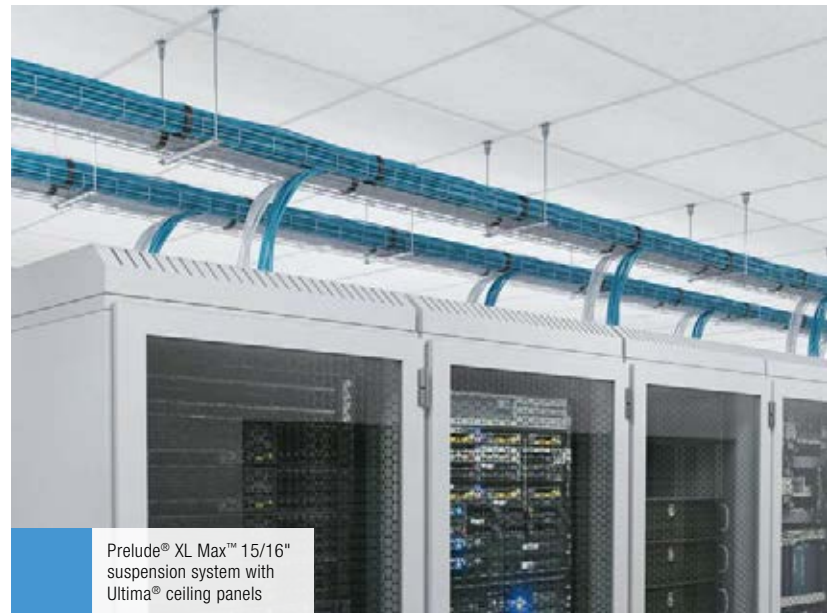

Prelude® XL Max™ 15/16" suspension system with Ultima® ceiling panels



Calla™ panels in White with Suprafine® 9/16" suspension system; PepsiCo, Purchase, NY

CALLA™ CEILING PANELS

- Smooth, drywall-look ceiling panels
- Excellent combination of NRC (0.85) and CAC (32) for superior acoustical performance
- Manufactured with up to 76% recycled content
- Compatible with TechZone® Ceiling Systems
- Learn more at armstrong.com/calla

SUSTAINABILITY



being green

CEILING RECYCLING PROGRAM

- The first Ceiling Recycling Program in the industry
- More than 77,500 tons of construction waste diverted from landfills since 1999
- Old panels get recycled into higher post-consumer Ceiling-2-Ceiling™ products
- Learn more at armstrong.com/recycling



SoundScapes® Shapes concave and convex panels in White and Moss, 4" Axiom® Classic curved trim, Dune™ Lay-in panels, Suprafine® XL® 9/16" suspension system; Zionsville High School, Zionsville, IN



WoodWorks® Vector® Custom Ceiling System perforated/unperforated in Vertical Grain Douglas Fir; Arizona State University, Memorial Union, Tempe, AZ

CONTRIBUTIONS TO LEED® V4

- Armstrong Ceiling & Wall Systems offer the broadest range of sustainable choices
- Choose from mineral fiber, fiberglass, MetalWorks™, and WoodWorks® panels
- Contribute to LEED v4 credits in up to nine categories
- Learn more at armstrong.com/sustainable



Optima® Vector® 48" x 48" panels; University of Tampa, Tampa, FL

CERTIFIED SUSTAINABLE WOODWORKS® PANELS

- FSC® chain of custody (CoC) certified wood panels
- Made with 100% biobased content
- Certified by the USDA BioPreferred® Products program
- Learn more at armstrong.com/woodworks

CEILING-2-CEILING™ PRODUCTS

- The highest level of recycled content from a closed-loop, post-consumer process
- The only ceiling panels made from reclaimed ceilings
- Deliver a higher MRc4 LEED post-consumer percentage than comparable products
- Available in Ultima®, Dune™, and Cirrus®
- Learn more at armstrong.com/c2c

take the next step

Product data pages, installation instructions, and warranty details

Order samples

Download CAD/Revit drawings

Download specifications

Name of your Armstrong Representative

Customer Service 1 877 Armstrong (276-7876)

TechLine – Technical information, detail drawings, CAD design assistance, installation information, other technical services – 8 a.m. to 5:30 p.m. EST, Monday through Friday. Phone 1-877-276-7876 option 1 or email: techline@armstrong.com

Stay connected:



facebook.com/armstronginstallationsystems



twitter.com/armstrongcis



youtube.com/armstrongceilings

Cover Photo: MetalWorks™ Torsion Spring panels, Custom red color
Berklee College of Music Student Center, Boston, MA

LEED® is a registered trademark of the U.S. Green Building Council.
All other trademarks used herein are the property of AWI Licensing Company and/or its affiliates
© 2015 AWI Licensing Company • Printed in the United States of America

TechLineSM / 1 877 ARMSTRONG
1 877 276 7876
armstrong.com/commceilings

Inspiring Great Spaces™

Armstrong[®]
CEILING & WALL SYSTEMS