

Design
Guide

METALWORKS™
Blades – Classics

Armstrong®
World Industries

Create a memorable VISUAL

The durability of metal with design options using standard or custom panel lengths and finishes, limited only by imagination.

- ▶ Acoustics and aesthetics for hundreds of creative layouts
- ▶ Blades panel lengths range from 22-1/2" to 96"
- ▶ Standard blade sizes in multiple lengths with 4" depths and 1" widths or 6" depths with 1" or 2" widths
-  ▶ Over 20 standard wood-look finishes
- ▶ Select MetalWorks™ Blades – Classics panels are part of the Sustain™ portfolio (unperforated panels only)
- ▶ Installs on standard Prelude® XL® 15/16" or 360° painted suspension system

MetalWorks Blades – Classics ▶
2" x 6" panels in Effects™ Cherry

More Options = More Designs





▲ MetalWorks™ Blades – Classics panels in 46-1/2" and 96-1/2" lengths in Sequels™ Montauk Driftwood



Classic Doesn't Mean ORDINARY

Express a new narrative with MetalWorks™ Blades – Classics linear panels. From divergent drama to striated stories; from sunflowers to sunbursts, create a look to visually tell your tale with the classic product that will spark your imagination. Also, add wood looks using Effects™ or Sequels™ wood-look finishes. Turn the page for layouts that will inspire your linear prose.

METALWORKS™ Blades – Classics

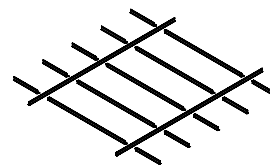

1' x 4' Grid Layouts

Divergent Pattern

SHOWN WITH:

6 × 1 × 22-1/2" panels

6 × 1 × 46-1/2" panels

6 × 1 × 96" panels

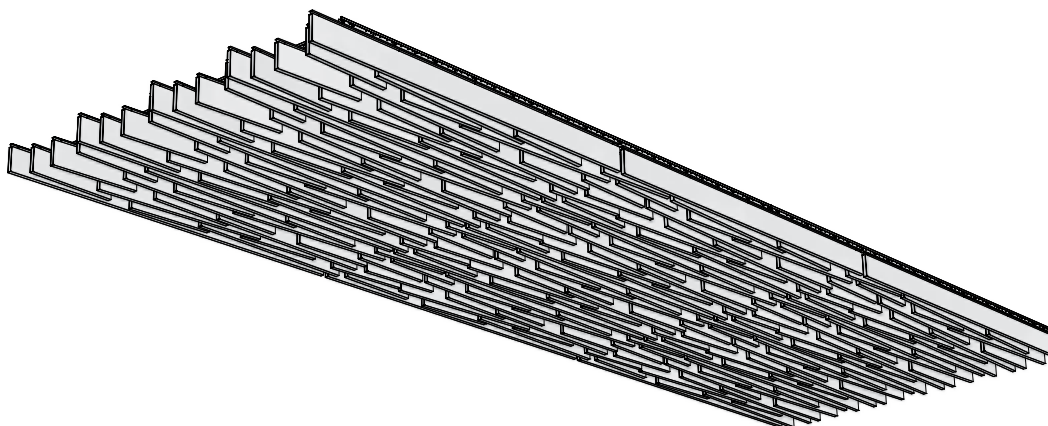
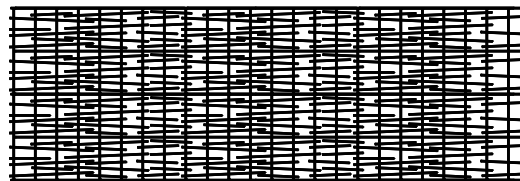

[View Ceiling Plan Drawing >](#)

Striated Pattern

SHOWN WITH:

22-1/2", 46-1/2", and 96" length panels in varying widths and depths of 1" x 4", 1" x 6" and 2" x 6"

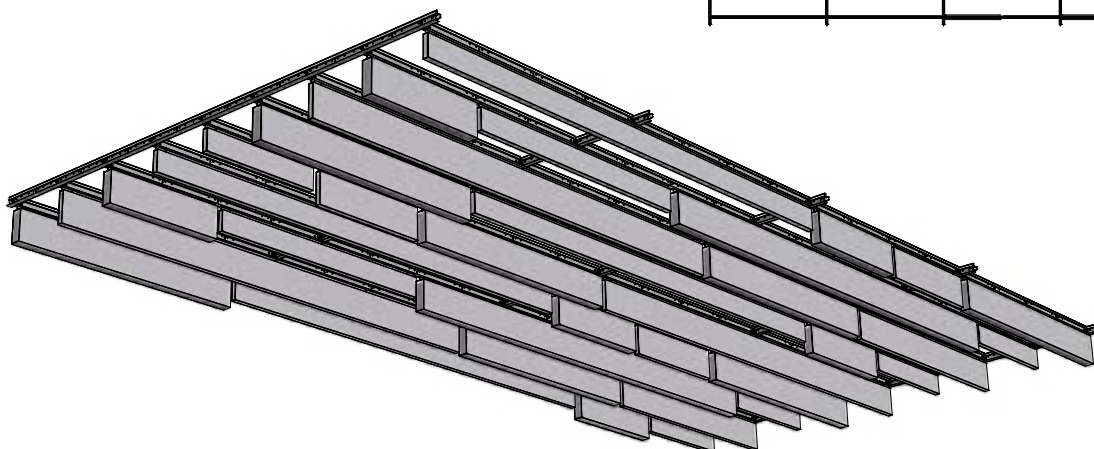
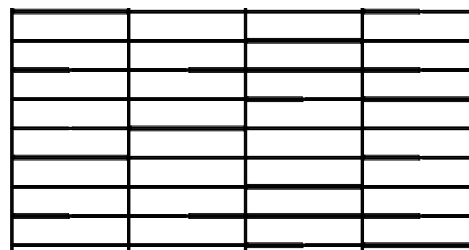

[View Ceiling Plan Drawing >](#)

METALWORKS™ Blades – Classics

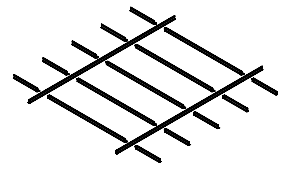

1' x 4' Grid Layouts

Sunflower Pattern

SHOWN WITH:

4 × 1 × 22-1/2" panels

4 × 1 × 46-1/2" panels

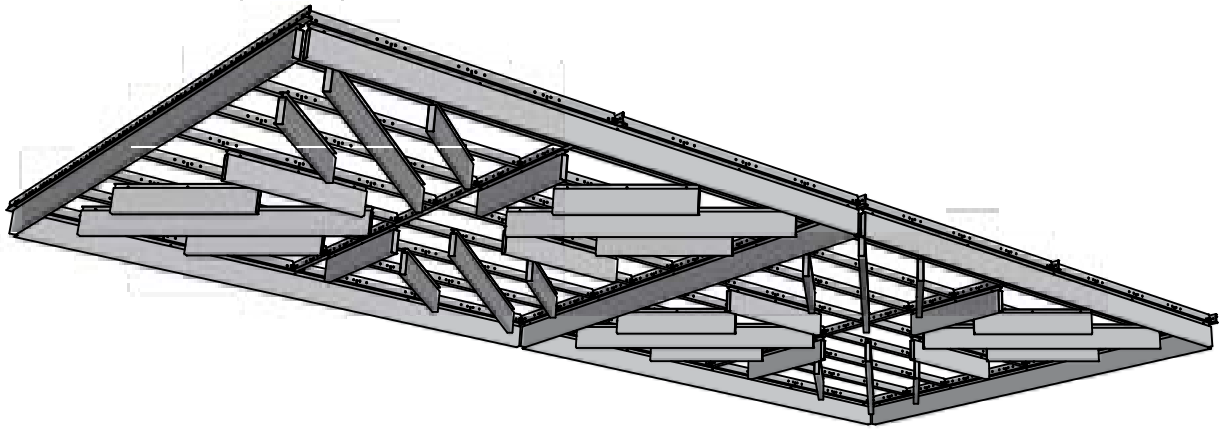
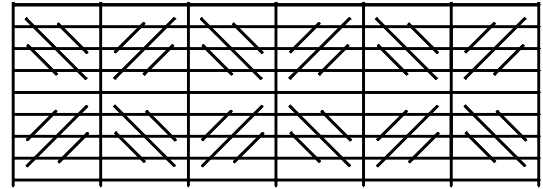

[View Ceiling Plan Drawing >](#)

Arrows Pattern

SHOWN WITH:

4 × 1 × 22-1/2" panels

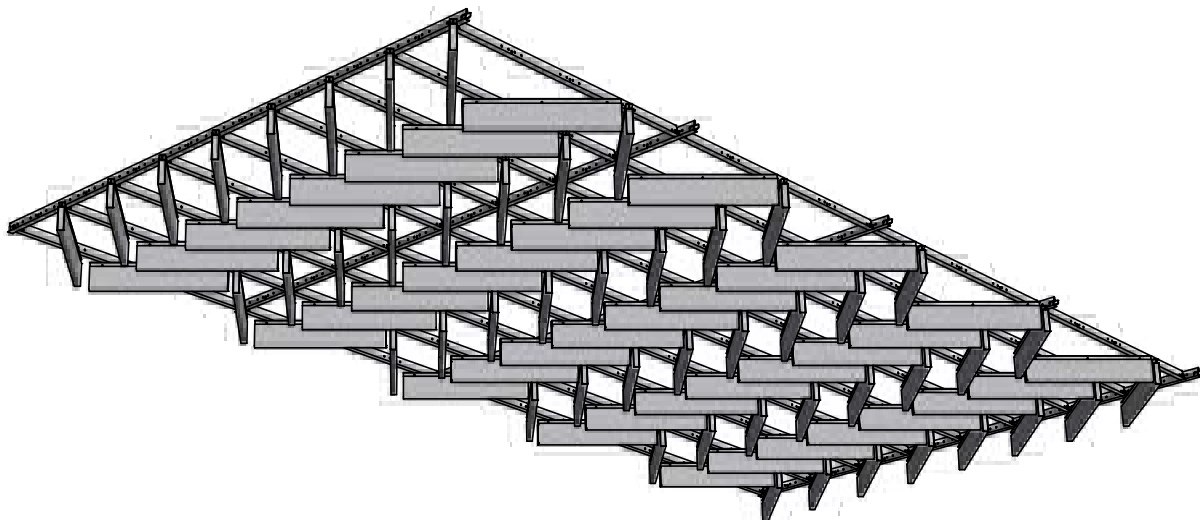
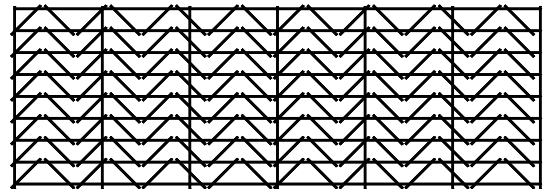

[View Ceiling Plan Drawing >](#)

METALWORKS™ Blades – Classics

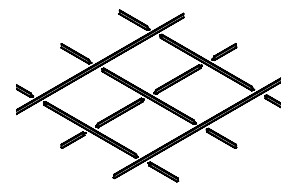

2' x 2' Layouts

Open Cell Pattern

SHOWN WITH:
6 × 1 × 22-1/2" panels

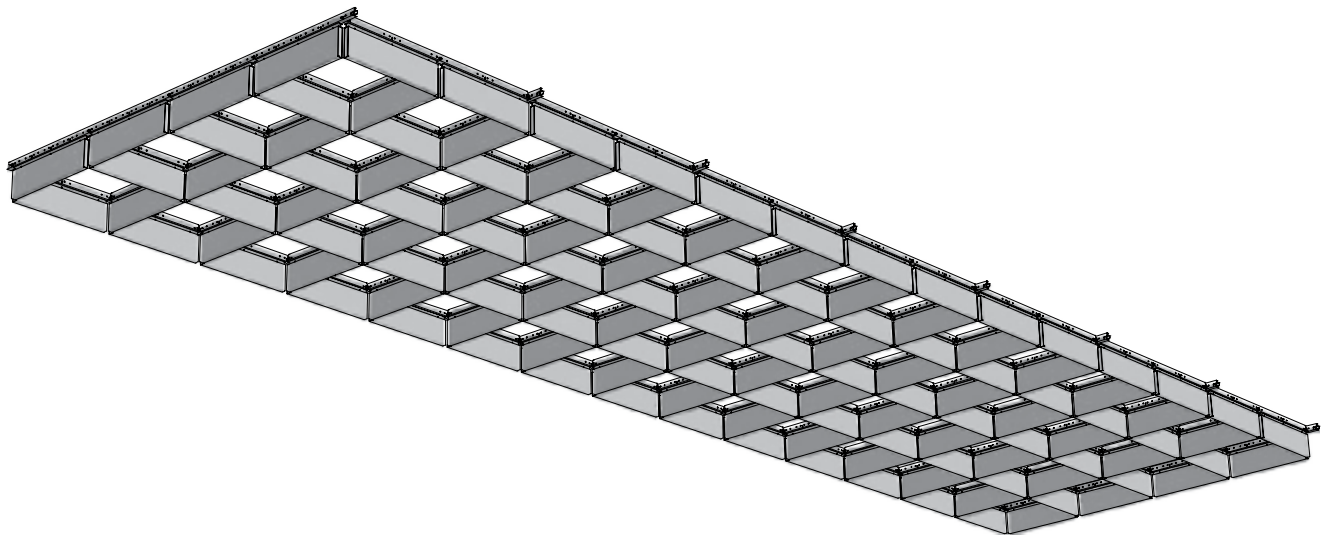
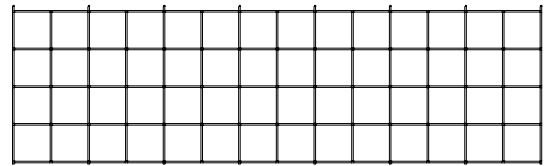

[View Ceiling Plan Drawing >](#)

90 Degree Pattern

SHOWN WITH:
6 × 1 × 96" panels

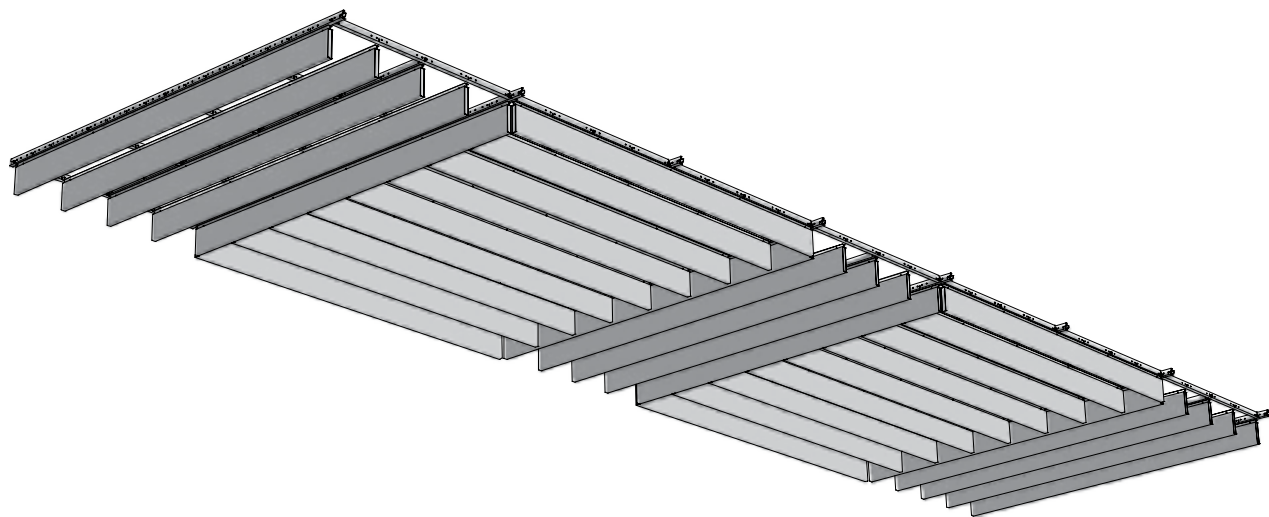
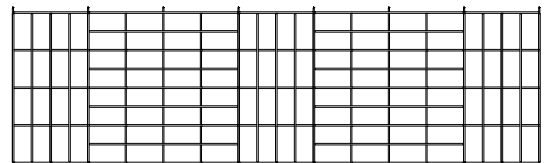

[View Ceiling Plan Drawing >](#)

METALWORKS™ Blades – Classics

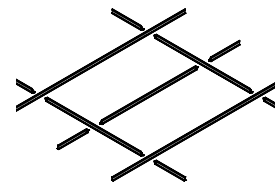

2' x 4' Layouts

Diagonal Layered 45 Degree Pattern

SHOWN WITH:
4 x 1 x 46-1/2" panels

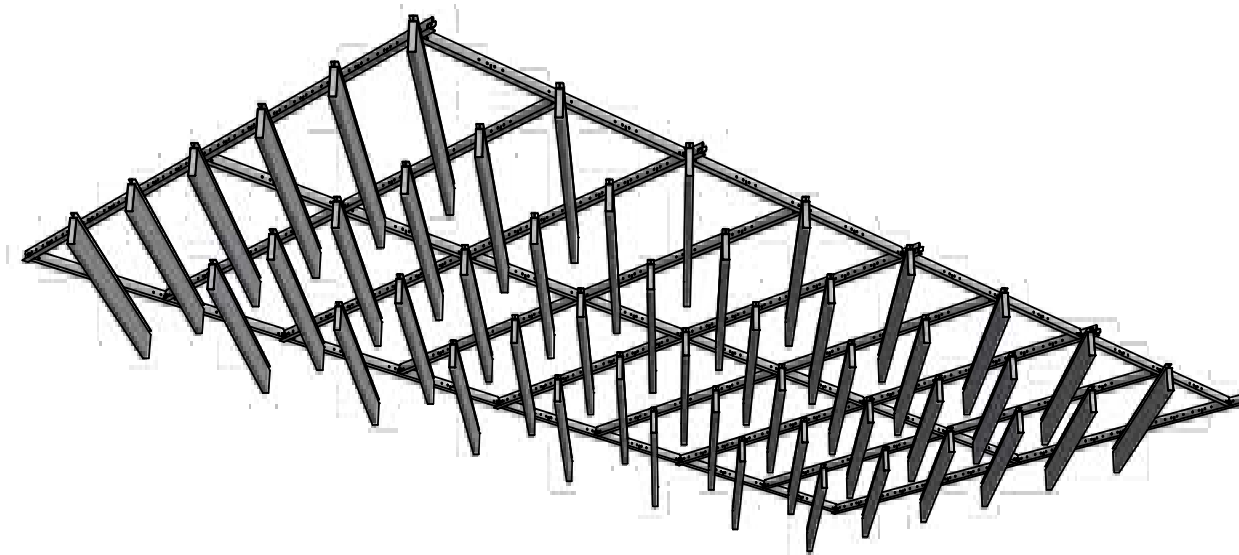
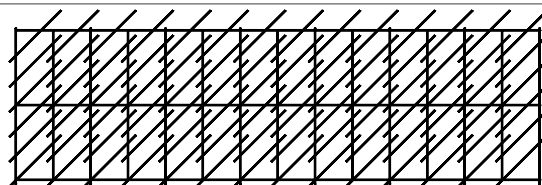

[View Ceiling Plan Drawing >](#)

Herringbone Pattern

SHOWN WITH:
6 x 1 x 46-1/2" panels

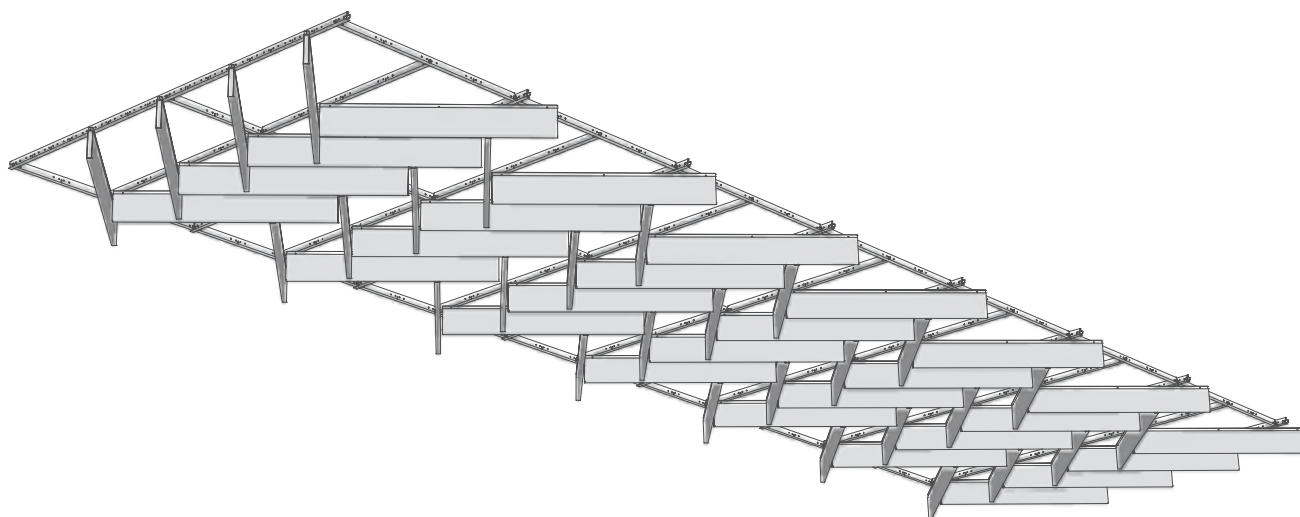
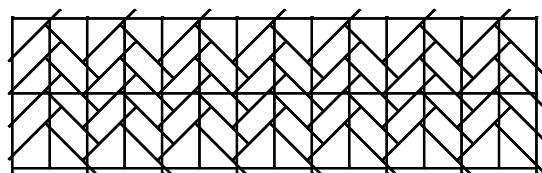

[View Ceiling Plan Drawing >](#)

METALWORKS™ Blades – Classics

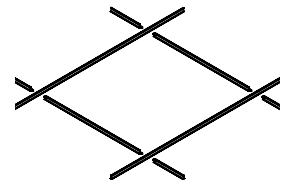

4' x 4' Layouts

8 Ft Diagonal 10 Degree Pattern

SHOWN WITH:

6 × 2 × 96" panels

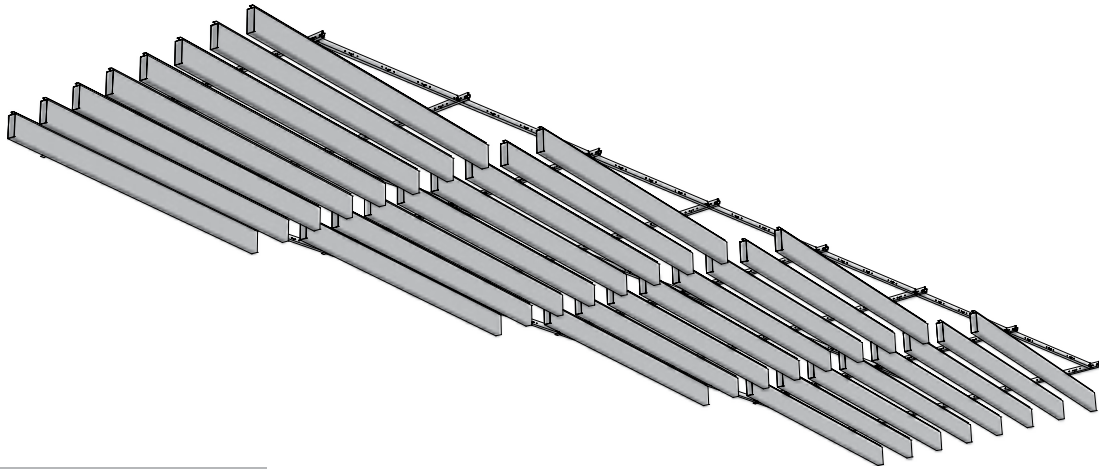
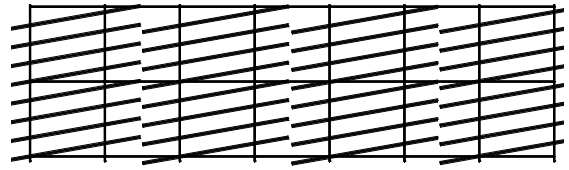

[View Ceiling Plan Drawing >](#)

8 Ft Staggered Pattern

SHOWN WITH:

6 × 2 × 96" panels

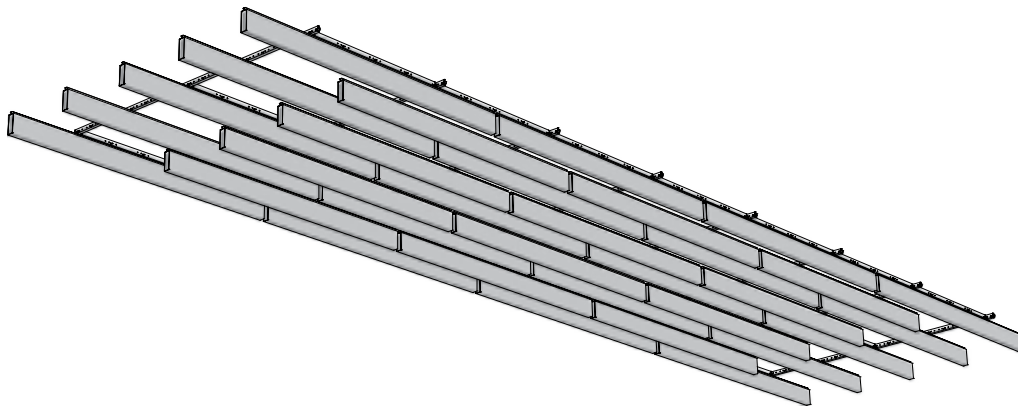
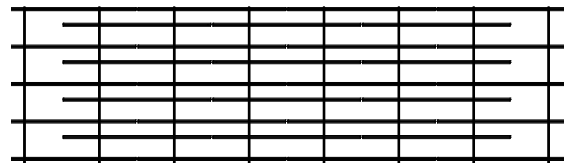

[View Ceiling Plan Drawing >](#)

METALWORKS™ Blades – Classics

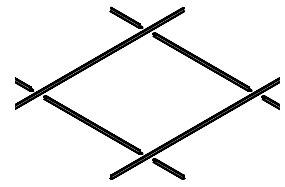

4' x 4' Layouts

8 Ft Wave 5 Degree Pattern

SHOWN WITH:

4 × 1 × 96" panels

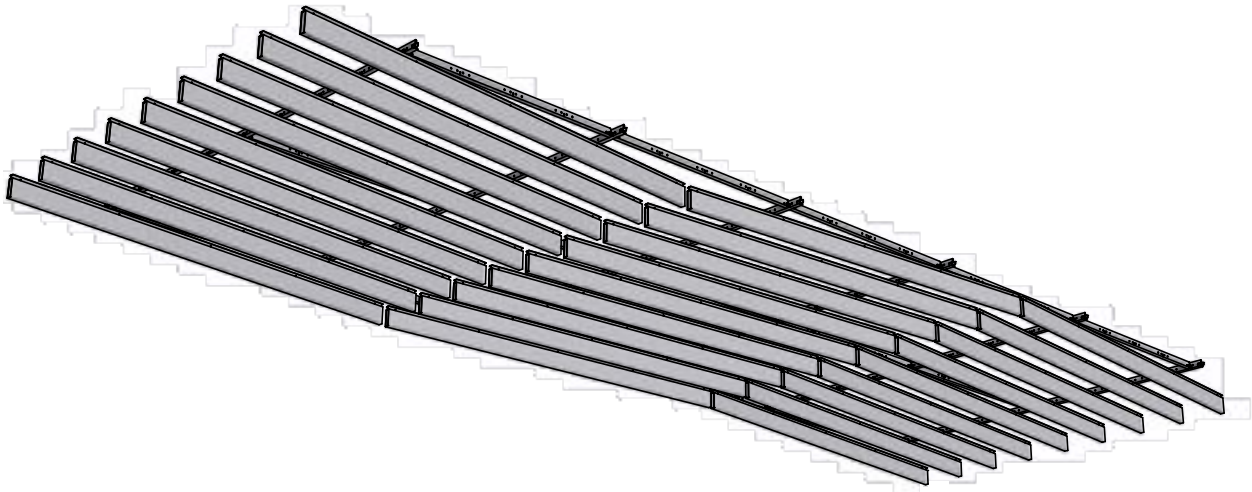
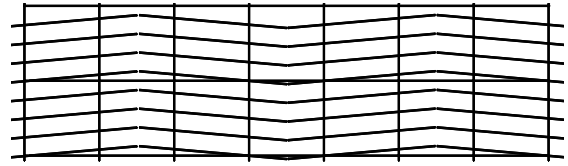

[View Ceiling Plan Drawing >](#)

8 Ft Wave Cross 10 Degree Pattern

SHOWN WITH:

6 × 1 × 96" panels

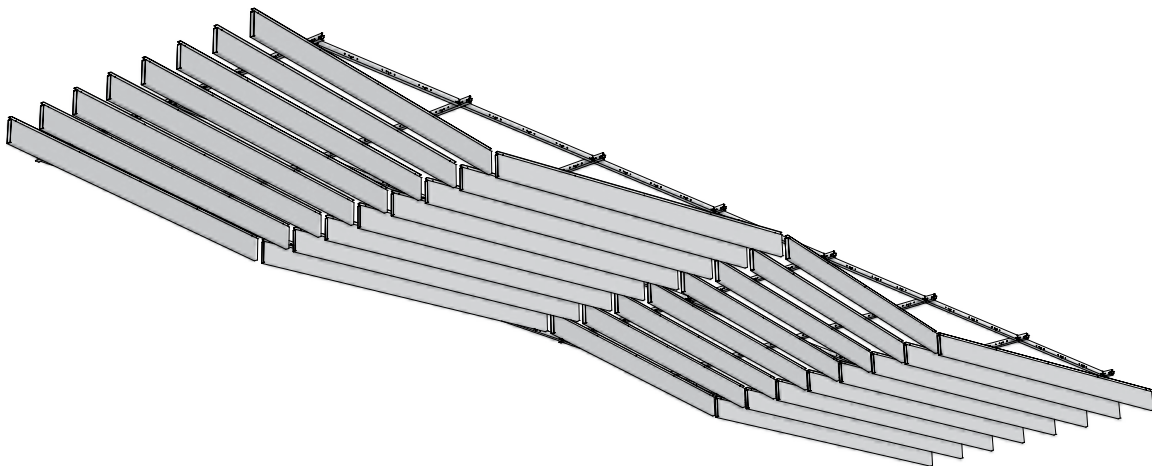
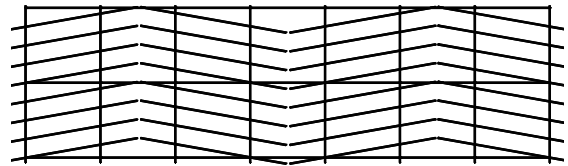

[View Ceiling Plan Drawing >](#)

METALWORKS™ Blades – Classics

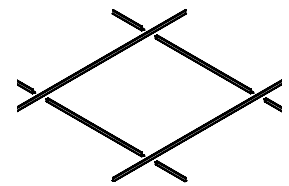

4' x 4' Layouts

8 Ft Cross 5 Degree Pattern

SHOWN WITH:

6 × 2 × 96" panels

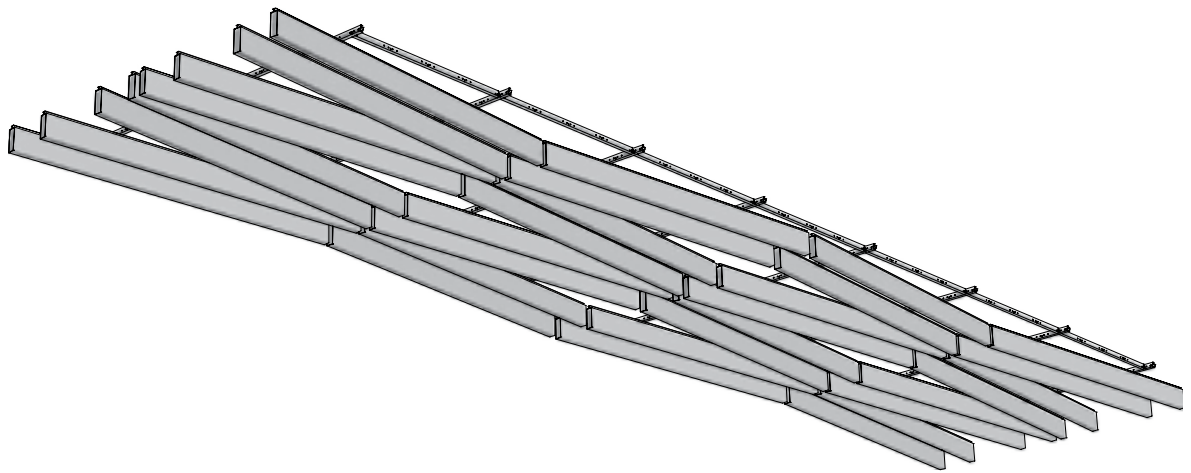
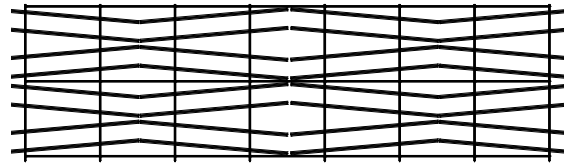

[View Ceiling Plan Drawing >](#)

8 Ft Triple Cross 5 Degree Pattern

SHOWN WITH:

4 × 1 × 96" panels

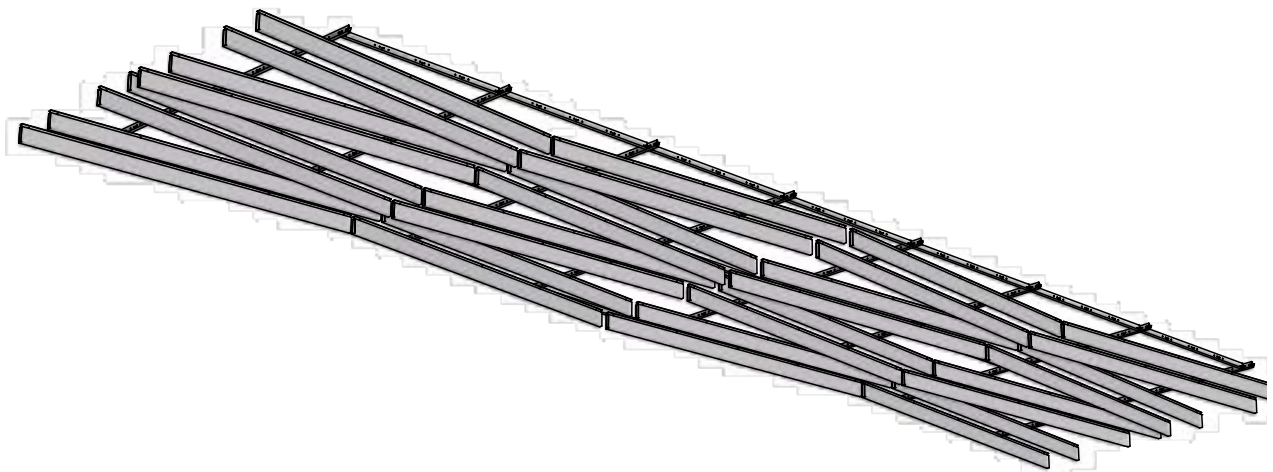
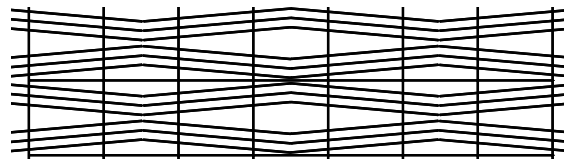

[View Ceiling Plan Drawing >](#)

METALWORKS™ Blades – Classics

Variable Module: Grid Layout Based on Your Personal Design

Sunburst Pattern

SHOWN WITH:

6 × 1 × 22-1/2" panels

6 × 1 × 46-1/2" panels

6 × 1 × 96" panels

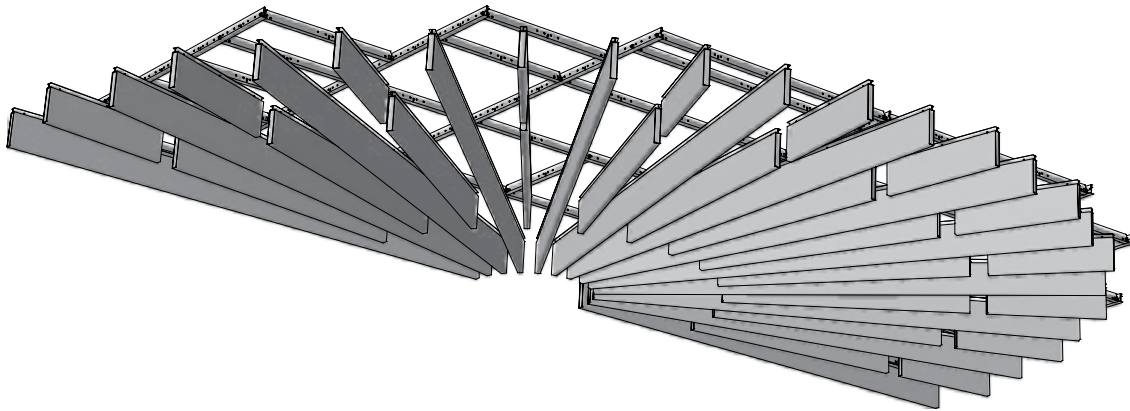
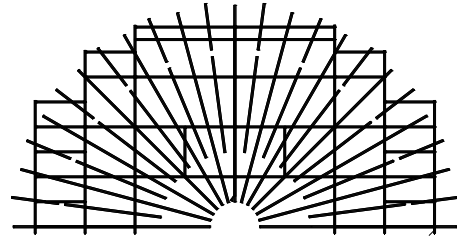

[View Ceiling Plan Drawing >](#)

METALWORKS™ Blades – Classics

Linear Panels with Acoustical Options
smooth texture



SUSTAIN™
High Performance
Sustainable
Ceiling Systems



FAST134
Select Items Ship Fast
armstrongceilings.com/fast134



CAD/Revit® drawings at:
armstrongceilings.com/cadrevit

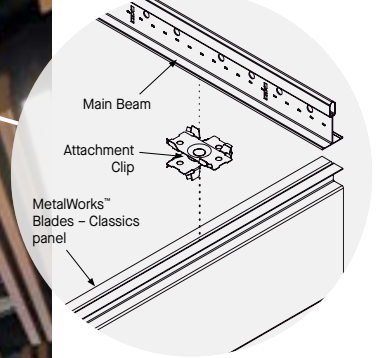

plus capabilities
to do more

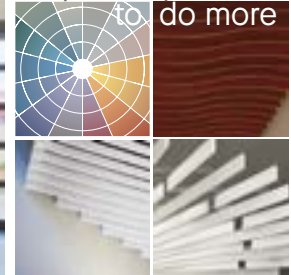

armstrongceilings.com/capabilities
See more photos at:
armstrongceilings.com/photogallery

MetalWorks Blades – Classics 2" x 6" panels in Effects Cherry

Durable metal vertical panels in multiple sizes with swivel attachment clips that allow for design flexibility.

KEY SELECTION ATTRIBUTES



- Four new Sequels™ pre-coat, wood-look finishes are part of the FAST134 program
- Now available in 17 Effects™ wood-look finishes
- Standard blade sizes in multiple lengths with either:
 - 4" depth and 1" width
 - 6" depth with 1" or 2" widths
- Premium blade sizes available:
 - Lengths up to 120"
 - Depths up to 10"
 - Widths 1" or 2"
- Available in 22-1/2", 46-1/2", 94-1/2", and 96" lengths for creative design layouts
- CleanAssure™ family of products – includes disinfectable panels, suspension systems, and trim
- Select products included in the FAST134 program – ready to ship in 4 weeks or less
- Blade panels available with either two factory-installed end caps, one end cap, or no end caps
- MetalWorks™ Blades – Classics panels are part of the Sustain™ portfolio (unperforated panels only)
- Create acoustical or non-acoustical upscale linear designs
- Fast, easy installation with standard Prelude® XL® 15/16" or 360° painted suspension systems

END CAP DETAILS in Sequels Cape May Cherry



1. Factory-applied End Cap
2. Field-cut End Cap

METALWORKS™ Blades – Classics

Linear Panels with Acoustical Options
smooth texture



LEED WELL LBC

80% RECYCLED CONTENT

- energy management
- construction waste mgmt
- regional materials
- design for flexibility
- EPD
- recyclable/extended producer resp.
- biobased materials
- recycled content
- sourcing of raw materials
- material ingredient reporting
- low emitting materials
- lighting quality
- acoustics

LOCATION DEPENDENT



MetalWorks™ Blades - Classics in Sequels Cape May Cherry



STANDARD COLORS & FINISHES

Due to printing limitations, shade may vary from actual product.

Painted

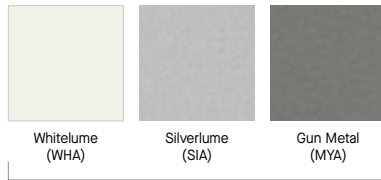

These colors are part of the Sustain™ portfolio (M1 – unperforated panels only)

Sequels™ Pre-coated Coil, Fast Lead Time

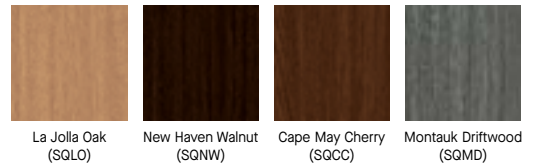

Effects™ Classic Dye-Sublimation



Effects™ Bold Dye-Sublimation



Effects™ Subtle Dye-Sublimation



CUSTOM COLORS & FINISHES

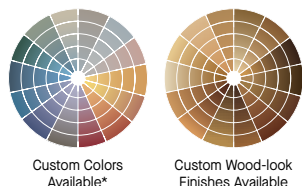

* Colors that are pre-qualified to meet Sustain portfolio requirements are available upon request. Other made-to-order colors must be evaluated if sustainability criteria is required. Lead time will increase. For more information, visit our website at armstrongceilings.com/metalworks or contact Architectural Specialties TechLine at 1 877 276-7876 for custom panel lengths. For premium requests contact ASQuote, ASQuote@armstrongceilings.com

PERFORATION OPTIONS (1:2 scale shown)

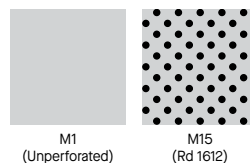

METALWORKS™ Blades – Classics

Linear Panels with Acoustical Options
smooth texture



LEED WELL LBC

80% RECYCLED CONTENT

- ✓ energy management
- ✓ construction waste mgmt
- ✓ regional materials
- ✓ design for flexibility
- ✓ EPD
- ✓ recyclable/extended producer resp.
- ✓ bio-based materials
- ✓ recycled content
- ✓ sourcing of raw materials
- ✓ material ingredient reporting
- ✓ low emitting materials
- ✓ lighting quality
- ✓ acoustics

LOCATION DEPENDENT

VISUAL SELECTION

Item No. ◆	Description/ Dimensions D x W x L (Inches) Custom Sizes Available	
8157D41 8157D61 8157D62	Vertical panel with caps on both ends 4 x 1 x 94-1/2" 6 x 1 x 94-1/2" 6 x 2 x 94-1/2"	
8156D41 8156D61 8156D62	Vertical panel with caps on both ends 4 x 1 x 46-1/2" 6 x 1 x 46-1/2" 6 x 2 x 46-1/2"	
8155D41 8155D61 8155D62	Vertical panel with caps on both ends 4 x 1 x 22-1/2" 6 x 1 x 22-1/2" 6 x 2 x 22-1/2"	
7202D41 7202D61 7202D62	Vertical panel with cap on one end 4 x 1 x 96" 6 x 1 x 96" 6 x 2 x 96"	
7203D41 7203D61 7203D62	Vertical panel with no end caps 4 x 1 x 96" 6 x 1 x 96" 6 x 2 x 96"	

PERFORMANCE

Sound Absorption† (Sabins/SF)	CleanAssure™ Disinfectable Panels		DURABILITY			
	Fog & Spray	Wipe	Wash	Scrub	Soil	
0.92	*	*	*	*	*	
0.92	*	*	*	*	*	
0.92	*	*	*	*	*	
0.92	*	*	*	*	*	
0.92	*	*	*	*	*	

Dots represent high level of performance

FAST
4 WEEKS
or Less

FAST134 program items ready to ship from manufacturer in 4 weeks or less. Up-to-date lead times and product options (sizes and colors) at armstrongceilings.com/fast134

◆ When specifying or ordering, include the appropriate perforation and color suffix with the item number (e.g., 8157D41 M 1 5 E X C H).
† With M15 perforation

DESIGN EXAMPLES Multiple lengths and swivel attachment clip allow for design freedom. Below are some design layout examples from our MetalWorks Blades design guide.

1' x 4' Grid Layouts

SunFlower Pattern
Shown with:
4 x 1 x 22-1/2" panels
4 x 1 x 46-1/2" panels

4' x 4' Grid Layouts

8 Ft Wave 5 Degree Pattern
Shown with:
4 x 1 x 96" panels

Striated Pattern
Shown with:
22-1/2", 46-1/2", and 96" length panels in varying widths and depths of 4" x 1", 6" x 1", and 6" x 2"

8 Ft Cross 5 Degree Pattern
Shown with:
6 x 2 x 96" panels

METALWORKS™ Blades – Classics

Linear Panels with Acoustical Options
smooth texture



80% RECYCLED CONTENT





LOCATION DEPENDENT

SUSPENSION SYSTEM & ACCESSORIES

	Item No. ♦	Description	Dimensions (Inches) Nominal L x W x H	Color	Pieces/Carton
Suspension Systems	7301_ _	Prelude® XL® 12' HD Main Beam	144 × 15/16 × 1-11/16"	White, Silver Grey, Gun Metal Grey*	20
	XL7341	Prelude XL 4' Cross Tee	48 × 15/16 × 1-11/16"	White, Silver Grey, Gun Metal Grey*	60
	XL8320	Prelude XL 2' Cross Tee	24 × 15/16 × 1-11/16"	White, Silver Grey, Gun Metal Grey*	60
	730136BL	Black 360 Prelude XL 12' HD Main Beam	144 × 15/16 × 1-11/16"	Black	20
	XL734036BL	Black 360 Prelude XL 4' Cross Tee	48 × 15/16 × 1-11/16"	Black	60
	XL732036BL	Black 360 Prelude XL 2' Cross Tee	24 × 15/16 × 1-11/16"	Black	60
Wall-to- Wall Installations	780036	12' Angle Molding	144 × 7/8 × 7/8"	Black, White*	30
	HD7801_ _	10' Angle Molding	120 × 7/8 × 7/8"	Silver Grey, Gun Metal Grey*	30
	BERC2	2" Beam End Retaining Clip	N/A	N/A	200
Floating Cloud Installations	AX6STR_ _ _ ♦	Axiom® Classic 6" Straight Trim	120 × 3/4 × 5-13/16"	White, Black, Silver Grey, Gun Metal Grey*	N/A
				Black is recommended for Sequels panel finishes	
	7239	Adjustable Trim Clip (ATC)	N/A	N/A	50
	5344_ _ _ _	4" Effects Wood Looks Trim	Nominal 120" Length	Effects Finishes	6
	5346_ _ _ _	6" Effects Wood Looks Trim	Nominal 120" Length	Effects Finishes	6

♦ Add the 2-digit color suffix to the item number when specifying or ordering (e.g. AX6STR 3 Q), add an extra digit "3" before the color suffix if paint is required inside and outside of trim (e.g. AX6STR 3 3 Q).
* Items with the same finish name will coordinate but may not be an exact color match.

ACCESSORIES

	Item No. ♦♦	Description	Color	Pcs/Ctn
	7204_ _	MetalWorks™ Blades – Classics Attachment Clip	Stainless Steel, Black Oxide	100
	7205D41 7205D61 7205D62	MetalWorks Blades – Classics 4" x 1" Alignment Device 6" x 1" Alignment Device 6" x 2" Alignment Device	N/A	24
	8158D41_ _ _ _ 8158D61_ _ _ _ 8158D62_ _ _ _	MetalWorks Blades – Classics 4" x 1" Field-Cut End Cap 6" x 1" Field-Cut End Cap 6" x 2" Field-Cut End Cap	Whitelume, Silverlume, Gun Metal, Sequels Finishes, Effects Finishes	10

♦♦ When specifying or ordering, include the color suffix with the item number (e.g., 8158D41 E X Q H).

SUSPENSION SYSTEMS

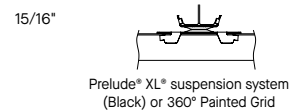

PHYSICAL DATA

Material
Aluminum – thickness 0.032"

Surface Finish
Painted: Factory-applied polyester paint
Sequels™: Pre-coated coil
Effects™: Powder-coated, dye-sublimation, post-production finish

Custom colors and finishes also available. Contact TechLine for custom color matching requests at 1 877 276-7876.

Fire Performance
Class A: Tested per ASTM E84. Flame Spread Index 25 or less. Smoke Developed Index 50 or less.
CAN/ULC S102 surface burning characteristics. Flame Spread Rating 25 or less. Smoke Developed Classification 50 or less.

Acoustical Options
Perforated panels are supplied with a black fiberglass fleece acoustic infill bag to absorb sound (varies by Blades panel length).

Design Support
For custom design assistance contact ProjectWorks® Design Services or visit armstrongceilings.com/projectworks

Seismic Restraint
MetalWorks Blades – Classics are approved for application in all seismic areas when installed per the seismic guidelines in the Armstrong Ceilings installation instructions.

FAST134 Program Considerations
Size of Job Matters: Big jobs, over 2500 SF or 50 pieces for shapes/vertical elements will have longer lead times.
Location Matters: Transit time not included. We are ready to ship in 1 week on FAST1 items. However, transit to the states west of Wyoming may add time.
Distributor Truck Schedule Matters: We rely on distribution to help move products around the country. When speed matters, work with your local distributor to ensure FAST134 service.
Stock vs Made-to-Order Matters: FAST3 & FAST4 items are made-to-order and will ship direct to distributor. FAST1 (stocked items) will go through distribution and depend on distributor truck schedules.

Design Considerations
When installed, panels hang either 4-7/8" or 6-7/8" below the face of the grid, depending on the depth of Blade. Panels can be supported by intermediate duty main beams or cross tees, with 2 attachment clips per panel. See MetalWorks Blades – Classics design guide online for additional design layouts.
MetalWorks Blades – Classics can be cut in the field only when using the Field-Cut End Cap. See installation instructions for details.

Cleaning and Disinfecting
Cleaning and CDC-approved disinfecting options available on armstrongceilings.com/cleaning

Warranty
Details at armstrongceilings.com/warranty

Weight
D41 panels: 0.50 lbs/LF
D61 panels: 0.61 lbs/LF
D62 panels: 0.68 lbs/LF



TAKE THE NEXT STEP

1 877 276-7876

Customer Service Representatives
7:45 a.m. to 5:00 p.m. EST
Monday through Friday

TechLine – Technical information,
detail drawings, CAD design assistance,
installation information, other technical
services – 8:00 a.m. to 5:30 p.m. EST,
Monday through Friday.
FAX 1 800 572 8324 or email:
techline@armstrongceilings.com

armstrongceilings.com/commercial

Latest product news

Standard and custom product information

Online catalog

CAD, Revit®, SketchUp® files

A Ceiling for Every Space® Visual Selection
Tool

Product literature and samples – express
service or regular delivery

Contacts – reps, where to buy, who will
install

ProjectWorks®

armstrongceilings.com/projectworks

The power of PROJECTWORKS® Design
and Pre-Construction Service

Mix and match different sizes, shapes,
colors, and materials to reinvent your
standard, specialty, or custom ceiling.

Visit our pattern gallery online to see
ideas for your next project.

armstrongceilings.com/patterngallery

Contact your local representative to
get a design started! Not sure who
your local rep is? Visit

armstrongceilings.com/findarep

Revit® is a registered trademark of Autodesk, Inc.; SketchUp® is a registered trademark of Trimble Inc.;
Declare® and Living Building Challenge® (LBC) are registered trademarks of the International Living
Future Institute®; LEED® is a registered trademark of the U.S. Green Building Council; WELL™ and WELL
Building Standard™ are trademarks of the International WELL Building Institute
All other trademarks used herein are the property of AWI Licensing LLC and/or its affiliates
© 2023 AWI Licensing LLC Printed in the United States of America

armstrongceilings.com/blades

On the cover: ►
MetalWorks™ Blades – Classics;
in Sequels™ Cape May Cherry

Armstrong®
World Industries