



# METAL WORKS™

Torsion Spring  
Ceiling Panels

# So Many CHOICES

From a monolithic visual, to blades, to mesh, MetalWorks™ Torsion Spring ceiling panels are available in a variety of styles and finishes. Ease of installation and increased accessibility make them the perfect choice for any project.

For the wood enthusiast, we offer three families of standard wood-look finishes, including our own factory-cut downlight panels for easy lighting integration. Standard and custom color options mean the sky's the limit.

MetalWorks Torsion Spring ▶  
panels in Sequels™ – New Haven  
Walnut wood-look finish





▲ MetalWorks™ Torsion Spring ceiling panels; Academy Tower Lobby, Los Angeles, CA

# Empower YOUR DESIGN

Choose from popular finishes and perforations, or custom colors and perforations, to empower your design.

- Select finishes are part of the FAST134 program – available to ship in 4 weeks or less
- Select finishes are part of the Sustain™ portfolio, meeting the most stringent industry sustainability standards
- CleanAssure™ family of products – includes disinfectable panels, suspension systems, and trim
- Monolithic visual with 100% downward accessibility
- NRC values up to 0.90 with fiberglass infill panels (select perforation patterns)



**SUSTAIN™**  
High Performance  
Sustainable  
Ceiling Systems



**24/7  
DEFEND™**  
Solutions for Healthier,  
Safer Spaces

PAINTED FINISHES

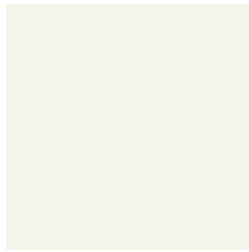

Whitelume\*  
(WHA)



Silverlume\*  
(SIA)



Gun Metal\*  
(MYA)



Custom Colors  
Available



Satin Anodized  
(SAA)



Lacquer Mill  
(LMA)



Brushalume  
(BAA)

STANDARD PERFORATION OPTIONS\*  
(1:1 scale shown)

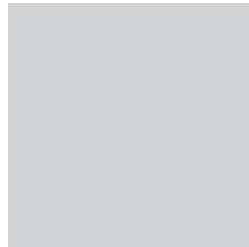

M1  
(Unperforated)

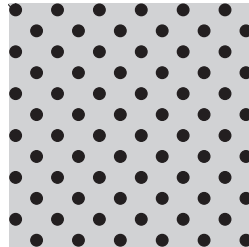

M15  
(Rd 1612)

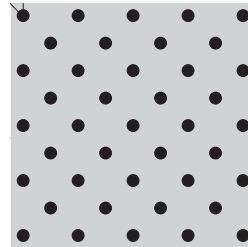

M16  
(Rd 1607)

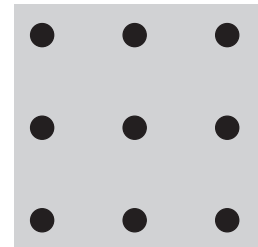

M14  
(Rg 3205)

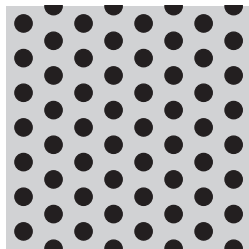

M17  
(Rv 3223)

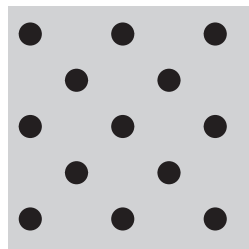

M18  
(Rd 3210)

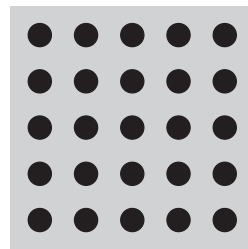

M19  
(Rg 3220)

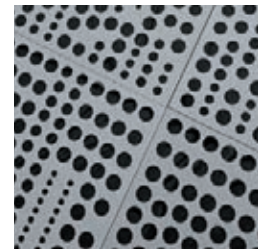

Custom Perforations  
Available



\* Part of the Sustain portfolio



▲ MetalWorks Torsion Spring ceiling panels in Sequels – Montauk Driftwood

new

# Sequels™ Pre-Coat WOOD LOOKS...FAST!

MetalWorks™ Sequels™ pre-coat finishes deliver wood-look visuals ... fast! Produced with high-definition, rotogravure printing technology, our newest family of wood looks is available as a standard finish on MetalWorks Torsion Spring, including factory-cut downlight panels.



- Part of the FAST134 program – available to ship in 4 weeks or less
- Factory-cut downlight panels and coordinating fixtures ensure that the intended design aesthetic is achieved every time
- Torsion Spring 24" x 24", M1 panels approved for exterior use
- Also available as standard on MetalWorks™ Clip-on



SEQUELS™  
PRE-COAT FINISHES



La Jolla Oak  
(SQLO)

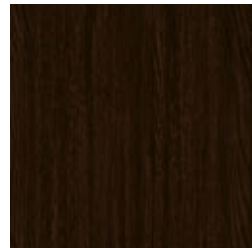

New Haven Walnut  
(SQNW)

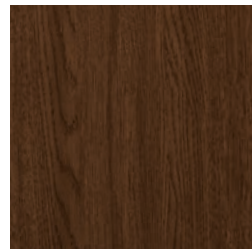

Cape May Cherry  
(SQCC)

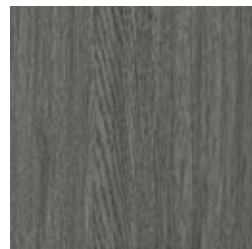

Montauk Driftwood  
(SQMD)



# UA Football Locker Room A LASTING IMPRESSION

## the challenge:

When designing the University of Alabama Football Locker Room at Bryant-Denny Stadium, the design team from Forty Nine Degrees wanted "to create a unique experience so that anyone walking through the space would know they were in the home of the Alabama Crimson Tide," explains Jesse Ranly, VP-Creative, Client Strategy at Forty Nine Degrees.

Situated at the end of the new team tunnel, where visitors are enveloped in audio-visual highlights of Alabama football history, the locker room is intended to be an extension of the sights and sounds of the tunnel.



## the solution:

The concept the Forty Nine Degrees design team developed called for a metal ceiling, perforated with the Alabama Script A logo and random trails of additional perforations. Diffused lighting from a series of LED light boxes behind the ceiling would accentuate the Script A logo and illuminate the space below.

To make the ceiling concept a reality, Forty Nine Degrees turned to the design professionals at Armstrong who realized the design intent with a custom perforated MetalWorks™ Torsion Spring Ceiling System.

While the original concept called for the perforations in all the ceiling panels to be unique, Armstrong found a way to reduce the cost by commonizing the perforation patterns in the panels that were not part of the Script A logo.

“Of the 194 panels that make up the ceiling, only 65 unique panels were required to make up the logo,” explains Armstrong Design Manager Dan Holdridge. “The rest of them are four different types of common panels. The perforation patterns in the common panels look random, but they aren’t.”

Concerned that the perforations would not allow enough light to penetrate the space, Forty Nine Degrees considered adding auxiliary light fixtures to the ceiling. “That would have really detracted from the design,” explains Holdridge. “So, we played around with the perforations in the logo to open them up a bit and let more light into the room.”

To demonstrate how much light output the larger perforations would provide, Armstrong created virtual mockups that simulated how bright the room would be with the design. “That really helped them to see how much light they would actually get and that it would be enough to light the space,” says Holdridge.

Pleased with the result, Ranly says the ceiling is a “show stopper” and credited the Armstrong team with making it possible. “Armstrong helped us transform our vision into reality,” he says. “Its team of specialists provided solutions that made our concept achievable both in design and function.”

▼ Custom MetalWorks Torsion Spring ceiling panels, University of Alabama Football Locker Room, Tuscaloosa, AL



# Natural Reflections SUSTAINABLE FINISHES

MetalWorks™ Natural Reflections laminate finishes bring warmth to a space with an embossed, gorgeous wood-look finish for an upscale visual.

- Part of the Sustain™ portfolio, meeting the most stringent industry sustainability compliance standards today
- Also available as standard on MetalWorks 3D



**SUSTAIN™**  
High Performance Sustainable  
Ceiling Systems

▼ Custom MetalWorks Torsion Spring ceiling and wall panels in Reflections – Rock Maple; Dover High School, Dover, DE





NATURAL REFLECTIONS  
SUSTAINABLE LAMINATE FINISHES



Honey Maple  
(LHM)

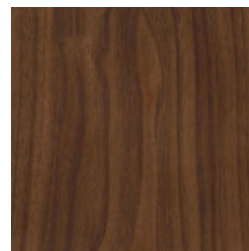

English Walnut  
(LEW)

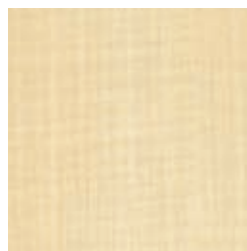

Cool Maple  
(LCM)



Honest Maple  
(LHS)

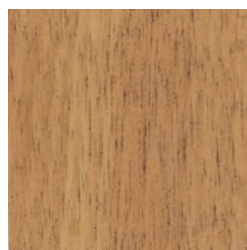

Spring Cherry  
(LSC)

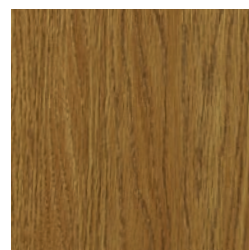

Beloved Oak  
(LB0)

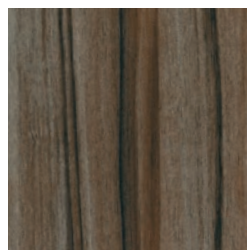

Midnight Forest  
(LMD)





▲ MetalWorks™ Torsion Spring panels in Effects – Maple

# Effects™ Wood Looks WARM & TIMELESS

Seventeen standard MetalWorks™ Effects™ wood-look finishes offer design options in bold, subtle, and classic wood grain looks.

- Interior and exterior applications
- Coordinating trim solutions for all Effects finishes
- Also available as standard on MetalWorks Clip-on and MetalWorks Linear – Classics, Synchro™, and Diverge™

EFFECTS CLASSICS  
POWDER-COAT FINISHES



Effects Oak  
(FXOK)



Effects Cherry  
(FXCH)



Effects Dark Cherry  
(FXDC)



Effects Walnut  
(FXWN)



Effects Walnut Espresso  
(FXWE)

EFFECTS BOLD  
POWDER-COAT FINISHES



Effects Sea Salt  
(FXSS, FXSS2)



Effects Poppy Seed  
(FXPS, FXPS2)



Effects Ginger  
(FXGR, FXGR2)



Effects Peppercorn  
(FXPC, FXPC2)



Effects Nutmeg  
(FXNM, FXNM2)



Effects Almond  
(FXAL, FXAL2)

EFFECTS SUBTLE  
POWDER-COAT FINISHES

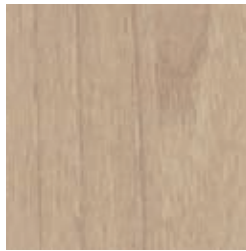

Effects Sesame  
(FXSE, FXSE2)

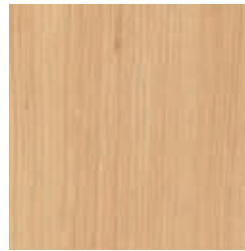

Effects Macadamia  
(FXMA, FXMA2)



Effects Cinnamon  
(FXCM, FXCM2)

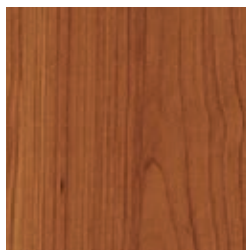

Effects Flax  
(FXFL, FXFL2)

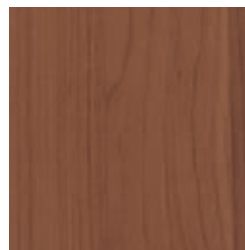

Effects Cocoa Bean  
(FXCB, FXCB2)



Effects Coriander  
(FXCO, FXCO2)

# METALWORKS™ Torsion Spring Interior and Exterior

smooth texture



**FAST134**  
Select Items Ship Fast  
[armstrongceilings.com/fast134](http://armstrongceilings.com/fast134)

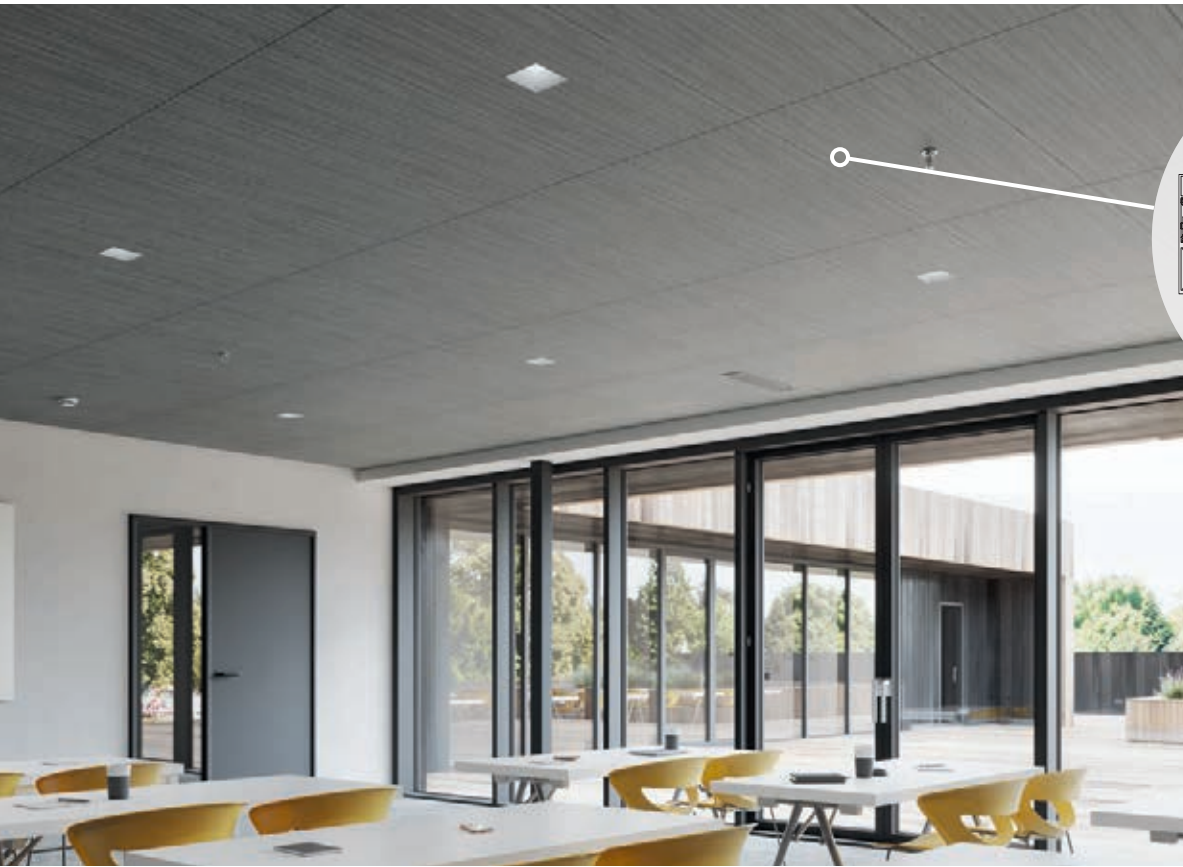

CAD/Revit® drawings at:  
[armstrongceilings.com/CAD-REVIT](http://armstrongceilings.com/CAD-REVIT)

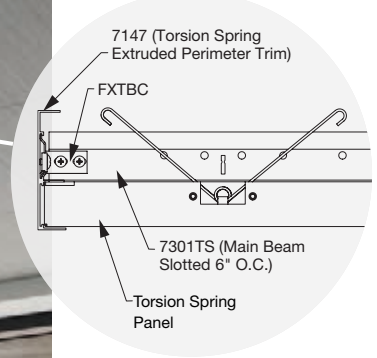

**CREATE!™**  
CUSTOM PERFORATIONS



[armstrongceilings.com/metalworkscreeate](http://armstrongceilings.com/metalworkscreeate)

▲ MetalWorks Torsion Spring panels in Sequels – Montauk Driftwood

MetalWorks™ Torsion Spring panels provide a monolithic visual with a unique hide-the-grid installation with 100% swing-down accessibility.

## KEY SELECTION ATTRIBUTES

- new** • Four new Sequels™ pre-coat, wood-look finishes are part of the FAST134 program, including downlight panels
- Seventeen standard Effects™ wood-look finishes offer on-trend design options in bold, subtle, and classic woodgrain looks
- new** • Natural Reflections laminate finishes provide superior wood-look visual with printed vinyl bonded to aluminum, now Class A and Canadian fire tested; visuals other than the ones shown are also available
- Precise factory-cut downlight panels are fit-and-finish certified to integrate with USAI® Lighting BeveLED® 2.2 and BeveLED® Mini trimless downlights
- new** • Sustainable Beyond Standard: Select standard and custom panels are part of the Sustain™ portfolio, and meet the most stringent industry sustainability compliance standards today
- CleanAssure™ family of products – includes disinfectable panels, suspension systems, and trim
- Select products included in the FAST134 program – ready to ship in 4 weeks or less
- Transform your images onto custom perforated MetalWorks™ Create!™ ceiling panels for a unique aesthetic plus acoustical performance
- Interior panels feature swing-down accessibility
- Exterior options available in 24 x 24 x 1-1/2" and 24 x 48 x 1-1/2" standard panel sizes
- NRC values up to 0.90 with fiberglass infill panels (select perforation patterns)
- Washable and impact-, scratch-, and soil-resistant

*Now, Lighting Integration Made Easy*



**DOWNLIGHTING:** MetalWorks Torsion Spring center-cut panel with coordinating USAI® Lighting trimless downlight fixture. Integration details at [armstrongceilings.com/downlighting](http://armstrongceilings.com/downlighting)

# METALWORKS™ Torsion Spring

## Interior and Exterior

smooth texture



**LEED WELL™ LBC**

**16% RECYCLED CONTENT**

Calculate sustainability with GreenGenie™  
armstrongceilings.com/greengenie

- energy management
- construction waste mgmt
- regional materials
- design for flexibility
- EPD
- recyclable/extended producer resp.
- biobased materials
- recycled content
- sourcing of raw materials
- material ingredient reporting
- low emitting materials
- lighting quality
- acoustics

LOCATION DEPENDENT

### STANDARD COLORS & FINISHES

Due to printing limitations, shade may vary from actual product.

#### Painted

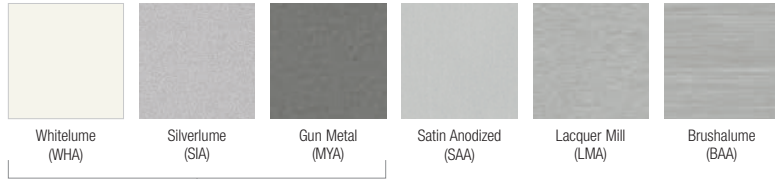

These colors are part of the Sustain™ portfolio

#### Sequels™ Pre-coat, Fast Lead Time

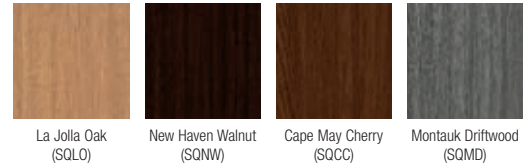

#### Natural Reflections (Interior Only)

Sustainable Laminate Finishes



These colors are part of the Sustain™ portfolio

#### Effects™ Classic Dye-Sublimation



#### Effects™ Bold Dye-Sublimation



#### Effects™ Subtle Dye-Sublimation



Sequels finishes for exterior: Available in M1 only on item 7225, and unavailable on item 7226.

Effects finishes are standard in 24" x 48" panels in M1 and M16.

Natural Reflections available for exterior applications as a custom option.

Contact AS Quote for custom size and perforation options.

### STANDARD PERFORATION OPTIONS

(1:2 scale shown)

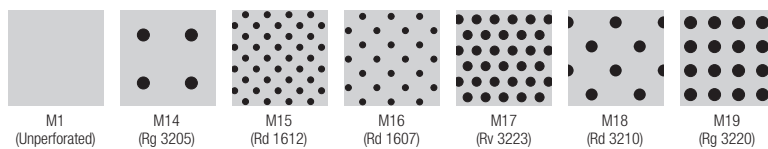

### CUSTOM COLORS & FINISHES

Due to printing limitations, shade may vary from actual product.

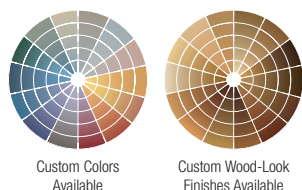

For custom options contact ASQuote,  
ASQuote@armstrongceilings.com

### PERFORATION OPTIONS



# METALWORKS™ Torsion Spring Interior and Exterior

smooth texture



**LEED WELL™ LBC**

**16% RECYCLED CONTENT**

Calculate sustainability with GreenGenie™ [armstrongceilings.com/greengenie](http://armstrongceilings.com/greengenie)

- energy management
- construction waste mgmt
- regional materials
- design for flexibility
- EPD
- recyclable/extended producer resp.
- biosourced materials
- recycled content
- sourcing of raw materials
- material ingredient reporting
- low emitting materials
- lighting quality
- acoustics

LOCATION DEPENDENT

**VISUAL SELECTION** Contact [ASOrder@armstrongceilings.com](mailto:ASOrder@armstrongceilings.com) for custom options.

Item No. ♦	Dimensions (Inches) W x L x H	Custom Sizes Available
<b>METALWORKS™ Torsion Spring Interior Panels Square 15/16"</b>		
7209_-----	24 x 24 x 1-1/2"	
7210_-----	24 x 48 x 1-1/2"	
7211_-----	24 x 72 x 1-1/2"	
7212_-----	24 x 96 x 1-1/2"	
7213_-----	30 x 30 x 1-1/2"	
<b>Other Size Panels</b>	W: 6" – 24" L: Up to 96" in 6" increments	
	W: 30" – 48" L: Up to 48" in 6" increments (Aluminum will be 0.060" thick)	
<b>Exterior Panels Square 15/16"</b>		
7225_-----	24 x 24 x 1-1/2"	
7226_-----	24 x 48 x 1-1/2"	



**FAST134 program items ready to ship from manufacturer in 4 weeks or less.**  
Up-to-date lead times and product options (sizes and colors) at [armstrongceilings.com/fast134](http://armstrongceilings.com/fast134)

♦ When specifying or ordering, include the appropriate perforation and color suffix with the item number (e.g., 7209 **M 1 4 L M A**).  
\* Light reflectance is for unperforated Whitelume.

**PERFORMANCE** Dots represent high level of performance.

Fire Performance	Light Reflect*	Springs per Panel	CleanAssure™ Disinfectable Panels		
			Fog	Spray	Wipe
Class A	0.75	4	•	•	•
Class A	0.75	4	•	•	•
Class A	0.75	6	•	•	•
Class A	0.75	6	•	•	•
Class A	0.75	4	•	•	•
Class A	0.75	Varies	•	•	•
Class A	0.75	Varies	•	•	•
Class A	0.75	4	•	•	•
Class A	0.75	4	•	•	•

**ACOUSTICAL INFORMATION**

Perforation		NRC with acoustical fleece	NRC with 1" fiberglass infill ††
<b>M1†</b>	Unperforated	N/A	N/A
<b>M14†</b>	Rg 3205	0.55	0.85
<b>M15</b>	Rd 1612	0.70	0.90
<b>M16</b>	Rd 1607	0.70	0.80
<b>M17†</b>	Rv 3223	0.75	0.90
<b>M18†</b>	Rc 3210	0.65	0.85
<b>M19†</b>	Rg 3220	0.75	0.90

† Available for exterior applications  
†† Maximum NRC achieved with acoustical infill (Item 8200T10 or 5823).

For infill panel information, visit [armstrongceilings.com/mwaccessories](http://armstrongceilings.com/mwaccessories)

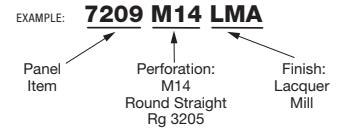

## PHYSICAL DATA

**Material**  
All panels, except 7226: Aluminum – 0.040"  
7226: Aluminum - 0.063"

**Surface Finish**  
Painted: Factory-applied polyester paint  
Effects: Powder-coated, dye-sublimation, post-production  
Sequels: Pre-coated  
Natural Reflections: PVC-free laminates  
Custom colors and finishes available.  
Custom Sequels finishes are available for orders 10,000 SF or larger.

**Fire Performance**  
Painted, Effects, Natural Reflections and Sequels finishes:  
Class A: ASTM E84. Flame Spread Index 25 or less. Smoke Developed Index 50 or less.  
Natural Reflections Finishes: CAN/ULC S102: Flame Spread Rating 30. Smoke Developed Classification 30.  
Painted aluminum finishes: CAN/ULC S102: Flame Spread Rating 25 or less. Smoke Developed Classification 50 or less.

**ASTM E1264 Classification**  
Painted, Effects, Natural Reflections and Sequels finishes:  
Unperforated: ASTM E1264 Type XX Pattern G Fire Class A  
Perforated - ASTM E1264 Type XX Pattern C Fire Class A

**Acoustical Options**  
Perforated panels are supplied with a black fiberglass fleece to absorb sound.

**Recycled Content**  
Up to 16%.

**Design Considerations**  
Anodized, Lacquer Mill and pre-coat finishes may vary in shade between production runs as well as over time. Sizes can be mixed and matched on non-perforated panels only.  
30" x 30" panels have a directional finish that is perpendicular to the main beams; all other panel sizes have a directional finish that is parallel to the main beams.  
MetalWorks steel and aluminum panels are made at different manufacturing facilities that use different paint systems. Because of this, similar colors, i.e., White and Whitelume, are not exact color matches. Please consider this when designing adjacent spaces with multiple MetalWorks products.  
On pre-coated finishes, clarity of image is best on flat surfaces. Pattern repeat may occur. Product is dye-lotted. Due to potential color variation, be certain to order sufficient initial quantities and attic stock.

**Wind Uplift Performance**  
24" x 24" and 24" x 48" panels noted for exterior flat applications tested for wind uplift Classes 30, 60, and 90. Specific installation instructions to meet these classes are available.

**Design Support**  
Project management assistance is available by calling TechLine customer support at 1 877 276-7876.

**Seismic Restraint**  
MetalWorks Torsion Spring panels have been engineered, tested, and approved for application in all seismic areas when installed per Armstrong Ceilings installation instructions.

**Cleaning and Disinfecting**  
Cleaning and CDC approved disinfecting options available on [armstrongceilings.com/cleaning](http://armstrongceilings.com/cleaning)

**FAST134 Program Considerations**  
Size of Job Matters: Big jobs, over 2500 SF or 50 pieces for shapes/vertical elements will have longer lead times.  
Location Matters: Transit time not included. We are ready to ship in one week on FAST1 items. However, transit to the states west of Wyoming may add time.  
Distributor Truck Schedule Matters: We rely on distribution to help move products around the country. When speed matters, work with your local distributor to ensure FAST134 service.  
Stock vs Made-to-Order Matters: FAST3 & FAST4 items are made-to-order and will ship direct to distributor. FAST1 (stocked items) will go through distribution and depend on distributor truck schedules.

**Warranty**  
One (1) year limited warranty.  
Details at [armstrongceilings.com/warranty](http://armstrongceilings.com/warranty)

**Weight**  
0.69 lbs/SF  
0.86 lbs/SF (Item 7226)



# METALWORKS™ Torsion Spring Interior and Exterior Installation Details



LEED WELL LBC

16% RECYCLED CONTENT

- energy management
- construction waste mgmt
- regional materials
- design for flexibility
- EPD
- recyclable/extended producer resp.
- biobased materials
- recycled content
- sourcing of raw materials
- material ingredient reporting
- low emitting materials
- lighting quality
- acoustics

Calculate sustainability with GreenGenie™  
armstrongceilings.com/greengenie

LOCATION DEPENDENT

## HOW TO INSTALL PANELS

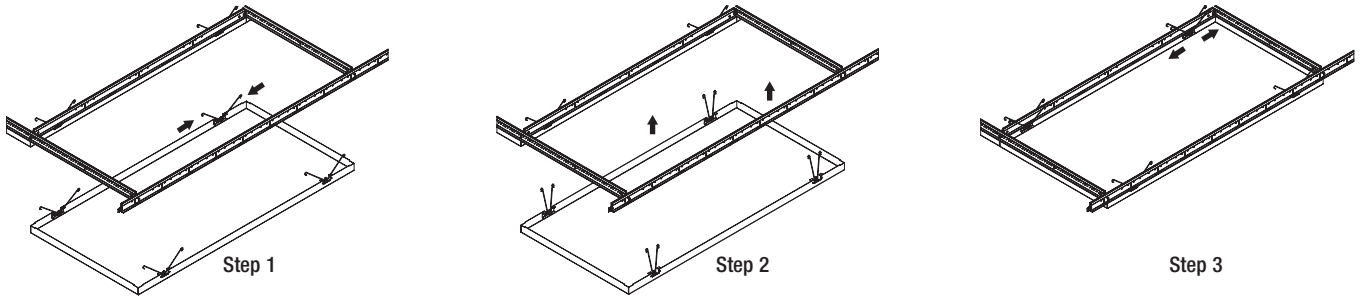

## INTERIOR INSTALLATION DETAILS For exterior details, consult the MetalWorks™ Exterior Torsion Spring installation instructions, BPLA-297922, on our website.

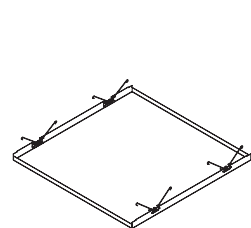
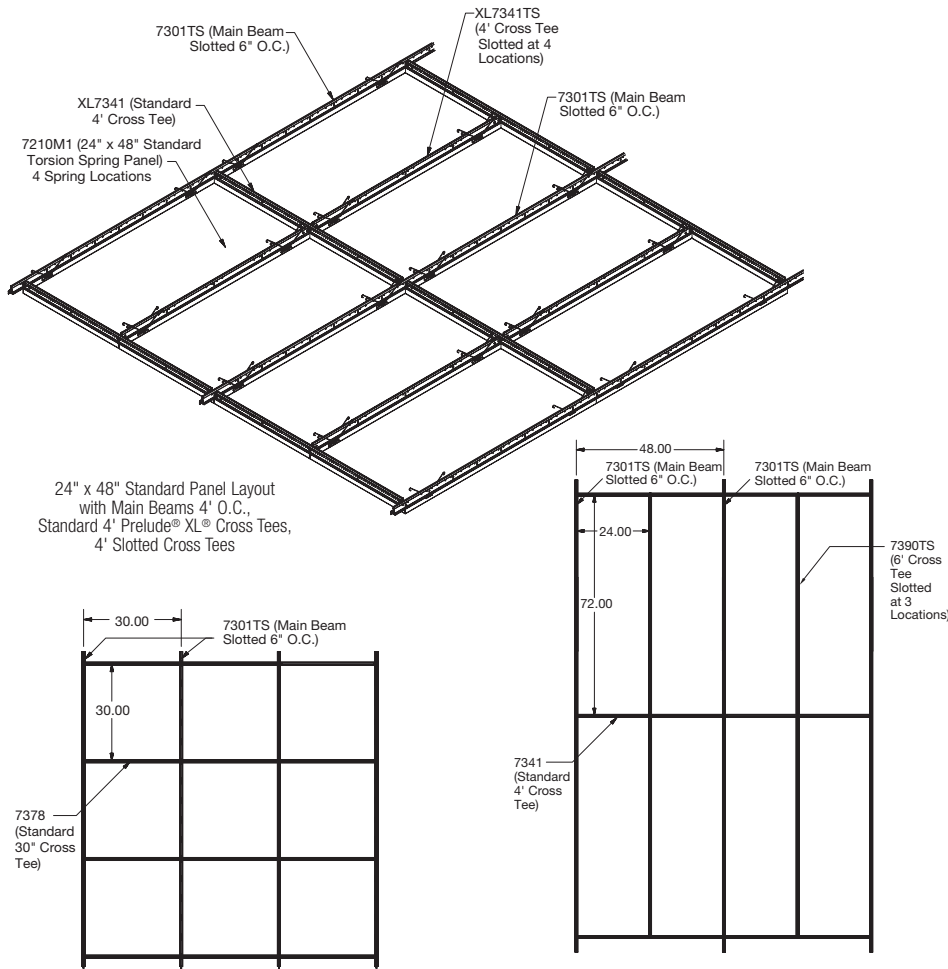

Suspension System Layout for 30" x 30" Panels

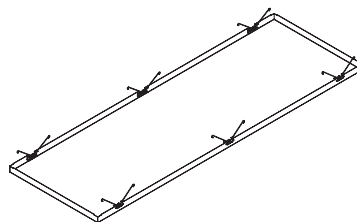

Suspension System Layout for 24" x 72" Panels

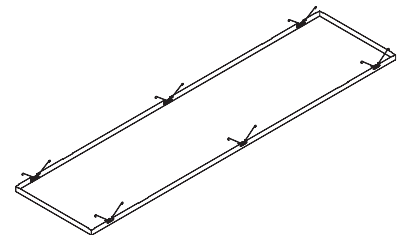

Suspension System Layout for 24" x 96" Panels

# METALWORKS™ Torsion Spring Interior and Exterior

## Perimeter Details



**LEED WELL™ LBC**

**16% RECYCLED CONTENT**

Calculate sustainability with GreenGenie™  
armstrongceilings.com/greengenie

energy management	construction waste mgmt	regional materials	design for flexibility	EPD	recyclable/extended producer resp.	bio-based materials	recycled content	sourcing of raw materials	material ingredient reporting	low emitting materials	lighting quality	acoustics
✓	✓	✓	✓	✓	✓	✓	✓	✓	✓	✓	✓	✓

LOCATION DEPENDENT

**INTERIOR WALL PERIMETER DETAILS** – For exterior details, consult the MetalWorks™ Torsion Spring Exterior installation instructions, BPLA-297922, on our website.

### Installation Detail – Wall Perimeter

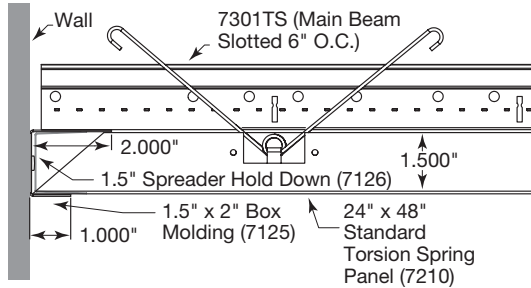

### DISCONTINUOUS SYSTEM PERIMETER DETAILS

#### Installation Detail – Extruded Perimeter Trim #7147

Recommended for use with both Sequels™ and Natural Reflections finishes. Available in Effects™ as custom finish.

#### Full Panels

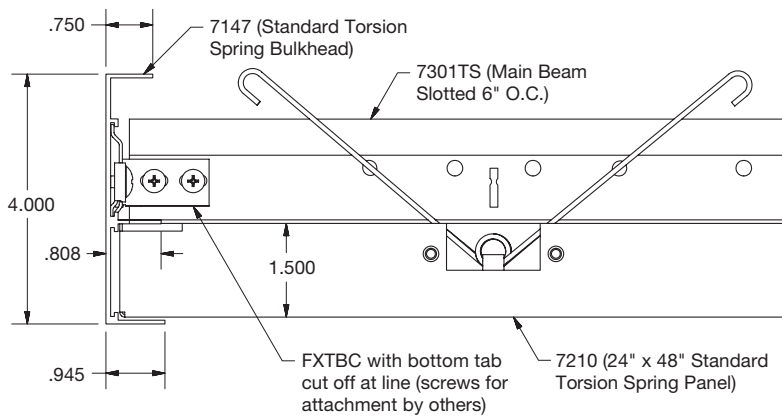

#### Cut Panels

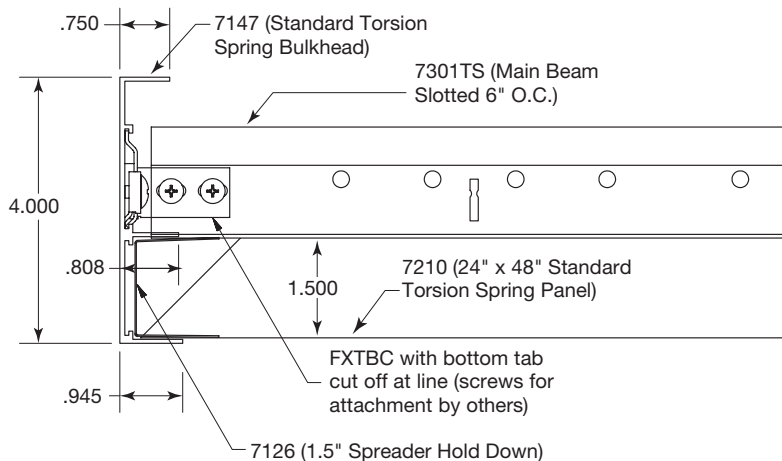

#### Installation Detail – Formed Perimeter Trim #7131

Recommended for use with LMA, BAA, and SAA finishes.

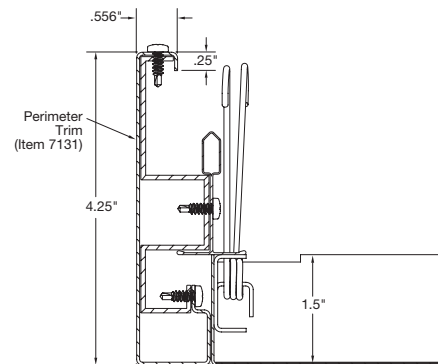

# METALWORKS™ Torsion Spring Interior and Exterior Installation Details



**LEED WELL LBC** 16% RECYCLED CONTENT

Calculate sustainability with GreenGenie™ [armstrongceilings.com/greengenie](http://armstrongceilings.com/greengenie)

- energy management
- construction waste mgmt
- regional materials
- design for flexibility
- EPD
- recyclable/extended producer resp.
- biobased materials
- recycled content
- sourcing of raw materials
- material increment reporting
- low emitting materials
- lighting quality
- acoustics

LOCATION DEPENDENT

## ACCESSORIES

	Item No. ♦	Description	Dimensions (Inches) Nominal W x L x H	Color	Pieces/ Carton
Wall-to-Wall Installs	7125__	Box Molding	2 x 96 x 1-1/2"	WHA, SIA, MYA, SAA, LMA, BAA, BL  Black is recommended for Sequels™ and Natural Reflections panel finishes  Available in Effects™ panel as custom finish	10
	7147__	Torsion Spring Perimeter Trim (Extruded)	1 x 120 x 4"	WH, SG, MY, BL*  Black is recommended for Sequels and Natural Reflections panel finishes  Available in Effects™ panel as custom finish	6
	7131__	Torsion Spring Perimeter Trim (Formed)	1 x 96 x 4-1/4"	LMA, BAA, SAA	6
Acoustical Infill Panels	5823	BioAcoustic™ Infill Panel	24 x 24 x 5/8"	Black	12
	8200T10	1" Fiberglass Infill Bag	24 x 24 x 1"	Black (Gloss)	12
Other Accessories	7129	Torsion Spring Hook Access Tool	N/A	N/A	1
	7130	Torsion Spring Suction Access Tool	N/A	N/A	1
	7126	Spreader Hold Down	1 x 10-5/8 x 1-1/2"	N/A	50

♦ When specifying or ordering, include the appropriate color code with the item number (e.g. 7131 L M A)  
\* Coordinates with WHA, SIA, MYA Torsion Spring panel finishes

# METALWORKS™ Torsion Spring Interior and Exterior Perimeter Details



**Declare.**

**LEED WELL LBC**

**16% RECYCLED CONTENT**

energy management  
construction waste mgmt  
regional materials  
design for flexibility  
EPD  
recyclable/extended producer resp.  
increased materials  
recycled content  
sourcing of raw materials  
material ingredient reporting  
low emitting materials  
lighting quality  
acoustics

▲ LOCATION DEPENDENT

Calculate sustainability with GreenGenie™  
armstrongceilings.com/greengenie

## SUSPENSION SYSTEMS

	Item No.	Description	Dimensions (Inches)
<b>15/16" Prelude® XL® Suspension System</b> Some items slotted for Torsion Spring.	7301TS	Prelude XL 12' HD Main Beam – slotted for Torsion Spring	144 x 15/16 x 1-11/16"
	XL7341TS	Prelude XL 4' Cross Tee – slotted for Torsion Spring	48 x 15/16 x 1-11/16"
	XL7390TS	Prelude XL 6' Cross Tee – slotted for Torsion Spring	72 x 15/16 x 1-11/16"
	XL7378	Prelude XL 30" Cross Tee	30 x 15/16 x 1-3/8"
	XL8320	Prelude XL 2' Cross Tee	24 x 15/16 x 1-11/16"
	XL7341	Prelude XL 4' Cross Tee	48 x 15/16 x 1-11/16"
<b>Exterior Suspension System</b> <b>15/16" Prelude XL</b> Some items slotted for Torsion Spring.	7301G90ATS	Prelude XL 12' HD Exterior Main Beam – slotted for Torsion Spring	144 x 15/16 x 1-11/16"
	XL7341G90ATS	Prelude XL 4' Exterior Cross Tee – slotted for Torsion Spring	48 x 15/16 x 1-11/16"
	XL7321G90A	Prelude XL 2' Exterior Cross Tee	24 x 15/16 x 1-11/16"

**new** LIGHTING SOLUTIONS  
**METALWORKS™** Torsion Spring  
 Center-cut Panels for Recessed Downlighting  
 smooth texture



▲ MetalWorks Torsion Spring center-cut downlight panels in Sequels - New Haven Walnut

Pre-cut durable, metal ceiling panels are designed to seamlessly integrate with trimless downlights. Perfectly centered fixtures, perfectly cut tiles—every time.

**KEY SELECTION ATTRIBUTES**

- Perfectly centered USAI® Lighting fixtures for flush-fit visual
- Coordinating fixture colors available for all standard downlight finishes
- Time and labor savings solution – downlight fixtures are fully adjustable within the system so there is no cutting, no mess, and no need to remove panels
- Entire system helps contribute to healthier spaces, part of CleanAssure™ portfolio
- Clean, minimal trimless appearance in durable, factory-cut metal panels
- Pre-cut Torsion Spring panels available in FAST134 program
- Pre-engineered and tested for fit-and-finish in all seismic areas
- For offset factory-cut panels, contact ASQuote@armstrongceilings.com. Custom grid layouts are possible depending on lighting layout.

*Now, Lighting Integration Made Easy*



DOWNLIGHTING: MetalWorks Torsion Spring center cut panel with coordinating USAI Lighting trimless downlight fixture. Integration details at [armstrongceilings.com/downlighting](http://armstrongceilings.com/downlighting)

**COLORS** Due to printing limitations, shades may vary from actual product.

Painted

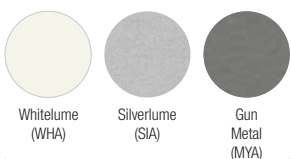

These colors are part of the Sustain™ portfolio

**new** Sequels™  
 Pre-Coat, Fast Lead Time



**PERFORATION OPTIONS**

(1:2 scale shown)

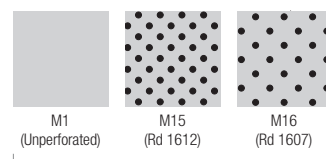

These perforations are part of the Sustain portfolio



# LIGHTING SOLUTIONS

## METALWORKS™ Torsion Spring

Center Cut Panels for Recessed Downlighting  
smooth texture

### VISUAL SELECTION

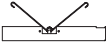
	MetalWorks Torsion Spring Panel Item No. ◆	Panel Description	USAI® Fixture Dimension (Nominal)	Coordinating USAI Fixture Family	Coordinating USAI Fixture Part No.	USAI Grid Mounting Bars Item No.
<b>METALWORKS™</b> Torsion Spring 	7209__C03__	24 x 24 x 1-1/2"	3.5" Square Downlight	BeveLED® Mini for MetalWorks	B3SXP-UA	UA2
	7209__C04__	24 x 24 x 1-1/2"	5" Square Downlight	BeveLED® 2.2 for MetalWorks	B4SXP-UA	UA2
	7210__C03__	24 x 48 x 1-1/2"	3.5" Square Downlight	BeveLED Mini for MetalWorks	B3SXP-UA	UA2 or UA4
	7210__C04__	24 x 48 x 1-1/2"	5" Square Downlight	BeveLED 2.2 for MetalWorks	B4SXP-UA	UA2 or UA4
	7211__C03__	24 x 72 x 1-1/2"	3.5" Square Downlight	BeveLED Mini for MetalWorks	B3SXP-UA	UA2
	7211__C04__	24 x 72 x 1-1/2"	5" Square Downlight	BeveLED 2.2 for MetalWorks	B4SXP-UA	UA2
	7212__C03__	24 x 96 x 1-1/2"	3.5" Square Downlight	BeveLED Mini for MetalWorks	B3SXP-UA	UA2
	7212__C04__	24 x 96 x 1-1/2"	5" Square Downlight	BeveLED 2.2 for MetalWorks	B4SXP-UA	UA2
	7213__C03__*	30 x 30 x 1-1/2"	3.5" Square Downlight	BeveLED Mini for MetalWorks	B3SXP-UA	UA2
	7213__C04__*	30 x 30 x 1-1/2"	5" Square Downlight	BeveLED 2.2 for MetalWorks	B4SXP-UA	UA2



FAST134 program items ready to ship from manufacturer in 4 weeks or less.  
Up-to-date lead times and product options (sizes and colors) at [armstrongceilings.com/fast134](http://armstrongceilings.com/fast134)

NOTE: Refer to lighting partner cut sheets for light location considerations.

- ◆ For Torsion Spring downlight item numbers, add the perforation following the base item number, and then add the 3- or 4-digit finish code. (ie: 7209 M 1 5 C 0 3 1 A)
- \* Sequels™ finishes are a custom option on this size.

### INSTALLATION DETAILS

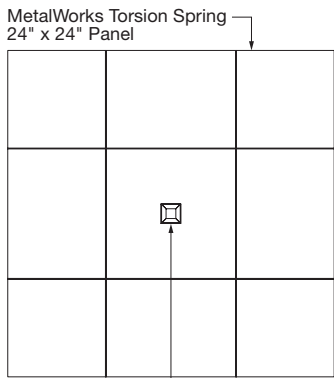

USAI BeveLED Mini for MetalWorks – Item B3SXP-UA

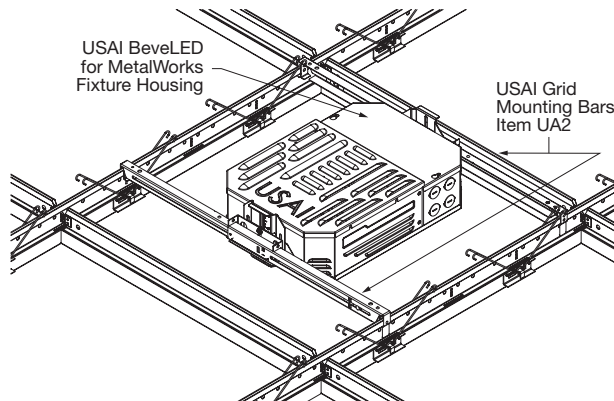

### LIGHTING FIXTURES

Compatible with USAI Lighting BeveLED 2.2 and BeveLED Mini MetalWorks fixture families.



For detailed lighting information, contact your local USAI representative or visit [usailighting.com/metalworks](http://usailighting.com/metalworks) for more information



▲ MetalWorks™ Torsion Spring and center-cut downlight panels in Sequels – Cape May Cherry

# METALWORKS™ Mesh Torsion Spring



CAD/Revit® drawings at:  
[armstrongceilings.com/CAD-REVIT](http://armstrongceilings.com/CAD-REVIT)

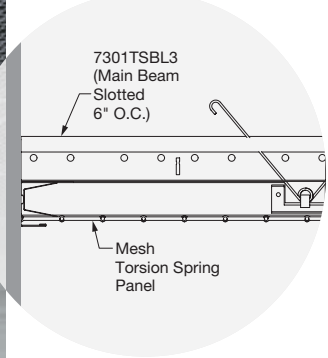

▲ MetalWorks Mesh Torsion Spring 24" x 48", 1Cell woven panels in Silver Grey; FeltWorks® wall panels in Light Grey, Dark Grey, and Beige

MetalWorks™ Mesh Torsion Spring panels offer an industrial look with minimized grid visibility and 100% swing-down accessibility.

## KEY SELECTION ATTRIBUTES

- new** Popular Torsion Spring installation method now standard in 24" x 24" and 24" x 48" woven mesh
- Slotted grid Torsion Spring installation minimizes grid visibility by hiding the grid above the panel face
- Woven patterns offer over 75% open area, enabling sprinklers to be installed above the panel face, minimizing disruption of the ceiling plan with MEP
- CleanAssure™ family of products – includes disinfectable panels, suspension systems, and trim
- Black acoustical infill panels provide high sound absorption and help conceal elements in the plenum
- For custom options contact [ASQuote@armstrongceilings.com](mailto:ASQuote@armstrongceilings.com)

## MESH FINISHES Due to printing limitations, shade may vary from actual product.

### Powder Coated

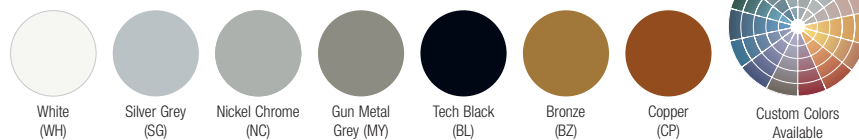

## COORDINATING SUSPENSION SYSTEM COLORS



Black (BL3)  
360° Painted

Mesh patterns leave suspension system visible.  
Black 360° grid is recommended for blending with grid and plenum.

## WOVEN DETAIL

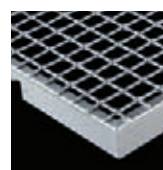



# METALWORKS™ Mesh Torsion Spring

LEED® WELL™ LBC  
UP TO 85% RECYCLED CONTENT  
Calculate sustainability with GreenGenie™ [armstrongceilings.com/greengenie](http://armstrongceilings.com/greengenie)

- energy management
- construction waste mgmt
- regional materials
- design for flexibility
- EPD
- recyclable/extended producer resp.
- biobased materials
- recycled content
- sourcing of raw materials
- material ingredient reporting
- low emitting materials
- lighting quality
- acoustics

LOCATION DEPENDENT

WITH INFILL PANEL

## VISUAL SELECTION

new

### METALWORKS™ Mesh Torsion Spring

#### Interior Panels Square 15/16"

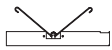

Item No. ◆	Description	Dimensions W x L x H (Inches)
5433W24L24D01__	1Cell	24 x 24 x 1/4"
5433W24L48D01__	1Cell	24 x 48 x 1/4"
5433W24L24D02__	2Cell	24 x 24 x 1/4"
5433W24L48D02__	2Cell	24 x 48 x 1/4"

## PERFORMANCE

Dots represent high level of performance.

% Open Area	Fire Rating	CleanAssure™ Disinfectable Panels		
		Fog	Spray	Wipe
76%	Class A	•	•	•
76%	Class A	•	•	•
82%	Class A	•	•	•
82%	Class A	•	•	•

## ACOUSTICAL INFORMATION

Patterns with similar open area will achieve similar acoustic results.

% Open Area	Infill Panel Item No.	Dimensions	NRC
76% & 82% Open Area	5823	24" x 24"	0.75
	1713BL	24" x 24"	0.70
	2820BK	24" x 24"	0.85
	2821BK	24" x 48"	0.85

◆ When specifying or ordering, include the appropriate 2-letter color suffix with the item number (e.g., 5433W24L24D01 S G).

## WOVEN WIRE (1:6 scale shown)

### Square Weave

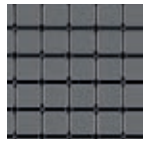

1Cell (D01)  
Item 5433  
Spacing: 0.86" x 0.86"  
Wire Diameter: 0.11"  
% Open Area: 76%

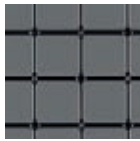

2Cell (D02)  
Item 5433  
Spacing: 1.39" x 1.39"  
Wire Diameter: 0.135"  
% Open Area: 82%

### Wire Key

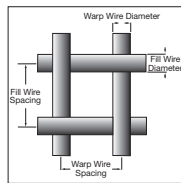

## INTERIOR WALL PERIMETER DETAILS

### Installation Detail – Wall Perimeter

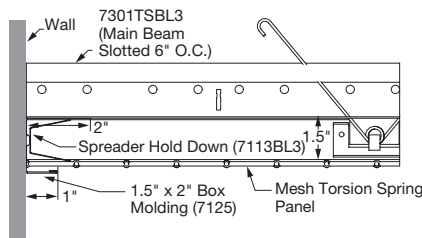

## SUSPENSION SYSTEM & ACCESSORIES

Item No.	Description	Color	Dimensions (Inches) Nominal W x L x H	Pieces/Carton
7301TSBL3	Prelude® XL® 12' HD Main Beam - Slotted	BL3	15/16 x 144 x 1-11/16"	20
7125BL3	Box Molding	BL3	2 x 96 x 1-1/2"	10
7113BL3	Hold-Down Clip	BL3	1 x 10-5/8 x 1"	40
XL8320BL3	Prelude XL 2' Cross Tee	BL3	15/16 x 24 x 1-11/16"	60

NOTE: Axiom® Classic Trim is recommended for cloud configurations.

## PHYSICAL DATA

### Material

Cold-rolled steel.

### Surface Finish

All panels are available in a range of standard and custom, factory-applied, powder-coated finishes.

### Fire Performance

Class A: ASTM E84 and CAN/ULC S102. Flame Spread Index 25 or less. Smoke Developed Index 50 or less.

All MetalWorks Mesh panels are non-combustible.

As with other architectural features located at the ceiling, Mesh panels may obstruct or skew the planned fire sprinkler water distribution pattern, or possibly delay or accelerate the activation of the sprinkler or fire detection systems by channeling the heat from a fire either toward or away from the device.

Designers and installers are advised to consult a fire protection engineer, NFPA 13, and local codes for guidance where automatic fire detection and suppression systems are present.

### Acoustics Considerations

NRC-tested using infill panels. Painted panels may experience a slight reduction in NRC due to color painting processes.

### Design Considerations

Panels align best when installed next to panels of the same size. Reveal between panels can vary.

Black 360° grid minimizes grid visibility. Axiom trim colors coordinate but are not an exact match.

Minimal deflection is expected as panels increase in size. It is possible to see up to 1/2" deflection.

### Installation Considerations

For custom design assistance contact [ASQuote@armstrongceilings.com](mailto:ASQuote@armstrongceilings.com)

Use caution and wear appropriate hand and eye protection when installing or cutting these metal panels. Refer to Installation Instructions BPLA-293095 at [armstrongceilings.com/metalworks](http://armstrongceilings.com/metalworks) for details and cutting recommendations.

### Cleaning and Disinfecting

Cleaning and CDC-approved disinfecting options available on [armstrongceilings.com/cleaning](http://armstrongceilings.com/cleaning)

### Warranty

Details at [armstrongceilings.com/warranty](http://armstrongceilings.com/warranty)

### Weight/Panel (Bulk Packed)

5433W24L24D01 - 6.8 lbs/pc

5433W24L48D01 - 12 lbs/pc

5433W24L24D02 - 5.6 lbs/pc

5433W24L48D02 - 9.8 lbs/pc

### Minimum Order Quantity

500 SF

TechLine 877 276-7876

[armstrongceilings.com/torsionspring](http://armstrongceilings.com/torsionspring)

**new** METALWORKS™ Immix™ Blades  
Panelized Torsion Spring  
smooth texture



**TOTAL ACOUSTICS™**  
Sound Absorption (NRC)  
+ Sound Blocking (CAC)



**SUSTAIN™**  
High Performance  
Sustainable  
Ceiling Systems



**24/7 DEFEND™**  
Solutions for Healthier,  
Safer Spaces



**FAST134**  
Select Items Ship Fast  
armstrongceilings.com/fast134



CAD/Revit® drawings at:  
armstrongceilings.com/cadrevit

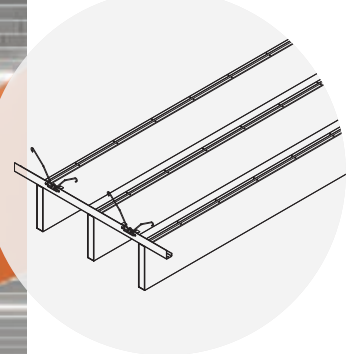

plus capabilities  
to do more



▲ MetalWorks Immix Blades 1" W x 6" H with 3 blades per panel in Silverlume

armstrongceilings.com/capabilities  
See more photos at:  
armstrongceilings.com/photogallery

A panelized torsion spring metal ceiling system in a variety of blade configurations, achieving an accessible, open reveal linear look installed up to twice as fast as individual blade systems.

**KEY SELECTION ATTRIBUTES**

- 20 standard 24" x 96" panels with multiple blades in varying heights, widths, and spacing configurations
- 1" and 2" wide blades with 4", 6", and 8" heights
- 24" x 96" torsion spring panels install up to twice as fast as individual blade systems
- Durable, downward accessible system - quickly open a large area with full panel removal
- Mix and match standard panels with alternating blade heights or widths for a custom look
- Smart design – reveals between blades are equidistant panel-to-panel; Panels have a consistent 1/8" reveal end-to-end
- MetalWorks™ Immix™ panels are part of the Sustain™ portfolio, and meet the most stringent industry sustainability compliance standards today
- CleanAssure™ family of products – includes disinfectable planks, suspension systems, and trim
- 11 panels with 70% or more open area to minimize sprinkler install and material cost, achieving a less cluttered finished ceiling with an open aesthetic
- Select products included in the FAST134 program – ready to ship in 4 weeks or less
- Panels can be field cut; perimeter cut kit and additional end caps are available for a clean, professional finish
- Black acoustical infill panels hide the plenum and achieve up to 0.95 NRC
- Get total noise control and design flexibility with Total Acoustics™ ceiling panels: NRC + CAC = Total Acoustics
- Aluminum blades with exceptional durability – washable, scrubable, soil-resistant

**COLORS** Due to printing limitations, shade may vary from actual product.

**Painted**

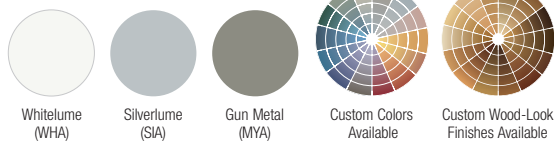

For custom options contact ASQuote,  
ASQuote@armstrongceilings.com

These colors are part of the Sustain portfolio

**PERFORATION OPTIONS** (1:2 scale shown)

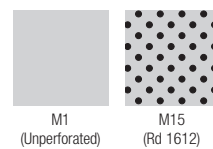

# new METALWORKS™ Immix™ Blades

Panelized Torsion Spring  
smooth texture



**LEED WELL LBC**

**16% RECYCLED CONTENT**

- energy management
- construction waste mgmt
- regional materials
- design for flexibility
- EPD
- recyclable/extended producer resp.
- bio-based materials
- recycled content
- sourcing of raw materials
- material increment reporting
- low emitting materials
- lighting quality
- acoustics

Calculate sustainability with GreenGenie™  
armstrongceilings.com/greengenie

## VISUAL SELECTION

Item No. ♦	Description	Space Between Blades	% Open Area	lbs/SF	Dimensions Nominal W x L x H (Inches) Custom Sizes Available
<b>METALWORKS™ Immix™ Blades Panels</b> 15/16" Square					
6342D41	1" wide x 4" height blade, 2 blades per panel	11"	92%†	0.36 lbs	24 x 96 x 4"
6343D41	1" wide x 4" height blade, 3 blades per panel	7"	88%†	0.54 lbs	24 x 96 x 4"
6344D41	1" wide x 4" height blade, 4 blades per panel	5"	83%†	0.73 lbs	24 x 96 x 4"
6346D41	1" wide x 4" height blade, 6 blades per panel	3"	75%	1.08 lbs	24 x 96 x 4"
6342D61	1" wide x 6" height blade, 2 blades per panel	11"	92%†	0.51 lbs	24 x 96 x 6"
6343D61	1" wide x 6" height blade, 3 blades per panel	7"	88%†	0.77 lbs	24 x 96 x 6"
6344D61	1" wide x 6" height blade, 4 blades per panel	5"	83%	1.03 lbs	24 x 96 x 6"
6346D61	1" wide x 6" height blade, 6 blades per panel	3"	75%	1.54 lbs	24 x 96 x 6"
6342D81	1" wide x 8" height blade, 2 blades per panel	11"	92%†	0.66 lbs	24 x 96 x 8"
6343D81	1" wide x 8" height blade, 3 blades per panel	7"	88%	1.08 lbs	24 x 96 x 8"
6344D81	1" wide x 8" height blade, 4 blades per panel	5"	83%	1.33 lbs	24 x 96 x 8"
<b>Other Size Panels</b>	W: 1", H: 1" – 8" 2 - 8 blades per panel	2" – 11"	Varies	Varies	W: 24** L: 24" - 96"



FAST134 program items ready to ship from manufacturer in 4 weeks or less.  
Up-to-date lead times and product options (sizes and colors) at [armstrongceilings.com/fast134](http://armstrongceilings.com/fast134)

♦ When specifying or ordering, include the appropriate 6-digit perforation suffix and color suffix (e.g., 6342D61 M 1 5 W H A).  
† Icon indicates panel with unobstructed construction where the openings are at least 70% of the cross-section area and the depth of the member does not exceed the least dimension of the openings.  
\* Panel widths other than 24" will require custom panel and suspension layout. For specific options, contact your Armstrong representative to get started with our ProjectWorks® Design Services team.

## PERFORMANCE

Dots represent high level of performance.

Sound Absorption	Fire Performance	Fog	Spray	Wipe
0.40	Class A	•	•	•
0.45	Class A	•	•	•
0.50	Class A	•	•	•
0.55	Class A	•	•	•
0.45	Class A	•	•	•
0.50	Class A	•	•	•
0.55	Class A	•	•	•
0.55	Class A	•	•	•
0.50	Class A	•	•	•
0.55	Class A	•	•	•
0.55	Class A	•	•	•
Varies	Class A	•	•	•

## ACOUSTICAL INFORMATION

Dots represent high level of performance.

Infill Panel Item No.	NRC	CAC	Total Acoustics <sup>1</sup>
8373PBBK	0.95	-	-
2821BK	0.85	35	BEST
1319	0.75	30	-

NRC with acoustical fleecce See Visual Selection chart

<sup>1</sup> Total Acoustics™ ceiling panels have an ideal combination of sound absorption and sound blocking in one product.  
GOOD (NRC 0.60-0.65; CAC 35+)  
BETTER (NRC 0.70-0.75; CAC 35+)  
BEST (NRC 0.80+; CAC 35+)

**new** METALWORKS™ Immix™ Blades

Panelized Torsion Spring  
smooth texture



Calculate sustainability with GreenGenie™  
armstrongceilings.com/greengenie



**VISUAL SELECTION**

Item No. ♦	Description	Space Between Blades	% Open Area	lbs/SF	Dimensions Nominal W x L x H (Inches) Custom Sizes Available
METALWORKS™ Immix™ Blades Panels 15/16" Square					
6342D42	2" wide x 4" height blade, 2 blades per panel	10"	83% <sup>†</sup>	0.5 lbs	24 x 96 x 4"
6343D42	2" wide x 4" height blade, 3 blades per panel	6"	75% <sup>†</sup>	0.7 lbs	24 x 96 x 4"
6344D42	2" wide x 4" height blade, 4 blades per panel	4"	67%	0.9 lbs	24 x 96 x 4"
6342D62	2" wide x 6" height blade, 2 blades per panel	10"	83% <sup>†</sup>	0.65 lbs	24 x 96 x 6"
6343D62	2" wide x 6" height blade, 3 blades per panel	6"	75% <sup>†</sup>	0.93 lbs	24 x 96 x 6"
6344D62	2" wide x 6" height blade, 4 blades per panel	4"	67%	1.2 lbs	24 x 96 x 6"
6342D82	2" wide x 8" height blade, 2 blades per panel	10"	83% <sup>†</sup>	0.8 lbs	24 x 96 x 8"
6343D82	2" wide x 8" height blade, 3 blades per panel	6"	75%	1.15 lbs	24 x 96 x 8"
6344D82	2" wide x 8" height blade, 4 blades per panel	4"	67%	1.5 lbs	24 x 96 x 8"
<b>Other Size Panels</b>	W: 2", H: 1" – 10" 2 - 6 blades per panel	2" – 10"	Varies	Varies	W: 24** L: 24" - 96"

**PERFORMANCE**

Dots represent high level of performance.

Sound Absorption	Fire Performance	Fog	Spray	Wipe
0.40	Class A	•	•	•
0.45	Class A	•	•	•
0.50	Class A	•	•	•
0.45	Class A	•	•	•
0.50	Class A	•	•	•
0.55	Class A	•	•	•
0.50	Class A	•	•	•
0.55	Class A	•	•	•
Varies	Class A	•	•	•

**ACOUSTICAL INFORMATION**

Dots represent high level of performance.

Infill Panel Item No.	NRC	CAC	Total Acoustics <sup>1</sup>
8373PBBK	0.95	-	-
2821BK	0.85	35	BEST
1319	0.75	30	-

**NRC with acoustical fleece** See Visual Selection chart

<sup>1</sup> Total Acoustics™ ceiling panels have an ideal combination of sound absorption and sound blocking in one product.  
**GOOD** (NRC 0.60-0.65; CAC 35+)  
**BETTER** (NRC 0.70-0.75; CAC 35+)  
**BEST** (NRC 0.80+; CAC 35+)













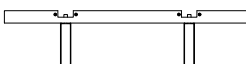

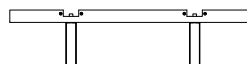

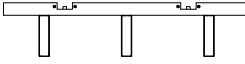



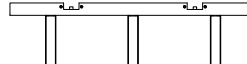
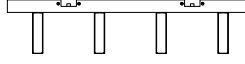

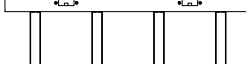
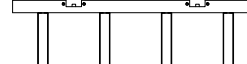
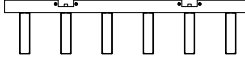



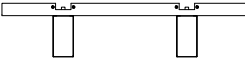

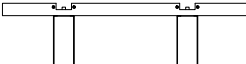
FAST134 program items ready to ship from manufacturer in 4 weeks or less.  
Up-to-date lead times and product options (sizes and colors) at [armstrongceilings.com/fast134](http://armstrongceilings.com/fast134)

♦ When specifying or ordering, include the appropriate 6-digit perforation suffix and color suffix (e.g., 6342D61 M 1 5 W H A).  
† Icon indicates panel with unobstructed construction where the openings are at least 70% of the cross-section area and the depth of the member does not exceed the least dimension of the openings.  
\* Panel widths other than 24" will require custom panel and suspension layout. For specific options, contact your Armstrong representative to get started with our ProjectWorks® Design Services team.

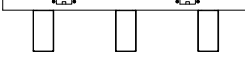
STANDARD PANEL CONFIGURATIONS

 Indicates panel with unobstructed construction where the openings are at least 70% of the cross-section area and the height of the member does not exceed the least dimension of the openings.

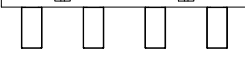
24" x 96" PANELS (1" Blade Width)			
	4" Height Blades	6" Height Blades	8" Height Blades
2 BLADES	 <p> 92% Open Area Item 6342D41</p>	 <p> 92% Open Area Item 6342D61</p>	 <p> 92% Open Area Item 6342D81</p>
3 BLADES	 <p> 88% Open Area Item 6343D41</p>	 <p> 88% Open Area Item 6343D61</p>	 <p>88% Open Area Item 6343D81</p>
4 BLADES	 <p> 83% Open Area Item 6344D41</p>	 <p>83% Open Area Item 6344D61</p>	 <p>83% Open Area Item 6344D81</p>
6 BLADES	 <p>75% Open Area Item 6346D41</p>	 <p>75% Open Area Item 6346D61</p>	

24" x 96" PANELS (2" Blade Width)			
	4" Height Blades	6" Height Blades	8" Height Blades
2 BLADES	 <p> 83% Open Area Item 6342D42</p>	 <p> 83% Open Area Item 6342D62</p>	 <p> 83% Open Area Item 6342D82</p>
3 BLADES	 <p> 75% Open Area Item 6343D42</p>	 <p> 75% Open Area Item 6343D62</p>	 <p>75% Open Area Item 6343D82</p>
4 BLADES	 <p>67% Open Area Item 6344D42</p>	 <p>67% Open Area Item 6344D62</p>	 <p>67% Open Area Item 6344D82</p>

◆ When specifying or ordering, include the appropriate 6-digit perforation suffix and color suffix (e.g., 6342D61 M 1 5 W H A).

**new** METALWORKS™ Immix™ Blades

Panelized Torsion Spring  
smooth texture

**HOW TO INSTALL PANELS**

Step 1

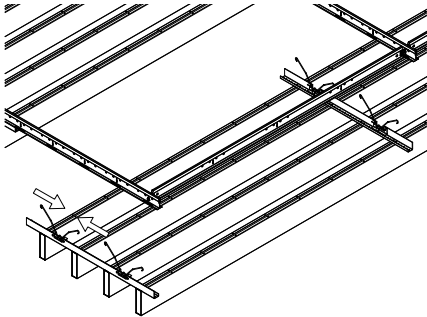

Step 2

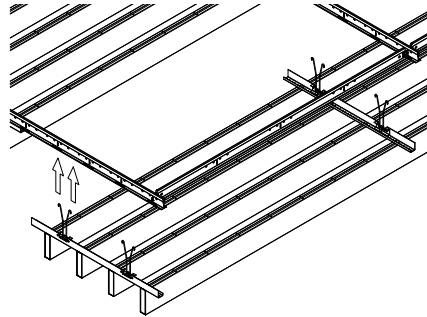

Step 3

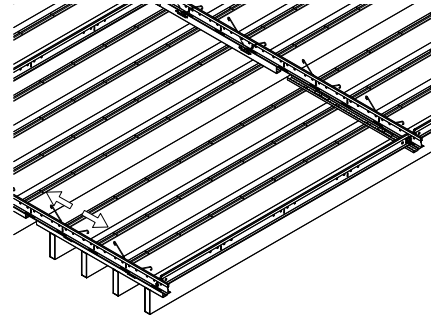

**PERIMETER CUT KIT INSTALLATION**

Step 1

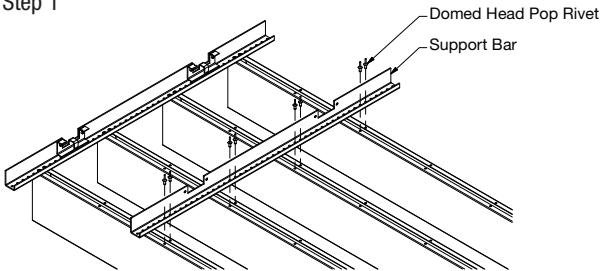

Step 2

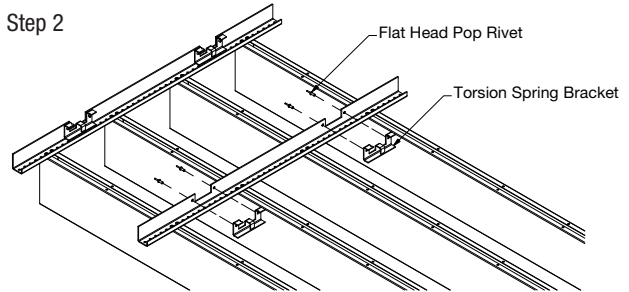

Step 3

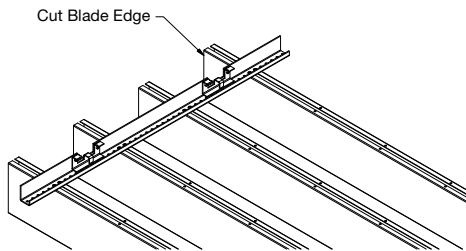

Step 4

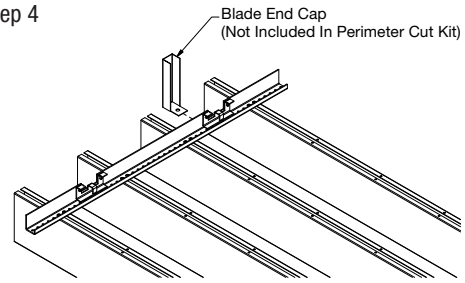

**AXIOM® FLOATING PERIMETER DETAIL**

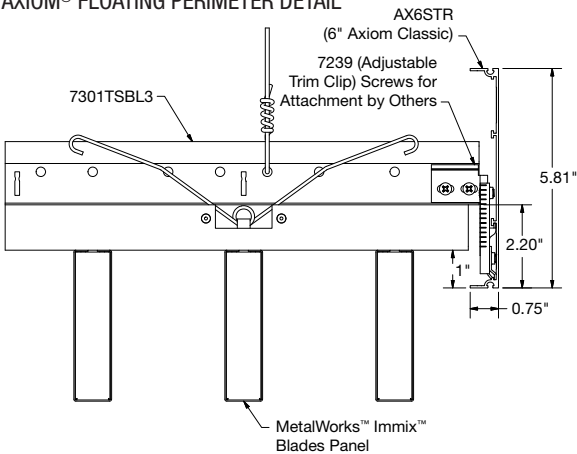

**SUSPENSION SYSTEM & ACCESSORIES**

	Item No. ◆	Description	Dimensions (Inches) Nominal W x L x H	Color	Pieces/Carton
Suspension Systems	7301TS	Prelude® XL® 12' HD Main Beam – Slotted	15/16 x 144 x 1-11/16"	White	20
	XL7341	Prelude XL 4' Cross Tee	15/16 x 48 x 1-11/16"	White	60
	7301TSBL3	Black 360 Prelude XL 12' HD Main Beam – Slotted	15/16 x 144 x 1-11/16"	Black	20
	XL734036BL	Black 360 Prelude XL 4' Cross Tee	15/16 x 48 x 1-11/16"	Black	60
Wall-to- Wall Installations	7800	12' Angle Molding	N/A	White	30
	HD7801__	10' Angle Molding	N/A	Silver Grey, Gun Metal	30
	BERC2	2" Beam End Retaining Clip	N/A	N/A	200
Floating Cloud Installations	AX6STR__	Axiom® Vector 6" Straight Trim	N/A	White, Silver Grey, Gun Metal	N/A
	7239	Adjustable Trim Clip (ATC)	N/A	N/A	50
Other Accessories	5604	Perimeter Cut Kit	N/A	N/A	10 support bars/20 brackets/40 countersunk rivets, 120 domed head rivets

◆ Add the 2-digit color suffix to the item number when specifying or ordering (e.g. AX6STR S G), add an extra digit "3" before the color suffix if paint is required inside and outside of trim (e.g. AX6STR 3 S G).

**ACCESSORIES**

Item No. ◆	Description	Pieces/ Carton	Item No. ◆	Description	Pieces/ Carton
5458D41M1__	1" wide x 4" height end cap	10	5458D42M1__	2" wide x 4" height end cap	10
5458D61M1__	1" wide x 6" height end cap	10	5458D62M1__	2" wide x 6" height end cap	10
5458D81M1__	1" wide x 8" height end cap	10	5458D82M1__	2" wide x 8" height end cap	10

◆ When specifying or ordering, include the appropriate 3-letter color suffix (e.g., 5458D61M1 M Y A).

**PHYSICAL DATA**

**Material**  
Aluminum – thickness 0.032"

**Surface Finish**  
Painted: Factory-applied polyester paint. Custom colors also available. Contact ASQuote@armstrongceilings.com for custom finish requests.

**Fire Performance**  
Class A: Tested per ASTM E84. Flame Spread Index 25 or less. Smoke Developed Index 50 or less. CAN/ULC S102 surface burning characteristics. Flame Spread Rating 25 or less. Smoke Developed Classification 50 or less.

**Acoustical Options**  
Perforated panels are supplied with a black fiberglass fleece to absorb sound.

**Design Support**  
For custom design assistance contact ProjectWorks® Design Services or visit armstrongceilings.com/projectworks

**Design Considerations**  
When installed, panels hang either 5-3/16", 7-3/16" or 9-3/16" below the face of the grid, depending on the height of the blade. MetalWorks™ Immix™ Blades panels can be cut in the field, see installation instructions for details.  
Variation in reveal between panel ends up to 1/16" may occur  
Black 360® grid minimizes grid visibility. Axiom trim colors coordinate but are not an exact match.  
For optimum visual design, backlighting panels is not recommended. For lighting integration see installation instructions.

**Installation Considerations**  
Although panels are installed from below and never travel into the plenum, MetalWorks Immix Blades panels will require a minimum 5" clearance above the suspension system. This allows enough room for the springs to travel into the plenum space during installation or removal.

**Seismic Restraint**  
MetalWorks Immix panels are approved for application in all seismic areas when installed per the seismic guidelines in the Armstrong Ceilings installation instructions.

**FAST134 Program Considerations**  
Size of Job Matters: Big jobs, over 2500 SF or 50 pieces for shapes/vertical elements will have longer lead times.  
Location Matters: Transit time not included. We are ready to ship in 1 week on FAST1 items. However, transit to the states west of Wyoming may add time.  
Distributor Truck Schedule Matters: We rely on distribution to help move products around the country. When speed matters, work with your local distributor to ensure FAST134 service.  
Stock vs. Made-to-order Matters: FAST3 & FAST4 items are made-to-order and will ship direct to distributor. FAST1 (stocked items) will go through distribution and depend on distributor truck schedules.

**Cleaning and Disinfecting**  
Cleaning and CDC-approved disinfecting options available on armstrongceilings.com/cleaning

**Warranty**  
Details at armstrongceilings.com/warranty

**Weight**  
Refer to Visual Selection chart



# METALWORKS™ Immix™ Linear

Panelized Torsion Spring  
smooth texture



**TOTAL  
ACOUSTICS™**  
Sound Absorption (NRC)  
+ Sound Blocking (CAC)



**SUSTAIN™**  
High Performance  
Sustainable  
Ceiling Systems



**24/7  
DEFEND™**  
Solutions for Healthier,  
Safer Spaces



**FAST134**  
Select Items Ship Fast  
[armstrongceilings.com/fast134](http://armstrongceilings.com/fast134)



CAD/Revit® drawings at:  
[armstrongceilings.com/cadrevit](http://armstrongceilings.com/cadrevit)

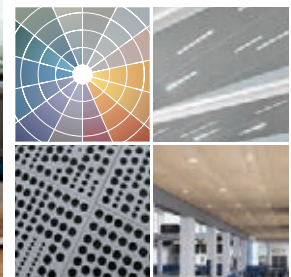
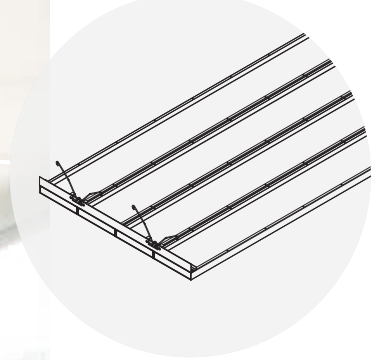

▲ MetalWorks Immix Linear perforated 6" W x 1" H plank with 4 planks per panel in Whitelume

[armstrongceilings.com/capabilities](http://armstrongceilings.com/capabilities)  
See more photos at:  
[armstrongceilings.com/photogallery](http://armstrongceilings.com/photogallery)

A panelized torsion spring metal ceiling system in a variety of linear configurations, achieving an accessible, smooth monolithic or open reveal linear look installed up to twice as fast as individual plank systems.

## KEY SELECTION ATTRIBUTES

- 21 standard 24" x 96" panels with multiple linear planks in varying heights and widths with planks per panel configurations
- Nominal 4", 6", 8", 10", and 12" wide planks with 1", 2", 4", 6" or 8" heights
- 24" x 96" torsion spring panels install up to twice as fast as individual linear plank systems
- Durable, downward accessible system – quickly open a large area with full panel removal
- Mix and match standard panels with alternating plank heights or widths for a custom look
- Smart design – reveals between planks are equidistant panel-to-panel; Panels have a consistent 1/8" reveal end-to-end
- MetalWorks™ Immix™ panels are part of the Sustain™ portfolio, and meet the most stringent industry sustainability compliance standards today
- CleanAssure™ family of products – includes disinfectable planks, suspension systems, and trim
- Select products included in the FAST134 program – ready to ship in 4 weeks or less
- Panels can be field cut; perimeter cut kit and additional end caps are available for a clean, professional finish
- Black acoustical infill panels hide the plenum and achieve up to 0.95 NRC
- Get total noise control and design flexibility with Total Acoustics™ ceiling panels: NRC + CAC = Total Acoustics
- Aluminum planks with exceptional durability – washable, scrubable, soil-resistant

**COLORS** Due to printing limitations, shade may vary from actual product.

### Painted

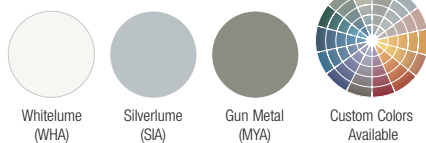

For custom options contact ASQuote,  
[ASQuote@armstrongceilings.com](mailto:ASQuote@armstrongceilings.com)

These colors are part of the Sustain portfolio

**PERFORATION OPTIONS** (1:2 scale shown)

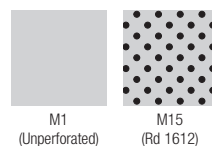



**new** METALWORKS™ Immix™ Linear

Panelized Torsion Spring  
smooth texture



**LEED WELL LBC**  
16% RECYCLED CONTENT

energy management  
construction waste mgmt  
regional materials  
design for flexibility  
EPD  
recyclable/extended producer resp.  
biobased materials  
recycled content  
sourcing of raw materials  
material increment reporting  
low emitting materials  
lighting quality  
acoustics

LOCATION DEPENDENT

Calculate sustainability with GreenGenie™  
armstrongceilings.com/greengenie

**VISUAL SELECTION**

Item No. ♦	Description	Space Between Planks (Nominal)	% Open Area	lbs/ SF	Dimensions Nominal W x L x D (Inches) Custom Sizes Available
METALWORKS™ Immix™ Linear Panels 15/16" Square					
6374A41	4" wide x 1" height plank, 4 planks per panel	2-1/8"	33%	0.58 lbs	24 x 96 x 1"
6376A41	4" wide x 1" height plank, 6 planks per panel	1/8"	0%	0.82 lbs	24 x 96 x 1"
6373A42	4" wide x 2" height plank, 3 planks per panel	4-1/8"	50%	0.57 lbs	24 x 96 x 2"
6374A42	4" wide x 2" height plank, 4 planks per panel	2-1/8"	33%	0.73 lbs	24 x 96 x 2"
6372A44	4" wide x 4" height plank, 2 planks per panel	8-1/8"	67%	0.56 lbs	24 x 96 x 4"
6373A44	4" wide x 4" height plank, 3 planks per panel	4-1/8"	50%	0.80 lbs	24 x 96 x 4"
6374A44	4" wide x 4" height plank, 4 planks per panel	2-1/8"	33%	1.03 lbs	24 x 96 x 4"
6373A61	6" wide x 1" height plank, 3 planks per panel	2-1/8"	25%	0.58 lbs	24 x 96 x 1"
6374A61	6" wide x 1" height plank, 4 planks per panel	1/8"	0%	0.73 lbs	24 x 96 x 1"
6373A62	6" wide x 2" height plank, 3 planks per panel	2-1/8"	25%	0.69 lbs	24 x 96 x 2"
6372A64	6" wide x 4" height plank, 2 planks per panel	6-1/8"	50%	0.64 lbs	24 x 96 x 4"
Other Size Panels	W: 4" – 12" H: 1" – 8"	1/8" – 8-1/8"	Varies	Varies	W: 24** L: 24" - 96"

**PERFORMANCE**

Dots represent high level of performance.

Sound Absorption (M1 White only)	Light Reflect	Fire Performance	CleanAssure™ Disinfectable Planks		
			Fog	Spray	Wipe
0.70	0.75	Class A	•	•	•
0.75	0.75	Class A	•	•	•
0.65	0.75	Class A	•	•	•
0.70	0.75	Class A	•	•	•
0.60	0.75	Class A	•	•	•
0.65	0.75	Class A	•	•	•
0.70	0.75	Class A	•	•	•
0.70	0.75	Class A	•	•	•
0.75	0.75	Class A	•	•	•
0.70	0.75	Class A	•	•	•
0.65	0.75	Class A	•	•	•
Varies	0.75	Class A	•	•	•

**ACOUSTICAL INFORMATION**

Dots represent high level of performance.

Infill Panel Item No.	NRC	CAC	Total Acoustics <sup>1</sup> NRC + CAC
Over 8373PBBK	0.95	-	-
30%	•	-	-
Open 2821BK	0.85	35	BEST
Area*	•	•	•
1319	0.75	30	-

NRC with See Visual Selection chart  
acoustical fleece

\* Infill options for fleece-only panels with less than 30% open area can be installed for additional sound absorption.  
<sup>1</sup> Total Acoustics™ ceiling panels have an ideal combination of sound absorption and sound blocking in one product.  
**GOOD** (NRC 0.60-0.65; CAC 35+)  
**BETTER** (NRC 0.70-0.75; CAC 35+)  
**BEST** (NRC 0.80+; CAC 35+)



FAST134 program items ready to ship from manufacturer in 4 weeks or less.  
Up-to-date lead times and product options (sizes and colors) at [armstrongceilings.com/fast134](http://armstrongceilings.com/fast134)

♦ When specifying or ordering, include the appropriate 6-digit perforation suffix and color suffix (e.g., 6373A44 M 1 5 W H A).  
 \* Panel widths other than 24" will require custom panel and suspension layout. For specific options, contact your Armstrong representative to get started with our ProjectWorks® Design Services team.

**new** METALWORKS™ Immix™ Linear  
Panelized Torsion Spring  
smooth texture



Calculate sustainability with GreenGenie™  
armstrongceilings.com/greengenie



**VISUAL SELECTION**

Item No. ♦	Description	Space Between Planks (Nominal)	% Open Area	lbs/SF	Dimensions Nominal W x L x D (Inches) Custom Sizes Available
METALWORKS™ Immix™ Linear Panels 15/16" Square 					
6373A64	6" wide x 4" height plank, 3 planks per panel	2-1/8"	25%	0.91 lbs	24 x 96 x 4"
6372A66	6" wide x 6" height plank, 2 planks per panel	6-1/8"	50%	0.79 lbs	24 x 96 x 6"
6372A81	8" wide x 1" height plank, 2 planks per panel	4-1/8"	33%	0.49 lbs	24 x 96 x 1"
6373A81	8" wide x 1" height plank, 3 planks per panel	1/8"	0%	0.69 lbs	24 x 96 x 1"
6372A82	8" wide x 2" height plank, 2 planks per panel	4-1/8"	33%	0.56 lbs	24 x 96 x 2"
6372A84	8" wide x 4" height plank, 2 planks per panel	4-1/8"	33%	0.72 lbs	24 x 96 x 4"
6372A86	8" wide x 6" height plank, 2 planks per panel	4-1/8"	33%	0.87 lbs	24 x 96 x 6"
6372A88	8" wide x 8" height plank, 2 planks per panel	4-1/8"	33%	1.02 lbs	24 x 96 x 8"
6372AA1	10" wide x 1" height plank, 2 planks per panel	2-1/8"	17%	0.56 lbs	24 x 96 x 1"
6372AC1	12" wide x 1" height plank, 2 planks per panel	1/8"	0%	0.64 lbs	24 x 96 x 1"
Other Size Panels	W: 4" – 12" H: 1" – 8"	1/8" – 8-1/8"	Varies	Varies	W: 24** L: 24" – 96"

**PERFORMANCE**

Dots represent high level of performance.

Sound Absorption (M1 White only)	Light Reflect	Fire Performance	Fog	Spray	Wipe
0.70 •	0.75	Class A	•	•	•
0.65	0.75	Class A	•	•	•
0.70 •	0.75	Class A	•	•	•
0.75 •	0.75	Class A	•	•	•
0.70 •	0.75	Class A	•	•	•
0.70 •	0.75	Class A	•	•	•
0.70 •	0.75	Class A	•	•	•
0.70 •	0.75	Class A	•	•	•
0.70 •	0.75	Class A	•	•	•
0.70 •	0.75	Class A	•	•	•
0.70 •	0.75	Class A	•	•	•
Varies	0.75	Class A	•	•	•

**ACOUSTICAL INFORMATION**

Dots represent high level of performance.

Infill Panel Item No.	NRC	CAC	Total Acoustics <sup>1</sup>
Over 30% Open Area*	8373PBBK 0.95	–	–
	2821BK 0.85	35	BEST
	1319 0.75	30	–

**NRC with acoustical fleece** See Visual Selection chart





\* Infill options for fleece-only panels with less than 30% open area can be installed for additional sound absorption.  
<sup>1</sup> Total Acoustics™ ceiling panels have an ideal combination of sound absorption and sound blocking in one product.  
**GOOD** (NRC 0.60-0.65; CAC 35+)  
**BETTER** (NRC 0.70-0.75; CAC 35+)  
**BEST** (NRC 0.80+; CAC 35+)

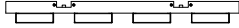
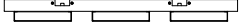

FAST134 program items ready to ship from manufacturer in 4 weeks or less.  
Up-to-date lead times and product options (sizes and colors) at [armstrongceilings.com/fast134](http://armstrongceilings.com/fast134)

♦ When specifying or ordering, include the appropriate 6-digit perforation suffix and color suffix (e.g., 6373A44 M 1 5 W H A).  
 \* Panel widths other than 24" will require custom panel and suspension layout. For specific options, contact your Armstrong representative to get started with our ProjectWorks® Design Services team.

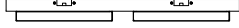
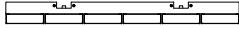
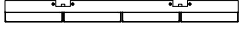
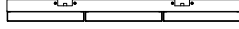
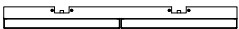
STANDARD PANEL CONFIGURATIONS

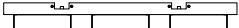
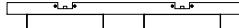
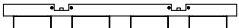
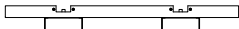
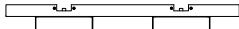
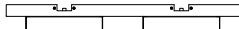
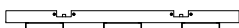
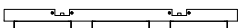
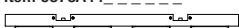
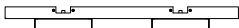
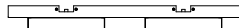
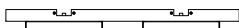
24" x 96" PANELS					
	4" Nominal Wide Planks	6" Nominal Wide Planks	8" Nominal Wide Planks	10" Nominal Wide Planks	12" Nominal Wide Planks
1" HEIGHT PLANK	 33% Open Area 4 Planks per Panel Item 6374A41	 25% Open Area 3 Planks per Panel Item 6373A61	 33% Open Area 2 Planks per Panel Item 6372A81	 17% Open Area 2 Planks per Panel Item 6372AA1	
	 0% Open Area 6 Planks per Panel Item 6376A41 *	 0% Open Area 4 Planks per Panel Item 6374A61 *	 0% Open Area 3 Planks per Panel Item 6373A81 *		 0% Open Area 2 Planks per Panel Item 6372AC1 *
2" HEIGHT PLANK	 50% Open Area 3 Planks per Panel Item 6373A42	 25% Open Area 3 Planks per Panel Item 6373A62	 33% Open Area 2 Planks per Panel Item 6372A82		
	 33% Open Area 4 Planks per Panel Item 6374A42				
4" HEIGHT PLANK	 67% Open Area 2 Planks per Panel Item 6372A44	 50% Open Area 2 Planks per Panel Item 6372A64	 33% Open Area 2 Planks per Panel Item 6372A84		
	 50% Open Area 3 Planks per Panel Item 6373A44	 25% Open Area 3 Planks per Panel Item 6373A64			
	 33% Open Area 4 Planks per Panel Item 6374A44				
6" HEIGHT PLANK		 50% Open Area 2 Planks per Panel Item 6372A66	 33% Open Area 2 Planks per Panel Item 6372A86		
8" HEIGHT PLANK			 33% Open Area 2 Planks per Panel Item 6372A88		

◆ When specifying or ordering, include the appropriate 6-digit perforation suffix and color suffix (e.g., 6342D61 M 1 5 W H A).  
\* These 1/8" reveal configurations should only be installed with like panels and not with planks of other sizes.

**new** METALWORKS™ Immix™ Linear

Panelized Torsion Spring  
smooth texture

HOW TO INSTALL PANELS

Step 1

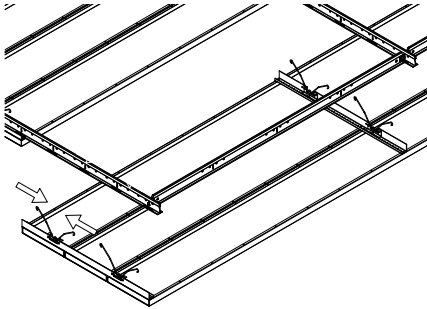

Step 2

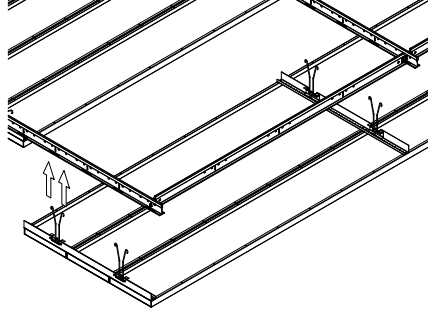

Step 3

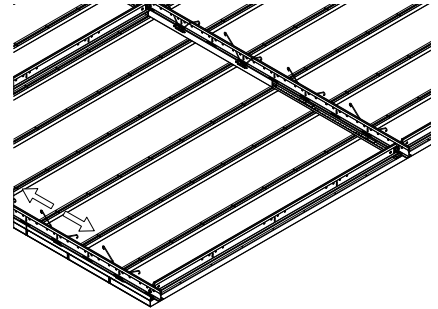

PERIMETER CUT KIT INSTALLATION

Step 1

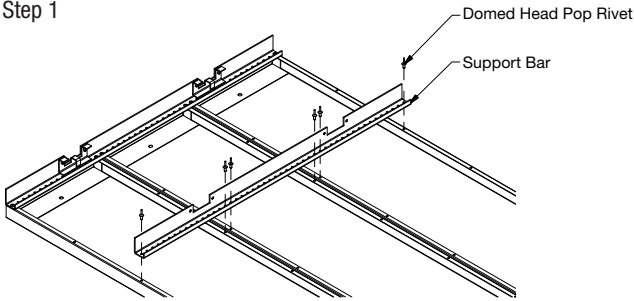

Step 2

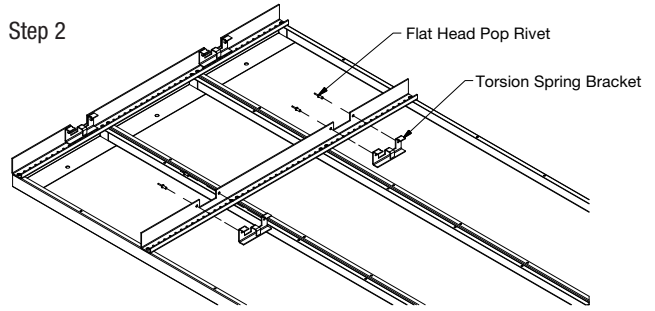

Step 3

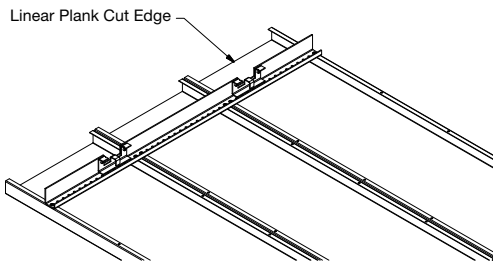

Step 4

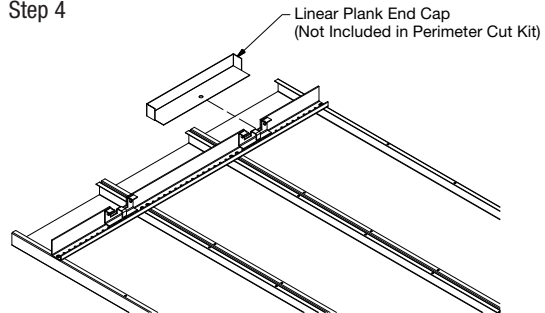

AXIOM® FLOATING PERIMETER DETAIL

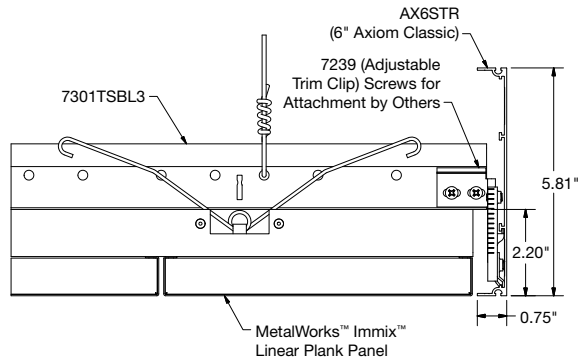

energy management construction waste mgmt regional materials design for flexibility EPD recyclable/extended producer resp. biobased materials recycled content sourcing of raw materials material ingredient reporting low emitting materials lighting quality acoustics

LOCATION DEPENDENT

WHITE ONLY WITH INFILL PANEL

**SUSPENSION SYSTEM & ACCESSORIES**

	Item No. ♦	Description	Dimensions (Inches) Nominal W x L x H	Color	Pieces/Carton
Suspension Systems	7301TS	Prelude® XL® 12' HD Main Beam – Slotted	15/16 x 144 x 1-11/16"	White	20
	XL7341	Prelude XL 4' Cross Tee	15/16 x 48 x 1-11/16"	White	60
	7301TSBL3	Black 360 Prelude XL 12' HD Main Beam – Slotted	15/16 x 144 x 1-11/16"	Black	20
	XL734036BL	Black 360 Prelude XL 4' Cross Tee	15/16 x 48 x 1-11/16"	Black	60
Wall-to- Wall Installations	7800	12' Angle Molding	N/A	White	30
	HD7801__	10' Angle Molding	N/A	Silver Grey, Gun Metal	30
	BERC2	2" Beam End Retaining Clip	N/A	N/A	200
Floating Cloud Installations	AX6STR__♦	Axiom® Vector 6" Straight Trim		White, Silver Grey, Gun Metal	
	7239	Adjustable Trim Clip (ATC)	N/A	N/A	50
Other Accessories	5604	Perimeter Cut Kit	N/A	N/A	10 support bars/20 brackets/40 countersunk rivets, 120 domed head rivets
	7129	Torsion Spring Hook Access Tool	N/A	N/A	1

♦ Add the 2-digit color suffix to the item number when specifying or ordering (e.g. AX6STR S G), add an extra digit "3" before the color suffix if paint is required inside and outside of trim (e.g. AX6STR 3 S G).

**ACCESSORIES**

Item No. ♦	Description	Pieces/ Carton	Item No.	Description	Pieces/ Carton
5459A41M1__	4" wide x 1" height end cap	10	5459A81M1__	8" wide x 1" height end cap	10
5459A42M1__	4" wide x 2" height end cap	10	5459A82M1__	8" wide x 2" height end cap	10
5459A44M1__	4" wide x 4" height end cap	10	5459A84M1__	8" wide x 4" height end cap	10
5459A61M1__	6" wide x 1" height end cap	10	5459A86M1__	8" wide x 6" height end cap	10
5459A62M1__	6" wide x 2" height end cap	10	5459A88M1__	8" wide x 8" height end cap	10
5459A64M1__	6" wide x 4" height end cap	10	5459AA1M1__	10" wide x 1" height end cap	10
5459A66M1__	6" wide x 6" height end cap	10	5459AC1M1__	12" wide x 1" height end cap	10

♦ When specifying or ordering, include the appropriate 3-letter color suffix (e.g., 5459A61M1 M Y A).

**PHYSICAL DATA**

**Material**  
Aluminum – thickness 0.032"

**Surface Finish**  
Painted: Factory-applied polyester paint. Custom colors also available. Contact ASQuote@armstrongceilings.com for custom finish requests.

**Fire Performance**  
Class A: Tested per ASTM E84. Flame Spread Index 25 or less. Smoke Developed Index 50 or less. CAN/ULC S102 surface burning characteristics. Flame Spread Rating 25 or less. Smoke Developed Classification 50 or less.

**Acoustical Options**  
Perforated panels are supplied with a black fiberglass fleece to absorb sound.

**Design Support**  
For custom design assistance contact ProjectWorks® Design Services or visit armstrongceilings.com/projectworks

**Design Considerations**  
When installed, panels hang either 2-3/16", 3-3/16", 5-3/16", 7-3/16" or 9-3/16" below the face of the grid, depending on the height of the plank. MetalWorks™ Immix™ Linear panels can be cut in the field, see installation instructions for details.  
Variation in reveal between panel ends up to 1/16" may occur.  
Black 360° grid minimizes grid visibility. Axiom trim colors coordinate but are not an exact match.  
For optimum visual design, backlighting panels is not recommended. For lighting integration see installation instructions.

**Installation Considerations**  
Although panels are installed from below and never travel into the plenum, MetalWorks Immix Linear panels will require a minimum 5" clearance above the suspension system. This allows enough room for the springs to travel into the plenum space during installation or removal.

**Seismic Restraint**  
MetalWorks Immix panels are approved for application in all seismic areas when installed per the seismic guidelines in the Armstrong Ceilings installation instructions.

**Cleaning and Disinfecting**  
Cleaning and CDC-approved disinfecting options available on armstrongceilings.com/cleaning

**Warranty**  
Details at armstrongceilings.com/warranty

**FAST134 Program Considerations**  
Size of Job Matters: Big jobs, over 2500 SF or 50 pieces for shapes/vertical elements will have longer lead times.  
Location Matters: Transit time not included. We are ready to ship in 1 week on FAST1 items. However, transit to the states west of Wyoming may add time.  
Distributor Truck Schedule Matters: We rely on distribution to help move products around the country. When speed matters, work with your local distributor to ensure FAST134 service.  
Stock vs. Made-to-Order Matters: FAST3 & FAST4 items are made-to-order and will ship direct to distributor. FAST1 (stocked items) will go through distribution and depend on distributor truck schedules.

**Weight**  
Refer to Visual Selection chart

# TAKE THE NEXT STEP

## 1 877 276-7876

Customer Service Representatives  
7:45 a.m. to 5:00 p.m. EST  
Monday through Friday

**TechLine** – Technical information, detail drawings, CAD design assistance, installation information, other technical services – 8:00 a.m. to 5:30 p.m. EST, Monday through Friday. FAX 1 800 572 8324 or email: [techline@armstrongceilings.com](mailto:techline@armstrongceilings.com)

## [armstrongceilings.com/commercial](http://armstrongceilings.com/commercial)

Latest product news

Standard and custom product information

Online catalog

CAD, Revit®, SketchUp® files

A Ceiling for Every Space® Visual Selection Tool

Product literature and samples – express service or regular delivery

Contacts – reps, where to buy, who will install

## ProjectWorks™

### [armstrongceilings.com/projectworks](http://armstrongceilings.com/projectworks)

The power of PROJECTWORKS® Design and Pre-Construction Service

Mix and match different sizes, shapes, colors, and materials to reinvent your standard, specialty, or custom ceiling.

Visit our pattern gallery online to see ideas for your next project. [armstrongceilings.com/patterngallery](http://armstrongceilings.com/patterngallery)

Contact your local representative to get a design started! Not sure who your local rep is?

Visit [armstrongceilings.com/findarep](http://armstrongceilings.com/findarep)

Revit® is a registered trademark of Autodesk, Inc.; SketchUp® is a registered trademark of Trimble Navigation Limited; LEED® is a registered trademark of the U.S. Green Building Council; Declare® and Living Building Challenge® (LBC) are trademarks of the International Living Future Institute; WELL™ and Well Building Standard are trademarks of the International WELL Building Institute; BeveLED® and USAI® are registered trademarks of USAI, LLC. All other trademarks used herein are the property of AWI Licensing LLC and/or its affiliates.

© 2022 AWI Licensing LLC Printed in the United States of America

[armstrongceilings.com/torsionspring](http://armstrongceilings.com/torsionspring)

  
CEILING & WALL SOLUTIONS