

SEISMIC CEILING INSTALLATION

What You Need to Know

Code Requirements
Seismic Rx
Tested Solutions



Armstrong[®]
CEILING & WALL SOLUTIONS

CURRENT SEISMIC CODE: DEVELOPMENT AND ADOPTION

The Code Official's Role

The building code presents minimum design/performance requirements and in some instances prescriptive guidance. The code also sets forth limitations and conditions of use. It is important to know that while the building code establishes the requirements, the code official has the power to enforce its provisions. Code officials also have the latitude to allow materials and methods of construction that are not addressed in the code. Code officials can perform their own analysis of evidence presented or can rely on independent, qualified sources such as ICC-ES to do the analysis and provide their findings.

Purpose of Installation Requirements for Suspended Ceilings

- ▶ Provide a suspension system strong enough to resist lateral forces imposed upon it without failing
- ▶ Prevent border panels from falling from the ceiling plane

Federal Emergency Management Agency (FEMA)

Seismic performance during large California earthquakes prompted FEMA to address suspended ceiling performance during a seismic event. Research and tests demonstrated that industry seismic standards (UBC Standard 25-2) were not adequate. To support individual panels around the perimeter, FEMA determined that the key to good seismic performance is a wider wall molding on all sides. This led to the International Building Code requirement for 2" wall molding on all sides.

Source: FEMA 302 NEHRP Recommended Provisions for Seismic Regulations for New Buildings and Other Structures

Adoption of the International Building Code

Currently all 50 states as well as Washington, D.C. and the Virgin Islands use the International Building Code.

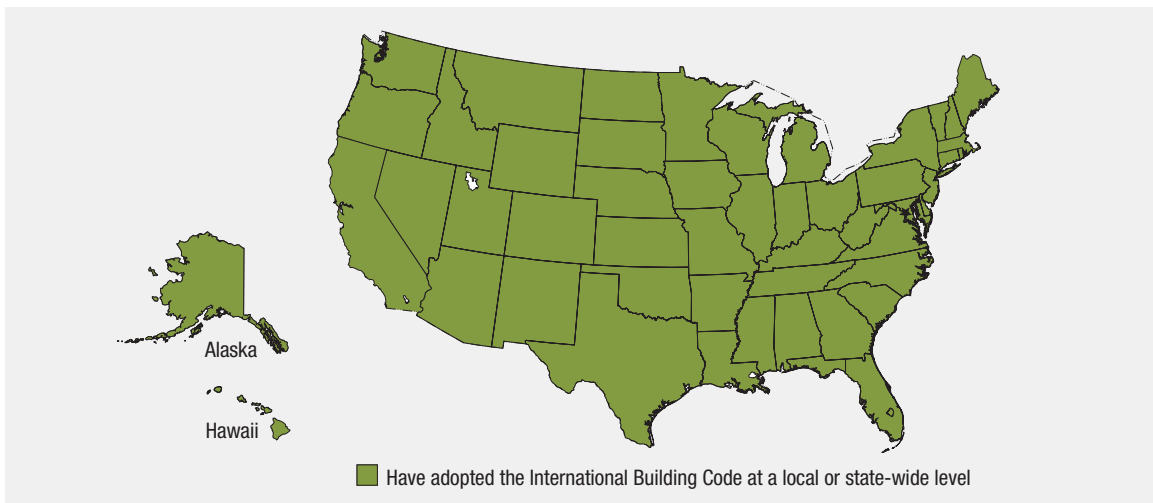

Source: <http://www.iccsafe.org/gr/content/pages/gr-map.aspx> (May 2010)

ICC makes every effort to provide current, accurate code adoption information, but in some cases, jurisdictions do not notify ICC of adoptions, amendments, or changes to their codes.

How Seismic Design Categories Are Determined

The seismic design category must be specified by a professional engineer or registered architect on the project drawings per ASCE 7. The project requirements which include the seismic design category can be found in Section 1 of the specification, and on the first page of the structural drawings.

International Building Code (IBC) allows two paths to determine Seismic Design Category – IBC Section 1613 or ASCE 7 Section 11.6. The IBC states that a Seismic Design Category must be established for each construction project based on:

- ▶ **Anticipated ground motion**
- ▶ **Soil type in a specified geographic area**
- ▶ **Occupancy category**

These factors are used to evaluate and establish a Seismic Design Category of A, B, C, D, E, or F. The installation of ceilings can be divided into three tiers of increasing requirements:

- ▶ **Categories A & B are installed to meet requirements established in ASTM C636**
- ▶ **Category C projects must meet those plus additional provisions listed in ASTM E580**
- ▶ **Categories D, E & F must follow ASTM C636 and ASTM E580**

NOTE: Seismic categories are determined for the entire building. This is why the Seismic Design Category information is on the structural drawings.

SUMMARY OF IBC SEISMIC INSTALLATION REQUIREMENTS

IBC CATEGORY	IBC INSTALLATION REQUIREMENTS
A, B	Ceiling installation should conform to basic minimums established in ASTM C636. <ul style="list-style-type: none"> • 12ga. hanger wires, minimum • Hanger wires spaced 4ft on center, maximum, along main beams • Hanger wires supporting main beams must be wrapped around themselves a minimum of three full turns within a 3" length • Hanger wires shall not hang more than one-in-six out-of-plumb, unless a counter-sloping wire or horizontal brace is provided
C	Installed to ASTM E580 Seismic Design Category C. <ul style="list-style-type: none"> • Minimum 7/8" wall molding • Suspension system must not be attached to the wall molding • Minimum 3/8" clearance on all sides • Minimum 3/8" overlap of the suspension system on the wall molding • Ends of main beams and cross tees must be tied together to prevent their spreading • Safety wires required on light fixtures
D, E, F	Installed to ASTM C636 and ASTM E580 <ul style="list-style-type: none"> • Minimum 2" wall molding • Suspension system must be attached to two adjacent walls – opposite walls must have a 3/4" clearance • Ends of main beams and cross tees must be tied together to prevent their spreading • Heavy-duty suspension system • Ceiling areas over 1,000 SF must have horizontal restraint wire or rigid bracing • Ceiling areas over 2,500 SF must have seismic separation joints or full height partitions • Ceilings without rigid bracing must have 2" oversized trim rings for sprinklers and other penetrations • Changes in ceiling plane must have positive bracing • Cable trays and electrical conduits must be independently supported and braced • Suspended ceilings will be subject to special inspection • Perimeter support wires within 8"

NOTE: Consult your local code professional for information specific to your region. California projects may be governed by DSA and OSHPD.

ADDITIONAL RESOURCES ON SEISMIC CODES AND REQUIREMENTS

Contact TechLine at Armstrong (Monday through Friday – 8:00 a.m. to 5:30 p.m. EST):

- ▶ Phone: 1 877 276 7876
- ▶ Fax: 1-800-572-8324
- ▶ Email: techline@armstrongceilings.com

Visit these code-related websites:

- ▶ **ASTM International:** www.astm.org
- ▶ **National Institute of Building Sciences:** www.nibs.org
- ▶ **FEMA:** www.fema.gov
- ▶ **ICC-ES:** www.icc-es.org
- ▶ **U.S. Geological Survey:** www.usgs.gov

ICC-ES Evaluation Service

ICC-ES does technical evaluations of building products, components, methods, and materials. The evaluation process culminates with the issuance of technical engineering reports that directly address the issue of code compliance. These reports are extremely useful because regulatory agencies use evaluation reports to help determine code compliance and enforce building regulations; and manufacturers use reports as evidence that their products meet code requirements and warrant regulatory approval. This is especially important if the products are new and innovative.

ICC-ES employs a large staff of professionally licensed architects and civil, structural, mechanical, and fire protection engineers. The members of the ICC-ES technical staff are experts in the application of model codes, and also have access to historical information relating to product evaluation. When developing acceptance criteria, ICC-ES routinely seeks input from building industry experts through a process of open public hearings. These hearings are conducted by an independent committee composed of code officials who actually enforce building regulations.

IAPMO Evaluation Service

IAPMO performs technical evaluations of building products, components, methods, and materials. The evaluation process culminates with the issuance of technical engineering reports that directly address the issue of code compliance. These reports are extremely useful because regulatory agencies use evaluation reports to help determine code compliance and enforce building regulations; and manufacturers use reports as evidence that their products meet code requirements and warrant regulatory approval. This is especially important if the products are new and innovative.

The Uniform Evaluation Report helps the code official know the product has undergone the highest levels of third-party scrutiny available. It also documents that the product undergoes IAPMO's continuous compliance inspection program. All the relevant code compliance information is summarized in the report to assist you in selection, and the code official in verifying code acceptability. Although an evaluation report is not a guarantee, those products without such a report risk having to supply pertinent information to each code official.

ARMSTRONG CEILINGS SEISMIC TESTED SYSTEMS

Alternative Materials and Construction Methods

Armstrong Ceilings has tested many items that have not been submitted to the Engineering Evaluation Report process. We can provide white papers and test reports to document seismic performance; however, many of these products do not have clear code requirements:

13.2.5 Testing Alternative for Seismic Capacity Determination. As an alternative to the analytical requirements of Sections 13.2 through 13.6, testing shall be deemed as an acceptable method to determine the seismic capacity of components and their supports and attachments. Seismic qualification by testing based upon a nationally recognized testing standard procedure, such as ICC-ES AC 156, acceptable to the authority having jurisdiction shall be deemed to satisfy the design and evaluation requirements provided that the substantiated seismic capacities equal or exceed the seismic demands determined in accordance with Sections 13.3.1 and 13.3.2.

13.2.6 Experience Data Alternative for Seismic Capacity Determination. As an alternative to the analytical requirements of Section 13.2 through 13.6, use of experience data shall be deemed as an acceptable method to determine the seismic capacity of components and their supports and attachments. Seismic qualification by experience data based upon nationally recognized procedures acceptable to the authority having jurisdiction shall be deemed to satisfy the design and evaluation requirements provided that the substantiated seismic capacities equal or exceed the seismic demands determined in accordance with Section 13.3.1 and 13.3.2.”

Source: ASCE 7, Chapter 13

In some cases, there are no clear industry code requirements or acceptance criteria such as:

- ▶ **Ceilings that do not run wall-to-wall**
- ▶ **Indirect hung ceilings**

As a result, seismic performance and engineering information cannot be included in an ESR report.

In light of this, Armstrong Ceilings has conducted rigorous testing at the State University of New York, University at Buffalo, to demonstrate seismic performance. Test result summaries can be provided to code officials in the form of white papers.

For example: In 2004, Armstrong Ceilings led the industry with seismic testing documentation summaries and test protocols for our Seismic Rx® solution. This information set the industry standard and drove the issuance of ESR-1308 in 2006.

Products Not Covered by a Report

Providing a valid report to a code official does represent the “gold standard” for installations. A report represents the safest, least risky method for selecting a seismic ceiling solution. Armstrong Ceilings has tested a number of products that do not appear in a report because these products do not have clear code requirements. We will provide performance criteria via white paper or test report based on large-scale seismic shake table test results from an IAS accredited test facility (State University of New York, University at Buffalo). A white paper or test report can be obtained by calling TechLine at 1 877 276-7876.

When requesting a white paper or test report, you'll be asked to provide the following project information:

- ▶ **Project Name**
- ▶ **Location**
- ▶ **Product**
- ▶ **Customer Contact**
- ▶ **Design Professional Contact**

State University of New York, University at Buffalo

Armstrong Ceilings has partnered with the State University of New York, University at Buffalo, to test our products for seismic performance. These tests are performed at the Structural Engineering and Earthquake Simulation Laboratory (SEESL) located in Ketter Hall. SEESL is a key equipment site in a nationwide earthquake engineering collaborator – the National Science Foundation’s George E. Brown, Jr. Network for Earthquake Engineering Simulation (NEES). This network allows earthquake engineers and students from different institutions to share resources, collaborate on testing, and exploit new computational technologies.



Exterior photo of UB's Structural Engineering and Earthquake Simulation Laboratory (SEESL)



SEESL's twin relocatable shake tables

THE SEESL FACILITY HAS THE FOLLOWING CAPABILITIES:

- Three earthquake simulators known as shake tables
- A two-story biaxial shaking table system used as non-structural component simulator
- A 175 m² strong reaction wall for reactions to horizontal loading devices (actuators) for large-scale testing
- A 340 m² strong testing floor for vertical reactions and tie downs of large-scale models
- A biaxial laminar box for 1.0g soil testing
- Reconfigurable assemblies of static and dynamic servo-controlled actuators with advanced control systems (STS, Flextest, etc.)
- A high-performance hydraulic power supply with flow exceeding 6,000 liters per minute (1,600 gallons per minute)
- High-speed wideband local and wide area gigabit networks interfaced and supported by NEESit services
- Tele-presence & tele-operations capabilities for local and wide area collaborations in real time
- Advanced dynamic, pseudo-dynamic, and static testing capabilities including a generic advanced procedure real time dynamic hybrid testing (RTDHT)

Additional information can be found by visiting nees.buffalo.edu

Full-scale Seismic Tested

Armstrong Ceilings has partnered with the State University of New York, University at Buffalo, to test both standard and non-standard ceiling systems for seismic performance. Armstrong Ceilings submitted the following:

- ▶ **Dynamic Testing – Seismic Qualification by Shake Table Testing**
- ▶ **Static Testing – Vertical, Compression, and Tension Loads**

IBC code allows alternative designs if tests are conducted and evidence of compliance is submitted. Thus, code officials may approve other installation designs based upon the following:

Section 104.11 Alternative materials, design and methods of construction and equipment.

The provisions of this code are not intended to prevent the installation of any material or to prohibit any design or method of construction not specifically prescribed by this code, provided that any such alternative has been approved. An alternative material, design, or method of construction shall be approved where the building official finds that the proposed alternative meets all of the following:

1. The alternative material, design, or method of construction satisfactory and complies with the intent of the provisions of this code.
2. The material, method, or work offered is, for the purpose intended, not less than the equivalent of that prescribed in this code as it pertains to the following:

2.1. Quality 2.2. Strength 2.3. Effectiveness 2.4. Fire Resistance 2.5. Durability 2.6. Strength

Where the alternative material, design, or method of construction is not approved, the building official shall respond in writing, stating the reasons why the alternative was not approved.

Section 104.11.1 Research reports.

Supporting data, where necessary, to assist in the approval of materials or assemblies not specifically provided for in this code, shall consist of valid research reports from approved sources.

Section 104.11.2 Tests

Whenever there is insufficient evidence of compliance with the provisions of this code, or evidence that a material or method does not conform to the requirements of this code, or in order to substantiate claims for alternative materials or methods, the building official shall have the authority to require tests as evidence of compliance to be made at no expense to the jurisdiction. Test methods shall be as specified in this code or by other recognized test standards. In the absence of recognized and accepted test methods, the building official shall approve the testing procedures. Tests shall be performed by an approved agency. Reports of such tests shall be retained by the building official for the period required for retention of public records.

Source: International Building Code 2021

Product	Installation Detail	Product	Installation Detail
Axiom® Building Perimeters	Perimeter Pocket with Horizontal Diffuser Perimeter Pocket with Vertical Diffuser	Seismic	Category C Installation per Code Category D, E & F Installation per Code Seismic Corridor with 8" Gusset Seismic Corridor with 12" Gusset Seismic Joint Clip Main Beam (SJMR15) Fully Loaded Seismic Joint Clip Main Beam (SJMR9) Fully Loaded Seismic Joint Main Beam Splice Seismic Separation Joint on Prelude XL Seismic Separation Joint on Suprafine® XL STAC – Single Tee Adapter Clip
Canopies	Capz™ MetalWorks™ MetalWorks™ Wings Optima® Canopies SoundScapes® Canopies WoodWorks®	Seismic Rx®	BERC2 45-degrees to the Wall on Prelude® XL BERC2 Fully Loaded on Prelude® XL BERC2 on 7897 Shadow Molding with Ultima® Vector Panels BERC2 on Interlude® XL HRC BERC2 on Interlude XL HRC with Lights & Sprinklers BERC2 on Silhouette® XL with Diffusers & Sprinklers BERC2 with Prelude® XL Intermediate-duty BERC2 with Suprafine® XL ALBERC2 Prelude XL – Alternate Category C
Clouds	6' x 6', 12' x 12', and 14' x 14' Formations™ 12" Axiom® Floating 2-sides with Prelude® XL ID 12" Axiom Floating Cloud with Prelude XL ID 6" Axiom Floating 2-sides with Prelude XL ID 6" Axiom Floating Cloud with Prelude XL ID 16" Axiom® Trim Infusions® Shapes Formations Curves Serpentina® Classic Serpentina® Vault Serpentina® Waves™ SoundScapes® Blades™ SoundScapes® Shapes	Standard T-Bar Suspension System	Metaphors® Optima® Radial Ceiling Optima® Vector Optima Vector 24" x 96" Planks Optima Vector 48" x 48" Panels Prelude® XL Fire Rated Prelude® XL Intermediate-duty Prelude® XL to Black Iron NYC Prelude XL Max Shiplap Full Room Silhouette® XL with Shadow Molding Sloped Ceiling Suprafine® XL Installation per Code TechZone™ Ceiling Systems Ultima® Beveled Tegular Ultima Vector
Corridors	Acoustical Locking Angle Mold with 8" Gusset Acoustical Locking Angle Mold with 12" Gusset Acoustical Locking Angle Mold with Fiberglass Panels Acoustical Locking Angle Mold with Mineral Fiber Panels ShortSpan® Corridor System with Gusset SingleSpan™ Acoustical Corridor Suspension System	Tectum®	Blades and Baffles Clouds Create!™ DesignArt™ – Direct-Attach DesignArt™ – Tegular Finale™ Finale™ PB High NRC Lay-in Tegular Shapes
Drywall Systems	6' DGS Tees Drywall Grid System QuikStix™ Locking Pocket Main ShortSpan 14' ShortSpan 6'	WoodWorks®	Access™ Canopies Grille Linear Curved Linear Flat Tegular on Prelude XL Vector on Prelude XL
FeltWorks®	Blades	Other	Capz
MetalWorks™	Blades – Classics Clip-on DH700 Faceted Tegular and Vector® Fastrack 3", 6", and 12" Flush Tegular on Prelude XL Linear Curved and Flat Open Cell 4" and 8" Planks RH200 RH200 Cantilevered Curved RH215 Curved RH215 Square Tegular on Prelude XL Standard Planks Tartan 3" Tartan 6" with Mega Panels Tartan 6" with Planks Torsion Spring Vector® on Prelude® 15/16" suspension system Wings		

THE ARMSTRONG® SEISMIC RX® SUSPENSION SYSTEM (ESR-1308)

Seismic Rx

ICC-ES recognizes the Armstrong® Seismic Rx Suspension System as a code-compliant solution (ESR-1308). This evaluation and confirmation by ICC-ES provides evidence supporting the Armstrong Seismic Rx Suspension System as a code-compliant alternative to IBC requirements.

Benefits of Seismic Rx

Seismic Rx has an ICC-ES evaluation which allows the utilization of 7/8" wall molding for ceiling installations in IBC Categories C, D, E, and F. The ICC-ES allows you to meet seismic code without the risk of delaying your construction schedule.



Seismic Rx allows you to eliminate unsightly 2" wall angle in Category D, E, F seismic-compliant installations.

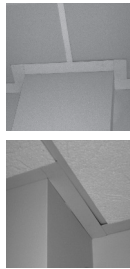

2" wall angles are prone to the following problems:

- ▶ **Difficult to keep tight to wall**
- ▶ **Difficult to install corners**
- ▶ **Prone to twisting and warping**

In IBC Category C – Armstrong Seismic Rx benefits include:

- Easier to square the system by cutting tight to adjoining walls
- Tighter, more secure installation
- Eliminates stabilizer bars

IBC Category C Armstrong Seismic Rx Suspension System ICC Report ESR-1308

- Minimum 7/8" wall molding
- Suspension system may be cut tight on two adjoining walls
- Minimum 3/8" clearance on two unattached walls
- BERG or BERG2 on all perimeter main beam and cross tee ends

IBC Installation Requirements

- Minimum 7/8" wall molding
- Suspension system must not be attached to the wall molding
- Minimum 3/8" clearance on all sides
- Minimum 3/8" overlap of suspension system on the wall molding
- Ends of main beams and cross tees must be tied together to prevent spreading

In IBC Category D, E, and F – Armstrong Seismic Rx benefits include:

- Reduces material costs by using 7/8" molding
- Eliminates stabilizer bars
- Eliminates installation hassles associated with 2" wall molding

From ASCE7-16, Chapter 13: 13.5.6.2.2 Seismic Design Categories D-F

Acoustical tile or lay-in panel ceilings in structures assigned to Seismic Design Categories D, E, and F shall be designed and installed in accordance with ASTM C635, ASTM C636, and ASTM E580. Section 5 – Seismic Design Categories D, E, and F as modified by this section. Acoustical lay-in panel ceilings shall also comply with the following:

- a. The width of the perimeter supporting closure angle or channel shall be not less than 2.0" (50mm) unless qualified perimeter supporting clips are used. Closure angles or channels shall be screwed or otherwise positively attached to wall studs or other supporting structures. Perimeter supporting clips shall be qualified in accordance with approved test criteria per Section 13.2.5. Perimeter supporting clips shall be attached to the supporting closure angle or channel with a minimum of two screws per clip and shall be installed around the entire ceiling perimeter. In each orthogonal horizontal direction, one end of the ceiling shall be attached to the closure angle, channel, or perimeter supporting clip. The other end of the ceiling grid in each horizontal direction shall have a minimum 0.75" (19mm) clearance from the wall and shall rest upon and be free to slide on a closure angle, channel, or perimeter supporting clip.

IBC Category	Armstrong Seismic Rx Suspension System ICC Report ESR-1308
D, E, F	<ul style="list-style-type: none"> • Minimum 7/8" wall molding • Suspension system must be attached on two adjacent walls – opposite walls require BERC2 with 3/4" clearance • BERC2 maintains main beam and cross tee spacing; no other components required • Heavy-duty systems as identified in ICC-ESR-1308 (refer to Suspension Systems listed on page 8)

IBC Installation Requirements
<ul style="list-style-type: none"> • Minimum 2" wall molding • Suspension system must be attached to two adjacent walls – opposite walls must have a 3/4" clearance • Ends of main beams and cross tees must be tied together to prevent spreading • Heavy-duty suspension system

ESR-1308 List Specific Armstrong Components and Methods of Installation

The performance of the Armstrong Seismic Rx® Suspension System is based on a specific combination of components and method of installation. Other manufacturers' components and installation methods were not tested and are not covered in ESR-1308. Substitution of other components puts the system at risk and is not allowed by the ESR report.

The following ceiling and suspension systems are included in ESR-1308. These systems were tested to withstand seismic forces in all IBC categories. All ceilings have test details and summaries to support the demonstrated performance and integrity of the system.

FAMILY NAME	DESCRIPTION
PRELUDE® XL®	15/16" Exposed Tee System, Fire Guard™ 15/16" Exposed Tee System, 15/16" Environmental Tee System
PRELUDE XL MAX™	15/16" Exposed Tee System
SILHOUETTE® XL	1/4" Reveal 9/16" Bolt-Slot System, 1/8" Reveal 9/16" Bolt-Slot System
SUPRAFINE® XL	9/16" Exposed Tee System, Fire Guard 9/16" Exposed Tee System
INTERLUDE® XL HRC	9/16" Dimensional Tee System
CLEAN ROOM™	1-1/2" Clean Room Suspension System. 15/16" Clean Room Suspension System*

* ASTM C635 (heavy-duty) main beam classification

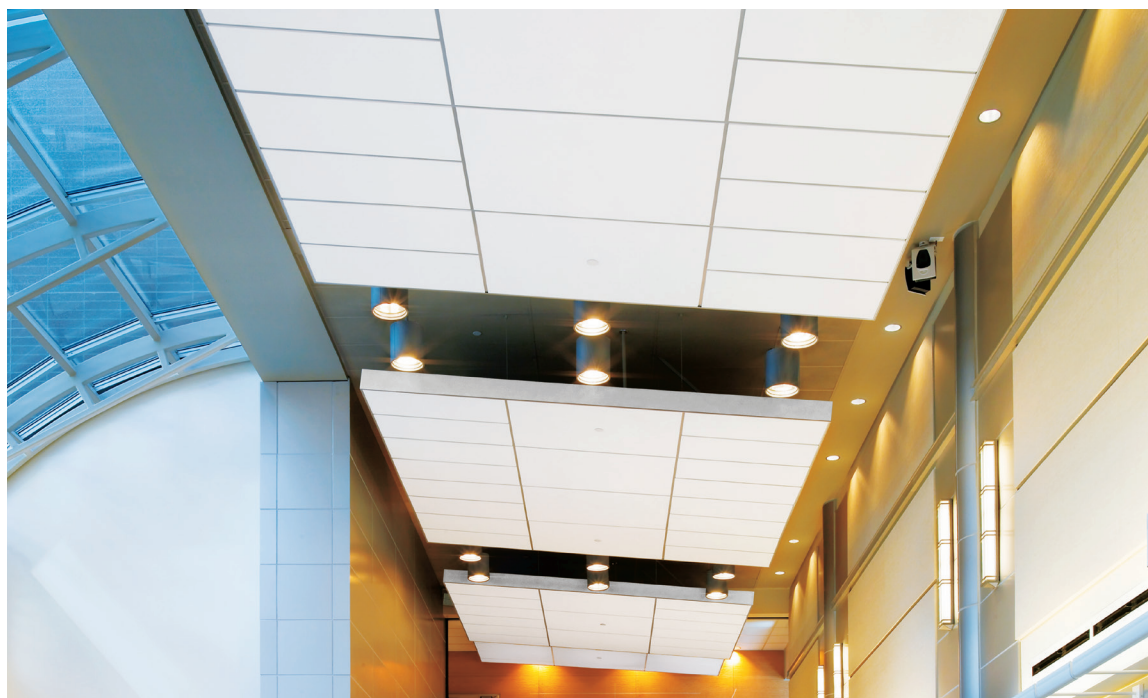

▲ Optima® 24" x 48" and 48" x 48" panels with Suprafine® XL® 9/16" and 8" Axiom Classic; University of Utah Hospital, West Pavilion, Salt Lake City, UT

SEISMIC RX® APPROACHES TO CATEGORY C INSTALLATIONS

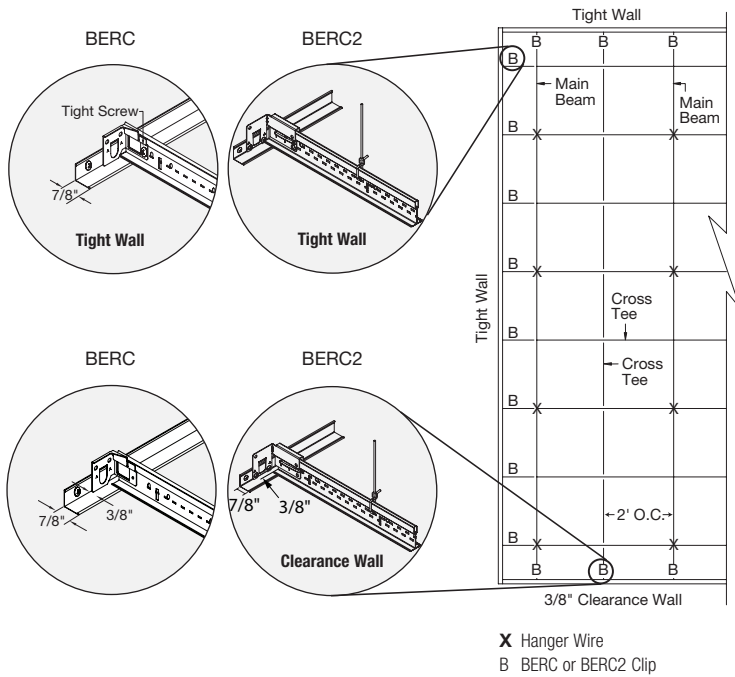

Seismic Rx Code Compliant Solutions and Benefits (ESR-1308)

- Meets code requirements
- Easy to square the system
- Eliminates stabilizer bars
- Better access to the plenum
- Narrow, sleek aesthetic with standard 7/8" molding
- Suspension system can be tight on two adjoining walls – can use the BERC or BERC2
- Intermediate-duty suspension system

IBC APPROACH TO CATEGORY C INSTALLATIONS

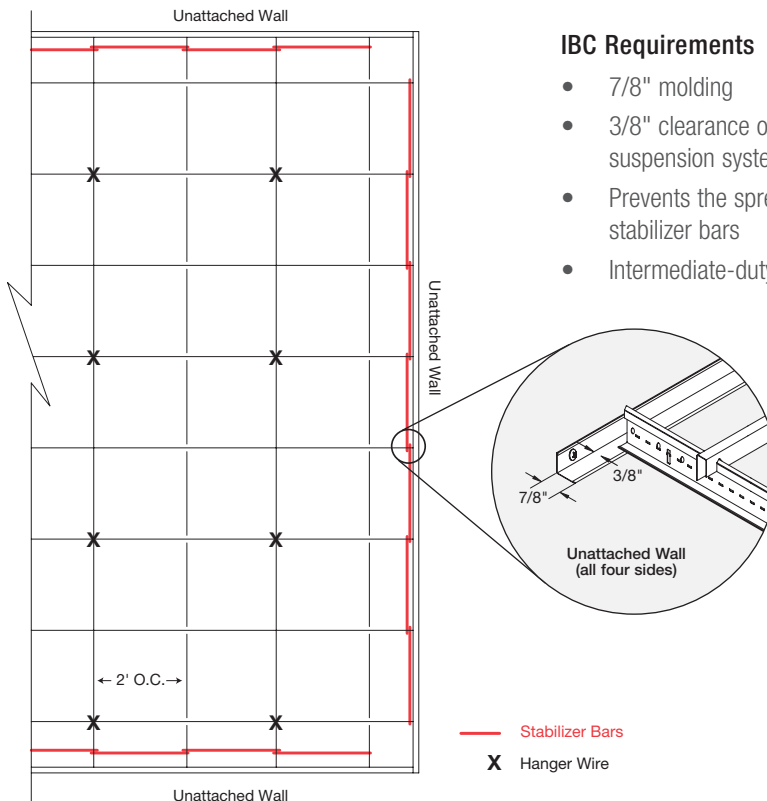

IBC Requirements

- 7/8" molding
- 3/8" clearance on all sides; 3/8" overlap of the suspension system on the wall molding
- Prevents the spread of main beams/cross tees with stabilizer bars
- Intermediate-duty suspension system

SEISMIC RX® APPROACHES TO CATEGORY D, E, AND F INSTALLATIONS

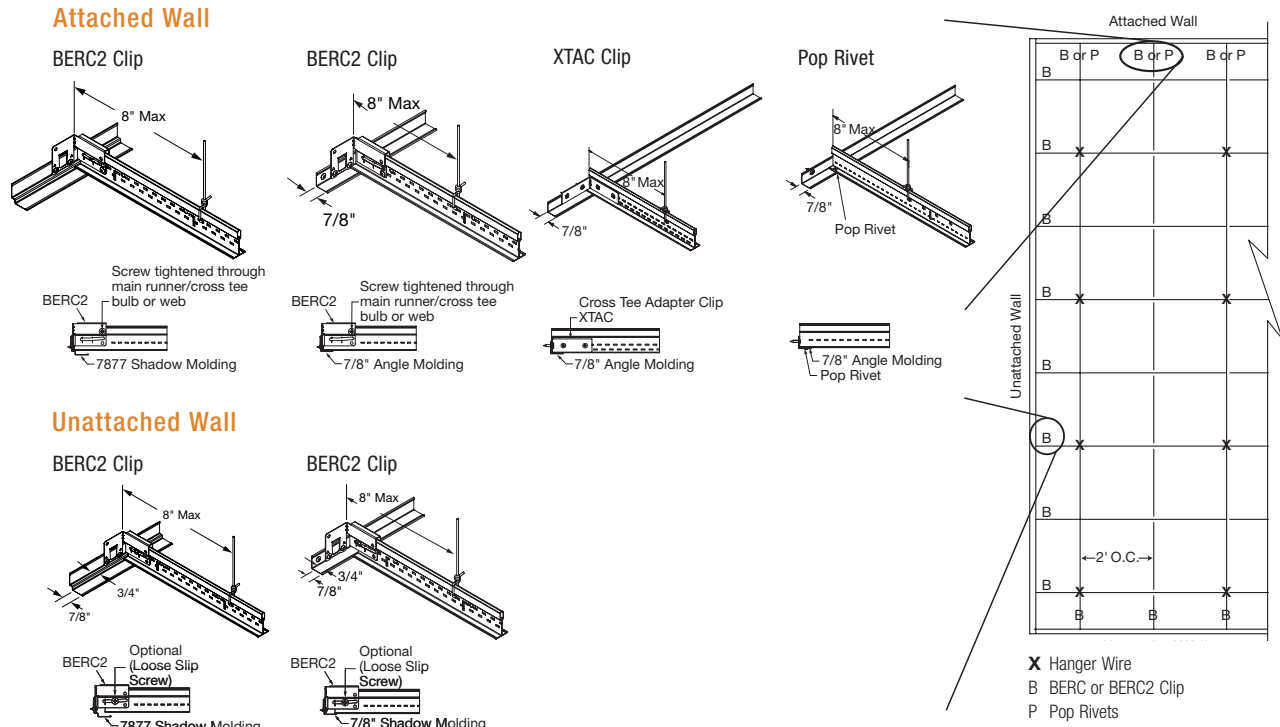

Seismic Rx Code Compliant Solutions and Benefits (ESR-1308)

- Narrow, sleek aesthetic with standard 7/8" molding
- Eliminates installation and aesthetic problems associated with 2" wall molding
- Lower cost solution
- Better access to the plenum
- Eliminates stabilizer bars
- Eliminates visible pop rivets through the wall angle
- More profiles from which to choose
- Perimeter support wires within 8"
- Attached suspension system on two adjacent walls with the BERC2, ALBERC2, or pop rivets
- BERC2 or ALBERC2 clip with 3/4" clearance on unattached walls

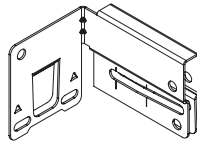

IBC APPROACH TO CATEGORY D, E, AND F INSTALLATIONS

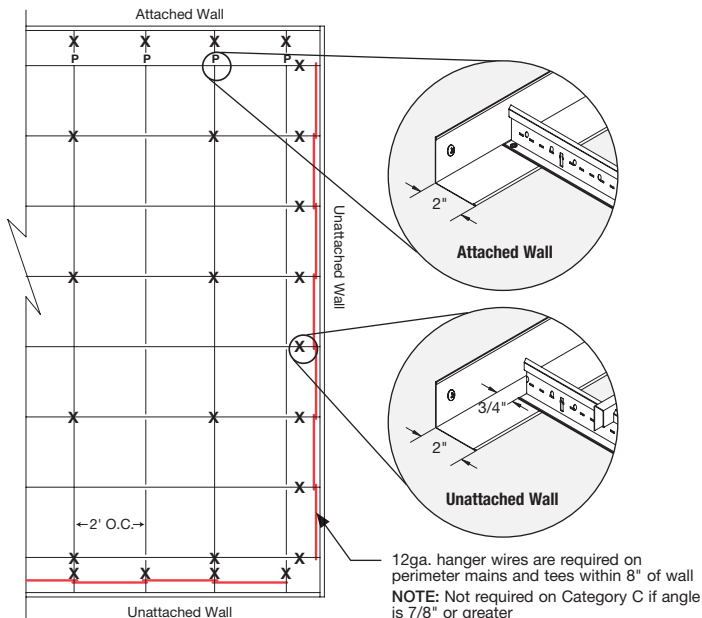

IBC Requirements

- 2" molding
- Attached suspension system on two adjacent walls with pop rivets, screws, or other means
- 3/4" clearance at perimeter on unattached walls and stabilizer bars to prevent the spread of main beams and cross tees
- Heavy-duty suspension system

- X Hanger Wire
- P Pop Rivets
- Stabilizer Bars

PREVENTING BORDER PANELS FROM FALLING – INSTALLATION TIP

The Case for Perimeter Wires

In full-scale seismic test evaluations for areas subject to severe seismic motion, the common cause of system failure came from damage to cross tee end connectors (Armstrong Ceilings and competitive systems). Damage occurred in one of two ways:

- ▶ Connector clip bends
- ▶ Base metal bends

When this damage occurs, it allows unbraced sections of the ceiling to move up to 3/8" at each connection. The cumulative effect of damage at the cross tee connections may move the ceiling more than 2".

Without perimeter support wires, test results demonstrate that the load of the ceiling may cause the main beams and cross tees to move beyond the 2" wall molding and drop out. System failure at the perimeter does not conform to the requirements of the code.

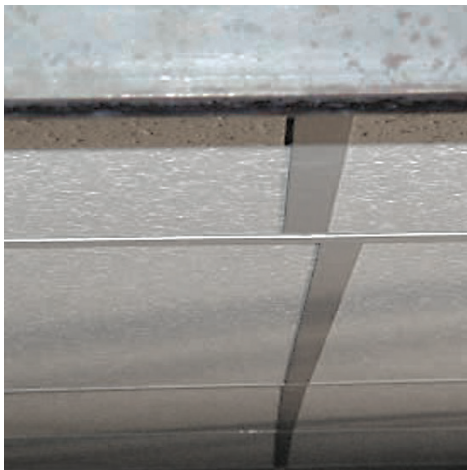

Damage at cross tee connections allows ceiling movement.



Unsupported cross tees allow panels to drop out.

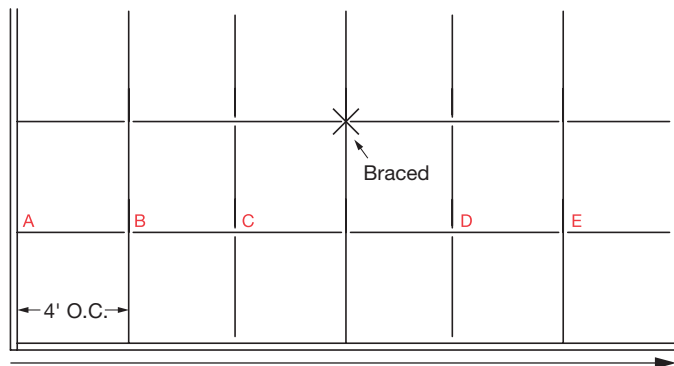

||

Potential Movement

$$\frac{3}{4}'' + \frac{3}{8}'' + \frac{3}{8}'' + \frac{3}{8}'' + \frac{3}{8}'' = 2\text{-}1/4''$$

SEISMIC SEPARATION JOINTS

Purpose of Separation Joints

ASCE 7 Section 13.5.6.2.2 mandates that ceiling areas greater than 2,500 SF must have seismic separation joints, closure angles, and horizontal restraints. This means 2" molding, perimeter spacer bars – and if the area is greater than 1,000 SF, lateral force bracing. It is thought that these measures will prevent the accumulated forces from overpowering an individual suspension system connection. This method of failure was observed after some strong California quakes in the 1980s.

The code does not describe how to construct the separation joint. Initially, we responded to inquiries by providing an expansion joint detail fabricated from steel moldings. This type of joint is widely accepted because it is familiar to inspectors and because the width of the separation can be set to match whatever the project designer requires. However, many designers find this method objectionable:

- ▶ Traditional field-fabricated expansion joint details are very noticeable on the ceiling plane
- ▶ The system is not very rigid and the suspension system can move “off module”

Seismic Joint Clips for Main Beams and Cross Tees

Armstrong Ceilings has done full-scale testing which confirms that a ceiling fitted with our Seismic Joint Clip for Main Beams (SJMR) and Seismic Joint Clip for Cross Tees (SJCG & SCJSI) perform as well as a field-fabricated separation joint.

Additional benefits to these seismic-tested separation joints are:

Seismic Joint Clip – Main Beam (SJMR)

- Allows 3/4" of main beam travel
- Gives architects and designers a clean look (not visible from the floor)
- Saves contractors time with a reliable installation method
- Easily installs in minutes at main beam splice
- Maintains integrity of the ceiling module, unlike field-assembled alternatives
- Allows for full acoustical panel at the joint
- Easier to keep the ceiling system square

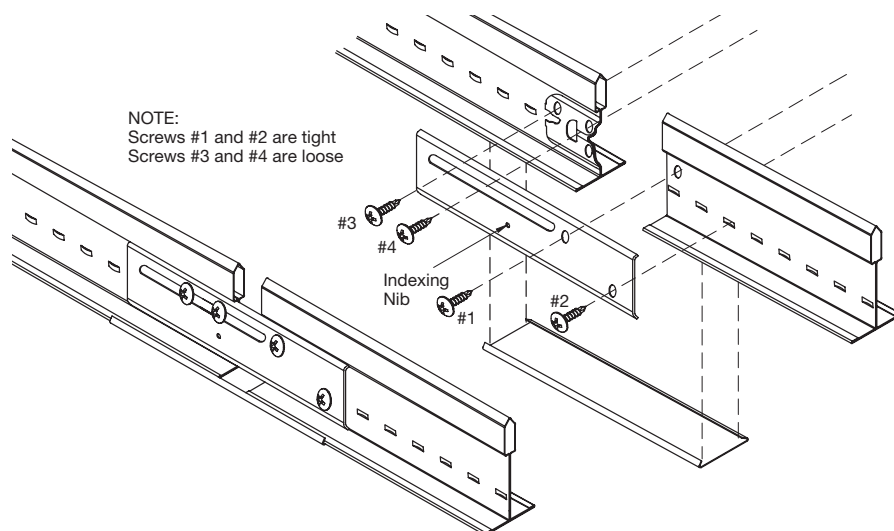

Seismic Joint Clip – Cross Tee (SJCG & SJCSI)

- Gives architects and designers a clean look (not visible from the floor)
- Saves contractors time with a reliable installation method
- Installs in minutes, no need to cut the face of the suspension system to install clip
- Eliminates the need for additional hanger wires
- Maintains integrity of the ceiling module, unlike field-assembled alternatives
- Allows the use of full-size panels
- Works with our PeakForm® suspension system (Suprafine®, Prelude®) and square bulb suspension systems (Silhouette® and Interlude® XL® HRC)

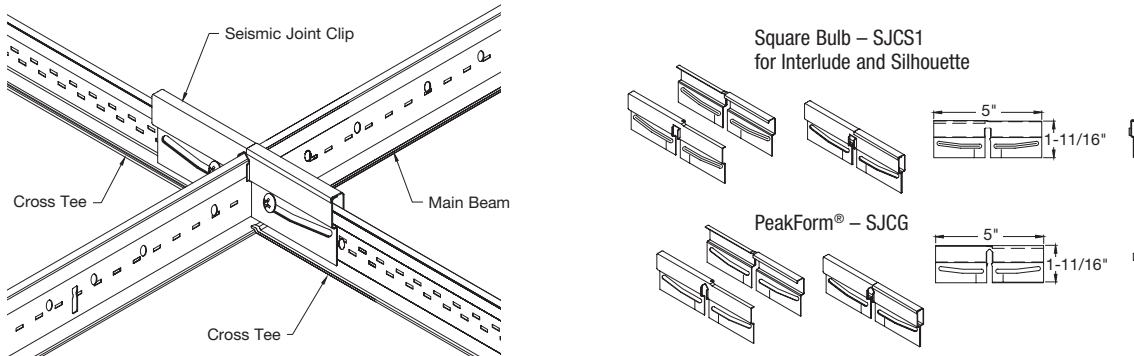

SEPARATION JOINT LAYOUT DETAILS

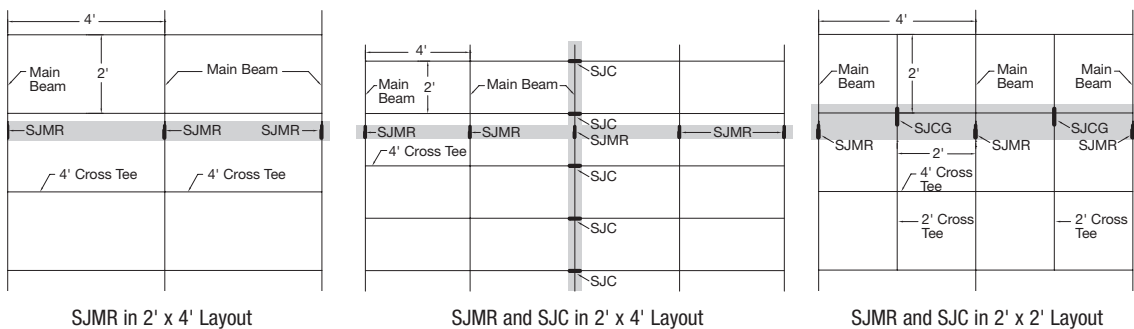

STAC – SINGLE TEE ADAPTER CLIP

The Single Tee Adapter Clip (STAC) is used to create code compliant, off-module cross tee connections on Armstrong Ceilings suspension systems where a cross tee intersects with a main beam and is not locked into place with another cross tee. This type of “off-module” intersection frequently occurs with running bond and ashlar suspension system layouts as shown below.

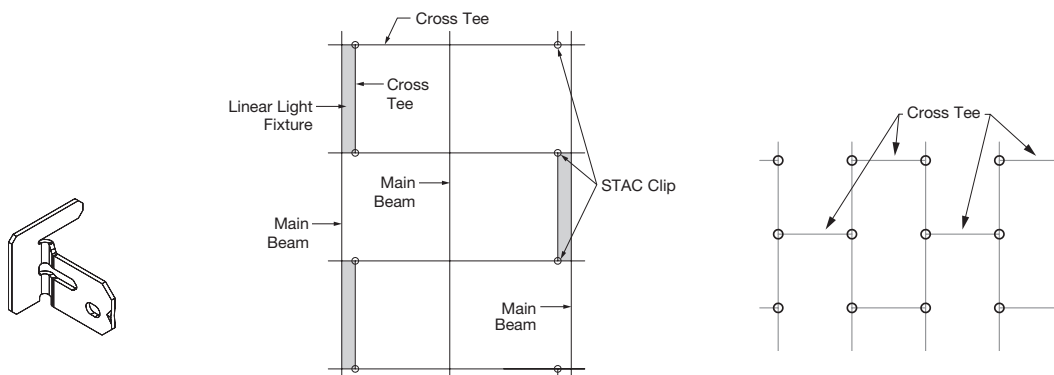

The STAC Clip:

- Provides code compliant (non-seismic and Seismic Design Categories C and D, E, F) “off-module” main beam to cross tee connections
- Improves the squareness of the installed suspension system and prevents twisting of main beams
- Allows panel accessibility, no interference from screws, etc.
- Meets ASTM E580 compliant pullout strength:
 - Seismic Design Category C requirement is 60 lbs
 - Seismic Design Categories D, E, F requirement is 180 lbs

Armstrong Ceilings Suspension Systems That Can Utilize the STAC Clip Include:

- | | |
|--------------------------|---------------------------|
| ▶ Prelude® XL®/ML | ▶ Silhouette® 1/4" XL® * |
| ▶ Suprafine® XL®/ML | ▶ Interlude® XL® HRC |
| ▶ Silhouette® 1/8" XL® * | ▶ Armstrong® Drywall Grid |

* Silhouette XL suspension intersection will result in a non-mitered visual at STAC location

BRACING AND RESTRAINT FOR SEISMIC INSTALLATIONS

Difference Between Bracing and Restraint

Attachment to the wall is considered restraint. Bracing is a form of restraint (compression post and wires).

Typical seismic bracing for a wall-to-wall ceiling consists of clusters of four 12-gauge wires arrayed 90° from one another and attached to the main beam within 2" of a cross tee intersection. These wires are to be angled no more than 45° from the plane of the ceiling. The compression post is attached to the suspension system at the cluster of wires and extends to the overhead structure (see Figure 1).

The compression post needs to be engineered for the application and the longer its length the more substantial it must be. Typical post materials are EMT conduit or steel stud (see Figure 2).

The code also allows for the use of rigid bracing. The advantage here is that when a rigid member is used in place of wires, it can handle loads in two directions (push and/or pull) so only two diagonals and one vertical are needed at each location (see Figure 3).

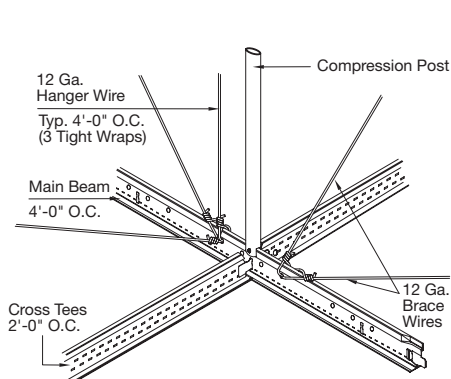

Figure 1

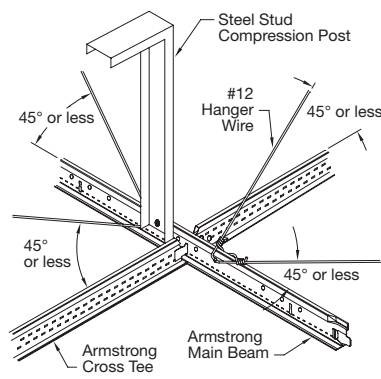

Figure 2

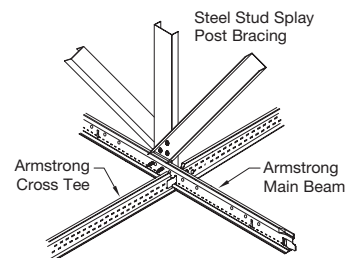

Figure 3

Typical wall-to-wall ceiling restraint is achieved by proximity or attachment to the perimeter angles which are fixed to the walls. Seismic Design Category C allows some movement but limits are established by setting the required clearance at 3/8". Seismic Design Categories D, E, and F require the ceiling suspension system to be fixed to the wall molding on two adjacent walls. This attachment to the molding is the first element of restraint. As the ceiling area gets larger and the mass (or weight) of the ceiling increases, additional restraint must be applied in the form of "lateral force bracing."

CLOUDS AND CANOPIES

Installing Clouds

Armstrong Ceilings defines a cloud as a ceiling that is not connected to a wall on any side.

Armstrong Ceilings defines a canopy as a single, unique architectural element which is independently suspended from the building structure.

ASCE 7 allows architectural components supported by chains or otherwise suspended from the structure to be exempt from bracing so long as they meet all of the following criteria:

- ▶ **The design load for such items shall be equal to 1.4 times the operating weight acting down with a simultaneous horizontal load equal to 1.4 times the operating weight. The horizontal load shall be applied in the direction that results in the most critical loading for design.**
- ▶ **The functional and physical interrelationship of components, their supports, and their effect on each other shall be considered so that the failure of an essential or non-essential architectural, mechanical, or electrical component shall not cause the failure of an essential architectural, mechanical, or electrical component.**
- ▶ **The connection to the structure shall allow a 360° range of motion in the horizontal plane.**

ASCE 7 Design Manual, Section 13 states that the design of architectural components, and their supports, is required to meet minimum values as calculated in Section 13.3.1 for seismic force and Section 13.3.2 for lateral displacement. Ceilings are a line item on the chart associated with these calculations. Unless specifically exempted by the local authority, it should be assumed that a cloud (architectural component), comprised of a suspension system, and panels must be restrained. Part of the formula used in these calculations takes seismic design category into consideration, so the minimum force values will go down or up as the seismic risk changes.

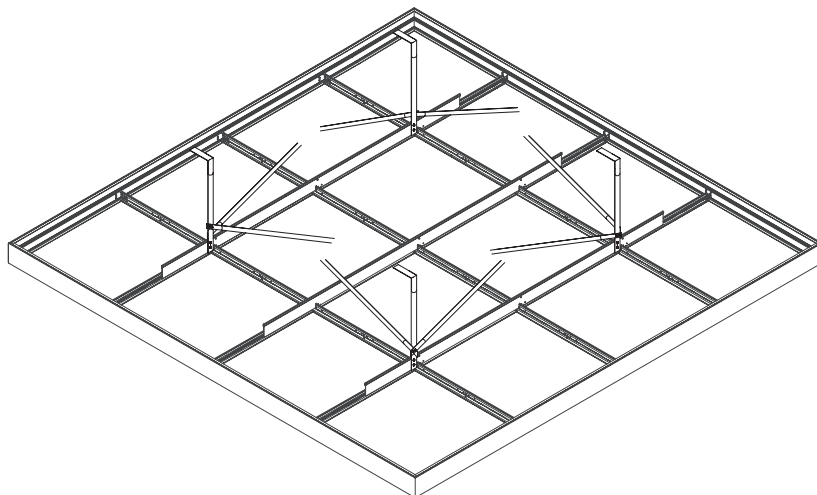

Cloud ceilings installed in Seismic Design Categories A, B, and C do not require lateral force bracing. In these areas, ceilings are designed to allow movement and are designed to resist the minimal seismic forces without causing major damage. The addition of lateral force bracing works against these designs. Systems that are to be installed in Seismic Design categories D, E, and F must be lateral force braced if they are of the size or mass to cause damage to an essential architectural, mechanical, or electrical component. Examples of essential components are sprinkler systems, fire or smoke sensors, and emergency lighting systems.

During our testing of cloud ceilings, we switched from splayed wires to rigid bracing. The primary reason is not to have wires extending beyond the edges of the cloud. The installation included a vertical post and two diagonals at the suspension system intersection closest to each corner of the cloud and then not more than 12 feet in each direction. We have successfully used 1/2" diameter EMT for post and diagonals on all such tests. The EMT ends are flattened and bent to facilitate attachment to the structure and the suspension system. Install the post first, and then connect the diagonals to the lower end of the strut just above the suspension system bulb.

Restraint for a cloud is diagonal bracing to the structure and since clouds are not attached to two walls, they must have restraints. In addition to building code requirements, there is a particular installation benefit for a contractor to restrain a ceiling that does not run wall-to-wall. A restrained ceiling is easier to keep straight and square. Some contractors will initially opt to skip this step in an attempt to save money. However, it is not advisable to do so because rework to fix alignment issues can add more labor costs than if the bracing would have been done at the onset. Typical restraint for a floating ceiling takes the form of rigid diagonal braces that extend from the suspension system members to the overhead structure. Sufficient restraint points must be used to meet the force values required by the code and to prevent movement in all directions. Additionally, the strength of the bracing members also must be matched to the anticipated applied forces. In areas subject to light seismic activity, this restraint often can be achieved with sections of wall molding or main beam.

However, as the seismic forces increase, so must the rigidity or stiffness of the bracing. When the lateral forces match or exceed the weight of the ceiling assembly, or when splay wires are used, a vertical post or strut must be added to prevent the suspension system from lifting. IBC calls for this strut to be added when the project is designated as Seismic Design Category D.

Distance Between a Cloud and Wall or Adjacent Cloud

There is no minimum required as long as clouds are restrained to meet the Seismic Design Category. Our testing has found that rigid bracing at all four corners meets the requirements of Seismic Design Categories D, E, and F for clouds up to 200 SF if:

- ▶ **Bracing varies based on the cloud area, weight, and plenum depth**
- ▶ **The bracing is designed by the project engineer**

Keep in mind that hanger placement is determined by the length of the cantilevered component. It is not a line of sight issue. Also, a cloud will require the same bracing and restraint with or without sprinklers.

Installing Canopies

We have found through testing that it is not practical to restrain an individual canopy. If canopies arranged in a group can be connected together, it is possible to restrain the entire assembly. Wood or metal canopies can be joined by attaching an appropriately sized metal stringer across the back of the grouping and then adding vertical and diagonal bracing to the assembly. SoundScapes® Shapes panels installed on the grouping frame can be restrained by adding vertical and diagonal bracing to the grouping frame assembly.

NOTE: A 1/4" diameter threaded rod would be compatible with the grouping frames used to cluster SoundScapes Shapes panels and it can be turned into the threaded holes located at the corners of the frame embedded into the back of individual SoundScapes Shapes panels. A threaded rod is not mechanically compatible with any of our other canopies.

NOTE: When multiple SoundScapes Shapes panels are installed on grouping frames, they perform like a cloud and should be installed to meet those restraint guidelines.

Distance Between Canopies

As stated earlier, ASCE 7 provides an exception to the restraint requirement for architectural components stated in section 13.5.1. This exception is for “components supported by chains or otherwise suspended from the structure” so long as all of the following criteria are met:

- ▶ **Design load must be equal to 1.4 times the operating weight acting in both vertical and horizontal directions**
- ▶ **The component may not cause damage to an essential building element**
- ▶ **The connections to the structure must allow a 360° range of motion**

The first and third points can be established through design. However, the second could lead a code compliance official to require clear space between the component and an essential element equal to or greater than the length of the supporting chains or cables. Length and the placement of the hanger attachment points have a significant impact on how far the canopy will move. In general terms, the following reactions have been demonstrated through shake table testing:

- ▶ **The closer the hanger attachments are to the edges of the canopy, the lower the motion**
- ▶ **The longer the hangers, the lower the motion**
- ▶ **The heavier the canopy, the lower the motion**

Each of our canopy products is designed with the hardware set in predetermined locations. Each has been tested to determine the maximum amount of movement that can occur and, therefore, the clearance required from essential building elements.



Rigid Bracing

Seismic areas may require rigid bracing for floating elements

ARMSTRONG® DRYWALL GRID SYSTEMS (ESR-1289 AND ESR-2311)

Benefits of ESR-1289

ESR reports are the most recognized reports within the construction industry by code officials for the code compliance and performance of construction materials. ESR-1289 and ESR-2311 represent an ICC code-compliant system for suspended ceiling mounted drywall installations.

The drywall systems components listed in ESR-1289 and ESR-2311 meet ASTM C645 and are UL Fire Rated. Armstrong Drywall Grid offers a labor and cost saving method of meeting seismic code without risk of delaying your construction schedule. Additional benefits of ESR-1289 and ESR-2311 are:

- ▶ **Elimination of the lateral load design requirements (see ESR-1289, Section 4.4.1)**
- ▶ **Recognition and approval of DGS 6' cross tees (XL8965) and 6' spacing of main beams reduces material, hanger wire, and installation time**
- ▶ **UL approval of XL8965 in fire-rated applications**
- ▶ **Recognition of cross tees compatible with Type-F light fixtures – XL8947, XL8947P, XL8925, and XL8918**
- ▶ **Recognition and approval of ShortSpan® pre-engineered solution to support spans up to 8'-6" with no intermediate support**

Seismic Installation Requirements for Drywall Ceilings

The seismic performance of Armstrong Drywall systems Grid is based on a specific combination of components and method of installation. ESR-1289 provides the evidence that these systems were tested to withstand seismic forces in all IBC categories. However, ESR-1289 is intended for use as a guide and is not a substitute for the actual building code. Armstrong Ceilings recommends checking with the authority having jurisdiction for the exact requirements of your municipal building code.

California's Office of Statewide Health Planning and Development (OSHPD) and Division of the State Architect – Structural Safety (DSA-SS) are the two groups most likely to express this view. These groups are responsible for schools, medical facilities, and state owned/leased essential service properties. Before IBC was adopted, these groups used UBC 25-2 supplemented with their own amendments which were contained in a set of Interpretations of Regulations (IR) documents. The IR pertaining to drywall ceilings have not been updated with the adoption of IBC and are no longer referenced on the OSHPD/DSA-SS website. However, OSHPD/DSA does have a set of amendments embedded into the new California Building Code (CBC). Some inspectors are using the old guidelines and others are following the letter of the new code. As a result, some project contractors are being asked to provide 2" molding, perimeter wires, and lateral force bracing. IBC and CBC list requirements for gypsum assemblies in Chapter 25. This document references ASTM C754 as the standard practice for framing installation for these assemblies. While most of C754 speaks to stud and carrying channel/hat track materials, there is a section dedicated to suspension systems.

6.7 Grid Suspension System – Main beams shall be suspended in parallel rows spliced together at their ends.

6.7.1 Hangers for supporting the main beams shall comply with the minimum size and ceiling area specified in Table 6.*

6.7.2 Cross furring members of grid suspension systems shall interlock to the main beams in rows running perpendicular and spaced not to exceed maximums specified in Table 1. Cross furring members along the ceiling perimeter shall be supported by angle or channels attached to the wall.

* C754-08, Section 6.1.1 has been revised to allow for 16 Sq. Ft. spacing of #12 gauge hanger wire for drywall suspended ceiling systems.

No additional requirements are made for seismic installations, suspension systems, or stud and track. The assumption is that the attachment of the drywall panels to the suspension system is capable of transferring the lateral force to the surrounding walls.

ASCE7 specifically addresses suspended drywall grid ceilings in Chapter 13 – Seismic Design Requirements for Nonstructural components. Section 13.5.6 specifies an exception to the requirement for lateral bracing of suspended ceilings if the ceiling is constructed of screw- or nail-attached gypsum board on one level and surrounded by and connected to walls or soffits that are laterally braced to the structure above. Additionally, ASTM has published standard practice C-1858, which specifies the design and installation requirements for these suspended gypsum ceiling grid systems and further details the design and installation requirements that allow for the exclusion of lateral bracing.

Designing the ceiling as a diaphragm is purely an engineering exercise. The engineer must verify that there is sufficient strength in his drywall and suspension system to ensure that the seismic forces can be transferred to the structure. By doing this, the engineer will avoid the need for 2" wall angle, lateral force bracing, and all of the other "ceiling" requirements.

It is our understanding that drywall ceilings are exempt from the requirement of 2" closure angle, lateral force bracing, and perimeter wires. This conclusion is based on review of all of the referenced documents, which are as follows:

- ▶ **Chapter 25 of IBC**
- ▶ **CISCA seismic recommendations**
- ▶ **ASTM E580**
- ▶ **DSA IR Manual**
- ▶ **OSHPD/DSA amendments to IBC**
- ▶ **ASTM 754**
- ▶ **ESR-1289**
- ▶ *** ASTM C-1858**

ADAPTATIONS™ – STANDARD SOLUTIONS, UNIQUE RESULTS

Sloped, Faceted, Staggered, and Layered Ceiling Designs

Armstrong Ceilings offers ceiling and suspension system design guidance for creating unique sloped, faceted, staggered, and layered ceiling designs that address code concerns.

For more information, visit armstrongceilings.com/adaptations.

For available technical white papers, contact TechLine at 1 877 276 7876

▼ Optima® Vector® 24" x 24", 24" x 48", and 48" x 48" panels with Prelude® XL® 15/16" and Axiom® Classic trim; San Francisco International Airport – San Francisco, CA





Optima® Plank, 48" x 96" Ceiling-to-Wall Faceted Transitions with Suprafine® XL® 9/16" with Axiom® Vector® and custom trim; Bayer Interventional – Coon Rapids, MN ▲

TAKE
THE NEXT
STEP



armstrongceilings.com/projectworks

**The power of PROJECTWORKS®
Design and Pre-Construction Service**

Mix and match different sizes, shapes,
colors, and materials to reinvent your ceiling.

Visit our pattern gallery online to see ideas
for your next project.

armstrongceilings.com/patterngallery

Contact your local representative to get a
design started! Not sure who your local rep
is? Visit armstrongceilings.com/findarep

For other questions:

1 877 276 7876

Customer Service Representatives

7:45 a.m. to 5:00 p.m. EST

Monday through Friday

Revit® is a registered trademark of Autodesk, Inc.
All other trademarks used herein are the property of AWI Licensing LLC and/or its affiliates
© 2022 AWI Licensing LLC • Printed in the United States of America

armstrongceilings.com/seismic

