



Construction Efficiencies for General Contractors

Modular Solutions for Common Ceiling Transitions

ABOUT AXIOM TRANSITIONS

- Extruded aluminum provides crisp edge detail
- Consistent, improved aesthetic
- Eliminate stud framing to deck
- Reduce trade coordination (no drywall finishing)
- Meets the most stringent sustainability compliance standards today

AXIOM FIELD TRANSITION

- In place of bulkhead
- Available in 1-1/2", 4", or 6" bulkhead widths

- Transition intersecting ceilings or two types of ceilings
- Acoustical to acoustical transitions only

AXIOM ELEVATION CHANGE TRANSITION

- Straight and curved elevation less than 10"
- Available transition heights of 1", 2", 4", 6", 8", and 10"
- Save up to 40% on installation time
- Acoustical to drywall transitions

 [View Axiom Transitions video](#)

AXIOM[®] TRANSITIONS – STRAIGHT AND CURVED SMOOTH TRANSITIONS

TIME, LABOR, MATERIAL, COST SAVING SOLUTIONS

TRADITIONAL STUD FRAMING

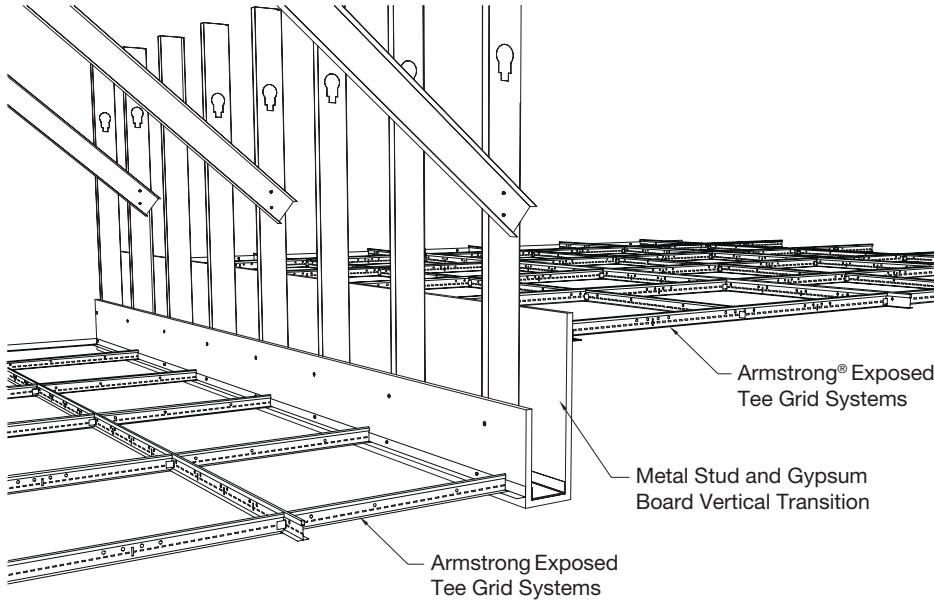

PRE-ENGINEERED SOLUTION

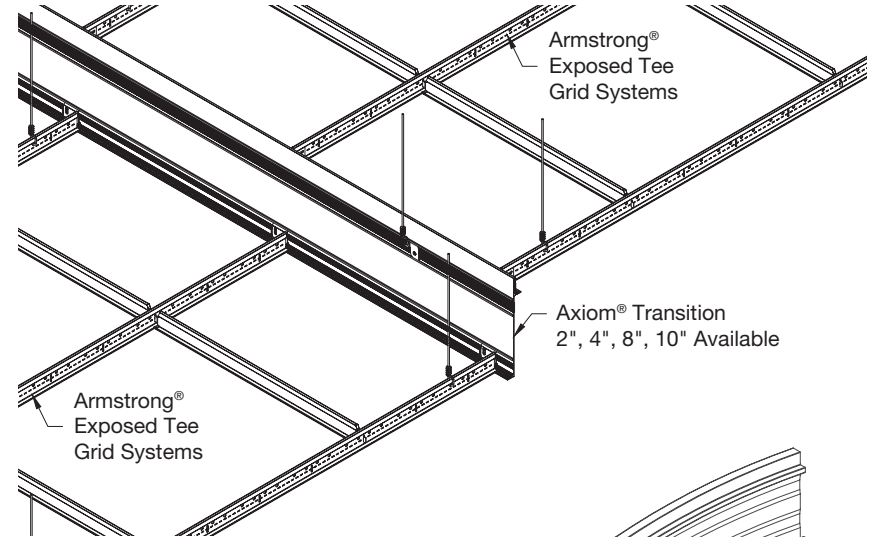

Axiom Elevation Transition
Used in place of a bulkhead
when there is a height transition
of 10" or less

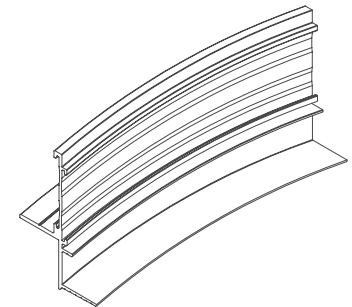

Axiom Transition 1" Curved
for 15/16" Tegular Panels

Contact your GC Experts at: kmackillop@armstrongceilings.com
paluther@armstrongceilings.com

All trademarks used herein are the property of AWI Licensing LLC
and/or its affiliates © 2022 AWI Licensing LLC

BPCS-6890-922

Armstrong®
CEILING SOLUTIONS