



# METALWORKS™ Immix™ Blades

Panelized Torsion Spring  
smooth texture



**TOTAL  
ACOUSTICS™**  
Sound Absorption (NRC)  
+ Sound Blocking (CAC)



**SUSTAIN™**  
High Performance  
Sustainable  
Ceiling Systems



**FAST134**  
Select Items Ship Fast  
[armstrongceilings.com/fast134](http://armstrongceilings.com/fast134)



MetalWorks Immix Blades 1" W x 6" H with 3 blades per panel in Silverlume

CAD/Revit® drawings at:  
[armstrongceilings.com/cadrevit](http://armstrongceilings.com/cadrevit)

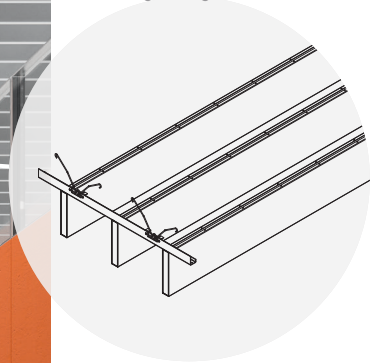

plus capabilities  
to do more



[armstrongceilings.com/capabilities](http://armstrongceilings.com/capabilities)  
See more photos at:  
[armstrongceilings.com/photogallery](http://armstrongceilings.com/photogallery)

An interior panelized torsion spring metal ceiling system in a variety of blade configurations, achieving an accessible, open reveal linear look installed up to twice as fast as individual blade systems.

## KEY SELECTION ATTRIBUTES

- 20 standard 24" x 96" panels with multiple blades in varying heights, widths, and spacing configurations
- Four new Sequels™ pre-coat, wood-look finishes are part of the FAST134 program
- 1" and 2" wide blades with 4", 6", and 8" heights
- 24" x 96" torsion spring panels install up to twice as fast as individual blade systems
- Durable, downward accessible system - quickly open a large area with full panel removal
- Mix and match standard panels with alternating blade heights or widths for a custom look
- Smart design - reveals between blades are equidistant panel-to-panel; Panels have a consistent 1/8" reveal end-to-end
- MetalWorks™ Immix™ panels are part of the Sustain™ portfolio, and meet the most stringent industry sustainability compliance standards today
- CleanAssure™ family of products - includes disinfectable planks, suspension systems, and trim
- 11 panels with 70% or more open area to minimize sprinkler install and material cost, achieving a less cluttered finished ceiling with an open aesthetic
- Select products included in the FAST134 program - ready to ship in 4 weeks or less
- Panels can be field cut; perimeter cut kit and additional end caps are available for a clean, professional finish
- Black acoustical infill panels hide the plenum and achieve up to 0.95 NRC
- Get total noise control and design flexibility with Total Acoustics™ ceiling panels: NRC + CAC = Total Acoustics
- Aluminum blades with exceptional durability - washable, scrubbable, soil-resistant



**new** METALWORKS™ Immix™ Blades

Panelized Torsion Spring  
smooth texture



**Declare.**

LEED® WELL | LBC

16% RECYCLED CONTENT

- energy management
- construction waste mgmt
- regional materials
- design for flexibility
- EPD
- recyclable/producer resp.

Contact TechLine for Green Genie™ information

- recycled content
- sourcing of raw materials
- material ingredient reporting
- low emitting materials
- lighting quality
- acoustics

LOCATION DEPENDENT

WHITE ONLY WITH INFILL PANEL



MetalWorks Immix Blades 2" W x 8" H with 3 blades per panel in Sequels La Jolla Oak

**STANDARD COLORS & FINISHES** Due to printing limitations, shade may vary from actual product.

Painted (Interior only)

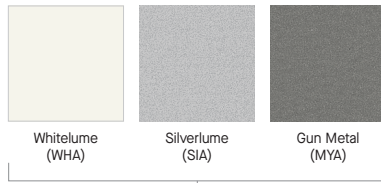

Whitelume (WHA) Silverlume (SIA) Gun Metal (MYA)

These colors are part of the Sustain™ portfolio

**new** Sequels™ Pre-coated Coil, Fast Lead Time



La Jolla Oak (SGLO) New Haven Walnut (SGNW) Cape May Cherry (SQCC) Montauk Driftwood (SQMD)

**CUSTOM COLORS & FINISHES** Due to printing limitations, shade may vary from actual product.

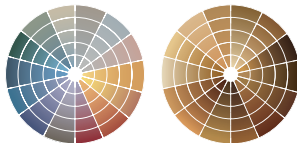

Custom Colors Available

Custom Wood-look Finishes Available

For custom options contact ASQuote, ASQuote@armstrongceilings.com

**STANDARD PERFORATION OPTIONS** (1:2 scale shown)



M1 (Unperforated)

M15 (Rd 1612)



BLADES – Standard

# new METALWORKS™ Immix™ Blades

Panelized Torsion Spring  
smooth texture



Contact TechLine for Green Genie™ information



LOCATION DEPENDENT

WHITE WITH ONLY INFILL PANEL

## VISUAL SELECTION

Item No. ♦	Description	Space Between Blades	% Open Area	lbs/SF	Dimensions Nominal W x L x H (Inches) Custom Sizes Available
METALWORKS™ Immix™ Blades Panels 15/16" Square					
6342D41_	1" wide x 4" height blade 2 blades / panel	11"	92%†	0.36 lbs	24 x 96 x 4"
6343D41_	1" wide x 4" height blade 3 blades / panel	7"	88%†	0.54 lbs	24 x 96 x 4"
6344D41_	1" wide x 4" height blade 4 blades / panel	5"	83%†	0.73 lbs	24 x 96 x 4"
6346D41_	1" wide x 4" height blade 6 blades / panel	3"	75%	1.08 lbs	24 x 96 x 4"
6342D61_	1" wide x 6" height blade 2 blades / panel	11"	92%†	0.51 lbs	24 x 96 x 6"
6343D61_	1" wide x 6" height blade 3 blades / panel	7"	88%†	0.77 lbs	24 x 96 x 6"
6344D61_	1" wide x 6" height blade 4 blades / panel	5"	83%	1.03 lbs	24 x 96 x 6"
6346D61_	1" wide x 6" height blade 6 blades / panel	3"	75%	1.54 lbs	24 x 96 x 6"
6342D81_	1" wide x 8" height blade 2 blades / panel	11"	92%†	0.66 lbs	24 x 96 x 8"
6343D81_	1" wide x 8" height blade 3 blades / panel	7"	88%	1.08 lbs	24 x 96 x 8"
6344D81_	1" wide x 8" height blade 4 blades / panel	5"	83%	1.33 lbs	24 x 96 x 8"
Other Size Panels	W: 1" H: 3" - 8" 2 - 8 blades per panel	2" - 11"	Varies	Varies	W: 24"* L: 24" - 96"

## PERFORMANCE

Dots represent high level of performance.

Sound Absorption**	Fire Performance	CleanAssure™ Disinfectable Planks		
		Fog	Spray	Wipe
0.40	Class A	*	*	*
0.45	Class A	*	*	*
0.50	Class A	*	*	*
0.55	Class A	*	*	*
0.45	Class A	*	*	*
0.50	Class A	*	*	*
0.55	Class A	*	*	*
0.55	Class A	*	*	*
0.50	Class A	*	*	*
0.55	Class A	*	*	*
Varies	Class A	*	*	*

## ACOUSTICAL INFORMATION

Dots represent high level of performance.

Infill Panel Item No.	NRC	CAC	Total Acoustics¹
8373PBBK	0.95	-	-
2821BK	0.85	35	BEST
1319	0.75	30	-

NRC with acoustical fleece See Visual Selection chart

¹ Total Acoustics™ ceiling panels have an ideal combination of sound absorption and sound blocking in one product.  
GOOD (NRC 0.60-0.65; CAC 35+)  
BETTER (NRC 0.70-0.75; CAC 35+)  
BEST (NRC 0.80+; CAC 35+)



FAST134 program items ready to ship from manufacturer in 4 weeks or less.  
Up-to-date lead times and product options (sizes and colors) at [armstrongceilings.com/fast134](http://armstrongceilings.com/fast134)

♦ When specifying or ordering, include the appropriate 6-digit perforation suffix and color suffix (e.g., 6342D61 M 1 5 W H A).  
† Icon indicates panel with unobstructed construction where the openings are at least 70% of the cross-section area and the depth of the member does not exceed the least dimension of the openings.  
\* Panel widths other than 24" will require custom panel and suspension layout. For specific options, contact your Armstrong representative to get started with our ProjectWorks® Design Services team.  
\*\* The NRC shown is achieved with M15 perforation.

BLADES - Standard

# new METALWORKS™ Immix™ Blades

Panelized Torsion Spring  
smooth texture



Contact TechLine for Green Genie™ information



## VISUAL SELECTION

Item No. ♦	Description	Space Between Blades	% Open Area	lbs/SF	Dimensions Nominal W x L x H (Inches) Custom Sizes Available
<b>METALWORKS™ Immix™ Blades Panels</b>					
<b>15/16" Square</b>					
6342D42	2" wide x 4" height blade 2 blades / panel	10"	83%†	0.5 lbs	24 × 96 × 4"
6343D42	2" wide x 4" height blade 3 blades / panel	6"	75%†	0.7 lbs	24 × 96 × 4"
6344D42	2" wide x 4" height blade 4 blades / panel	4"	67%	0.9 lbs	24 × 96 × 4"
6342D62	2" wide x 6" height blade 2 blades / panel	10"	83%†	0.65 lbs	24 × 96 × 6"
6343D62	2" wide x 6" height blade 3 blades / panel	6"	75%†	0.93 lbs	24 × 96 × 6"
6344D62	2" wide x 6" height blade 4 blades / panel	4"	67%	1.2 lbs	24 × 96 × 6"
6342D82	2" wide x 8" height blade 2 blades / panel	10"	83%†	0.8 lbs	24 × 96 × 8"
6343D82	2" wide x 8" height blade 3 blades / panel	6"	75%	1.15 lbs	24 × 96 × 8"
6344D82	2" wide x 8" height blade 4 blades / panel	4"	67%	1.5 lbs	24 × 96 × 8"
<b>Other Size Panels</b>	W: 2" H: 1" - 10" 2 - 6 blades per panel	2" - 10"	Varies	Varies	W: 24** L: 24" - 96"



FAST134 program items ready to ship from manufacturer in 4 weeks or less.  
Up-to-date lead times and product options (sizes and colors) at [armstrongceilings.com/fast134](http://armstrongceilings.com/fast134)

♦ When specifying or ordering, include the appropriate 6-digit perforation suffix and color suffix (e.g., 6342D61 M 1 5 W H A).  
† Icon indicates panel with unobstructed construction where the openings are at least 70% of the cross-section area and the depth of the member does not exceed the least dimension of the openings.  
\* Panel widths other than 24" will require custom panel and suspension layout. For specific options, contact your Armstrong representative to get started with our ProjectWorks® Design Services team.  
\*\* The NRC shown is achieved with M15 perforation

## PERFORMANCE

LOCATION DEPENDENT  
Dots represent high level of performance.

Sound Absorption**	Fire Performance	CleanAssure™ Disinfectable Planks		
		Fog	Spray	Wipe
0.40	Class A	*	*	*
0.45	Class A	*	*	*
0.50	Class A	*	*	*
0.45	Class A	*	*	*
0.50	Class A	*	*	*
0.55	Class A	*	*	*
0.50	Class A	*	*	*
0.55	Class A	*	*	*
Varies	Class A	*	*	*

## ACOUSTICAL INFORMATION

Dots represent high level of performance.

Infill Panel Item No.	NRC + CAC		Total Acoustics†
	NRC	CAC	
8373PBBK	0.95	-	-
2821BK	0.85	35	BEST
1319	0.75	30	-

NRC with acoustical fleece See Visual Selection chart

† Total Acoustics™ ceiling panels have an ideal combination of sound absorption and sound blocking in one product.  
GOOD (NRC 0.60-0.65; CAC 35+)  
BETTER (NRC 0.70-0.75; CAC 35+)  
BEST (NRC 0.80+; CAC 35+)



BLADES - Standard











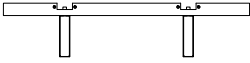

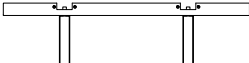

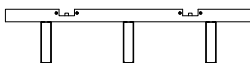

**new** METALWORKS™ Immix™ Blades

Panelized Torsion Spring  
smooth texture

 Indicates panel with unobstructed construction where the openings are at least 70% of the cross-section area and the depth of the member does not exceed the least dimension of the openings.

STANDARD PANEL CONFIGURATIONS

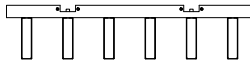
24" x 96" PANELS (1" Blade Width)

	4" Height Blades	6" Height Blades	8" Height Blades
2 BLADES	  92% Open Area Item 6342D41	  92% Open Area Item 6342D61	  92% Open Area Item 6342D81
3 BLADES	  88% Open Area Item 6343D41	  88% Open Area Item 6343D61	 88% Open Area Item 6343D81
4 BLADES	  83% Open Area Item 6344D41	 83% Open Area Item 6344D61	 83% Open Area Item 6344D81
6 BLADES	 75% Open Area Item 6346D41	 75% Open Area Item 6346D61	

◆ When specifying or ordering, include the appropriate 6-digit perforation suffix and color suffix (e.g., 6342D61 M15 W H A).











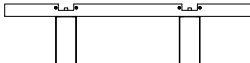

BLADES – Standard

**new** METALWORKS™ Immix™ Blades

Panelized Torsion Spring  
smooth texture

 Indicates panel with unobstructed construction where the openings are at least 70% of the cross-section area and the depth of the member does not exceed the least dimension of the openings.

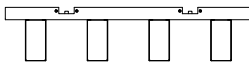
STANDARD PANEL CONFIGURATIONS

24" x 96" PANELS (2" Blade Width)			
	4" Height Blades	6" Height Blades	8" Height Blades
2 BLADES	 <p> 83% Open Area Item 6342D42_</p>	 <p> 83% Open Area Item 6342D62_</p>	 <p> 83% Open Area Item 6342D82_</p>
3 BLADES	 <p> 75% Open Area Item 6343D42_</p>	 <p> 75% Open Area Item 6343D62_</p>	 <p>75% Open Area Item 6343D82_</p>
4 BLADES	 <p>67% Open Area Item 6344D42_</p>	 <p>67% Open Area Item 6344D62_</p>	 <p>67% Open Area Item 6344D82_</p>

◆ When specifying or ordering, include the appropriate 6-digit perforation suffix and color suffix (e.g., 6342D61 M 1 5 W H Δ).



BLADES – Standard



# METALWORKS™ Immix™ Blades

Panelized Torsion Spring  
smooth texture

## HOW TO INSTALL PANELS

Step 1

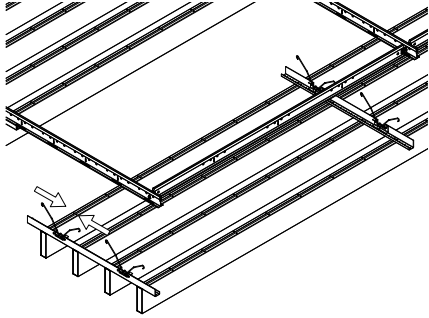

Step 2

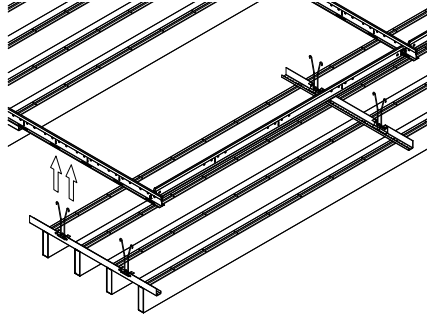

Step 3

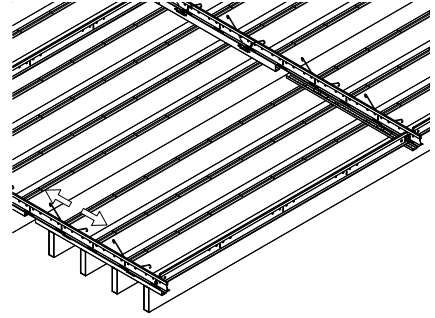

## PERIMETER CUT KIT INSTALLATION

Step 1

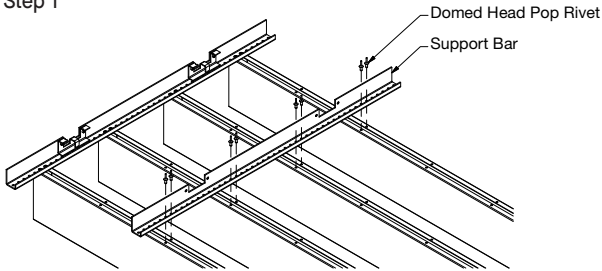

Step 2

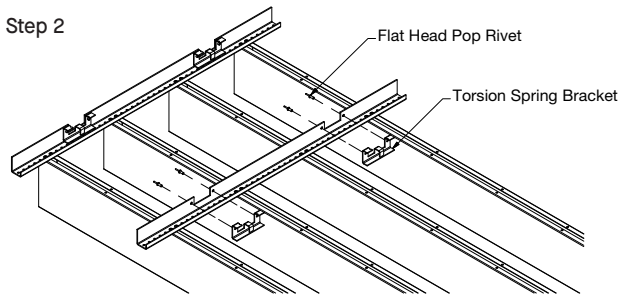

Step 3

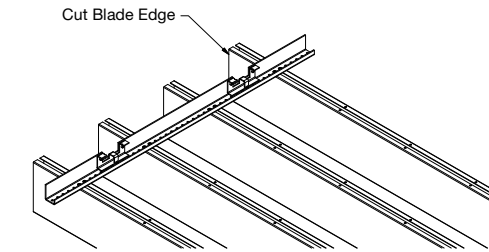

Step 4

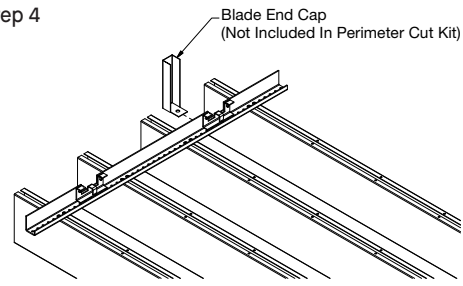

## AXIOM® FLOATING PERIMETER DETAIL

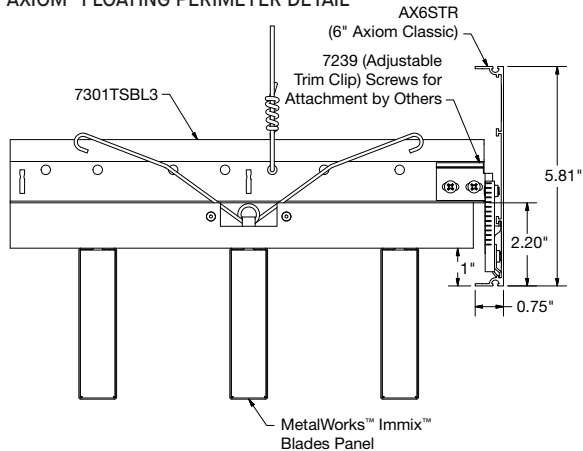

# new METALWORKS™ Immix™ Blades

Panelized Torsion Spring  
smooth texture



LEED® WELL | LBC

16% RECYCLED CONTENT

- energy management
- construction waste mgmt
- regional materials
- design for flexibility
- EPD
- recyclable/repair producer resp.

Contact TechLine for Green Genie™ information

- biobased materials
- recycled content
- sourcing of raw materials
- material ingredient reporting
- low emitting materials
- lighting quality
- acoustics

LOCATION DEPENDENT

WHITE ONLY WITH INFILL PANEL

## SUSPENSION SYSTEM & ACCESSORIES

	Item No. ◆	Description	Dimensions (Inches) Nominal W x L x H	Color	Pieces/Carton
Suspension Systems	7301TS	Prelude® XL® 12' HD Main Beam – Slotted	15/16 × 144 × 1-11/16"	White	20
	XL7341	Prelude XL 4' Cross Tee	15/16 × 48 × 1-11/16"	White	60
	7301TSBL3	Black 360 Prelude XL 12' HD Main Beam – Slotted	15/16 × 144 × 1-11/16"	Black	20
	XL7341BL3	Black 360 Prelude XL 4' Cross Tee	15/16 × 48 × 1-11/16"	Black	60
Wall-to- Wall Installations	7800_ _	12' Angle Molding	144 × 7/8 × 7/8"	White, Black Black is recommended for Sequels™ panel finishes	30
	HD7801_ _	10' Angle Molding	120 × 7/8 × 7/8"	Silver Grey, Gun Metal Grey	30
	BERC2	2" Beam End Retaining Clip	N/A	N/A	200
Floating Cloud Installations	AX6STR_ _ _ ◆	Axiom® Classic 6" Straight Trim	120 × 3/4 × 5-13/16"	White, Black, Silver Grey, Gun Metal Grey Black is recommended for Sequels panel finishes	N/A
	7239	Adjustable Trim Clip (ATC)	N/A	N/A	50
Other Accessories	5604	Perimeter Cut Kit	N/A	N/A	10 support bars/20 brackets/40 countersunk rivets, 120 domed head rivets

◆ Add the 2-digit color suffix to the item number when specifying or ordering (e.g. AX6STR S G), add an extra digit "3" before the color suffix if paint is required inside and outside of trim (e.g. AX6STR 3 S G).

## ACCESSORIES

Item No. ◆	Description	Pieces/ Carton	Item No. ◆	Description	Pieces/ Carton
5458D41M1_ _ _ _	1" wide x 4" height end cap	10	5458D42M1_ _ _ _	2" wide x 4" height end cap	10
5458D61M1_ _ _ _	1" wide x 6" height end cap	10	5458D62M1_ _ _ _	2" wide x 6" height end cap	10
5458D81M1_ _ _ _	1" wide x 8" height end cap	10	5458D82M1_ _ _ _	2" wide x 8" height end cap	10

◆ When specifying or ordering, include the appropriate 3- or 4-letter color suffix (e.g., 5458D61M1 M Y A).

## PHYSICAL DATA

**Material**  
Aluminum – thickness 0.032"

**Surface Finish**  
Painted: Factory-applied polyester paint.  
Sequels™: Pre-coated coil. Custom colors and finishes available.  
Contact ASQuote@armstrongceilings.com for custom finish requests.

**Fire Performance**  
Painted and Sequels finishes: Class A: Tested per ASTM E84. Flame Spread Index 25 or less. Smoke Developed Index 50 or less. CAN/ULC S102 surface burning characteristics. Flame Spread Rating 25 or less. Smoke Developed Classification 50 or less.

**Acoustical Options**  
Perforated panels are supplied with a black fiberglass fleece to absorb sound.

**Design Support**  
For custom design assistance contact ProjectWorks®  
Design Services or visit [armstrongceilings.com/projectworks](http://armstrongceilings.com/projectworks)

**Design Considerations**  
When installed, panels hang either 5-3/16", 7-3/16" or 9-3/16" below the face of the grid, depending on the height of the blade. MetalWorks Immix Blades panels can be cut in the field, see installation instructions for details.  
Variation in reveal between panel ends up to 1/16" may occur  
Black 360® grid minimizes grid visibility. Axiom trim colors coordinate but are not an exact match.  
For optimum visual design, backlighting panels is not recommended. For lighting integration see installation instructions.

**Installation Considerations**  
Although panels are installed from below and never travel into the plenum, MetalWorks Immix Blades panels will require a minimum 5" clearance above the suspension system. This allows enough room for the springs to travel into the plenum space during installation or removal.

**Seismic Restraint**  
MetalWorks Immix panels are approved for application in all seismic areas when installed per the seismic guidelines in the Armstrong Ceilings installation instructions.

**FAST134 Program Considerations**  
Size of Job Matters: Big jobs, over 2500 SF or 50 pieces for shapes/vertical elements will have longer lead times.  
Location Matters: Transit time not included. We are ready to ship in 1 week on FAST1 items. However, transit to the states west of Wyoming may add time.  
Distributor Truck Schedule Matters: We rely on distribution to help move products around the country. When speed matters, work with your local distributor to ensure FAST134 service.  
Stock vs. Made-to-order Matters: FAST3 & FAST4 items are made-to-order and will ship direct to distributor. FAST1 (stocked items) will go through distribution and depend on distributor truck schedules.

**Cleaning and Disinfecting**  
Cleaning and CDC-approved disinfecting options available on [armstrongceilings.com/cleaning](http://armstrongceilings.com/cleaning)

**Warranty**  
Details at [armstrongceilings.com/warranty](http://armstrongceilings.com/warranty)

**Weight**  
Refer to Visual Selection chart



BLADES – Standard