

AXIOM[®] Building Perimeter System

Assembly and Installation Instructions

1. GENERAL

1.1 Description

The Axiom[®] Building Perimeter System (AXBPS) is a pre-engineered perimeter solution to accomplish the transition between the interior of a building's perimeter and the ceiling plane. This system will consist of multiple extruded parts that interlock to form the perimeter compatible with most of the Armstrong acoustical and drywall suspension systems.

Perimeter components can incorporate drapery pockets, window shades, and air diffusers while also providing a solution for ceiling elevation changes at the perimeter.

Component Descriptions:

Axiom Building Perimeter Pocket for Attachment with 2-1/2" Studs

Aluminum pockets with distinct architectural detail create a 2- or 3-sided pocket with special bosses to accept a T-Bar connector clip and splice plate that provides a positive mechanical lock with no visible fasteners, and factory or field-cut miters to match approved shop drawings. Pockets can work directly with the ceiling system or use extensions and face plates for other design options. These pockets have an integrated sill track for placement of 2-1/2" stud drops every 48" on center. **(Fig 1)**

Axiom Building Perimeter Pocket for Traditional Framing

Aluminum pockets with distinct architectural detail create a 3-sided pocket with special bosses to accept a T-Bar connector clip and splice plate that provides a positive mechanical lock with no visible fasteners, and factory or field-cut miters to match approved shop drawings. Pockets can work directly with the ceiling system or use extensions and face plates for other design options. Pockets for traditional framing have a smooth top for attachment using wood blocking. **(Fig 2)**

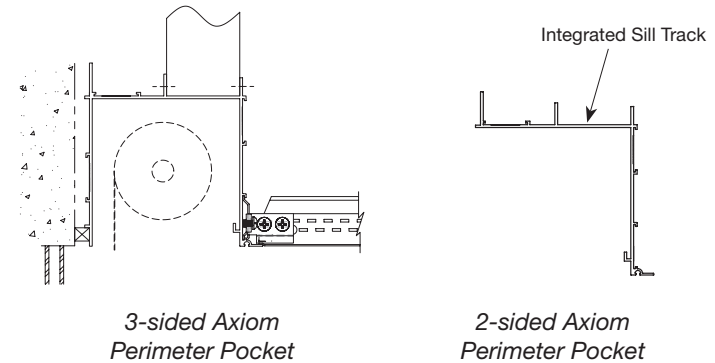

(Fig 1)

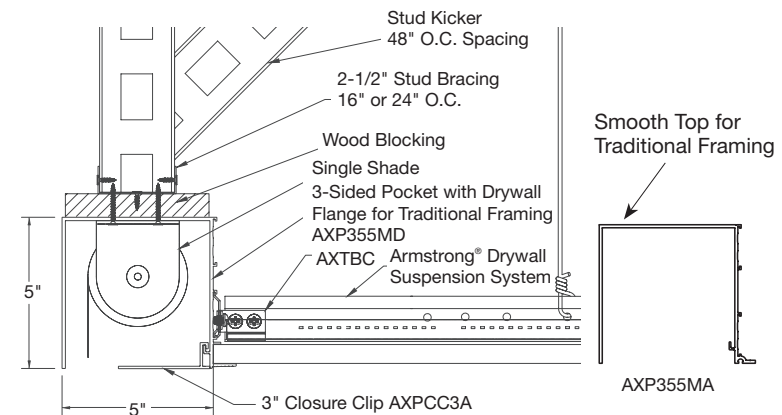

(Fig 2)

Larger double pocket details are available upon request. Double shade pockets are designed to house large roller shades or double roller shade options.

Pocketless options are available when roller shades are attached directly to the exterior of the building. (Fig 3)

Axiom Building Perimeter Extensions

Pre-engineered extension component allows design flexibility for perimeter pockets and ceiling elevation changes. The aluminum extension component fully integrates with the perimeter pocket. Extensions are available in 4", 6", and 8" heights. (Fig 4)

Axiom® Building Perimeter Face Plates

Pre-engineered face plate allows for full perimeter diffuser integration. This aluminum face plate fully integrates with the perimeter pocket component. Face plates are available 4" or 7" wide, unslotted or slotted that provides air distribution at the perimeter. (Fig 5)

Axiom Building Perimeter Closure Clips

Aluminum closure clip provides concealment of the perimeter pocket should a shade or blind be installed. (Fig 6)

See Axiom Building Perimeter System data page for the complete component list, identification, and description (BPCS-3923).

AXBPS components are available in 10' long straight sections for field fabrication and assembly. This system may require field cutting and mitering. These cuts are best made using an appropriately sized sliding compound miter saw fitted with a carbide tipped blade designed for cutting non-ferrous metals.

AXBPS can be ordered as a custom fabricated assembly. Field fabrication for custom orders is limited to component assembly and minor adjustments to accommodate differences between design dimensions and actual field conditions.

These instructions are divided into sections detailing material delivery and identification, component assembly, suspended pocket and direct-applied pocket applications, extension plates, diffuser plates, accessories, and seismic installations.

Please carefully review all appropriate sections before proceeding with installation.

2. MATERIAL DELIVERY AND IDENTIFICATION

Standard AXBPS components are delivered in full carton quantities. All hardware and instructions to assemble AXBPS will be included in the packaging. Refer to the job site shop drawings for specific AXBPS details and components. Identify all parts listed on the drawings and verify they are delivered to the site before starting the installation.

Exercise appropriate care to protect the finished surfaces of the trim.

(Custom Orders)

Custom Axiom Building Perimeter System orders will be shipped with detailed shop drawings. Please refer to these details for parts list and identification.

Review the shop drawings and packing slip to ensure that the complete order has been delivered to the site, and to familiarize yourself with the layout of the installation.

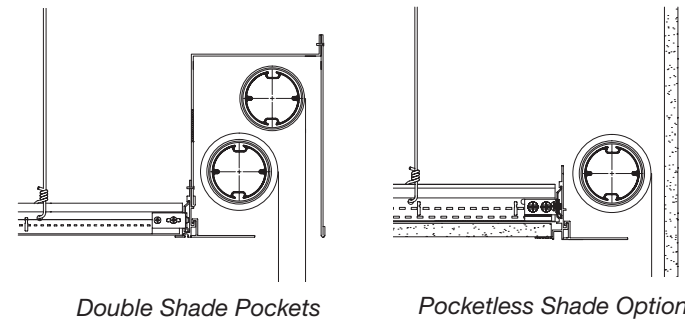

(Fig 3)

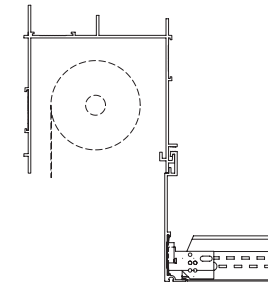

(Fig 4)

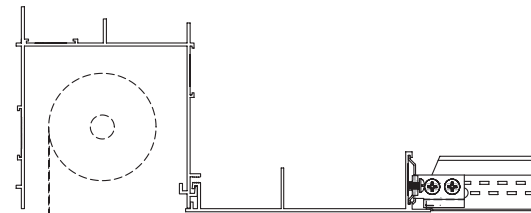

(Fig 5)

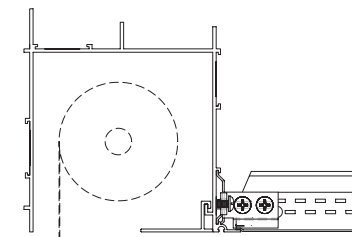

(Fig 6)

3. COMPONENT ASSEMBLIES

3.1 Splice Plates

Steel splice plates are used to align and secure joints between sections of AXBPS trim. Each joint requires a splice plate at every set of channel bosses for the proper trim alignment. Join straight sections of AXBPS using the AXSPLICE2 (2 screws) splice plate. Splice plates are secured to the trim sections using factory-installed screws. *(Figs 7 & 8)*

Typical procedure

1. Insert splices into channel trim bosses.
2. Close the joint.
3. Tighten screws.

NOTE: Splice plates can slide completely into the channel bosses and then slide into the adjoining section after trim is aligned. This will aid splice plate connections for the last piece or mitered intersections.

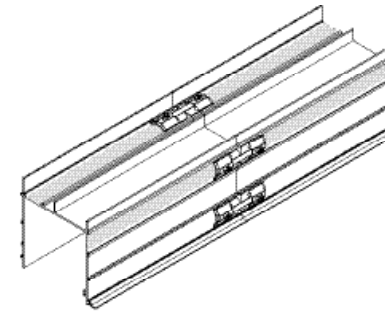

(Fig 7)

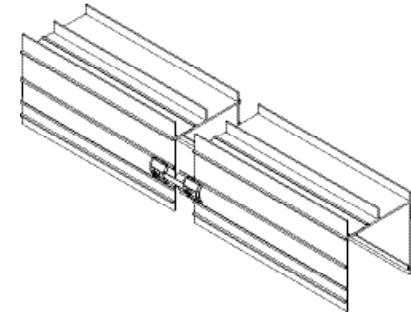

(Fig 8)

3.2 Factory-Mitered Corners

AXBPS perimeter pockets are available with factory-mitered corners. Mitered sections of trim will measure nominal 12" along the inside flange of the miter. Factory-mitered corners ship in sections and must be assembled on the job. All hardware is included. The mitered ends of AXBPS are joined using the AX4SPLICEB (4 screws). These can easily be bent to a 90° angle to join the corner together. The square ends are attached to adjoining straight sections of Axiom trim using the AX4SPLICEB (4 screws) splice plates.

AXBPS pocket-mitered corner trim should be installed before the straight sections. Work away from the corners and field-cut straight sections, as needed.

Field mitering AXBPS perimeter pockets is not recommended due to the shape and size of the trim.

AXBPS extension pieces and face plates can be cut and mitered in the field for the best fit. These cuts are best made using an appropriately sized sliding compound miter saw fitted with a carbide tipped blade designed for cutting non-ferrous metals. *(Fig 9)*

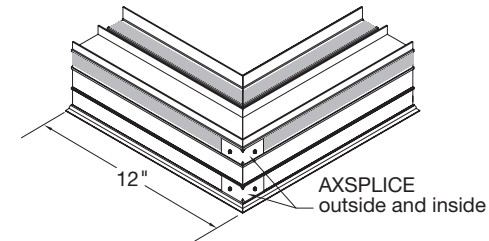

(Fig 9)

3.3 AXBPS Foam Gasket

Self-stick, field-applied 1/2" x 1/2" foam gasket is recommended along the outside edge of pocket trim to seal along the wall and make up for slight wall irregularities. Gasket is recommended for each linear foot of AXBPS pocket. *(Fig 10)*

Typical procedure

1. Install the gasket just below the tab of the outside edge of the AXBPS pocket.
2. Peel the release paper off the gasket as it is applied by hand to the trim.
3. Trim the gasket with a sharp utility knife or scissors.

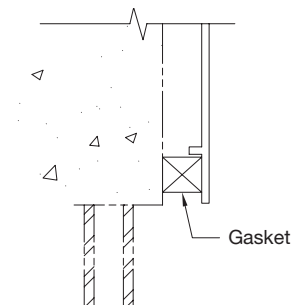

(Fig 10)

3.4 AXBPS Spline

Axiom± Building Perimeter Spline (AXPSPLINE) (0.175" diameter) is required to lock AXBPS perimeter extensions and face plates to the pocket trim. The spline also helps maintain trim alignment. Spline is required for each linear foot of AXBPS extension or diffuser trim. **(Fig 11)**

Typical procedure

1. Engage the AXBPS extension/diffuser trim hook into the AXBPS pocket connector.
2. Insert the spline by hand into the void above the hook.
3. Trim the spline with a sharp utility knife or scissors.

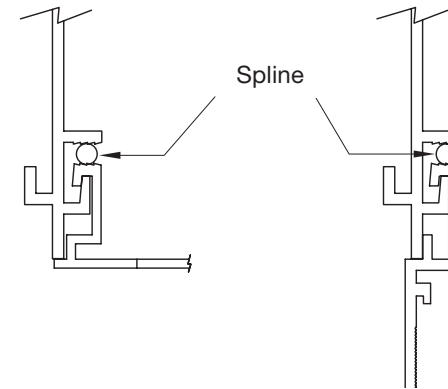

(Fig 11)

3.5 T-Bar Connector Clips

Axiom T-Bar Connector Clips (AXTBC, AX-V-TBC) are used to attach the ceiling suspension systems to the AXBPS trim components. These two-piece steel clips are supplied as an assembled unit with the steel locking screw factory installed. One clip is required at each location where the suspension system intersects the AXBPS trim.

There are two versions of the T-Bar Connector Clip:

1. AXTBC is used with drywall, lay-in, tegular, concealed tile, and installations of Vector® panels that are all full size.
2. AX-V-TBC is used with cut Vector panels.

T-Bar Connector Clips are attached to the suspension system members using screws supplied by the installer. Framing screws (#6 x 7/16" or 1/2" long) are typical. Special conditions such as open-cell installations may dictate the use of alternate methods of attachment such as pop rivets. **(Fig 12)**

See installation section for alignment of the AXTBC connector clip to the suspension system member.

Typical procedure

1. Cut suspension system to length.
2. Attach clip to suspension system member.
3. Engage clip in channel bosses and tighten locking screw.

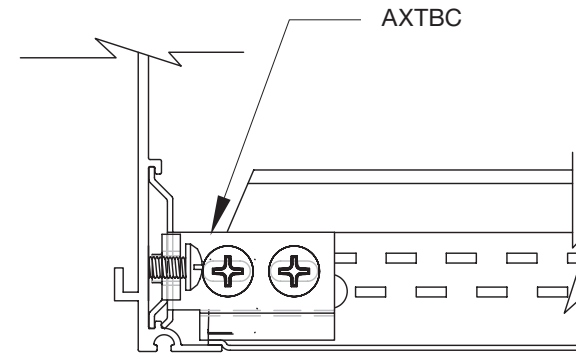

(Fig 12)

3.6 Drywall Flanged Products

Utilize AXP355D or AXP355MD pockets for integration with drywall. Drywall trim is fastened using standard drywall screws applied through the taping flange of the trim into the drywall suspension system. The trim is finished using standard drywall materials and techniques. Normally, the drywall and Axiom trim are then painted to meet job requirements. **(Fig 13)**

Typical procedure

1. Attach the drywall suspension system to the AXBPS trim with an AXTBC.
2. Attach 5/8" drywall to the system.
3. The framer should provide backing so that moldings may be attached with #6 drywall screws 16" O.C. for horizontal applications.

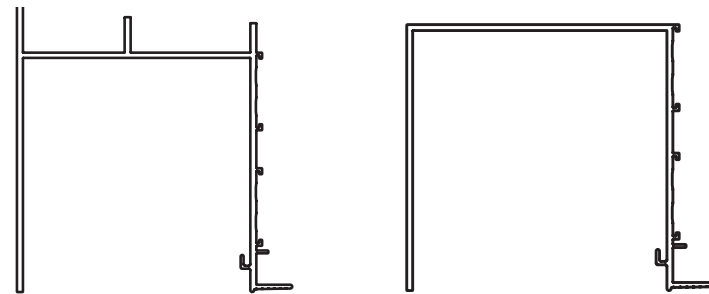

(Fig 13)

4. Prior to taping, the attachment flanges should be cleaned using a non-abrasive cleaner and soft rag. When veneer plaster is specified, the flanges must be treated with a bonding agent.
5. Make sure the tape does not overlap the edge of the reveal and an 8" wide trowel is used to apply the final skim coat.
6. Fiberglass self-adhesive drywall tape will cut taping time and help to avoid possible cracking.
7. Tape and finish drywall.
8. Paint. *(Fig 14)*

Typical procedure

1. Attach the drywall suspension system to the AXPMPD or AXPMP38D.
2. Tuck the drywall above the taping flange and attach to drywall suspension system framing.
3. Tape and finish drywall.
4. Paint.

Tapable Flange Installation

1. Install the moldings after the gypsum board is mounted in place.
2. Provide backing so that the moldings may be attached with #6 drywall screws 16" O.C. for horizontal applications.
3. Prior to taping, the attachment flanges should be cleaned using a non-abrasive cleaner and soft rag. When veneer plaster is specified, the flanges must be treated with a bonding agent.
4. Be sure the tape does not overlap the edge of the reveal and an 8" wide trowel is used to apply the final skim coat.

NOTE: Fiberglass self-adhesive drywall tape will reduce taping time and help avoid possible cracking.

3.7 Metal Panel Hold-Down Clips

Metal panel hold-down clips (AXSPTHDC) are used to secure the cut edges of metal ceilings at the AXBPS trim. Insert one clip for every foot of perimeter, or as needed to maintain contact between the panel edge and the flange of the trim. *(Fig 15)*

Typical procedure

1. Install the metal panel.
2. Insert the top of the clip into the channel first.
3. Press up to compress the clip.
4. Insert the bottom leg into the channel.

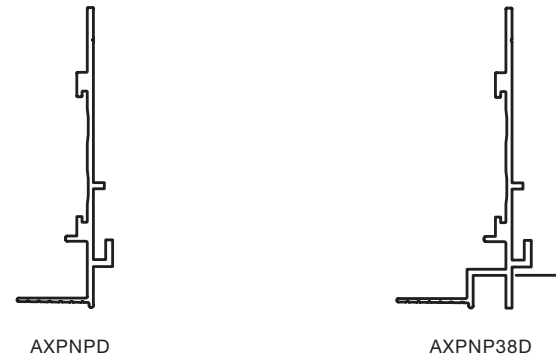

Axiom Pocketless details can also be used to integrate with drywall.

(Fig 14)

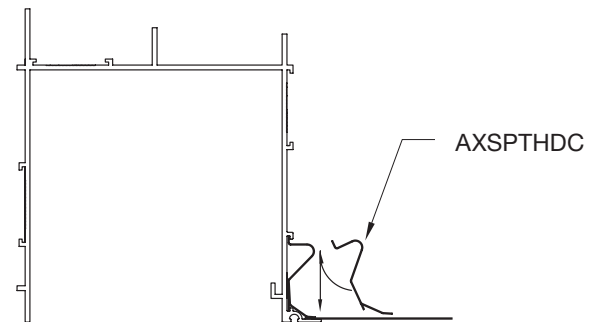

(Fig 15)

3.8 Axiom Building Perimeter Shade Pocket Installation for Attachment with 2-1/2" Studs

The AXBPS pocket is the main component for the building perimeter trim system. The pocket is available 2-sided or 3-sided, depending on the design and installation requirements. Installation procedures are the same for 2- and 3-sided pockets.

AXBPS pocket top flanges are spaced to fit standard 2-1/2" metal studs for support or bracing to structure. The AXBPS pocket has two options for mounting to the structure — free-floating from the wall or direct attached to the wall.

NOTE: Mechanically fastened connections at all locations are critical to the system support. Failed, damaged, or stripped fasteners must be replaced. Follow the fastener manufacturer's installation recommendations.

Refer to the job plan to determine the elevation of the AXBPS pocket.

NOTE: It is important the pockets be installed level within 1/16" over 15' for roller shade applications. (Fig 16)

Typical procedure

1. Fasten a 2-1/2" track or wood blocking to the structure directly above the AXBPS perimeter pocket track location. Use appropriate fasteners along the track to carry the weight of the AXBPS.
2. Cut nominal 2-1/2" metal studs to fit between the structure track and the AXBPS pocket track.
3. Install the 1/2" x 1/2" self-stick foam gasket just below the tab along the bottom outside edge of the AXBPS pocket.
4. Use a laser or leveling device and temporarily secure the AXBPS pocket to several studs with clamps or vice grips.
5. Use sheet metal screws, type #8 x 1/2" framing screw, to attach both sides of the stud to the AXBPS track.
6. Studs should be located every 24" inches (maximum stud spacing is 48" O.C.) along the track or as required by local authorities.
7. Use diagonal bracing to structure, as needed, to maintain the correct alignment of the AXBPS pocket.

The foam gasket will seal the AXBPS pocket along the wall and make up for wall irregularities.

3.9 Traditional Framing Pockets and Custom Double Shade Pocket Assembly – Free Floating from Wall

1. Using 3-5/8" stud framing, provide framing 48" O.C. attached to a track as shown in the drawing below.
2. Attach 3/4" plywood blocking the width of the pocket less 1/4". Leave 1/4" between the wood and the exterior wall for the pocket flange to slide into.
3. The height of the wood blocking should be the finished ceiling height minus the custom pocket height.
4. Once framing is complete, lift the pocket in place and screw from the interior of the pocket to hold the pocket in place.
5. Attach the suspension system to AXTBC and insert into the perimeter bosses. (Fig 17)

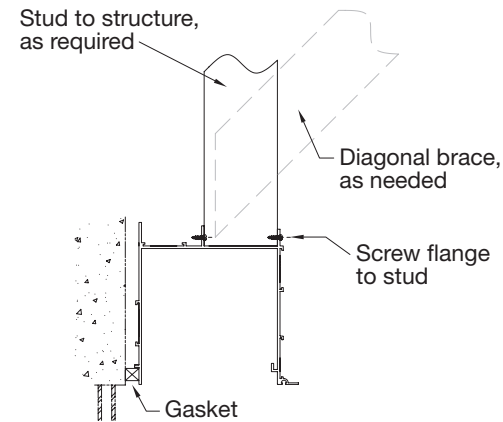

(Fig 16)

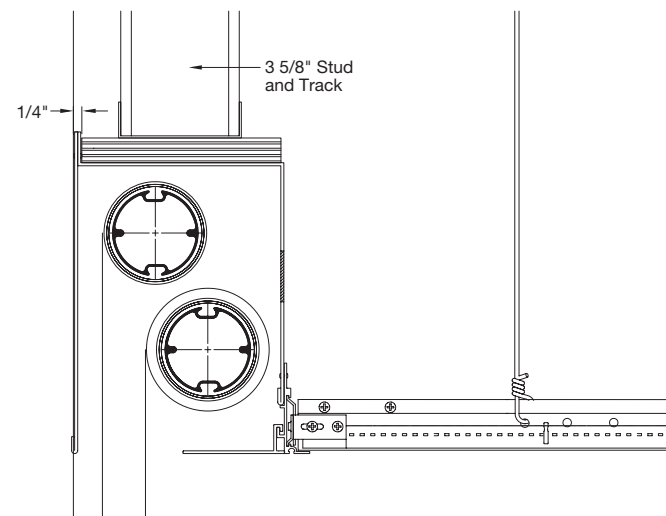

(Fig 17)

3.10 Axiom Building Perimeter Pocket – Attached to Wall

Refer to the job plan to determine the elevation of the AXBPS pocket. The pocket can be attached directly to the wall structure or blocking. Attach blocking to the structure and shim as needed to correct any wall irregularities. Attach the AXBPS perimeter pocket to the blocking. **(Fig 18)**

Typical Procedure

1. Attach blocking to the wall structure with the appropriate fasteners. Shim, as needed, at any wall irregularities to create a straight run.
2. Pre-drill clearance holes every 16" to 24", or as needed, along the top wall flange of the pocket.
3. Install the 1/2" x 1/2" self-stick foam gasket just below the tab along the bottom outside edge of the AXBPS pocket.
4. Use a laser to level the pocket along the wall and secure it to the blocking every 16" to 24", or as required, by local authorities.
5. The front of the pocket can be supported with 12-gauge wire or a strut. Pre-drill a clearance hole in the top front flange to attach a hanger wire. Attach hanger wire to structure, then to the pocket. Wire spacing should not exceed 48".

NOTE: All hanger wire holes must be drilled to have a minimum of 1/4" between the top of the hole and the top of the flange for load requirements.

The foam gasket will seal the AXBPS pocket along the wall and make up for slight wall irregularities.

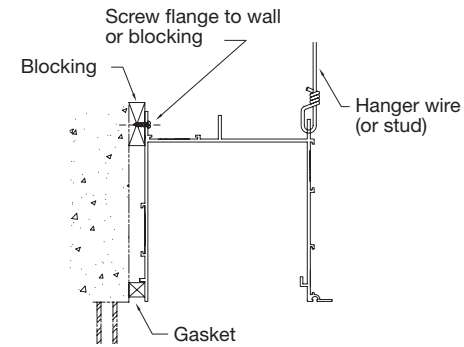

(Fig 18)

3.11 Custom Double Shade Pocket Assembly – Attached to Wall

1. Pre-drill holes in the top flange of the pocket every 16" or 24" as required.
2. Attach top of pocket to wall structure through the pre-drilled holes. Shim, as needed, at any wall irregularities to create a straight run.
3. Use a laser to level the pocket to within 1/16" over 15 feet.
4. Attach pocket to the suspension system using the AXTBC clips provided.
5. Using a 3-1/2" stud to structure, screw-attach the stud to the suspension system as shown in the drawing below.
6. Attach blocking to the top of the pocket as required by the window shade manufacturer. **(Fig 19)**

3.12 AXBPS Perimeter Pocket, 2-sided Transition

Axiom pocket with acoustical/drywall integration on both sides (AXP3552). This concept was generated from the idea of taking our perimeter pocket and bringing it into the interior of a building, while allowing ceiling systems to come in on both sides (acoustical or drywall).

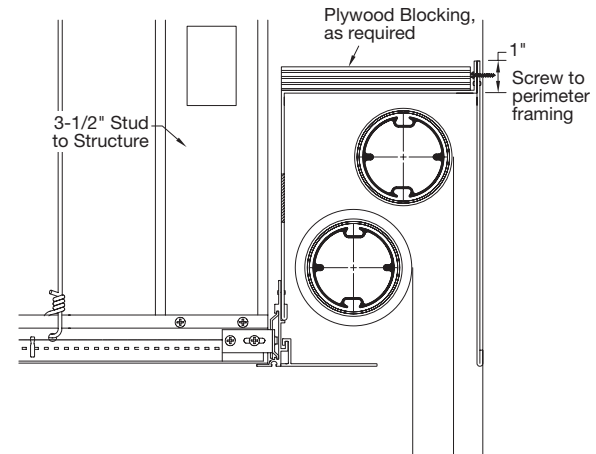

(Fig 19)

3.13 AXBPS Field Face Plate, 2-sided transition

Axiom Field Face Plate with acoustical integration on both sides (AXFFP). Can be used as a face plate to accept a middle-of-the-room diffuser or a light fixture. Custom cutouts are available. This component can also be used to resemble a simple bulkhead or separation between two ceiling systems. (Fig 20)

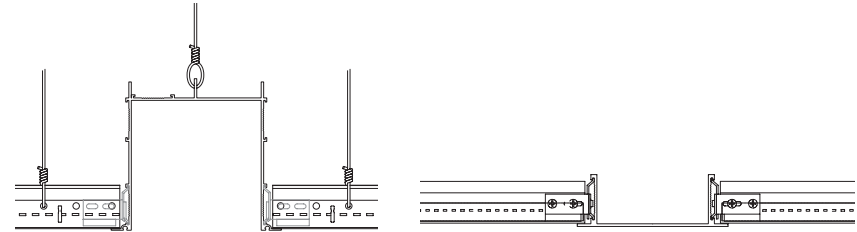

(Fig 20)

3.14 AXBPS Extension and Diffuser Face Plate Installation

AXBPS can use extension and diffuser face plates to create a variety of solutions to meet perimeter trim design options. You must use AXBPS perimeter pockets with connections for extension and diffuser face plates. Extensions and diffuser plates are field-cut and mitered, as required. These cuts are best made using an appropriately sized sliding compound miter saw fitted with a carbide-tipped blade designed for cutting non-ferrous metals. AXBPS extensions and diffusers work with most of the Armstrong acoustical and drywall suspension systems.

3.15 Axiom Building Perimeter Extensions

AXBPS extensions come in straight 10' lengths and nominal 4, 6, and 8" widths. They are used for an elevation change between the pockets and finish height of the ceiling. Refer to job drawings for specific elevations and details. (Fig 21)

Typical Procedure

1. Use a full-length section or field cut, as required.
2. Extension plate joints must be staggered or offset from the pocket joint by a minimum of 2". for strength and proper system alignment.
3. Insert the appropriate splice plates in channel bosses.
4. Tilt the extension plate to allow the top hook to fit into the pocket connection.
5. Lower the extension plate to the vertical position and the extension hook locks under the bottom of the pocket.
6. Insert the spline.
7. Vertical alignment may require diagonal bracing to structure.

Continue installing extension plates, as required. Pull sections together tightly before securing the splice plate setscrews.

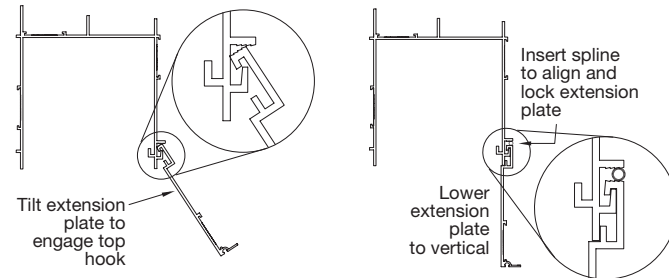

(Fig 21)

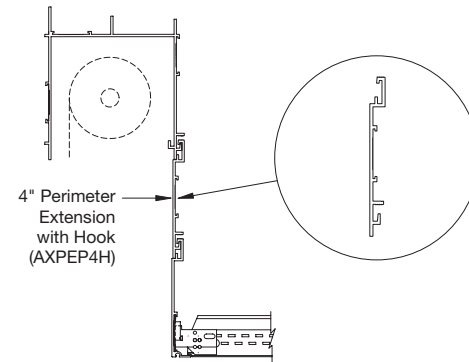

(Fig 22)

3.16 AXBPS Extension, Hook on Both Sides

4" extension with "hook detail" on both sides (AXPEP4H). This allows two possibilities: 1) Allows for an extension and a face plate to be used in conjunction with each other (Fig 22); and, 2) Allows for more flexibility as it can be used in combination with other extension pieces for greater ceiling elevation changes not currently addressed in our offering.

3.17 AXBPS Face Plates

AXBPS face plates come in straight 10' lengths and nominal 4" and 7" widths. They are used for perimeter diffuser integration or as horizontal extension plates. Refer to job drawings for specific details. (Fig 23)

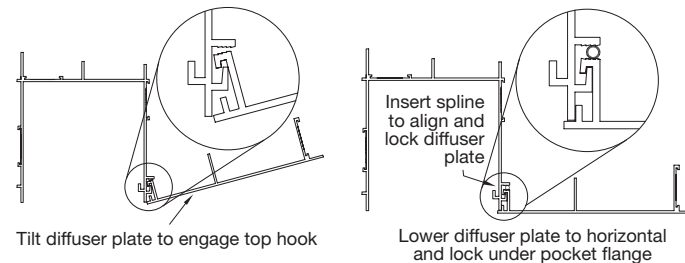

(Fig 23)

Typical Procedure

1. Use a full-length section or field cut, as required.
2. Face plate joints must be staggered or offset from the pocket joint by a minimum of "2. for strength and proper system alignment.
3. Insert the appropriate splice plates in channel bosses.
4. Tilt the face plate to allow the top hook to fit into the pocket connection.
5. Lower the face plate to the horizontal position and the hook locks under the bottom of the pocket.
6. Insert the spline.
7. Level the face plate, as needed, with 12-gauge hanger wire or vertical strut. Each section of trim requires a minimum of two attachments to structure.

Continue installing face plates, as required. Pull sections together tightly before securing the splice plate setscrews.

3.18 Axiom® Wall Clip with Hook

Take the wall clip (AXPWC), attach it to your exterior or interior wall, and hook on the face plate. (Fig 24)

The AXPWC can be used to attach a closure clip at the wall. (Fig 25)

Installing HVAC Boots

1. Fit the HVAC boot over the slotted section of the diffuser plate.
2. Secure boot to the face plate as per the boot manufacturer's recommendations.
3. Provide additional support, 12-gauge hanger wire, or stud, as needed. (Fig 26)

3.19 Perimeter Closure Clip

AXBPS Perimeter Closure Clip fits inside the room side of the pocket to close off or reduce the opening of the pocket. It is available "2. and "3. wide and 10' in length. (Fig 27)

Typical Procedure

1. Use a full-length section or field cut, as required.
2. Closure clip joints must be staggered or offset from the pocket joint by a minimum of "2. for strength and proper system alignment.
3. Install all hardware inside the pocket before installing the closure clip.
4. Insert the closure clip top hook into the channel on the inside of the pocket.
5. Lower the closure clip until the hooks engage and rest against the inside of the pocket.

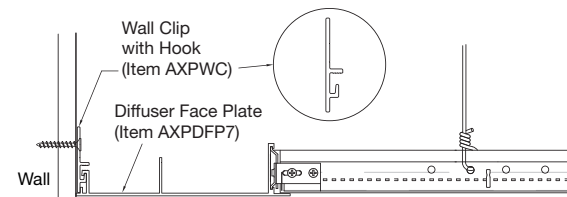

(Fig 24)

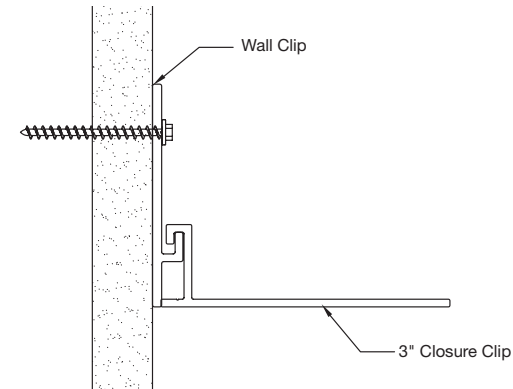

(Fig 25)

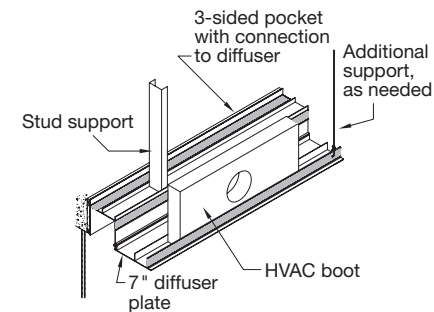

(Fig 26)

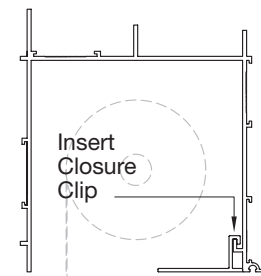

(Fig 27)

3.20 Axiom Perimeter End Plates

Use the end plate to close off the AXBPS pocket at open ends to conceal curtain ends, seal the pocket at partition walls, or as needed. **(Fig 28)**

Typical Procedure

1. Fit end cap into the pocket with the attachment flange against the top.
2. Secure the end cap with self-drilling sheet metal screws (typically #8 x 1"2.) through the clearance holes in the flange.

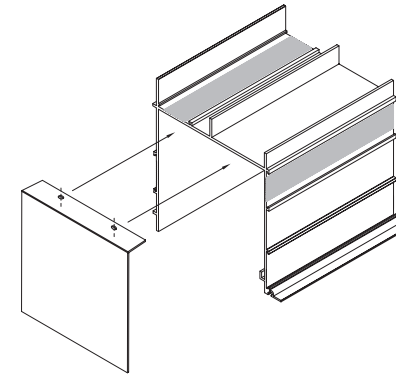

(Fig 28)

3.21 Installing Shades or Fixtures

AXBPS is designed to interface with shades and other fixtures along the building perimeter. Refer to the shade or fixture manufacturer for installation and fastening recommendations of their product to the AXBPS pocket.

Shade or fixture weights may require additional support or blocking of AXBPS pockets to meet structure requirements. Refer to the manufacturer's data pages for load data.

4. ATTACHING SUSPENSION TO AXBPS

AXBPS trim components are installed before the acoustical or drywall grid systems. Most acoustical and drywall suspension systems will attach directly to all AXBPS trims. There are several options for the Axiom® connector clip used to attach the grid to the AXBPS trim. Carefully review these options for the systems you are installing. **(Fig 29)**

Typical Procedure

1. Refer to the reflected ceiling plan for the suspension system layout.
2. Determine the size of the border panel next to the AXBPS trim.
3. Install the suspension system so the suspension system will rest 3"8. on the AXBPS trim flange.
4. Select the correct Axiom T-Bar connector clip (AXTBC) for your suspension system option listed below.
5. Rest the bottom of the clip on the flange of the suspension system.
6. Attach the clips by aligning the end of the elongated hole 1"4. from the cut end of the suspension system and inserting a standard framing screw into the center of the slot.
7. Use a Phillips screwdriver to loosen the locking screw on the lower plate.
8. Engage the top ear of the connector clip under the boss of the AXBPS channel trim. Slide the lower leg downward to engage the lower boss on the trim and secure by tightening the locking screw.
9. Loosen the locking screw and adjust the clip, as necessary, to properly align the suspension system.
10. Insert a second framing screw through the other hole in each of the connector clips.

Axiom Connector Clip Options

4.1 T-Bar suspension system for Prelude® and Suprafine® suspension system will rest on the lower flange of the Axiom Trim – full-size Vector® panels – use standard AXTBC. **(Fig 30)**

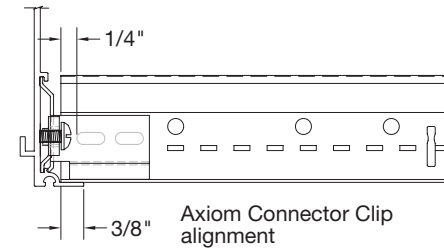

(Fig 29)

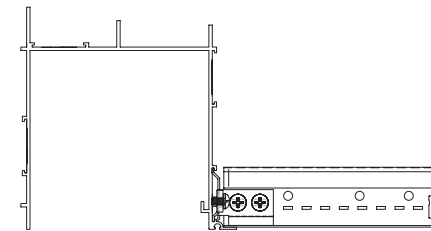

AXTBC standard clip,
suspension system flush

(Fig 30)

Follow steps 5 – 10 of typical procedure.

4.2 Silhouette®, Interlude®, Trimlok®, and Sonata® (systems with a 5/8" shoulder height), Tegular panels on Prelude or Suprafine with the panel face resting on the trim flange, and 5/8" concealed tile.

The suspension system must be held 1"4. above the AXBPS flange. Modify the AXTBC by cutting 1"4. off the bottom of the clip at the score line. **(Fig 31)**

Follow steps 5 – 10 of typical procedure.

4.3 MetalWorks™ Vector (cut panels) and 3"4. concealed tile – use standard AX-V-TBC.

The suspension system must be held 3"8. above the AXBPS flange. **(Fig 32)**

Follow steps 5 – 10 of typical procedure.

Use AXSPTHDC to hold down cut metal panel edges on AXBPS trim.

4.4 Ultima®, Optima®, and WoodWorks® Vector (cut panels) – use AX-V-TBC.

The suspension system must be held 1"2. above the AXBPS flange.

Modify the AX-V-TBC by cutting 1"8. off the bottom of the clip at the score line. **(Fig 33)**

Follow steps 5 – 10 of typical procedure.

5. AXBPS COMPONENT SUPPORT

The manufacturer requires that the AXBPS and the ceiling suspension systems be installed and supported in a manner that complies with all applicable codes and standards.

The following chart provides recommendations for support of AXBPS components:

Pockets (2-sided / 3-sided)	Non-Seismic	Seismic
Stud spacing for pockets with attachment using 2-1/2" studs (Floating pocket)	4 ft O.C.	4 ft O.C. or as required by local authority
Stud spacing for traditional framing pockets	16" or 24" O.C.	16" or 24" O.C.
Stud/wire spacing (Attached pocket)	4 ft O.C.	4 ft O.C.
Hanger wire spacing	4 ft O.C.	4 ft O.C.
Diffuser Plate Stud spacing	4 ft O.C.	4 ft O.C.
Hanger wire spacing	4 ft O.C.	4 ft O.C.
Vertical Extension Plate* Bracing	4 ft O.C.	*

Minimum of 2 studs/2 hanger wires are required per section of trim. Mitered corner assemblies require one stud / hanger per assembly.

*** Seismic Installations** – In severe seismic areas, professional design engineering is required for lateral force bracing. Floating AXBPS pockets require diagonal bracing to structure every .8" O.C. Seismic restraint requirements may require wires attached to each suspension system member within .8" of the cut end along the Axiom® Building Perimeter Trim.

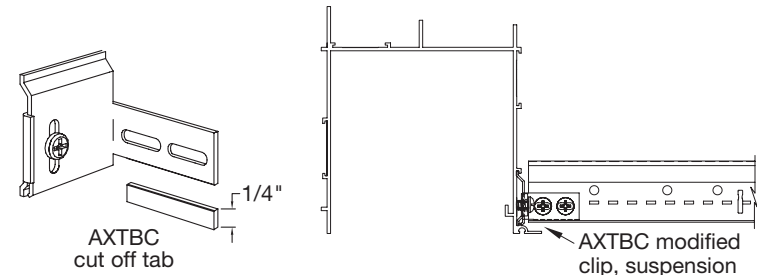

(Fig 31)

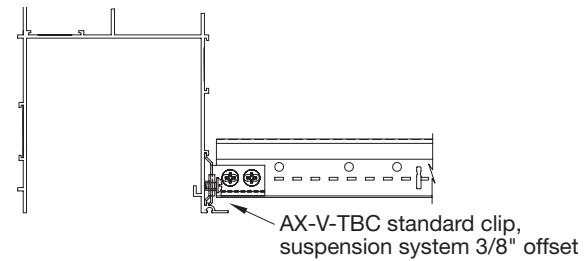

(Fig 32)

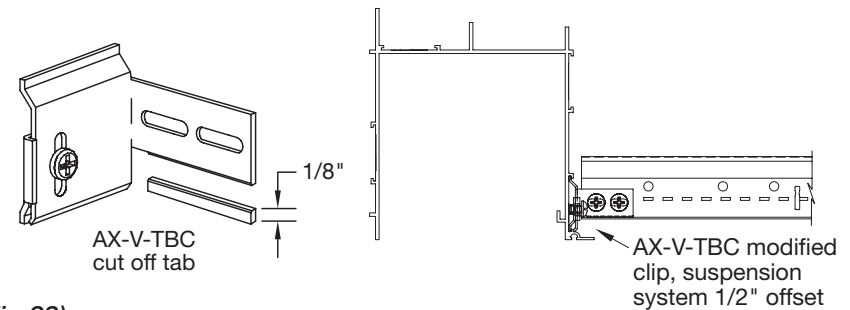

(Fig 33)

Seismic Components

All seismic AXBPS solutions install the same way as our standard AXBPS components. (Fig 34)

6. INSTALL CEILING PANELS, TILE, OR DRYWALL

- 6.1 Cut and install tiles or panels using standard procedures for the specified products.
- 6.2 Treat exposed cut edges of ceiling panels as detailed in the project specifications.
- 6.3 For drywall applications, attach 5"8. gypsum panels to the suspension system per the manufacturer's recommendations.

7. FINAL DETAILING

- 7.1 Check and adjust the alignment of suspension system and ceiling panels.
- 7.2 Clean exposed surfaces, as required. Painted Axiom components may be wiped down with a mild household cleaner to remove fingerprints, oil, etc.
- 7.3 Touch up painted components, as required. All painted custom Axiom shipments include a container of paint to be used for touch up.

3-Sided Seismic Perimeter Pocket, Acoustical/Drywall Transition with 0.875" flange (AXP355S)

Larger custom pockets are also available with the 0.875" seismic flange.

Seismic Perimeter Extension 6" with 0.875" flange (AXPEPS6)

Seismic Perimeter Diffuser Face Plate 7" with 0.875" flange (AXPDFPS7)

Beam End Retaining Clip for seismic installations (BERCAXT)

Axiom Adapter Clip with 0.75 Flange attaches to standard pocket, extension, and diffuser face plate flanges for seismic installations (AXSA75)

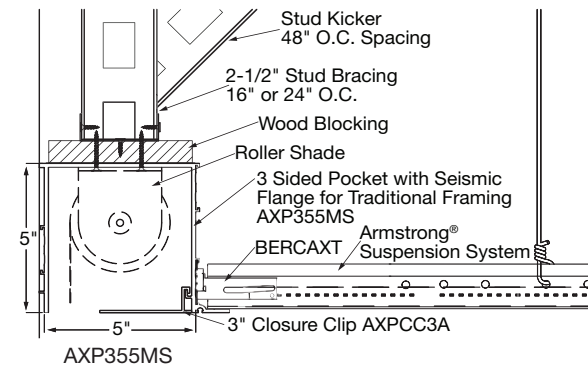
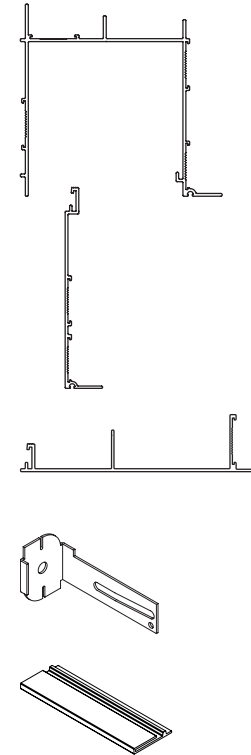

(Fig 34)

MORE INFORMATION

For more information, or for an Armstrong Ceilings representative, call 1 877 276 7876. For complete technical information, detail drawings, CAD design assistance, installation information, and many other technical services, call TechLine customer support at 1 877 276 7876 or FAX 1 800 572 TECH. All other trademarks used herein are the property of AWI Licensing LLC and/or its affiliates. © 2022 AWI Licensing Company Printed in the United States of America

Armstrong
CEILING & WALL SOLUTIONS