

Axiom® Indirect Light Coves

Assembly and Installation Instructions

1. GENERAL

1.1 Product Description

The Axiom® Indirect Light Cove system is a pre-engineered lighting solution designed to be used at a ceiling-to-wall condition or a ceiling-to-ceiling transition and integrate with Armstrong® acoustical or drywall ceiling systems. The system consists of an extruded aluminum component and a brake-formed sheet metal component, and is designed to accept a pre-engineered light manufactured and provided by Axis Lighting, Litecontrol, or Vode® Lighting.

NOTE: Axiom Indirect Light Coves are designed to integrate with Axis CovePerfekt™, Litecontrol ACOVE15AL, or Vode® ZipWave™ | LED | 707 light fixtures only.

1.2 Component Description

Axiom Indirect Light Coves

Extruded aluminum face factory assembled with rigid sheet aluminum to form an indirect light cove with distinct architectural features, creating a 2-sided light cove at the wall and at a ceiling-to-ceiling transition. Special bosses are provided to connect AXTBC T-Bar Connector Clips and AX4SPLICE splice plates to provide positive attachment with no visible fasteners. There are two profile designs with varying elevations and face edge options to accommodate most situations – a 4" ceiling-to-ceiling cove and a 4" ceiling-to-wall cove. Both coves have Knife Edge® and Classic trim options. The ceiling-to-wall cove can be ordered with an 8" or 10" elevation. The ceiling-to-ceiling cove can be ordered with a 12", 14", 16", 18", or 20" elevation change. Pockets can be ordered with an optional plenum air slot opening (**Figs 1, 2 and 3**).

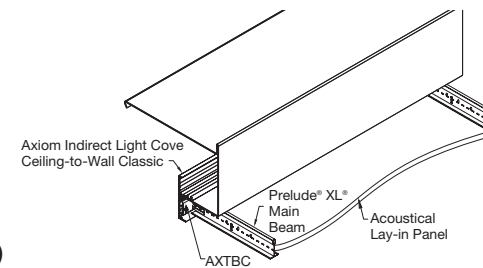

(Fig 1)

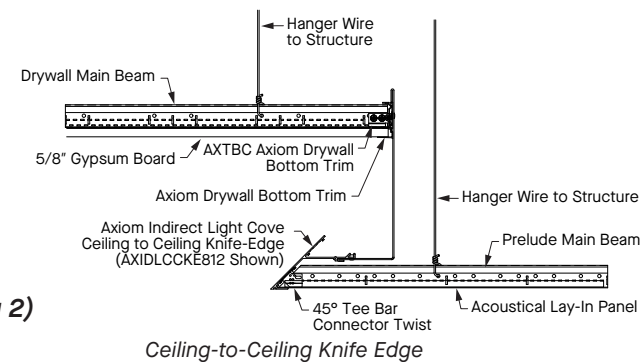

(Fig 2)

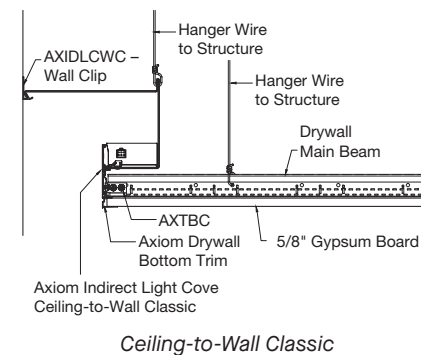

(Fig 3)

Axiom Indirect Light Cove corners can be ordered in both the knife edge and classic trim for both the ceiling to wall cove and the ceiling to ceiling cove. The pre-made factory finished inside and outside corners are made to match the elevation of your straight indirect cove sections. Each corner section is 12" by 12" square (dimension taken on the face of the extrusion) (Fig 4).

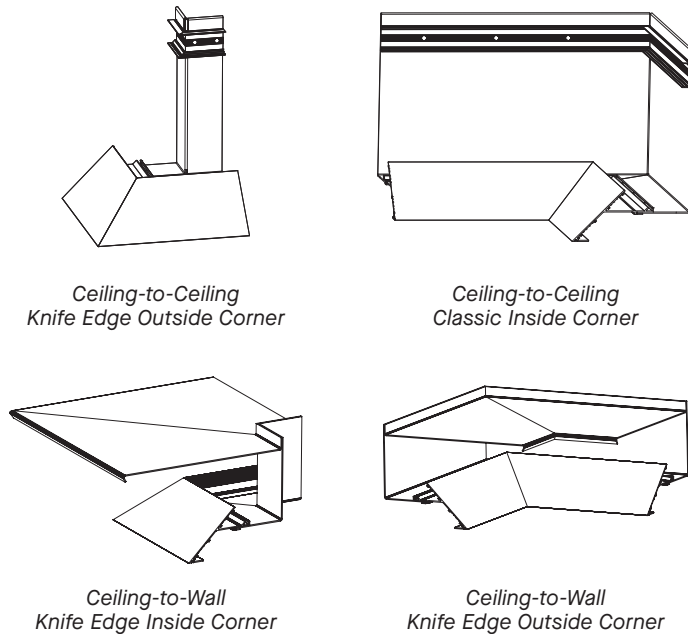

(Fig 4)

2. MATERIAL DELIVERY AND IDENTIFICATION

Axiom Indirect Light Coves are packaged and delivered in the quantities ordered. All hardware and instructions for assembly will be included in the packaging. Custom projects may include shop drawings as well. Identify all parts listed in the drawings and verify they are delivered to the site before starting the installation. Exercise care to protect the finished surfaces of the trim.

3. COMPONENT ASSEMBLY

3.1 Splice Plates

Steel splice plates are used to align and secure joints between sections of the light cove trim. Each joint requires a splice plate at every set of bosses for proper trim alignment. Join straight sections of cove together using the AX4SPLICEB splice plate. Splice plates are secured to the trim sections using factory-installed setscrews. A 1/8" hex key is included with the hardware (Fig 5).

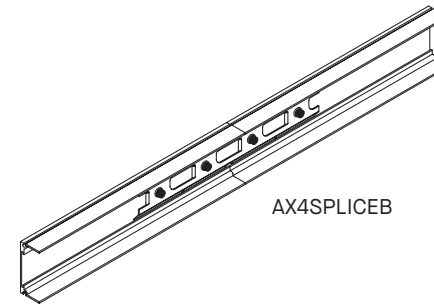

(Fig 5)

NOTE: Splice plates can slide completely into the channel bosses and then slide into the adjoining section after the cove is aligned. This will aid splice plate connections for the last piece.

3.2 T-Bar Connector Clips

There are two versions of the T-Bar Connector Clip:

- AXTBC is used with drywall, lay-in, Tegular, concealed tile, and installations of Vector® panels that are FULL SIZED tile. These are INCLUDED with each shipment.
- AXCCCLT45 is used with Axiom® Knife Edge® Light Cove trim.
- AX-V-TBC is used with CUT Vector panels. These will need to be ordered separately.

T-Bar Connector Clips are attached to the suspension system members using screws supplied by the installer. Framing screws (#6 x 7/16" or 1/2" long) are typical. See general installation instructions for alignment of AXTBC, AXCCCLT45, or AX-V-TBC connector clip to the suspension system member (Fig 6).

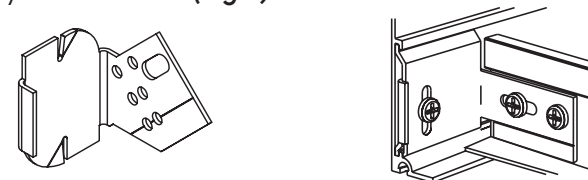

(Fig 6)

AXCCCLT45: Used with Axiom Knife Edge Trim

AXTBC: Provides positive mechanical lock with Factory-installed screw

Typical Procedure

1. Cut suspension system to length.
2. Attach AXTBC clip to suspension system member.
3. Engage AXTBC clip in channel bosses and tighten locking screw.
4. For Axiom Knife Edge trim, use the AXCCLT45 clip.

See section 5.1 (Attaching to Suspension System) for alignment and installation methods for the AXTBC clip and associated suspension system components.

3.3 Drywall Trim

Drywall bottom trim (AXBTSTR) is added to finish the edges of 5/8" drywall applied to the bottom surface of the Axiom Light Cove. Drywall trim is fastened using standard drywall screws applied through the taping flange of the trim into the drywall suspension system. The trim is finished using standard drywall materials and techniques (Figs 7 and 8).

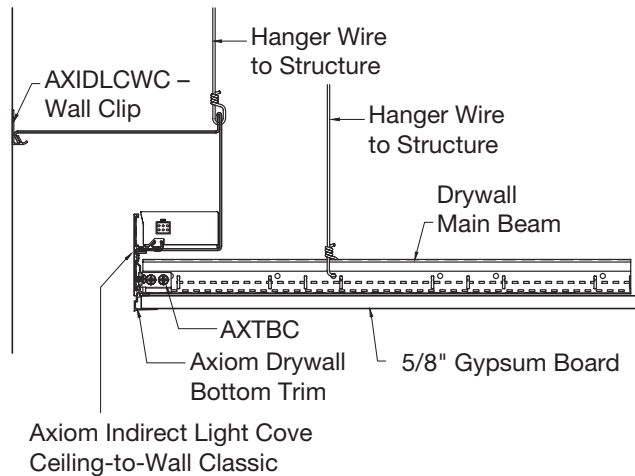

(Fig 7)

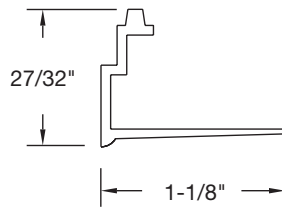

Typical Procedure

1. Attach the drywall suspension system to the light cove trim with an AXTBC clip.
2. Install Axiom bottom drywall trim (AXBTSTR).
3. Attach 5/8" drywall to the system.
4. Tape and finish drywall.
5. Paint.

Tapable Flange Installation

1. Install the moldings after the gypsum board is mounted in place.
2. Provide backing so that the moldings may be attached with #6 drywall screws 16" O.C. for horizontal applications.
3. Prior to taping, the attachment flanges should be cleaned using a non-abrasive cleaner and soft rag. When veneer plaster is specified, the flanges must be treated with a bonding agent.
4. Be sure the tape does not overlap the edge of the reveal and an 8" wide trowel is used to apply the final skim coat.

NOTE: Fiberglass self-adhesive drywall tape with a setting-type joint compound are required for joint finishing. To further ensure proper joint treatment adhesion, lightly sand the taping flange or use a bonding agent (i.e. plaster weld or spray adhesive) before applying joint compound to reduce the possibility of cracking.

3.4 Axiom Wall Clip (AXIDLCWC)

Used with Ceiling-to-Wall Indirect Light Coves (Fig 9).

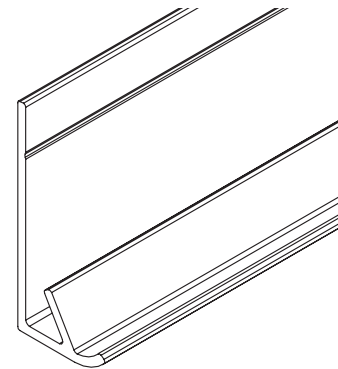

(Fig 9)

AXIDLCWC: Used to attach the ceiling-to-wall light cove to the wall.

3.5 Pre-Manufactured Corners

Available upon request. Please contact Axiom Customer Service (1 800 840-8521) for a quote.

4. GENERAL INSTALLATION INSTRUCTIONS

4.1 Axiom Light Cove Installation

The pocket is the main component of the Axiom Indirect Light Cove System. In cases where the pocket can be directly attached to the wall structure, you may need to shim to correct any irregularities (**Fig 10**).

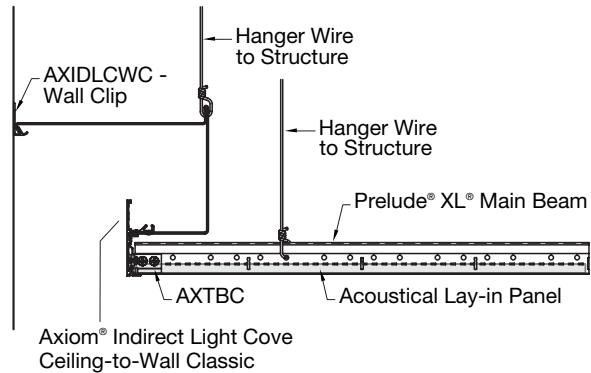

(Fig 10)

Typical Procedure for the Ceiling-to-Wall Light Cove

1. Attach AXIDLCWC wall clip to the wall structure with appropriate fasteners. Shim as required.
NOTE: It is important that the AXIDLCWC is installed flat and level, to ensure the pocket will easily attach to the light clip.
2. Pre-drill clearance holes every 16" to 24", or as needed, along the wall clip.
3. Use a laser to level the wall clip along the wall and secure it to the blocking every 16" to 24", or as required.
- 4a. The cove can be supported with 12 gauge wire as shown in the above diagram. Hanger wires should be attached to the light cove and ceiling suspension system and shall be within 12" of the light cove. Hanger wire spacing should not exceed 48".
NOTE: 20 gauge studs are required in lieu of hanger wires in Seismic Design Category D, E, F areas.
- 4b. CBS hangers can be used for NYC installations. CBS hangers shall be within 12" of the light cove.

Typical Procedure for the Ceiling to Wall Light Cove Corners

1. Attach the AXIDLCWC wall clip to the wall structure with appropriate fasteners. Use a laser to level the wall clip along the wall and secure it to blocking every 16"-24" as required, pre-drill holes in wall clip as needed. Shim as required.
NOTE: It's important that they wall clip is installed flat and level and the corner connection makes a 90 degree connection, to ensure for easy attachment.
2. The light cove can be support with 12 gauge wires attached to structure. Hanger wires shall be attached to the light cove and ceiling suspension system and shall be within 12" of the light cove.
3. The Ceiling to Wall light cove corner should be installed before the Ceiling to Wall light cove straight sections (**Figs 11 and 12**).

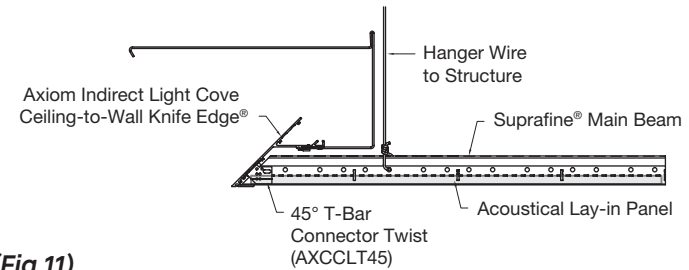

(Fig 11)

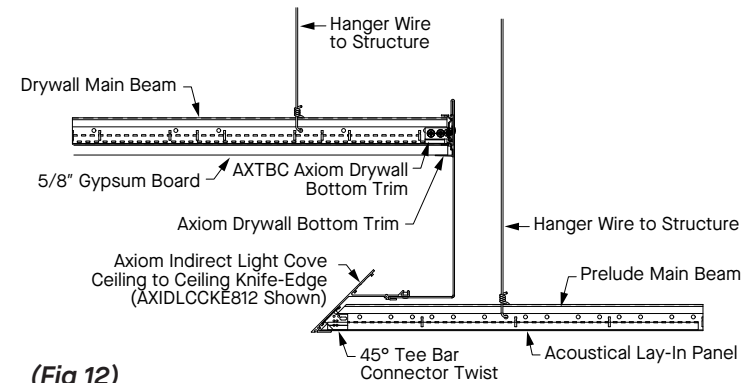

(Fig 12)

Typical Procedure for the Ceiling-to-Ceiling Light Cove

1. Pre-drill hanger holes every 48" or as required, along the top of the light cove (above the extrusion) as shown in the above drawing.
2. Hang wires to structure at least every 48".
3. Using a laser level, bend wires at the appropriate height and hang light cove. Hanger wires should be attached to the light cove and the ceiling suspension system and shall be within 6" of the light cove.

NOTE: 20 gauge studs are required in lieu of hanger wires in Seismic Design Category D, E, F areas.

Typical Procedure for the Ceiling to Ceiling Light Cove Corners

1. Pre-drill hanger holes every 48" or as required, along the top of the light cove.
2. Using a laser level, bend wires at the appropriate height and hang light cove corner. 12 gauge hanger wires should be attached to the light cove and the ceiling suspension system.
3. The Ceiling to Ceiling light cove corners can be installed before or after the Ceiling to Ceiling light cove straight sections, dependent on field conditions.

5. INSTALLING COMPATIBLE LIGHT FIXTURES

Axiom® Indirect Light Coves are designed to work exclusively with Axis CovePerfekt™, Litecontrol ACOVE15AL, or Vode® ZipWave™ | LED | 707 light fixtures only. Slots are provided in the cove to accommodate the light fixture wiring. Please refer to the lighting manufacturer's specific installation instructions for details on light installation.

NOTE: A key notch is located in the cove and the compatible lighting fixture to ensure proper alignment (**Fig 13**).

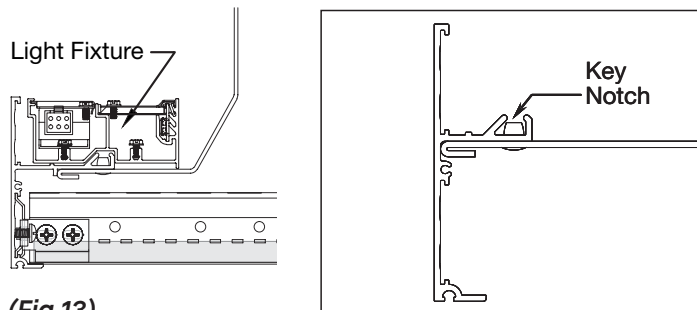

(Fig 13)

5.1 Attaching to Suspension System

Axiom Indirect Light Coves are installed before acoustical or drywall suspension systems. Most acoustical and drywall systems will attach directly to the light cove. There are several options for the Axiom connector clip used to attach the suspension system to the cove. Carefully review these options based on the systems you are installing (**Fig 14**).

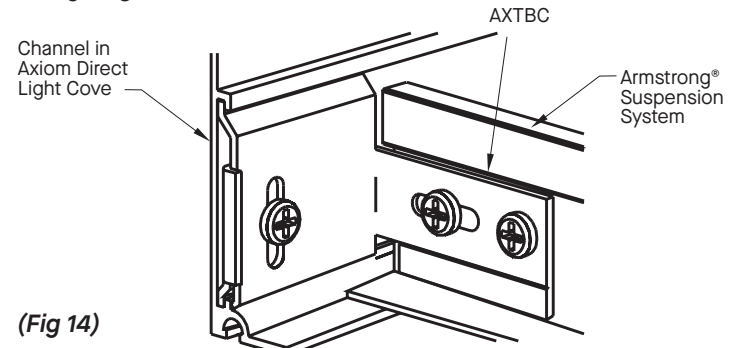

(Fig 14)

Typical Procedure

1. Refer to the reflected ceiling plan for the suspension system layout.
2. Determine the size of the border panel next to the Axiom Light Cove.
3. Install the suspension system so it will rest 3/8" on the light cove flange.
4. Select the correct Axiom T-Bar Connector Clip (AXTBC or AXCCLT45) for your suspension system (AX-V-TBC Connector Clip should be used with cut Vector® border panels or AXCCLT45 for use with Axiom® Knife Edge® Light Cove profiles).
5. Rest the bottom of the clip on the flange of the suspension system.
6. Attach the clips by aligning the end of the elongated hole 1/4" from the cut end of the suspension system and inserting a standard framing screw into the center of the slot.
7. Use a Phillips screwdriver to loosen the locking screw on the lower plate.
8. Engage the top ear of the connector clip under the boss of the cove channel trim. Slide the lower leg downward to engage the lower boss on the trim and secure by tightening and locking the screw.
9. Loosen the locking screw and adjust the clip as necessary to properly align the suspension system.
10. Insert a second framing screw through the other hole in each of the connector clips.

5.2 Axiom® Connector Clip Options

5.2.1 Prelude® XL® and Suprafine® T-Bar suspension systems will rest on the lower flange of the light cove. Prelude and Suprafine suspension systems are used with flat lay-in and some Tegular applications. For a T-Bar suspension system that will rest on the lower flange of the Axiom trim, use AXTBC Connector Clip.

5.3 Silhouette® XL®, Interlude® XL® HRC, and Sonata® XL® (systems with 5/16" shoulder height) will require the clip to be modified to be held 1/4" above the light cove flange. Modify the clip by cutting 1/4" off the bottom of the clip at the score line. This can be done with a regular pair of snips.

Silhouette XL, Interlude XL HRC, and Sonata XL suspension systems (with a 5/16" shoulder height), use Tegular panels with the panel face resting on the trim flange, and 5/8" concealed tile – use AXTBC Connector Clip.

6. AXIOM INDIRECT LIGHT COVE COMPONENT SUPPORT

The manufacturer requires the Axiom Light Cove and ceiling suspension system be installed and supported in a manner that complies with all applicable codes and standards.

7. INSTALL CEILING PANELS, TILE, OR DRYWALL

7.1 Cut and install tiles or panels using standard procedures for the products specified.

7.2 Treat exposed cut edges of ceiling panels as detailed in the product specifications.

7.3 For drywall applications, attach 5/8" gypsum to the suspension system per the manufacturer's recommendations.

8. FINAL DETAILING

7.1 Check and adjust the alignment of the suspension system and ceiling panels.

8.2 Clean exposed surfaces as required. Painted Axiom® components may be wiped down with rubbing alcohol or a mild soap solution to remove fingerprints, oil, etc.

8.3 Touch up painted components as required. All painted custom Axiom shipments include a container of paint to be used for touch-up.

9. SEISMIC INSTALLATION

9.1 Axiom Indirect Light Coves and Axis CovePerfekt™, Litecontrol ACOVE15AL, and Vode® ZipWave™ | LED | 707 light fixtures are all suitable for Seismic Design Category D, E, F installations.

Ask your Armstrong Installation Specialist for bracing requirements.

MORE INFORMATION

For more information, or for an Armstrong Ceilings representative, call 1 877 276-7876.

For complete technical information, detail drawings, CAD design assistance, installation information, and many other technical services, call TechLine customer support at 1 877 276-7876 or FAX 1 800 572-TECH.

All trademarks used herein are the property of AWI Licensing LLC and/or its affiliates.
© 2023 AWI Licensing Company Printed in the United States of America

BPLA-298255-923



Armstrong[®]
World Industries