

# Axiom<sup>®</sup> Indirect Light Ledge

## Assembly and Installation Instructions

### 1. GENERAL

#### 1.1 Product Description

The Axiom<sup>®</sup> Indirect Light Ledge system is a pre-engineered lighting solution designed to be used at a full height wall condition or a drywall furdown and integrates with a 5/8" drywall board. The system consists of an extruded piece of aluminum, and is designed to integrate with Armstrong<sup>®</sup> Drywall Grid and drywall to create the vertical leg of the light ledge. The ledge is designed with or without a notched channel. The notched channel allows for perfect integration with Axis Lighting, or Vode<sup>®</sup> Lighting. Keyless and curved light ledges do not have key notches and lights must be placed independently.

**NOTE:** Axiom Indirect Light Ledge is designed to integrate with Axis CovePerfekt™ or Vode<sup>®</sup> ZipWave™ | LED | 707 light fixtures only. All figures in these instructions are depicting the notched channel fixtures only.

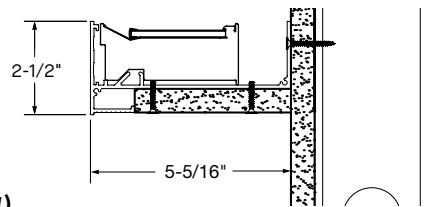

(Fig 1)

#### Component Description: Axiom Indirect Light Ledge:

Extruded aluminum light ledge is designed to integrate with 5/8" drywall board, and forms an indirect light ledge with distinct architectural features that can be attached to a full height wall or a drywall furdown. Special bosses are provided along with AX4SPlice splice plates to connect and provide positive attachment with no visible fasteners. There are two profile designs with face edge options to accommodate full height wall or drywall furdown transitions. The Knife Edge<sup>®</sup> trim and 2" Classic Drywall Trim options can only be ordered with a drywall flange option.

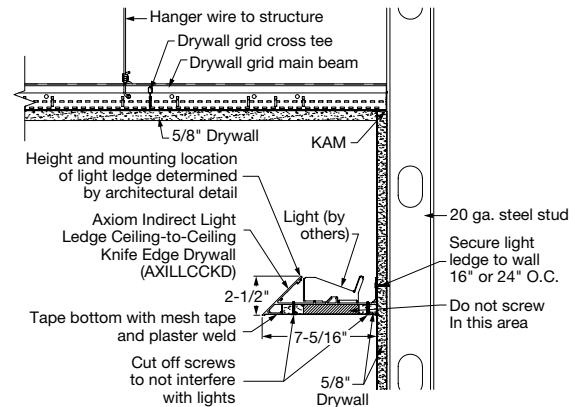

(Fig 2)

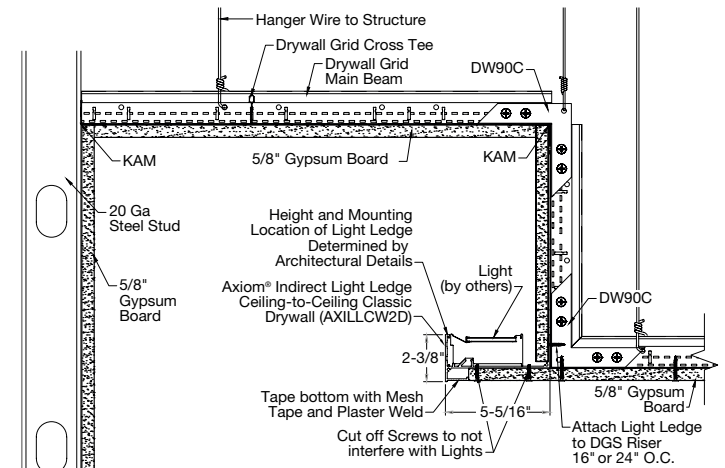

(Fig 3)

Axiom® Indirect Light Ledge Corners can be ordered in both the Knife Edge® trim and 2" Classic drywall trim for both Ceiling-to-Wall and the Ceiling-to-Ceiling conditions as well as keyless options. The pre-made, factory-finished inside and outside corners are made to match the trim option of the straight or curved Axiom trim sections. Each corner section is 12" × 12" square (dimension taken on the face of the extrusion) (**Fig 4**) (**Fig 5**).

Axiom Indirect Light Ledge End Plates can be ordered in both the Knife Edge and 2" Classic drywall trims for both the Ceiling-to-Wall and the Ceiling-to-Ceiling conditions. The pre-made factory-finished end plates are made to match the trim option of the straight Axiom sections (**Fig 6**).

## 2. MATERIAL DELIVERY AND IDENTIFICATION

Axiom Indirect Light Ledges are packaged and delivered in the quantities ordered. All hardware and instructions for assembly are included in the packaging. Custom projects may include shop drawings as well. Identify all parts listed in the drawings and verify they are delivered to the site before starting the installation. Exercise care to protect the finished surfaces of the trim.

## 3. COMPONENT ASSEMBLY

### 3.1 Splice Plates

Steel splice plates are used to align and secure joints between sections of the Axiom Indirect Light Ledge. Each joint requires a splice plate at every set of bosses for proper trim alignment. Join straight sections of cove together using the AX4SPlice splice plate. Splice plates are secured to the trim sections using factory-installed set screws. A 1/8" hex key is included with the hardware (**Fig 7**).

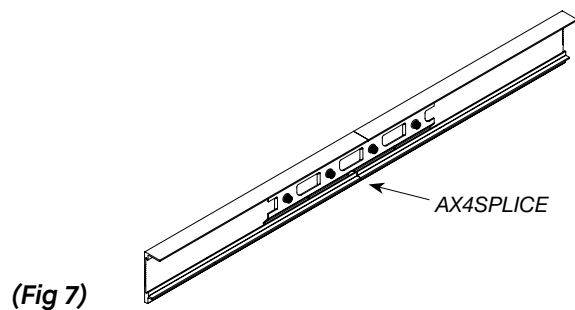

**NOTE:** Splice plates can slide completely into the channel bosses and then slide into the adjoining section after the ledge is aligned. This will aid splice plate connections for the last piece.

### Knife Edge® Corners: (Fig 4)

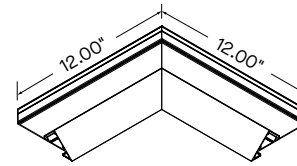

Knife Edge® Ceiling-to-Wall  
Inside Corner

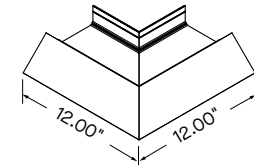

Knife Edge Ceiling-to-Wall  
Outside Corner

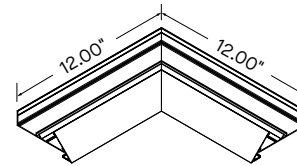

Classic Ceiling-to-Wall  
Inside Corner

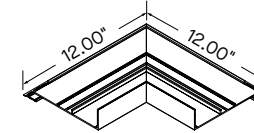

Classic Ceiling-to-Wall  
Outside Corner

### Classic Corners: (Fig 5)

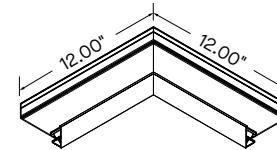

Knife Edge Ceiling-to-Ceiling  
Inside Corner

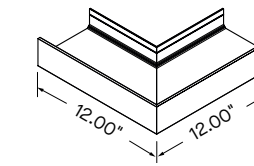

Knife Edge Ceiling-to-Ceiling  
Outside Corner

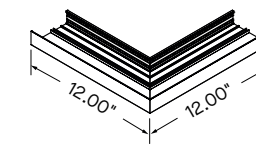

Classic Ceiling-to-Ceiling  
Inside Corner

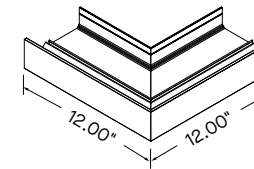

Classic Ceiling-to-Ceiling  
Outside Corner

### End Plates: (Fig 6)

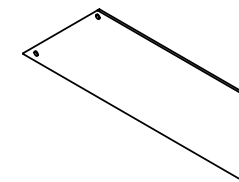

Knife Edge End Plate

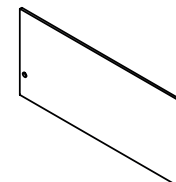

Classic End Plate

## 4. GENERAL INSTALLTION INSTRUCTIONS

### 4.1 Axiom® Indirect Light Ledge Installation

The Axiom pocket is the main component of the Axiom Indirect Light Ledge System.

#### Typical Procedure for the Axiom Indirect Light Ledge:

1. Install the full height wall or drywall furdown as noted on the architectural drawings and details. **NOTE:** Wall and/or drywall furdown may be installed by other trades.
2. The Axiom Indirect Light Ledge is designed for integration with 5/8" drywall board. **NOTE:** 5/8" drywall can be installed before or after the Axiom Indirect Light Ledge is attached to either the drywall furdown or the full height wall.
3. Using a laser level, install the Axiom Indirect Light Ledge product against the vertical full height wall or vertical drywall furdown.
4. Screw-attach the Axiom Indirect Light Ledge to the drywall furdown or the full height wall every 16" or 24" O.C. using single point screws to attach the ledge to the wall studs or drywall grid components. The back of the Axiom Indirect Light Ledge should sit tight against the drywall furdown vertical rise or drywall vertical wall. **NOTE:** The back of the Axiom Indirect Light Ledge has a score line to allow for easier screw attachment and placement.
5. AX4SPICE plates should be used to attach multiple sections of the Axiom Indirect Light Ledge together. This will ensure the face of the cove is level and minimize the gaps in the finished product.
6. Install drywall board against the bottom of the Axiom Indirect Light Ledge using single point attachment screws. Install mesh tape, mud, sand, and apply paint to drywall as required to finish vertical and horizontal sections of the Axiom Indirect Light Ledge per architectural specifications.
7. Please note the location where the screws are installed, as they may affect the placement and leveling of the compatible lighting fixtures. If screws interfere with the lighting fixture, the tips of those screws should be removed with wire cutters or machine tools, as required.
8. Axiom Indirect Light Ledges are shipped in 10' straight lengths, as 12" x 12" corners, end returns, and end plates. Straight length of the Axiom Indirect Light Ledge can be cut to size in the field using a 12" compound miter saw.

## 5. INSTALLING COMPATIBLE LIGHT FIXTURES IN KEY NOTCH LEDGES

Axiom Indirect Light Ledges with key notch are designed to work exclusively with Axis CovePerfekt™ or Vode® ZipWave™ | LED | 707 light fixtures. Slots are provided to accommodate the light fixture wiring. Please refer to the lighting manufacturer's specific installation instructions for details on light installation.

**NOTE:** A key notch is located in straight sections of the Axiom Indirect Light Ledge and in the compatible lighting fixture to ensure proper alignment. Curved sections do not have key notches, and lights must be placed independently.

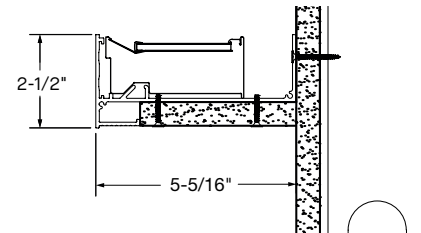

(Fig 8)

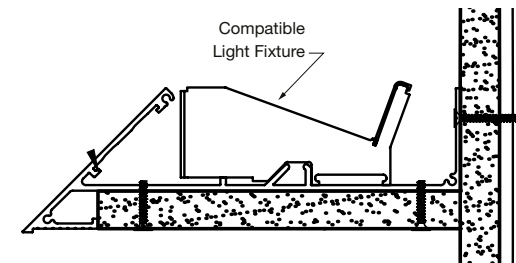

(Fig 9)

#### Tapable Flange Installation:

1. Install the moldings after the gypsum board is mounted in place.
  2. Provide backing so that the moldings may be attached with #6 drywall screws 16" O.C. for horizontal applications.
  3. Prior to taping, the attachment flanges should be cleaned using a non-abrasive cleaner and soft rag. When veneer plaster is specified, the flanges must be treated with a bonding agent.
  4. Be sure the tape does not overlap the edge of the reveal and an 8" wide trowel is used to apply the final skim coat.
- NOTE:** Fiberglass self-adhesive drywall tape with a setting-type joint compound is required for joint finishing. To further ensure proper joint treatment adhesion, lightly sand the taping flange or use a bonding agent (i.e. plaster weld or spray adhesive) before applying joint compound to reduce the possibility of cracking.

## 6. FINAL DETAILING

**6.1** Examine and adjust the alignment of the Axiom® Indirect Light Ledge.

**6.2** Clean exposed surfaces, as required. Painted Axiom components may be wiped down with rubbing alcohol or a mild soap solution to remove fingerprints, oil, etc.

**6.3** Touch up painted components, as required. All painted custom Axiom shipments include a container of paint to be used for time of use.

## 7. SEISMIC INSTALLATION

**7.1** Axiom Indirect Light Coves, Axis CovePerfekt™ and Vode® ZipWave™ | LED | 707 light fixtures are all suitable for Seismic Design Category D, E, F installations.

Ask your Armstrong Installation Specialist for bracing requirements.

---

### MORE INFORMATION

For more information, or for an Armstrong Ceilings representative, call 877 276-7876.

For complete technical information, detail drawings, CAD design assistance, installation information, and many other technical services, call TechLine customer support at 877 276-7876 or FAX 800 572-TECH.

CovePerfekt™ is a trademark of Axis Lighting; Vode® and ZipWave™ are trademarks of Vode Lighting LLC; Compose™ is a trademark of i2Systems  
All other trademarks used herein are the property of AWI Licensing LLC and/or its affiliates.  
© 2024 AWI Licensing Company Printed in the United States of America

BPLA-299059-524



**Armstrong**<sup>®</sup>  
World Industries