

# CONTINUOUS LOAD PATH Suspension System – Data Center Ceiling Solutions

## Assembly and Installation Instructions

**NOTE: 3/8" or 1/2" threaded rods are purchased separately. Hardware for use with 1/2" threaded rod will need to be purchased separately.**

### 1. SYSTEM OVERVIEW

The CLP7301 is designed to offer high strength support of cable trays, bus bars, hot and cold aisle containment, and other hanging elements via a 3/8" or 1/2" threaded rod connections directly to deck.

**IMPORTANT:** The Continuous Load Path Clip item (CLP7301) is designed to be used with Prelude® XL® Suspension System only. It is designed and tested specifically for integration with Prelude XL Suspension System. Armstrong is not liable for improper use or improper installation of the Continuous Load Path or suspended components.

The Continuous Load Path is a 6" main beam component that integrates with our standard Prelude XL system. It allows for a main beam to be replaced with the Continuous Load Path insert (CLP7301) and new special sized main beam (7396 or 7376) that stab into the existing system, creating a pathway for the threaded rod to pass through the ceiling plane without unwarranted air penetrations in the ceiling grid or tiles. None of the load on the threaded rod is transferred to the ceiling system, thus enabling data centers to support point loads in excess of 1000 pounds via the threaded rod, as well as providing an economical solution because it integrates with our standard Prelude XL suspension system. Typical 3/8" threaded rod has an allowable tension load rating up to 1,800 lbs and typical 1/2" threaded rods have allowable tension load ratings up to 3,300lbs making this solution.

Contact your local Armstrong representative for other usage areas with CLP7301 clip such as lighting, signage and other applications where threaded rods interrupt the ceiling panels.

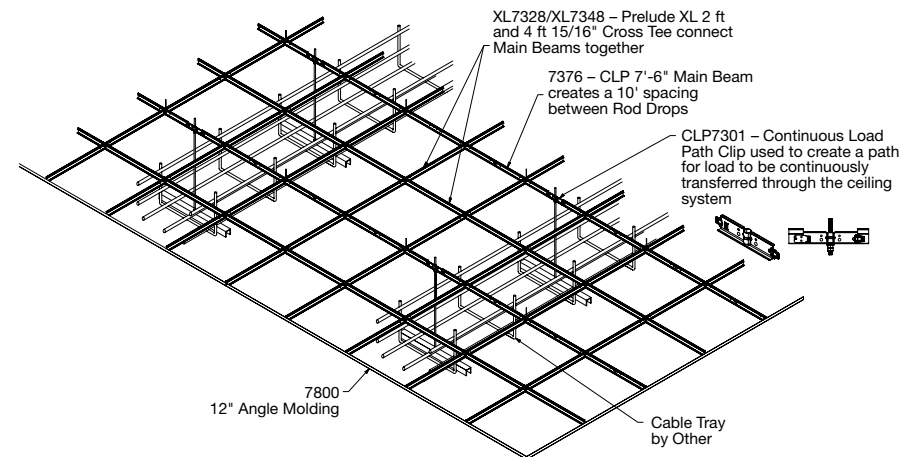

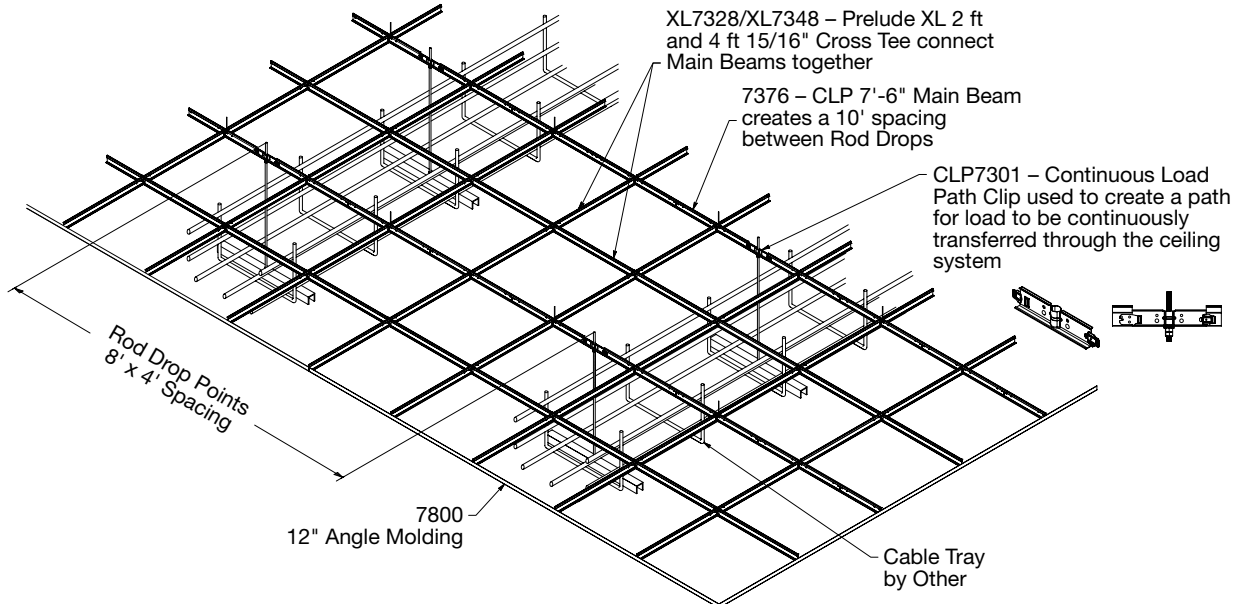
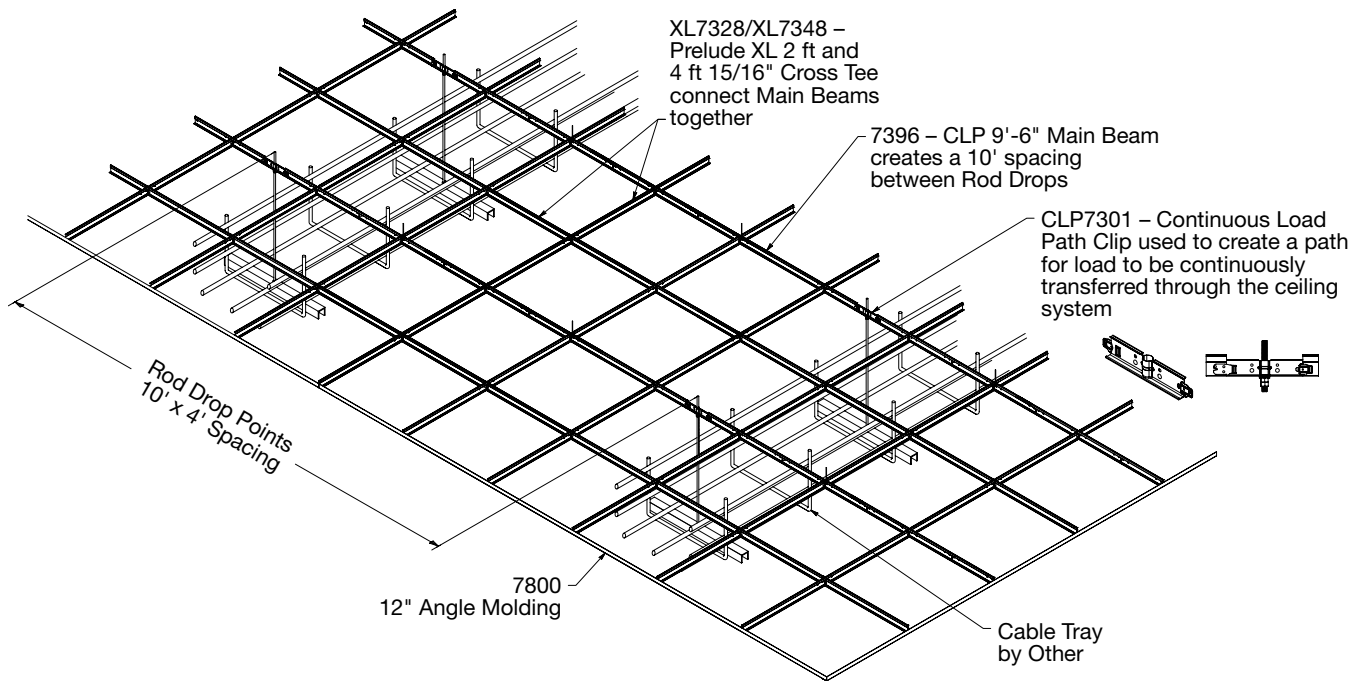

## 2. INSTALLATION CONSIDERATIONS

The Continuous Load Path Clip (CLP7301) is designed to be installed on either a 3/8" or 1/2" threaded rod connection to deck. Hanger wires can be used to hang this system if threaded rods are not available at time of installation.

**2.1.** Lay out the space, marking the locations of the hanger rods, hanger wires, Main Runners, Cross Tees, and Continuous Load Path Clips, and note any mechanicals that will be supported overhead. 8 FT O.C. and 10 FT O.C. are standard configurations. When used with the 6" insert component (CLP7301), the 9'6" main beam (7396) is for 10' rod centers and the 7'6" main beam (7376) is for 8' rod centers for typical data hall on center layouts. Custom module/layout sizes can be requested through our specials line.

**NOTE: THREADED ROD DROP LOCATIONS ARE CRITICAL IN LOW PLENUM SITUATIONS (<6 FT OF PLENUM). THREADED ROD LAYOUT IS CRITICAL TO MAINTAIN A CONSISTENT LAYOUT. TRADE COORDINATION, LAYOUT AND SEQUENCE OF CONSTRUCTION REQUIRED PRIOR TO INSTALLATION.**

Threaded rod location tolerance should be discussed before crew begins installing.

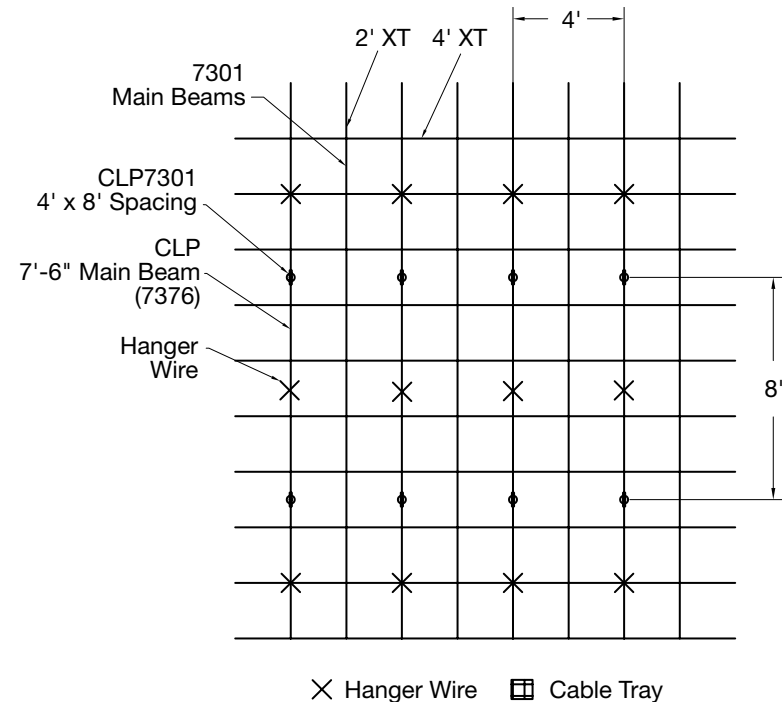
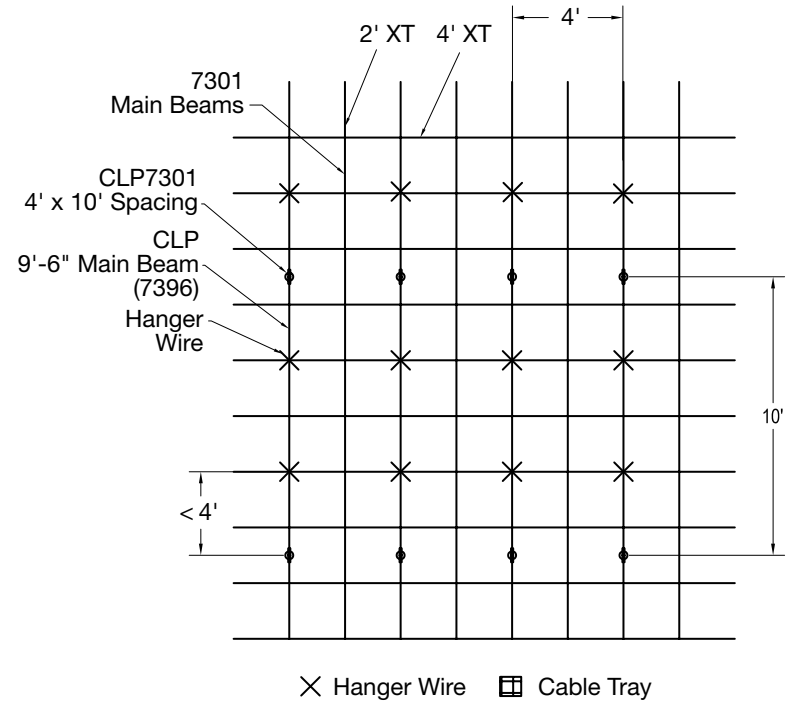

**2.2.** Install the Wall Angle. Screw attach all angle to wall with #8 truss head, self-tapping screws.

**2.3.** Install may allow the threaded rods to be installed first. Supporting the CLP7301 Clip using threaded rods is required for seismic installations. Install threaded rods and hanger wires to the deck. Slide the CLP7301 Clip up the threaded rod. Place grommet, washer, and two nuts under the CLP7301 Clip to achieve proper elevation.

**NOTE:** Nuts, washers, and grommet provided with the clip, when properly installed, reduce airflow to and from the plenum. Not using this hardware could result in reduce performance of the clip.

**NOTE:** Hardware provided with the CLP7301 Clip is for 3/8" threaded rod. Hardware includes nuts (MSC item# 87921425), washers (MSC item# 87925384), and grommets (Grainger item# 4PAD6). Clip will work with 1/2" threaded rod also, but nuts washers, and grommets will need to be purchased separately.

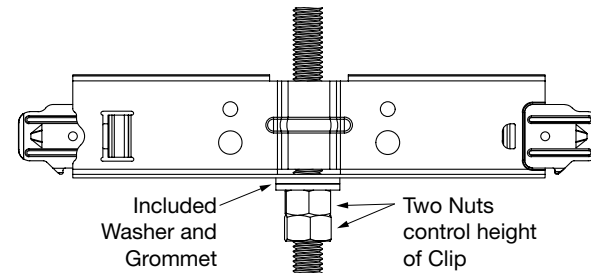
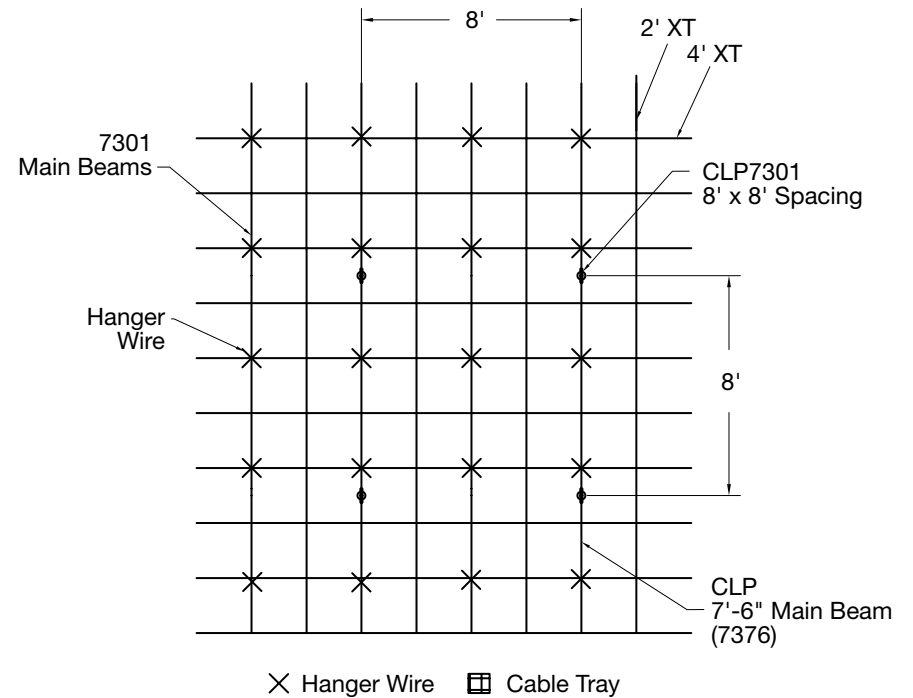

*In cases where additional bracing is required, it may be acceptable to support the CLP7301 Clip using hanger wires*

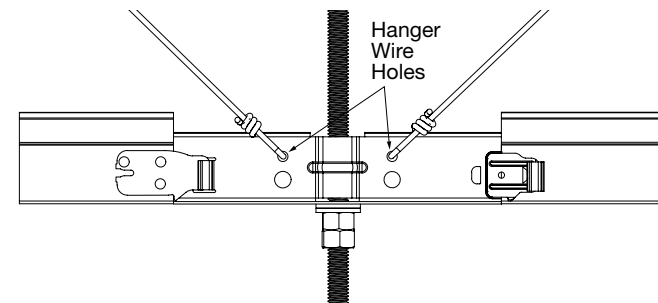

**2.4.** Attach main runners to the CLP7301 clip on either side and support the main runners within 4' of the connection with the CLP7301 Clip. Depending on module size, main beams may need more than 1 support. When leveling ceiling, CLP7301 height can be adjusted using a nut below the clip and adding a second nut acting as a jam nut when CLP7301 is at the desired height.

**2.5.** Due to trade coordination/sequence of construction, the threaded rods may not be available before the ceiling install. In this case the CLP7301 can be hung without threaded rods. An additional hanger wire can be added to one side of the CLP7301 clip as a support. Install main beams using hanger wires. Hanger wire spacing will be no more than 48" apart. Attach CLP7301 to the CLP main beam ends, connecting adjacent mains together. Each main beam must be supported within 3" of a splice and within 3" of the CLP7301 connection.

Example: Trade coordination: Ceiling can be hung by hanger wires by the ceiling contractor. The electrical contractor can hang the threaded rod and then would finish the CLP7301 off by installing the washer, grommet and two nuts that seals off the ceiling.

**NOTE:** Nuts, washers, and grommet provided with the clip, when properly installed, reduce airflow to and from the plenum. Not using this hardware could result in reduce performance of the clip.

**2.6. NOTE:** CLP7301 can be hung using hanger holes.

**2.7.** Install cross tees the same as a standard ceiling system.

**2.8.** Final leveling – In applications which allow the clip to rest on the grommet, washer, and nuts, the CLP7301 height can be adjusted using the nut below the clip and using the second nut acting as a jam nut when CLP7301 is at the desired height. Ensure the double nuts are locked together to prevent movement. Applications that utilize hanger wires can be leveled using the hanger wire itself.

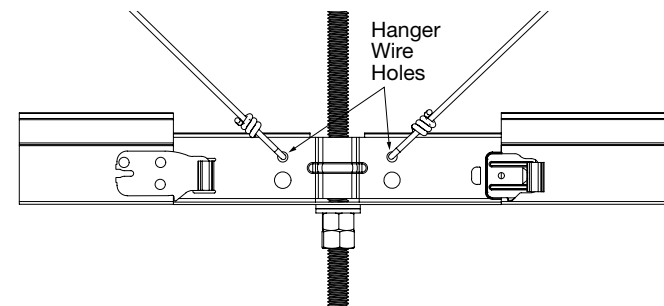
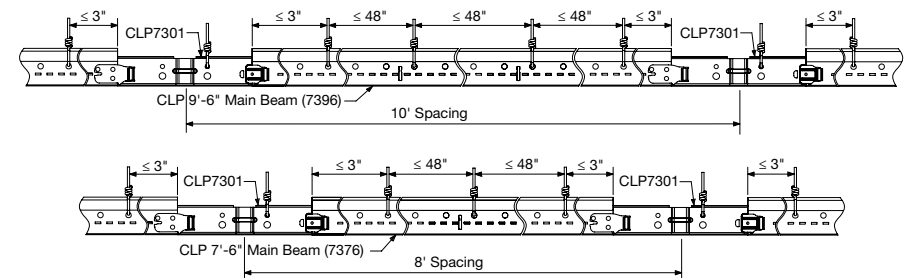
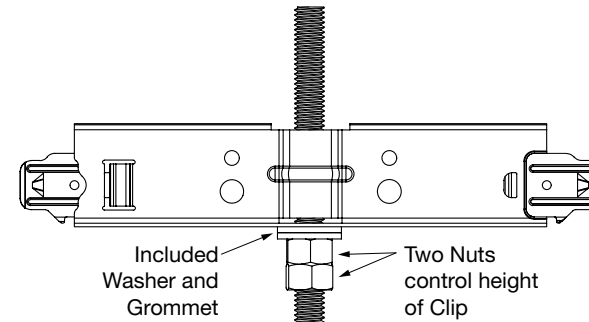
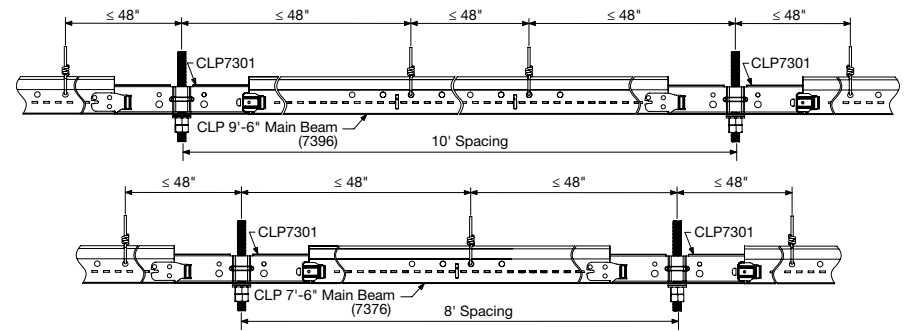

**2.9.** When plumb threaded rod drops are not possible, then a trapeze or sub framing may be required. This sub or trapeze framing must be engineered to support the designed loads.

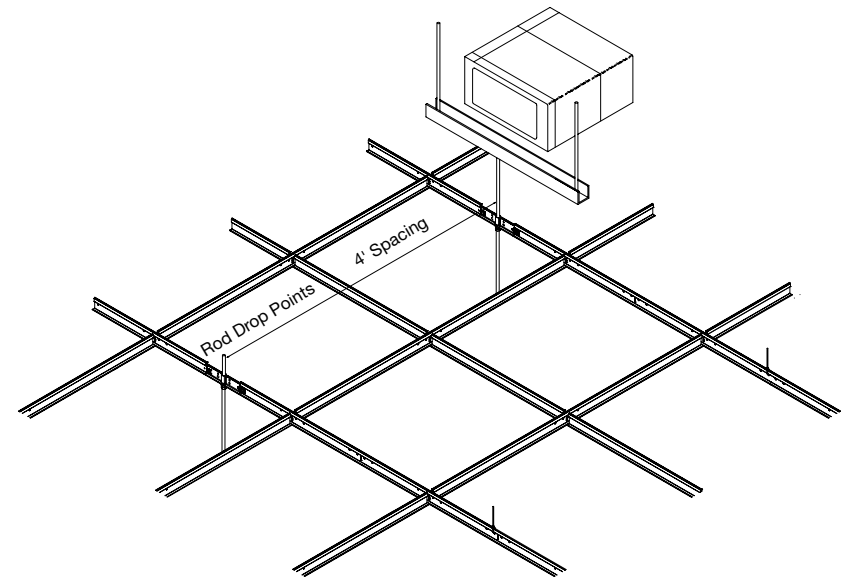
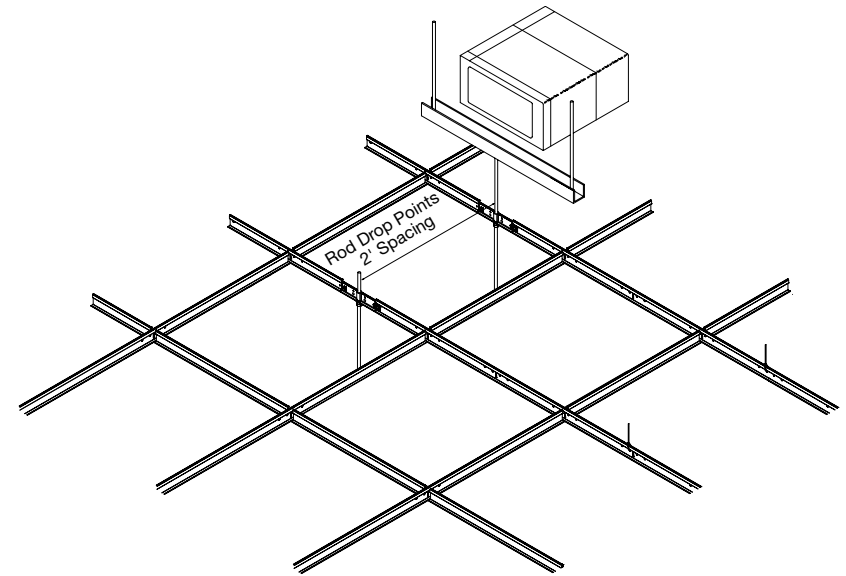

#### **MORE INFORMATION**

For more information, or for an Armstrong Ceilings representative, call 1 877 276 7876.

For complete technical information, detail drawings, CAD design assistance, installation information, and many other technical services, call TechLine customer support at 1 877 276 7876 or FAX 1 800 572 TECH.

Inspiring Great Spaces® is a registered trademark of AFI Licensing LLC; All other trademarks used herein are the property of AWI Licensing LLC and/or its affiliates.

© 2020 AWI Licensing Company Printed in the United States of America

**Armstrong**<sup>®</sup>  
CEILING & WALL SOLUTIONS