

# DesignStackz™ Ceiling System

## Assembly and Installation Instructions



### 1. GENERAL

This system is unique to the ceilings industry. Please completely read all instructions before beginning installation to avoid potential re-work.

#### 1.1 Product Description

The panels referenced in these installation instructions are made from mineral fiber. The panels feature an acoustically transparent membrane with a smooth white latex paint surface finish. The panels have a tegular edge design to install on 9/16" Suprafine® suspension system (Fig 1).

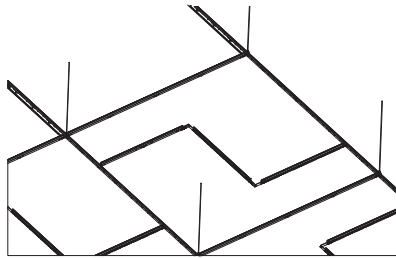

(Fig 1)

**NOTE:** It is not recommended to mix these panels with Armstrong® DesignFlex® panels, as their colors do not coordinate.

#### 1.2 Storage and Handling

Panels should be installed in a dry interior location and remain in cartons in a flat position to avoid damage. Proper care should be taken when handling to avoid damage or soiling.

#### 1.3 Site Conditions

Areas of installation should be free of construction dust and debris. Products with HumiGuard® Plus performance can be installed in conditions between 32°F (0°C) and 120°F (49°C) and in spaces before the building is enclosed, where HVAC systems are cycled or not operating. These products are not recommended for exterior applications, or where standing water is present, or where moisture will come in direct contact with the ceiling.

#### 1.4 Fire Performance

DesignStackz™ panels are tested to ASTM E84 and CAN/ULC S102 surface burning characteristics. Flame Spread Index 25 or less. Smoke Developed Index 50 or less (UL® labeled).

#### 1.5 Safety Considerations When Working with Fiberglass and Mineral Fiber Products Precautionary Measures

During the installation, be certain that the worksite is well ventilated, and avoid breathing dust. If high dust levels are anticipated during installation, such as with the use of power tools, use appropriate NIOSH-designated dust respirator. All power cutting tools must be equipped with dust collectors. Avoid contact with skin or eyes.

First Aid Measures: If contact occurs, flush eyes and skin irritation with plenty of water for at least 15 minutes, and remove contaminated clothing. Wash work clothes with warm water and mild soap. Refer to Armstrong World Industries SDS (which includes information on established occupational exposure limits), available at [armstrongceilings.com/commercial](http://armstrongceilings.com/commercial)

##### 1.5.1 Important Safety Information

- This is a custom design and installation.
- This product can't be installed in a sloped application.
- The final design and installation parameters are the responsibility of your design team.
- Project specific evaluation for compliance with building codes is recommended.
- All information provided pertains solely to Armstrong® DesignStackz ceilings and components. Any ceiling panel, grid, component, or accessory substitutions are not covered by these instructions or warranty.

## 1.6 Cleaning

Dust and loose dirt can easily be removed by brushing or with a vacuum cleaner. For best results, use vacuum cleaner brush attachments such as those designed for cleaning upholstery or walls. Be certain to clean in one direction only. This will prevent rubbing dust into the surface of the ceiling. Use a clean, dry, soft, white cloth to wipe off any dirt or greasy fingerprints. If this does not clean the panel, use a damp, clean, soft, white cloth, or sponge with a mild detergent to wipe the panel. Remove any remaining moisture with a dry cloth.

## 1.7 Ordering consideration

Product is dye-lotted. Order sufficient initial quantities and attic stock to minimize possible color variation.

## 2. DESIGN & INSTALLATION CONSIDERATION

### 2.1 Layout

This system is designed to build off of a 4' on center (O.C.) spacing of standard 9/16" Suprafine® main beams. Refer to your job-specific drawings for layout and specific component as well as architectural ceiling plan for suspension system panel orientation layout.

### 2.2 Directionality

#### 2.2.1 Suspension System

The suspension system must be installed in accordance with the architectural ceiling plans. While the main beams and 4' Cross Tees are non-directional, there are two types of 2' Cross Tees for use with this system, one of which has different end details and is directional. Refer to Section 3 for additional information.

#### 2.2.2 Panels

There are two DesignStackz™ panel designs (left and right) (*Figs 2 & 3*) and each design will dictate the placement of the Cross Tees within a 4' x 4' grid module to create the grid opening for the panel. The panel design permits a 180-degree rotation, and two identical panel designs are snugly nested within a 4' x 4' module (*Fig 4*).

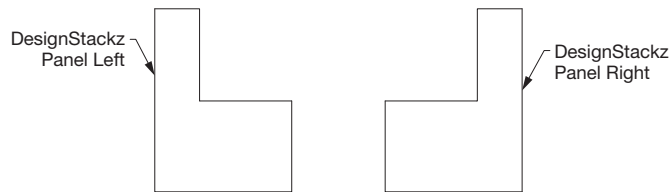

(Fig 2)

(Fig 3)

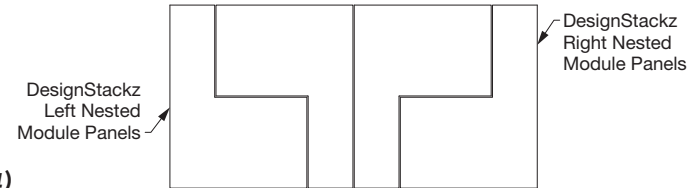

(Fig 4)

### 2.3 Panel Offset

The finish face of the tegular panel drops 1/4" below the face of the grid (*Fig 5*).

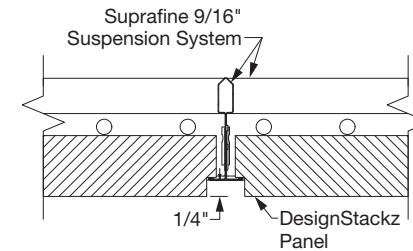

(Fig 5)

The installed height of components that interface with these ceiling panels, such as sprinkler heads and light fixture trim rings, will have to be adjusted to accommodate this 1/4" offset.

### 2.4 Plenum

Installation of DesignStackz panels requires a minimum of 18" of space in the plenum.

NOTE: Light fixtures and air handling systems may require more space and may determine the minimum plenum height for the installation.

### 2.5 Integration of MEP

Independent support of MEP devices is required. Weight from any lights, diffusers, speakers, or similar devices may not be supported by the DesignStackz panels or suspension system. All such devices must be independently supported.

Due to the non-standard grid openings that are created for the DesignStackz system, some standard fixtures may not be compatible or may require modifications to the system. For details on fixture integration through TechZone® ceiling panel layouts, and integration partners, see Section 7.

## 2.6 Slope Ceilings & Exterior Installation

This product cannot be installed in a slope or in exterior applications.

## 2.7 Accessibility

Full-size panels without penetrations are accessible. Border panels may not be accessible based on the perimeter interface and the installation method.

## 2.8 Perimeters

Perimeter treatments depend on the specific design and layout of the space. For further details on handling cuts at perimeters, refer to Section 5.

## 2.9 Estimating

For guidance on estimating installed costs, contact your Armstrong Ceilings Sales Rep.

## 3. SUSPENSION SYSTEM – WALL-TO-WALL

The requirements listed here represent the manufacturer's minimum acceptable installation recommendations and may be subject to additional requirements established by the local authority having jurisdiction.

- All installations should follow ASTM C636
- All references to suspension component duty ratings are per ASTM C635

### 3.1 System Component

#### 3.1.1 Main Beam

DesignStackz™ panels install on Intermediate-duty Suprafine® main beams.

See Section 8 for grid requirements in seismic installations.

#### 3.1.2 4' XL Cross Tee

Standard 4' Cross Tee is required for the DesignStackz layout, and it must be intermediate-duty equivalent (12 LBS./LF) or greater and must be the same height as the main beams (1-11/16").

#### 3.1.3 XM Cross Tee

These Cross Tees are made to specific lengths and feature an XM stab-end detail on both ends for connection to 90-degree angle brackets (**Fig 6**). A 12-gauge Hanger Wire (Item 7891) is required to support the middle of the XM Cross Tee.

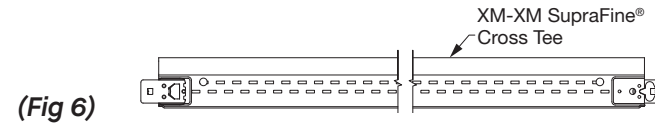

(Fig 6)

#### 3.1.4 XL/XM Cross Tee

These Cross Tees are made to specific lengths and feature two different stab-end details. One side has an XM stab-end detail for connection to the 90-degree angle bracket and the other has an XL stab-end detail for connections to a standard 4' Cross Tee or main beam (**Fig 7**).

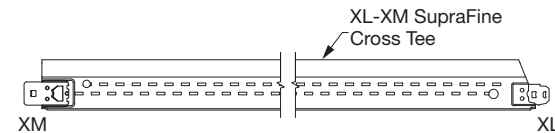

(Fig 7)

#### 3.1.5 90-degree Angle Bracket

The 90-degree angle brackets feature an XM stab-end detail and are used to set the angles of the special length XM Cross Tees and the XL/XM Cross Tee. These brackets are installed within a 4' x 4' grid module, in specific locations based on the DesignStackz panel being installed (**Fig 8**).

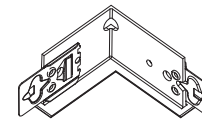

(Fig 8)

#### 3.1.6 STAC Clip (Single Tee Adapter Clip)

Depending on the panel design or orientation, a single Cross Tee may occupy a rout hole. These single Cross Tee connections must be reinforced to meet code requirements for connection strength. Armstrong requires using the Single Tee Adapter Clip (STAC Clip) (**Fig 9**).

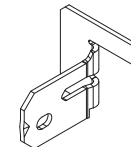

(Fig 9)

### 3.2 Suspension Rules

- Main beams must be installed at 48" O.C. per the layout drawing, and never exceed 48" O.C.
- Hanger wires must be installed on the mains within 24" of the perimeters and no more than 48" O.C. along the mains.
- 4' Cross Tees must intersect the main beams at 90 degrees every 48" O.C, creating a 4' x 4' grid module.
- A 12-gauge Hanger Wire must be installed at the midpoint of each XM tee. Regardless of panel design and orientation, the wire will be located at the center of the 4' x 4' module.

### 3.3 Layouts

The grid layout will be based on the DesignStackz™ ceiling design and the architectural ceiling plans/technical drawings layouts. However, all possible layouts work off a 4' main beam spacing. To determine the grid layout specific to your project, please consult the project drawings. (Figs 10 & 11)

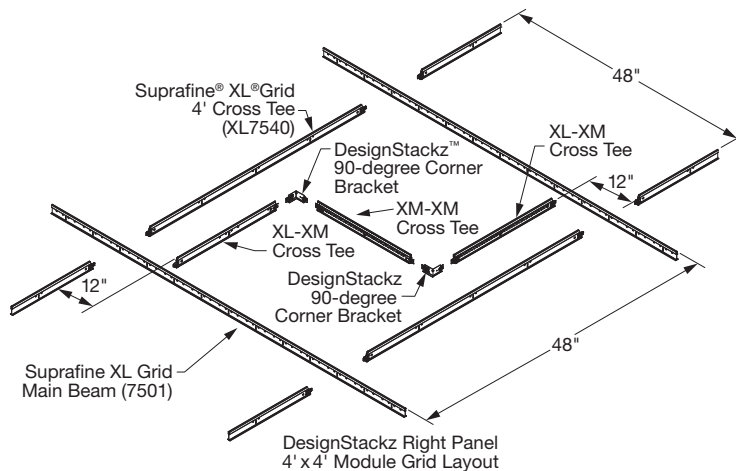

(Fig 10)

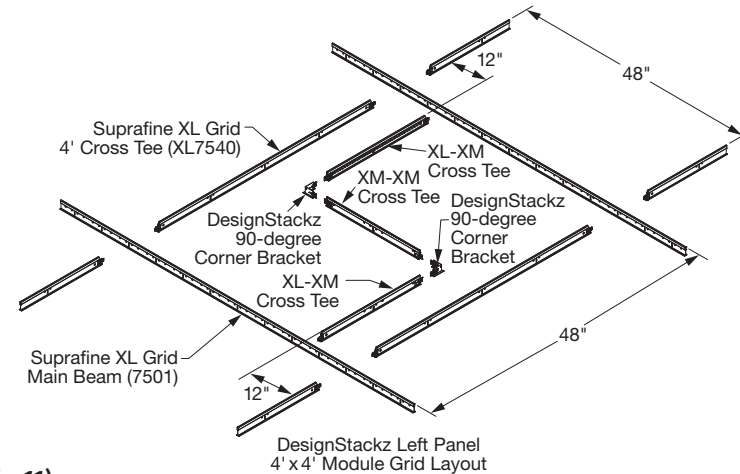

(Fig 11)

### 3.4 Squaring and Leveling the Grid

DesignStackz panel installations can be leveled and squared by traditional means by measuring the 4' x 4' grid module. Alignment of the grid to the dry lines must be within 1/16" over 12'. Once the 4' x 4' grid module is square, Cross Tees and angle brackets are added within the 4' x 4' grid opening to create the grid shape for the DesignStackz panels.

**NOTE:** To achieve a plumb and level installation within each 4' x 4' module, it is recommended to tighten the required hanger wire attached to the XM tee after installing one of the panels nested within the 4' x 4' module.

### 3.5 Order of Installation

#### 3.5.1 Molding

Secure wall molding to the perimeter in the same manner as with a traditional grid installation.

#### 3.5.2 Hanging Points

Follow manufacturer's instructions to secure hanging points based on main beam location, following suspension rules in Section 3.2. Trim wire wrap tails to prevent panel damage during installation.

**NOTE:** When laying out wires, it's recommended to position the hanger wires so that they align with the main beams and 4' Cross Tee intersection (**Fig 12**).

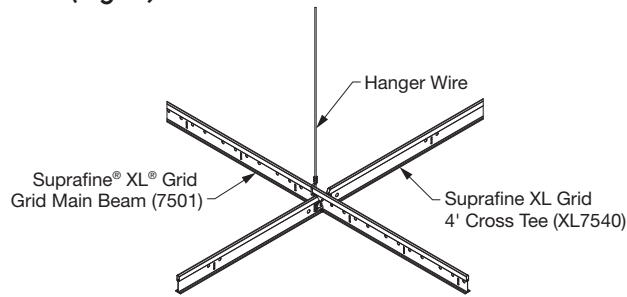

(Fig 12)

### 3.5.3 Main beams

Hang main beams in the same manner as with a traditional grid installation.

### 3.5.4 4' XL Cross Tee

Install 4' Cross Tees intersecting the main beam at 90 degrees every 48" O.C., creating a 4' x 4' grid module (**Fig 13**).

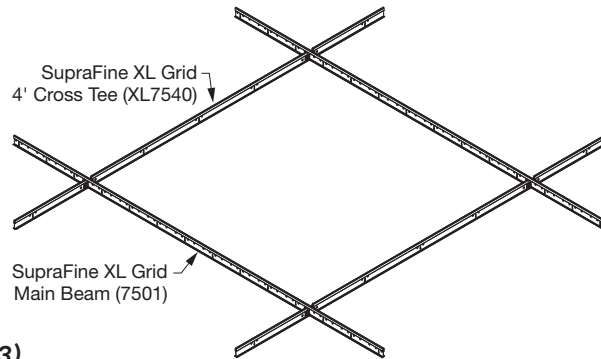

(Fig 13)

### 3.5.5 Hanging Points Required for XM Cross Tee

Place hanger wires at the mid point of the 4' x 4' grid module to support XM Cross Tees (**Fig 14**). It's recommended to wait until the 4' x 4' grid is laid out to accurately locate the midpoint within the 4' x 4' grid opening.

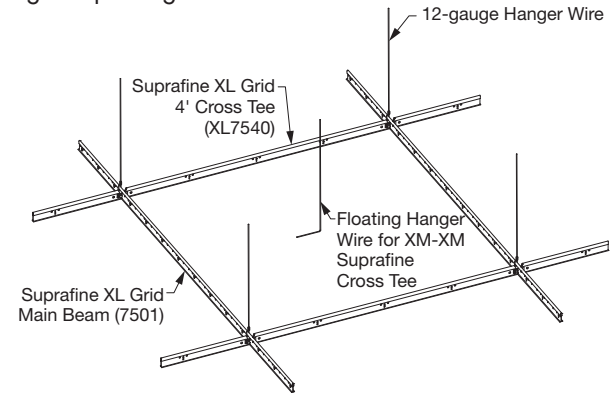

(Fig 14)

**IMPORTANT NOTE:** In situations where grid modifications are necessary (refer to Section 5 and the architectural drawings), leaving only a single corner bracket, reposition the hanger wire originally meant for the XM cross tee so that it supports the remaining corner.

### 3.5.6 Pre-Assemble Components on the Floor

For efficient installation, pre-assemble the following components on the floor (**Figs 15 & 16**):

- (2) – XL/XM Cross Tee
- (1) – XM Cross Tee
- (2) – 90-Degree Corner Brackets

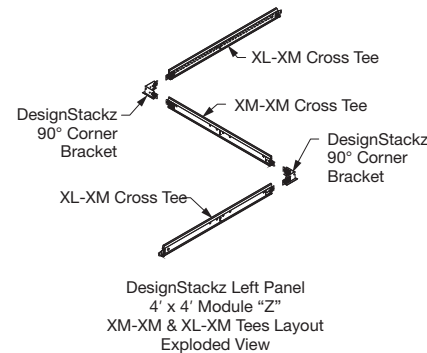

(Fig 15)

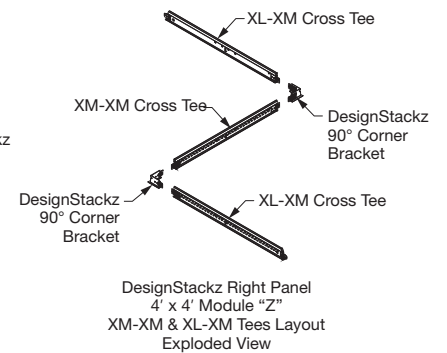

(Fig 16)

### 3.5.7 Transfer to Grid

Once pre-assembled, transfer these components to the 4' x 4' grid module (Fig 17).

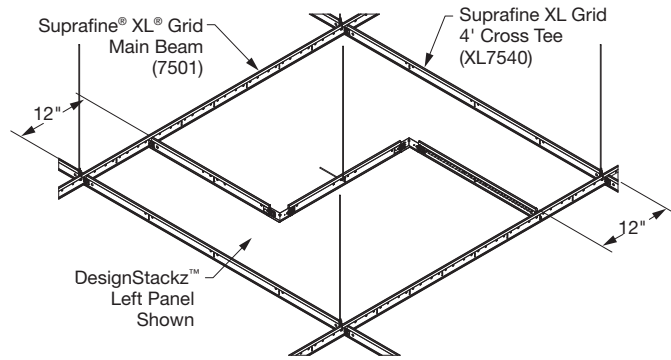

(Fig 17)

### 3.5.8 Secure the XM Cross Tee

Attach hanger wire to the midpoint of the XM Cross Tee to secure it to the structure. To ensure a plumb and level installation within each 4' x 4' module, tighten the required 12-gauge hanger wire connected to the XM tee after installing one of the panels nested within the module (Fig 18).

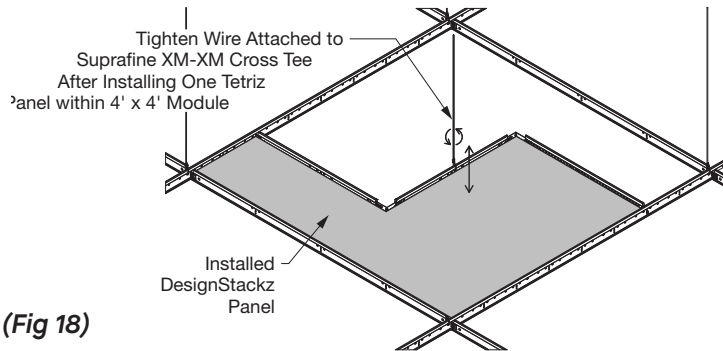

(Fig 18)

### 3.5.9 Add STAC Clip Where Needed

In certain grid layouts, a single Cross Tee might occupy a rout hole. Identify the areas where STAC Clips are necessary and place the STAC clips in those locations. Once the STAC Clips are in place, secure them using pop rivets (Fig 19). **Pro Tip:** Installing the STAC Clips before adding the Cross Tee significantly simplifies the overall installation process.

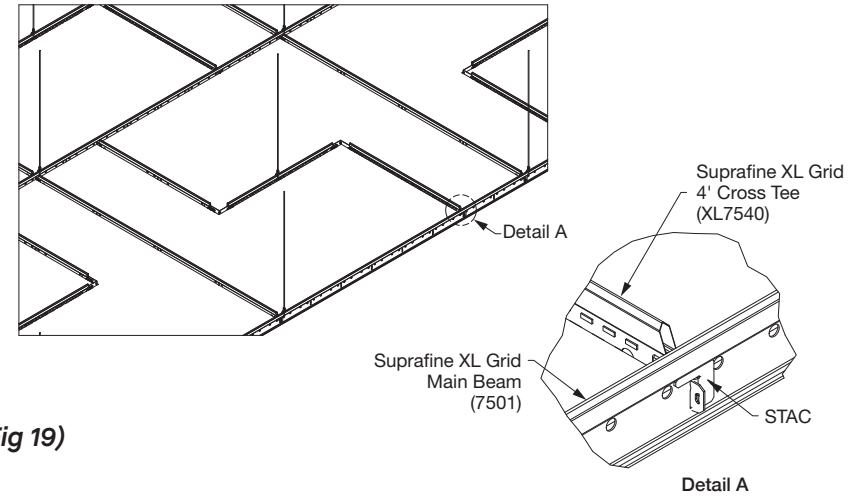

(Fig 19)

### 3.6 Perimeter Attachment to Wall

Main beams and Cross Tees interface with the wall molding as in traditional installations and can be secured to the molding by BERC2 or pop rivets. When making cuts at perimeters, it is essential to consider potential grid modifications. For detailed information on perimeter cuts and solutions, please refer to Section 5.



## 4. FLOATING PERIMETER

Utilizing Axiom® Trim in your full-size panel designs provides additional control of overall dimensions. The suspension layout for floating perimeters or cloud applications should be the same as detailed in Section 3 (**Figs 20 & 21**).

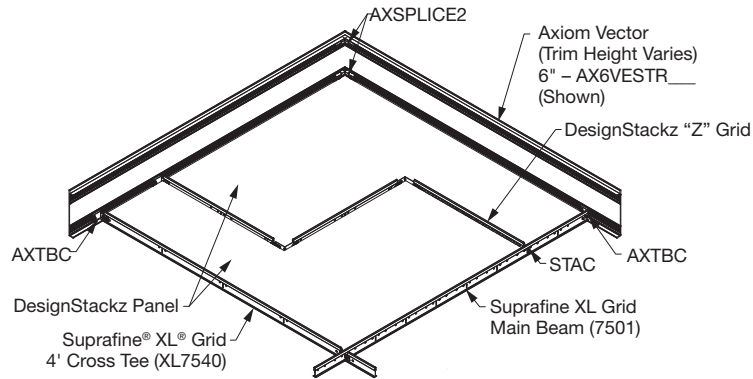

(Fig 20)

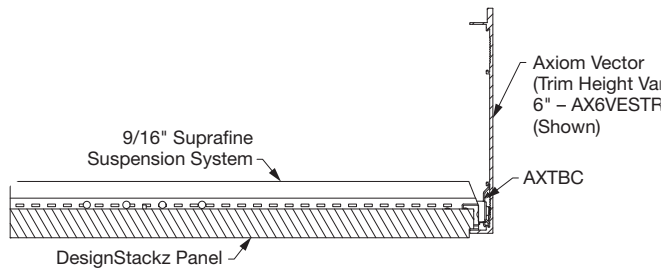

(Fig 21)

Refer to the installation instructions for the specific Axiom Trim product being used. For requirements for Axiom Trim 10" or more in height, refer to Axiom Classic Instructions.

## 5 GUIDELINES FOR CUTTING DESIGNSTACKZ™ PANEL AND GRID

These guidelines assist in handling areas that require cuts in the DesignStackz™ ceiling system. Installers should use these guidelines to assess whether DesignStackz panels and grid layouts can be preserved or to explore alternative options when modifications are necessary.

**Layout Planning:** Consider all areas that may require cutting, such as border panels, columns, or other factors. These cuts should not be related to MEP systems, Refer to Section 7 for MEP integration. To simplify perimeter cuts, installers may also choose to use 2' x 2' or 2' x 4' border panels.

**Impact Assessment of Critical Zone:** Within each 4' x 4' module requiring a cut, there is a critical zone. Evaluate the impact of the cut on the system when it passes through this critical zone (**Fig 22**):

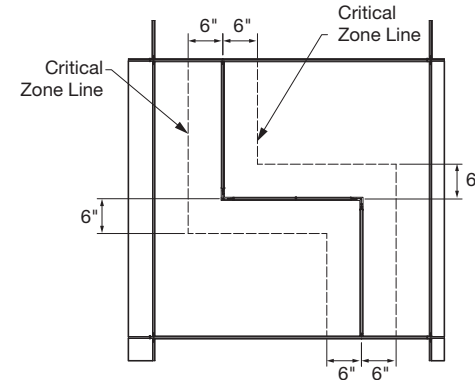

(Fig 22)

Specifically, assess the following

- DesignStackz™ panels with slivers less than 6" (Figs 23 – 25).

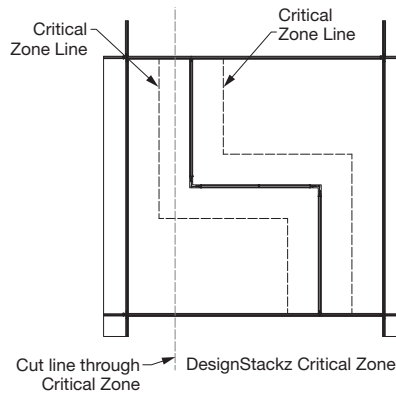

(Fig 23)

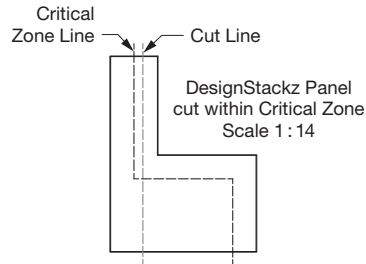

(Fig 24)

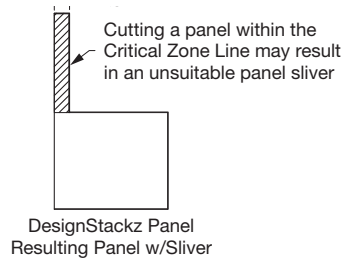

(Fig 25)

- Cuts less than 6" from a 90-degree corner bracket (Figs 26 – 28).

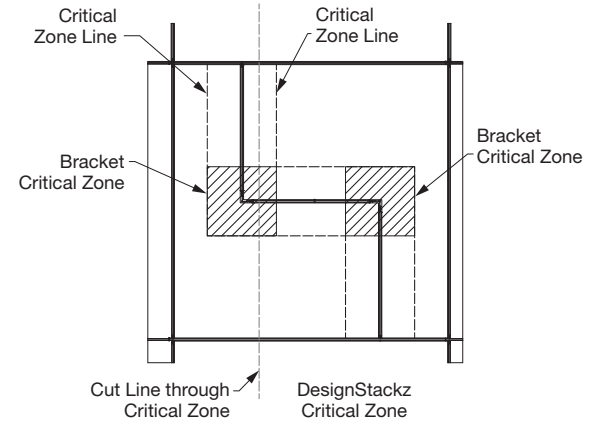

(Fig 26)

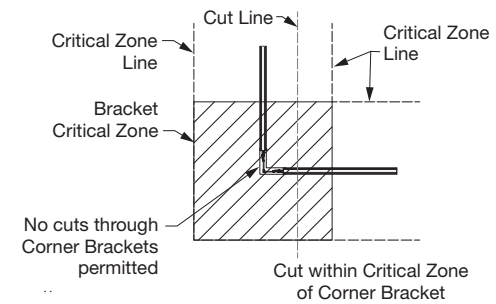

(Fig 27)

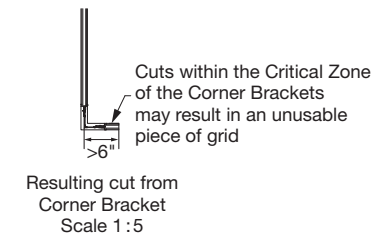

(Fig 28)



**Decision Point:** If cuts compromise the integrity of the panel and/or grid, consider modifying the grid layout. Explore the following alternate grid layouts and panel sizes to balance aesthetics and ease of installation utilizing other panel sizes (e.g., 2' x 2', 2' x 4', 1' x 4', etc.) (**Figs 29 – 34**).

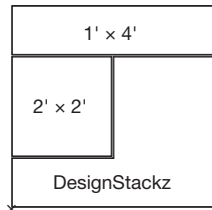

Layout #1  
1- DesignStackz Panel,  
1- 2' x 2' & 1- 1' x 4'

(Fig 29)

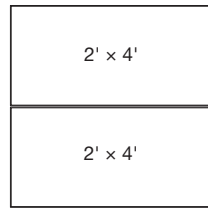

Layout #2  
2- 2' x 4'

(Fig 30)

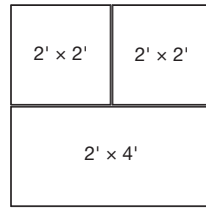

Layout #3  
2- 2' x 2' & 1- 2' x 4'

(Fig 31)

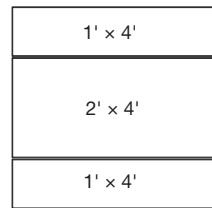

Layout #4  
2- 1' x 4' & 1- 2' x 4'

(Fig 32)

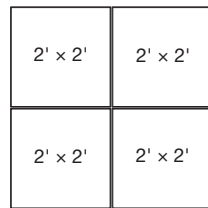

Layout #5  
4- 2' x 2'

(Fig 33)

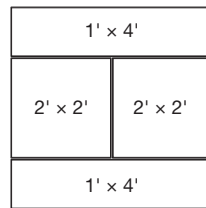

Layout #6  
2- 2' x 2' & 2- 1' x 4'

(Fig 34)

**IMPORTANT NOTE:** In situations where only a single corner bracket remains, you will need to reposition the hanger wire originally meant for the XM Cross Tee so that it supports the remaining corner bracket.

## 6. PANEL INSTALLATION

Mineral fiber and fiberglass DesignStackz™ panels are specifically designed for proper fit into DesignStackz grid openings. Cutting panels or other materials to fit into the grid openings is not recommended and not warranted.

### 6.1 Edge Details/Interface

All tegular panels are for 9/16" Suprafine® grid only. The finish face of the tegular panels extends 1/4" below the face of the grid. (**Fig 35**)

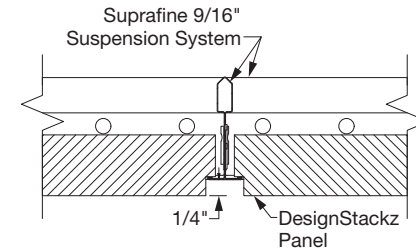

(Fig 35)

**NOTE:** DesignStackz panels are only available for use with 9/16" Suprafine grid. Any made-to-order or special size panels must be ordered to install on 9/16" Suprafine grid.

### 6.2 Directionality

While the panels have no grain directionality, their design forces a specific orientation during installation. Panels can rotate 180 degrees and should be installed in a particular direction that aligns with the grid opening, while following the specified layout.

### 6.3 Installing the DesignStackz™ Panel

When installing DesignStackz™ panels, take care to avoid damage due to their distinctive shape. Follow these steps for a smooth installation:

1. Position the panel with the grid opening, using the inside corner of the panel and the 90-degree corner bracket as your reference points (**Fig 36**).

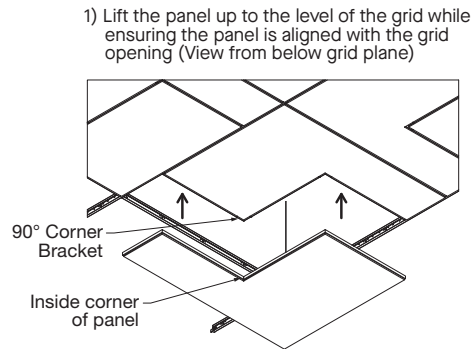

(Fig 36)

2. Lift the panel into the grid, ensuring that the inside corner faces the corner bracket. Lift the panel ends (12" and 24" sides) upward at an angle to clear the grid (**Fig 37**).

2) While keeping the inside corner of the panel and corner bracket aligned, carefully tilt and angle the 12" and 24" sides of the panel up and over the installed grid

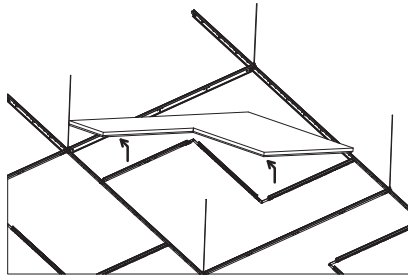

(Fig 37)

3. Gently set the panel in place (as shown in **Figs 38 & 39**).

3) Once the panel has cleared installed grid and corner bracket, align the panel directly over the grid

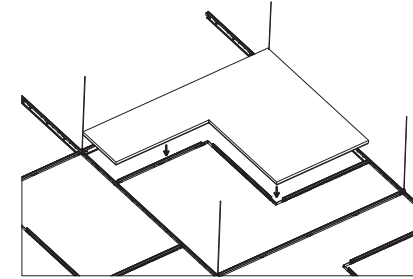

(Fig 38)

4) While maintaining panel and grid alignment, bring the panel down into place

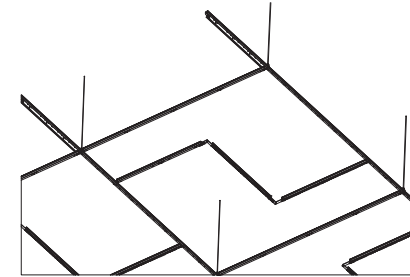

(Fig 39)

### 6.4 Border Panels

For tegular panels there are two options for addressing cut panels at the borders of an installation. **Option A** takes into consideration the 1/4" drop of the panel face below the grid by raising the grid 1/4" so that the face of panels rests on the perimeter trim/molding and cuts are hidden. **Option B** rests the grid on the bottom flange of the molding and requires field-cutting the tegular edge at the border.

When the face of the panel rests on the molding (**Option A**), Spring Border Clips (Item 7870) can be used to keep panel edges aligned, while also preventing the possibility of the panel shifting toward the wall far enough to permit the opposite edge to drop off of the grid flange. When field-cutting the tegular edge (**Option B**), all field-cut edges "exposed to view" should be colored to match the factory finish.

#### 6.4.1 Option A (face of panel on molding) Molding options:

- 7874, 7889 – Shadow Molding
- 7877 – Seismic Shadow Molding for Tegular
- 7800, 7804 – “L” Angle Molding

#### Accessories:

- 7870 – Spring Border Clip
- BERC2 – Beam End Retaining Clip

The suspension system is raised above the bottom flange of the molding by 1/4". This clearance will allow the face of the panel to pass over and rest on the support leg of the shadow molding, while the suspension system rests on the “step” of the shadow molding. An alternate option would be to use a standard “L” angle molding but hold the grid 1/4" above the horizontal flange with the BERC2 clips (**Fig 40**).

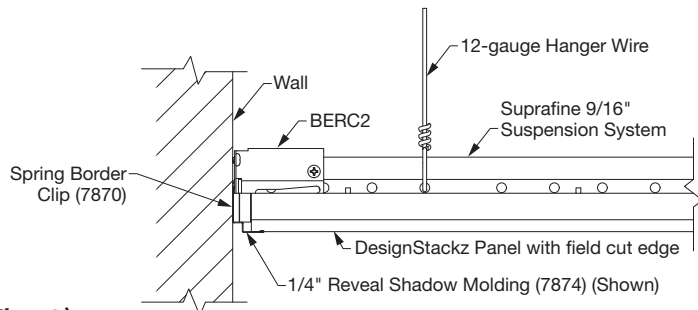

(Fig 40)

This method will create a gap where the suspension system passes over the molding flange, but it eliminates field-cut panel edges that may be exposed to view.

#### 6.4.1.1 Shimming Border Panels

Spring Border Clips can be used to keep panel edges properly indexed against the grid flange. Also, if panels are cut short, Spring Border Clips will prevent the possibility of the panel shifting toward the wall far enough to permit the opposite edge to drop off of the grid flange (**Fig 40**).

#### 6.4.2 Option B (face of grid on molding) Molding:

- 7800, 7804 – “L” Angle Molding

#### Accessories:

- BERC2 – Beam End Retaining Clip

The face of the suspension system rests directly on the horizontal flange of the molding. Tegular edges will have to be field-cut to allow the panel face to drop 1/4" below the grid (**Fig 41**).

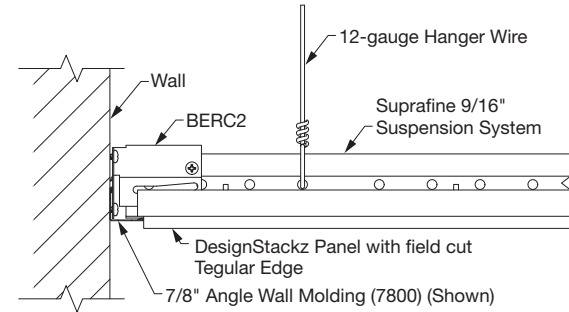

(Fig 41)

#### 6.4.2.1 Treating Exposed Edges

All field-cut edges “exposed to view” can be field-painted to match the factory finish. For touch up paint with custom colors, use recommended Sherwin Williams® PROMAR 200 Zero VOC Interior Latex Flat base paint.

### 6.5 Cut Panels within the Field of the Ceiling

Panels may be cut to allow for fixture penetrations, however, resizing panels for MEP integrations is not allowed. For guidance on MEP integration with the DesignStackz™ ceiling system, please refer to Section 7. Additionally, if you encounter conditions requiring field cutting due to columns or other factors in the field, refer to Section 5 for detailed instructions.

## 7. SPECIAL CONSIDERATIONS

### 7.1 MEP Integration

#### 7.1.1 Techzone® Ceiling System Integrations

TechZone ceiling system is a recommended method for integrating linear fixtures into the DesignStackz system. These technical zones feature mains that run parallel with the standard mains in the system (**Fig 42**).

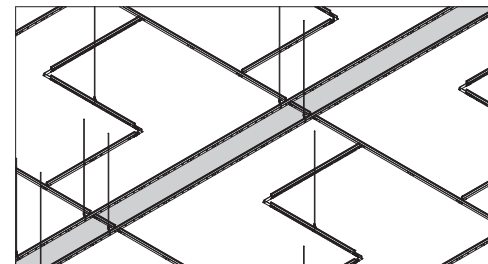

(Fig 42)

## 7.1.2 Lights

### 7.1.2.1 Lighting Partners Integration

Compatible lighting fixtures and drivers should be installed by a qualified electrician. Please refer to the lighting partner manufacturer (JLC-Tech) for detailed instructions. The suspension systems have been designed and tested to support the weight of the light and driver. Be sure to comply with any local code requirements regarding slack or additional support wires.

### 7.1.3 Standard Light & Diffuser Integration

When integrating standard lights or diffusers, such as 2' x 2' fixtures, into DesignStackz™ ceiling system, and its non-traditional grid layouts, it is crucial to anticipate potential adjustments to the grid. This might require using other panel sizes or custom-made panels to accommodate the fixtures (**Fig 43**). In addition, all fixtures must be independently supported.

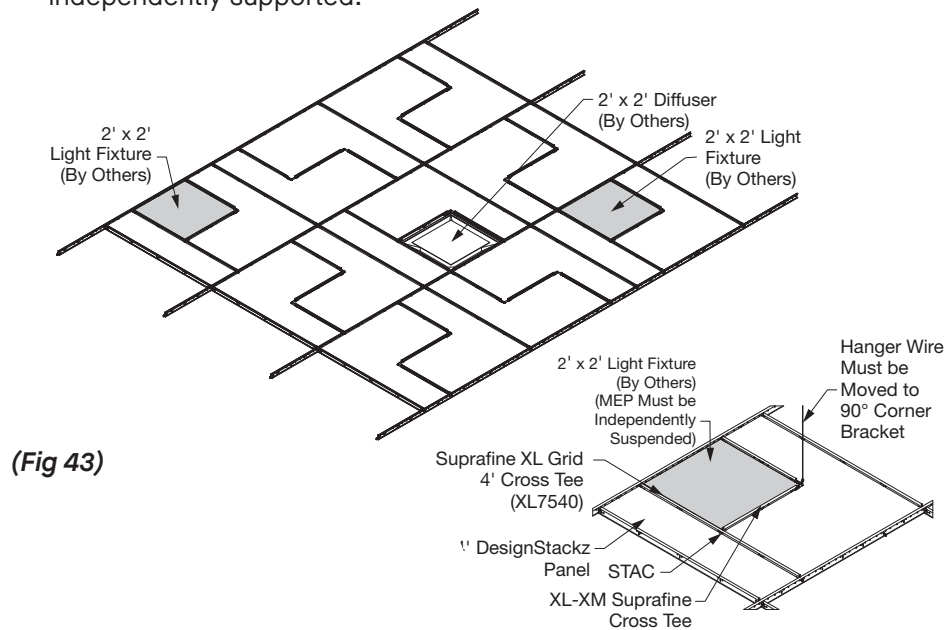

## 8. SEISMIC

### 8.1 General

For more details on Seismic installations please see our brochure: Seismic Design: What You Need to Know.

### 8.2 Suspension System

All seismic installations of DesignStackz panels must be installed per seismic design categories D, E, F. Regardless of the total system weight, Heavy-Duty grid is required per ASTM E580.

### 8.3 Seismic Rx Cat C, D, E and F Ceiling installation should conform to basic minimums established in ASTM C636, with the following exceptions:

- Ceiling installation should conform to basic minimums established in ASTM C636
- Minimum 7/8" wall molding
- Suspension system must be attached on two adjacent walls – opposite walls require BERC2 with 3/4" clearance
- BERC2 maintains main beam and Cross Tee spacing; no other components required
- Heavy-duty systems as identified in ICC-ESR-1308
- Safety wires required on light fixtures
- Perimeter support wires within 8"
- Ceiling areas over 1,000 SF must have horizontal restraint wire or rigid bracing
- Ceiling areas over 2,500 SF must have seismic separation joints or full height partitions
- Ceilings without rigid bracing must have 2" oversized trim rings for sprinklers and other penetrations
- Changes in ceiling plane must have positive bracing

### 8.4 Suspension Layout

Suspension layouts are the same as described in Section 3.

## 8.5 Perimeter Attachment

For wall-to-wall installations, care should be taken with layouts that include 90-degree corner brackets occurring at the wall due to the unevenness of typical wall conditions. Be cautious that any cuts made to accommodate perimeters do not compromise these brackets. Another option is to use 2' x 2' or 2' x 4' border panels, which simplify handling any necessary cuts at the perimeters. Refer to Section 5 for more detailed information.

- Main beams interface with the wall molding as in traditional installations and are secured to the molding by 2" Beam End Retaining Clip (Item BERC2) connection to meet the attached and unattached wall requirements (**Figs 44 & 45**).

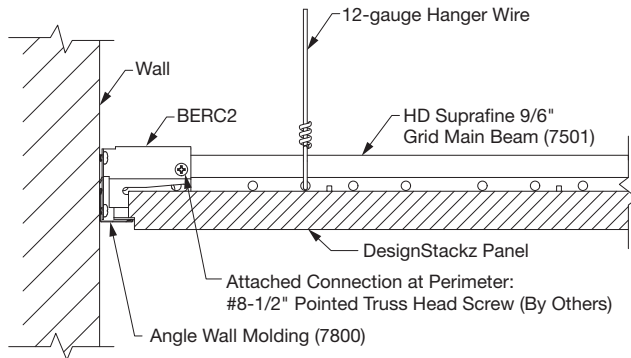

(Fig 44)

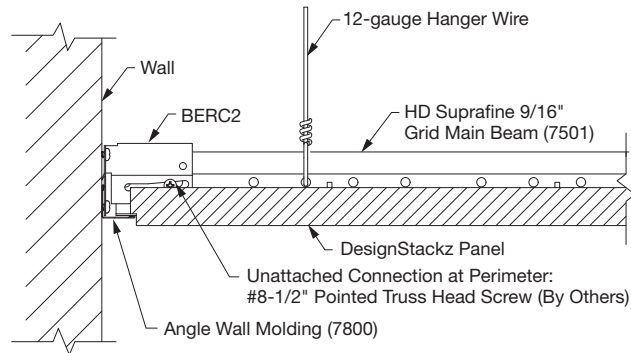

(Fig 45)

- Three-way Adapter Clips (GC3W) are required at all main beam and 4' Cross Tee intersections along the perimeter (**Fig 46**).

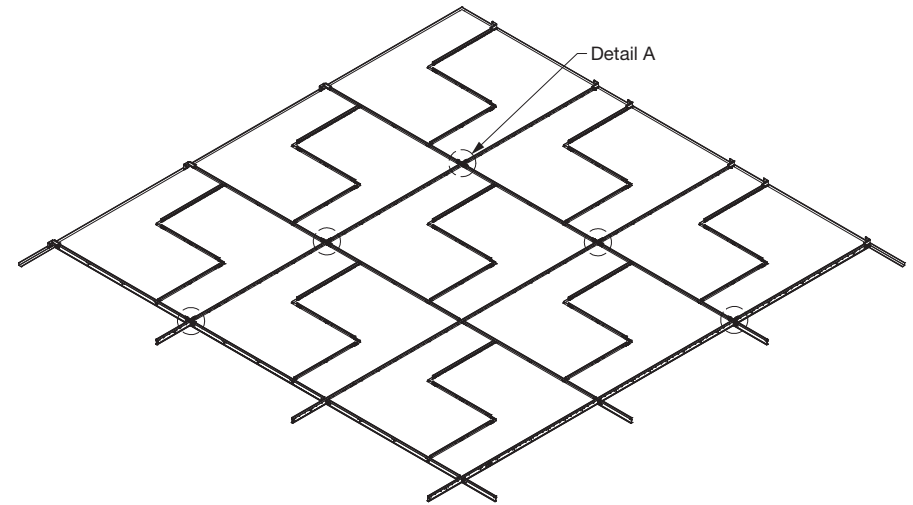

(Fig 46)

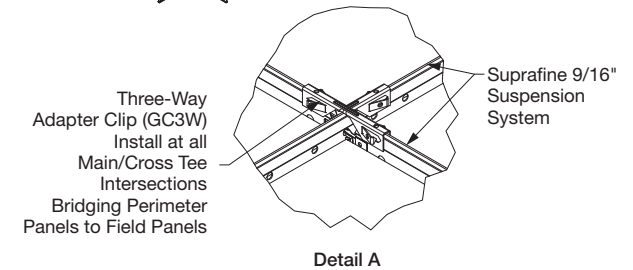

| <b>DESIGNSTACKZ™ CEILING SYSTEM PROPERTY TABLE</b> |                                 |  |                                 |
|--|---------------------------------|--|---------------------------------|
| <b>Item No.</b>                                    | <b>Description</b>              | <b>Ordered Separately/<br/>Included with</b> | <b>Required for<br/>Install</b> |
| <b>Panels</b>                                      |                                 |  |                                 |
| 8790   | DesignStackz Left Panel         | Ordered Separately                           | Based on Design                 |
| 8791   | DesignStackz Right Panel        | Ordered Separately                           | Based on Design                 |
| 8792   | 24" × 24" DesignStackz Panel    | Ordered Separately                           | Based on Design                 |
| 8793   | 24" × 48" DesignStackz Panel    | Ordered Separately                           | Based on Design                 |
| 8794   | 12" × 48" DesignStackz Panel    | Ordered Separately                           | Based on Design                 |
| 8795   | 6" × 48" DesignStackz Panel     | Ordered Separately                           | Based on Design                 |
| <b>Suspension System</b>                           |                                 |  |                                 |
| 7501   | Suprafine® XL® 12' HD Main Beam | Ordered Separately                           | Yes                             |
| XL7540   | Suprafine XL 2' Cross Tee       | Ordered Separately                           | Yes                             |
| XMM7524  | Suprafine XM to XM 2' tee       | Ordered Separately                           | Yes                             |
| XML7524  | Suprafine XM to XL 2' tee       | Ordered Separately                           | Yes                             |
| 75A90D   | Suprafine 90° Angle Bracket     | Ordered Separately                           | Yes                             |
| 7891   | 12-gauge Hanger Wire            | Ordered Separately                           | Yes                             |
| <b>Perimeter Trim</b>                              |                                 |  |                                 |
| 7800   | Angle Wall Molding              | Ordered Separately                           | Based on Design                 |
| 7804   | Angle Wall Molding              | Ordered Separately                           | Based on Design                 |
| 7874   | Shadow Molding                  | Ordered Separately                           | Based on Design                 |
| 7889   | Shadow Molding                  | Ordered Separately                           | Based on Design                 |
| AX_VESTR   | Axiom Vector Straight Trim      | Ordered Separately                           | Based on Design                 |
| <b>Floating Trim</b>                               |                                 |  |                                 |
| AX_VESTR   | Axiom Vector Straight Trim      | Ordered Separately                           | Based on Design                 |
| AX_VECUR   | Axiom Vector Curved Trim        | Ordered Separately                           | Based on Design                 |
| <b>Accessories</b>                                 |                                 |  |                                 |
| GC3W   | 3-way Grip Clip                 | Ordered Separately                           | Yes – Seismic D,E, & F          |
| BERC2  | 2" Beam End Retaining Clip      | Ordered Separately                           | Based on Design                 |
| STAC   | Single Tee Adapter Clip         | Ordered Separately                           | Based on Design                 |
| 7870   | Spring Boarder Clip             | Ordered Separately                           | Based on Design                 |

#### **MORE INFORMATION**

For more information, or for an Armstrong Ceilings representative, call 877 276-7876.

For complete technical information, detail drawings, CAD design assistance, installation information, and many other technical services, call TechLine customer support at 877 276-7876 or FAX 800 572-TECH.

All trademarks used herein are the property of AWI Licensing LLC and/or its affiliates.  
© 2024 AWI Licensing Company Printed in the United States of America

BPLA-293632-523



**Armstrong®**  
World Industries