

DynaMax[®] and DynaMax[®] Plus Structural Suspension System

Assembly and Installation Instructions

Hardware That Needs to be Purchased Separately:

- 3/8"-16 Threaded Rod for Connections to Structure
- #8 Pan Head Screws

DO NOT REMOVE SUSPENSION SYSTEM FROM THE CARTON UNTIL YOU READ THESE INSTRUCTIONS IN THEIR ENTIRETY.

1. SYSTEM OVERVIEW

DynaMax[®] and DynaMax[®] Plus Structural Aluminum Data Center Suspension Systems are designed to offer flexible and reconfigurable support of heavy loads, including data center components like bus bars, hot and cold aisle containment, and other hanging elements via 3/8"-16 threaded rod connections to structure. Both of these systems combine the ceiling system with a structural component, and integrate seamlessly with Armstrong ceiling panels. Please refer to **(Table 1)** on page 14 for a full list of ceiling panels that are specially sized and engineered for the DynaMax and DynaMax Plus suspension systems and must be used with the systems.

The diagram in **(Fig 1A)** provides an overview of the DynaMax suspension system components, clips, and accessories. For this same overview with DynaMax Plus main beams and cross tees, please refer to **(Fig 1B)** on the next page.

NOTE: These panels are specially sized and engineered for DynaMax and DynaMax Plus suspension systems and must be used with the systems. These panels do not fit in other suspension systems.

IMPORTANT: The DynaMax brackets are designed to be used with DynaMax and DynaMax Plus only. They are designed for specific duty loads that are specified in the load charts provided in our DynaMax and DynaMax Plus Technical Guides. When hanging heavy loads greater than those specified in the load charts, consultation by a local engineer is required. Also, please be sure to review the installation and securing recommendations for any load that will be supported by the suspension system. Armstrong is not liable for improper use or improper installation of DynaMax, DynaMax Plus, or its components.

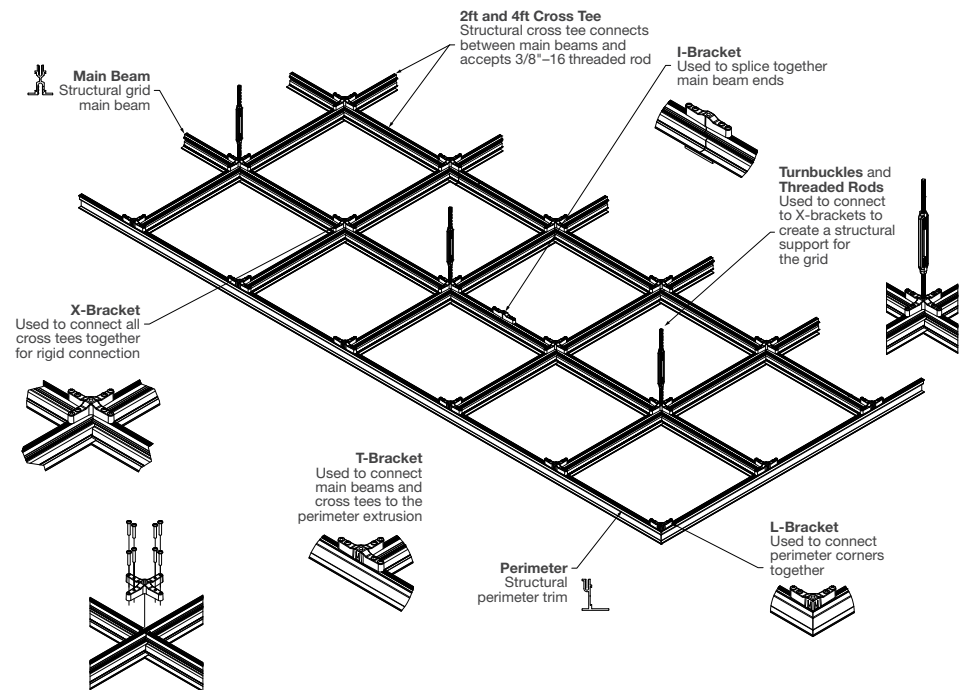

(Fig 1A)

Please refer to Section 10 for specific information on the allowable loads for the suspension system.

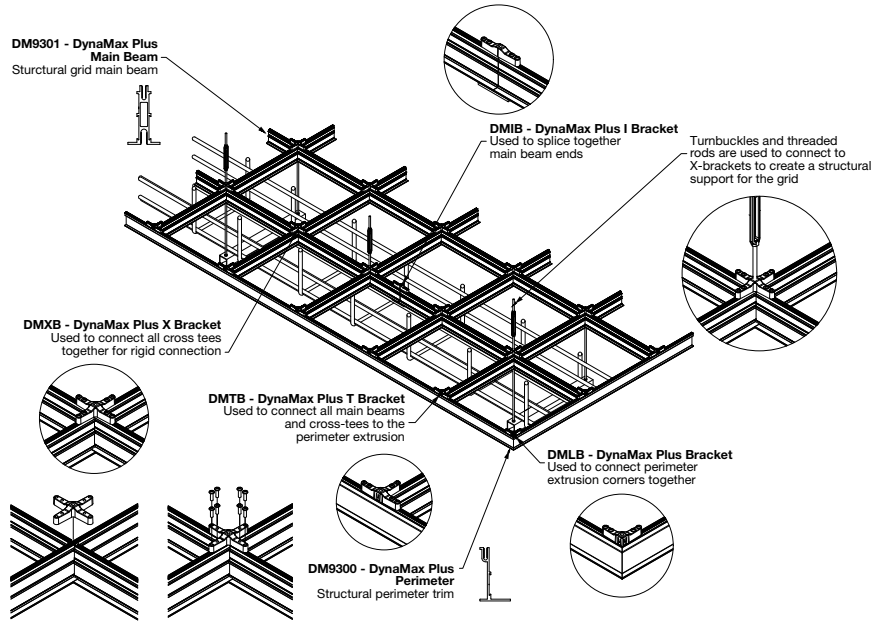

(Fig 1B)

2. INSTALLATION CONSIDERATIONS

The DynaMax® and DynaMax® Plus Structural Aluminum Data Center Suspension Systems are designed to be installed with 3/8"-16 threaded rod from structure.

2.1 Lay out the space, marking the locations of the hanger rods, main beams, and cross tees, and note any mechanicals that will be supported overhead. Be sure to follow the locations and direction of the threaded rod, hangers, main beams, and cross tees a specifying architect/engineer. If plumb threaded rod drops are not possible, then a trapeze or sub framing may be required (Fig 2). This sub or trapeze framing must be engineered to support the designed loads.

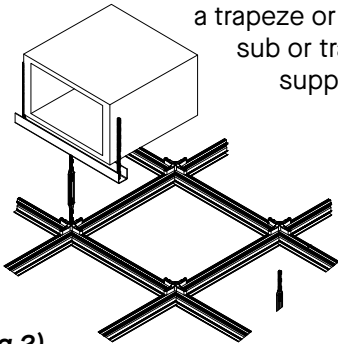

(Fig 2)

2.2 Perimeter Options

Install the DynaMax Perimeter Molding DM4800 (Fig 3A) or DynaMax Plus Perimeter Molding DM9800 (Fig 3B). It is recommended to predrill holes in the perimeter 16" or maximum 24" O.C. to allow screws to pass through and secure the perimeter to studs or structure. **OPTION A (Fig 4A & Fig 4B)**. The wall angle can be attached to studs or structure using screws. A slot is present on the perimeter to assist in drilling. Perimeter molding needs to have threaded rods (4' O.C. max) if loads are applied. If not, screws are acceptable (Fig 5A & Fig 5B).

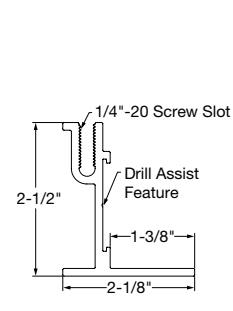

(Fig 3A)

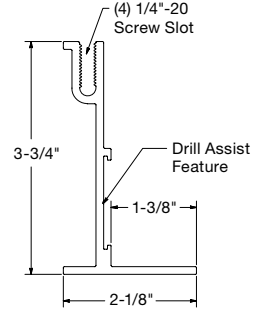

(Fig 3B)

OPTION A

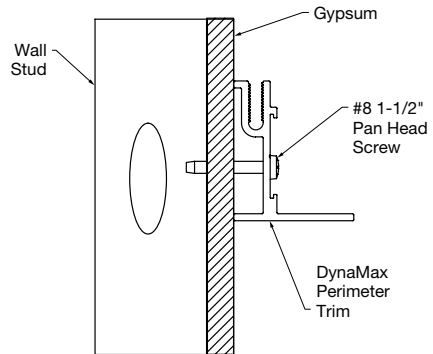

(Fig 4A)

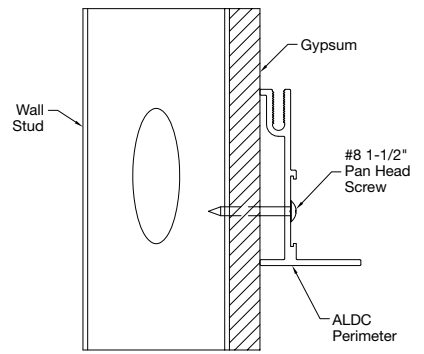

(Fig 4B)

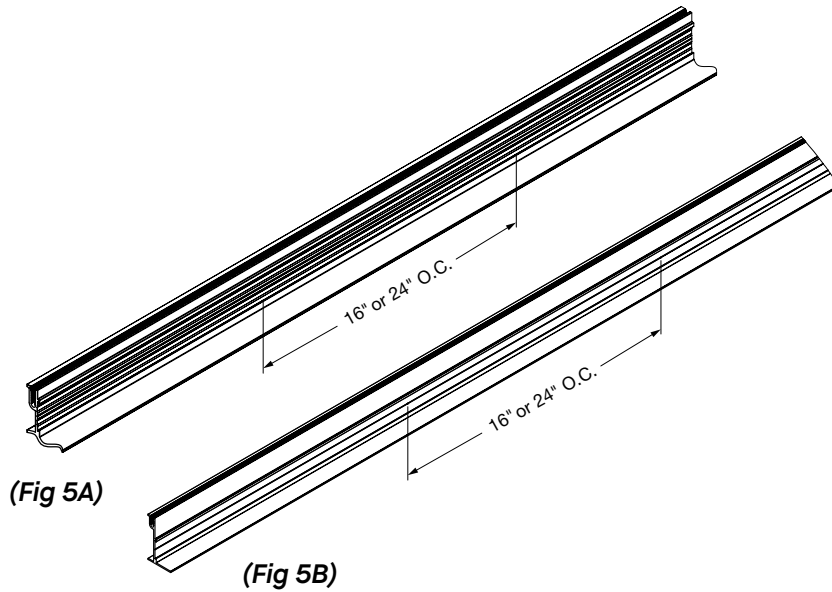

(Fig 5A)

(Fig 5B)

2.2.1 Perimeter Loads

Any loaded grid member at the perimeter requires a support between the perimeter and the load as shown in (Fig 6A). Cross members require support for the grid on either end of the cross member. In situations where grid member is supported within 7" of the perimeter, the perimeter does not require rod drop supports.

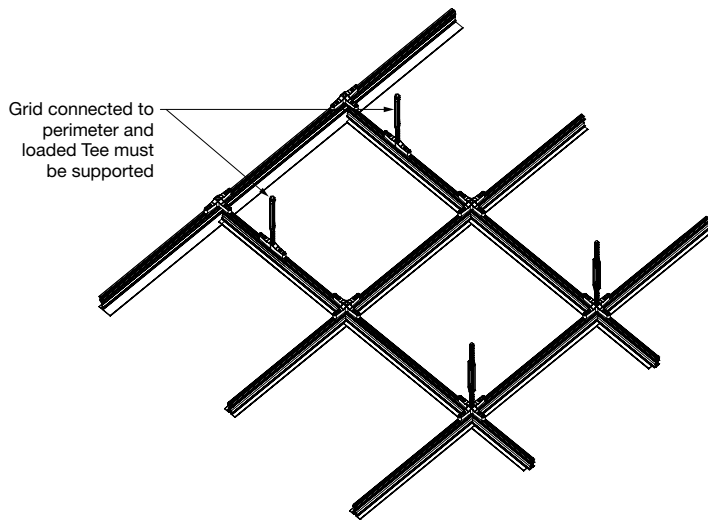

(Fig 6A)

All cross tees and main beams are to be connected to the structural wall angle with a T-Bracket (DMTB) for DynaMax®, using the provided 1/4"-20 screws (Fig 6B). Screws should be fully seated but not over-torqued, in order to avoid damage to the threaded channel. Perimeter moldings should be butt cut and joined together using a I-Bracket (DMIB) for DynaMax in the middle of the wall. **NOTE:** Perimeter cross tees will sit on top of perimeter molding with the override. Gasketing may be required. When gasketing is applied on wall molding additional cuts may be necessary to gasket on either side of grid member to relieve gasket compression at overrides. At corners, perimeter should be mitered and joined together using a L-Bracket (DMLB) for DynaMax (Fig 6C).

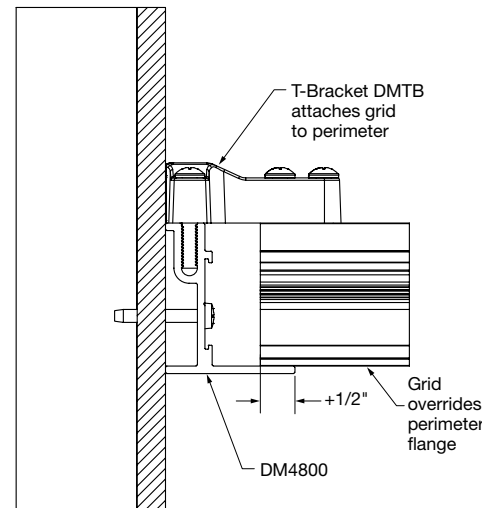

(Fig 6B)

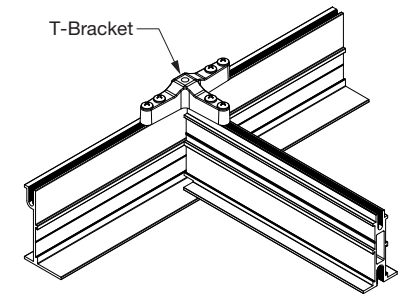

NOTE: Perimeter cross tees will sit on top of perimeter angle with the override. Gasketing may be required. When gasketing is applied on wall molding additional cuts may be necessary to gasket on either side of grid member to relieve gasket compression at overrides.

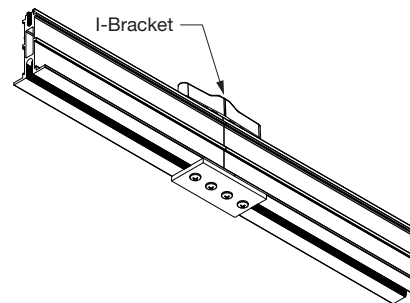

(Fig 6C)

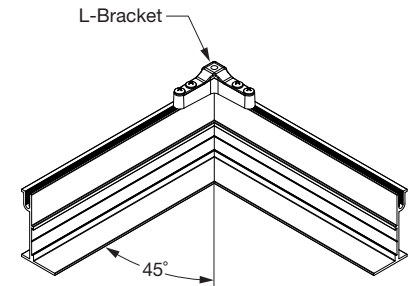

2.2.2 With some layouts, a full modular system can be possible with factory sized tees and mains at the perimeter. In this application, 7/8" wall molding is used to allow for any imperfections in the walls with added tolerance **OPTION B (Fig 7A & 7B).**

OPTION B

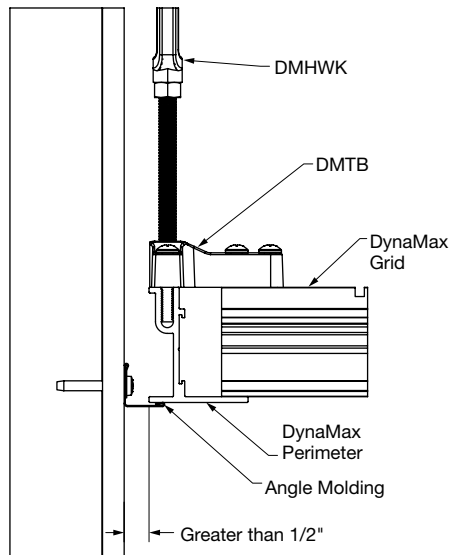

(Fig 7A)

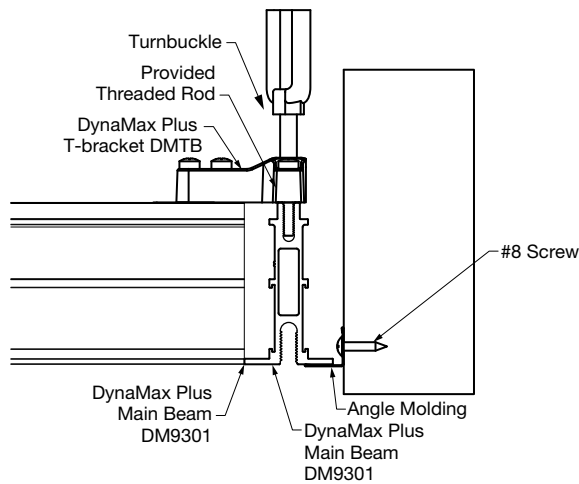

(Fig 7B)

2.2.3 For areas where you have a floating perimeter condition and a threaded rod drop, **OPTION C (Fig 8A & 8B)** is possible. Recommend having greater than 1/2" between the wall and perimeter molding for DynaMax or DynaMax Plus to allow for proper adjusting of the turnbuckle.

OPTION C

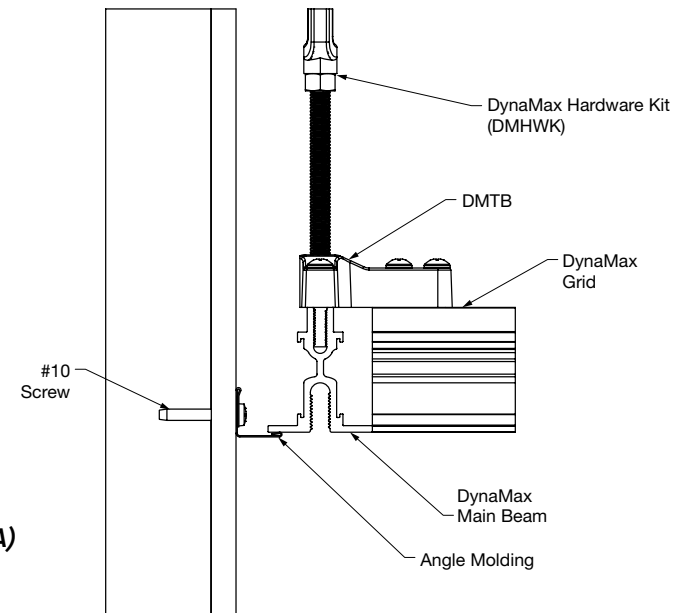

(Fig 8A)

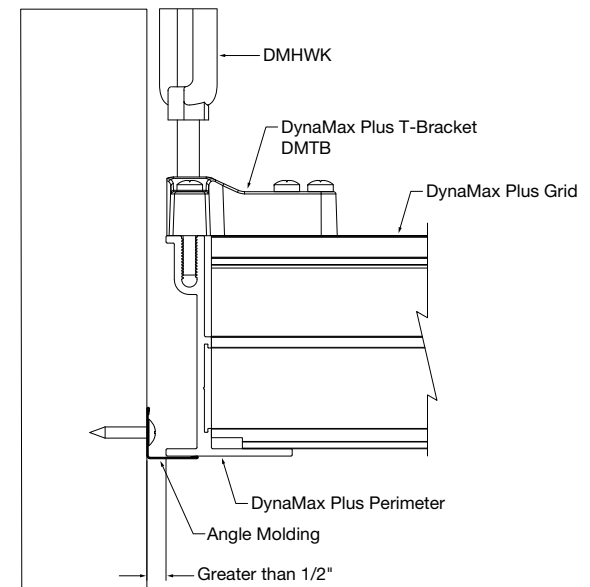

(Fig 8B)

Both DynaMax® and DynaMax® Plus can be designed to connect to perimeter walls and support loads using perimeter molding for DynaMax (DM4800) or DynaMax Plus (DM9800), or the walls can be designed with seismic separation joints as shown in **OPTIONS B and C**. This is ultimately up to the structural engineer on each project. There is no attachment of the acoustical grid to the structural wall molding, so typical seismic requirements do not apply here.

3. Install 3/8"-16 threaded rod hangers into the deck per the recommendations from the deck anchor manufacturer. Threaded hanger rods must be installed plumb with the X-Bracket (DMXB) for DynaMax in all main beam-to-cross tee intersections 4' O.C., unless otherwise specified.

4. Constructing the ceiling suspension system can be pre-fabbed into 4' x 12' modules with a jig table or template. A jig can be used to align and square the main beams and the cross tees of the modules. The X-Bracket (DMXB) and I-Bracket (DMIB) have nubs at the bottom to help self-square.

4.1 For each module, DynaMax main beams are spaced 4' O.C. (**Fig 9**)
NOTE: DynaMax Plus main beams can be spaced at 4', 5', 6' or 8' due to the system's enhanced load-carrying capability and 4', 6', and 8' DynaMax Plus cross tees.

NOTE: The main beams are symmetric. The 4' cross tees are placed 2' O.C. (**Fig 10**) and are aligned to the notches located in the top of the main beams. The main beams are notched every 2' O.C. starting at 1' from the end to aid in a faster installation, preventing jobsite layout measuring and marking.

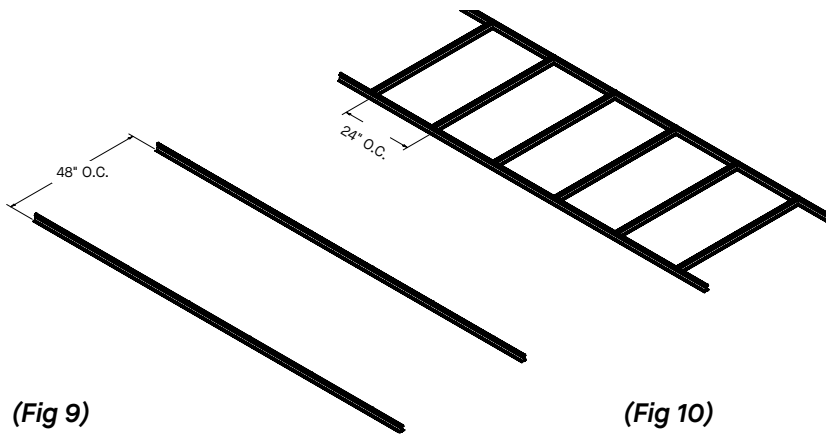

4.2 Insert X-Bracket (DMXB) for DynaMax at every intersection between main beam and cross tee. The DMXB is secured to the main beam and cross tee using the provided 1/4"-20 screws (**Fig 11**). Screws should be fully seated but not over-torqued, in order to avoid damage to the threaded channel.

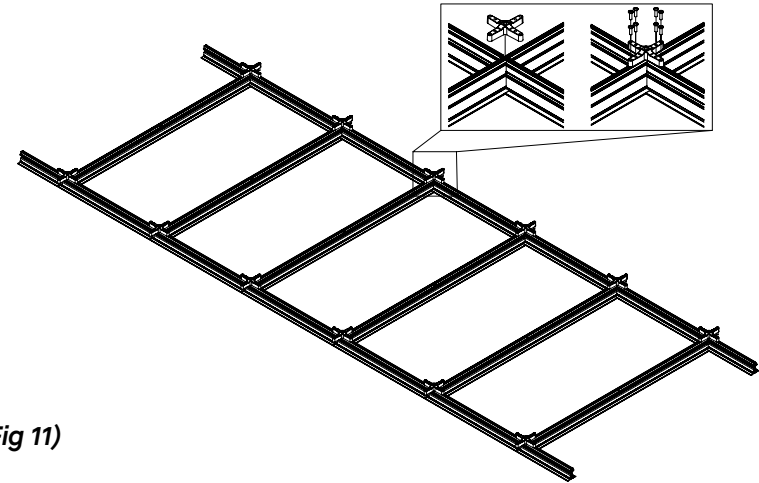

(Fig 11)

4.3 Depending on layout, it may be required to install a 2' cross tee in between each 4' cross tee. Insert the 2' cross tee in between the 4' cross tee on its side. Rotate the 2' cross tee until it is aligned with the notches on the top of the 4' cross tee. Twist the 2' cross tee upright (**Fig 12**).

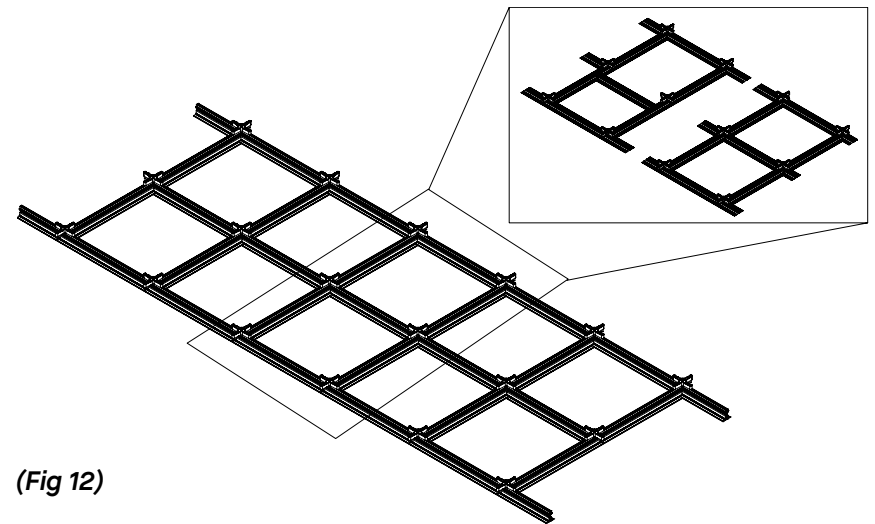

(Fig 12)

4.3.1 Align the 2' cross tees with the notches on the top of the 4' cross tee notches. Secure the 2' cross tee to the 4' cross tee at every intersection using an X-Bracket (DMXB) for DynaMax and the provided 1/4"-20 screws (**Fig 13**). Screws should be fully seated but not over-torqued, in order to avoid damage to the threaded channel.

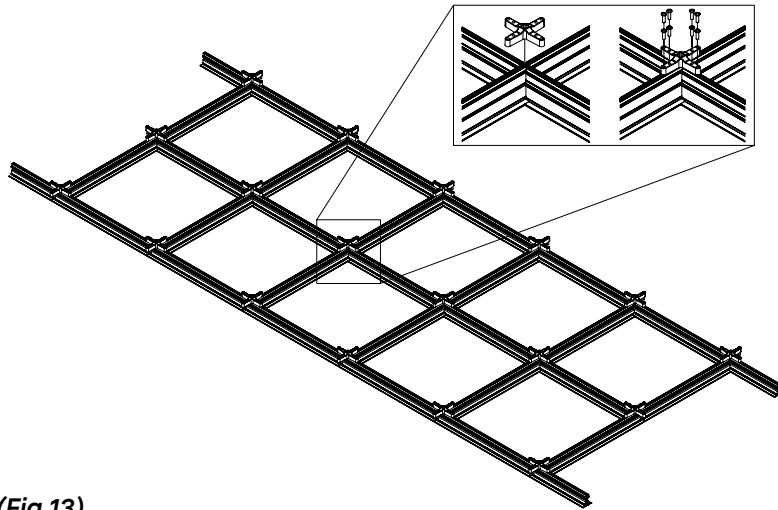

(Fig 13)

4.3.2 Cut threaded rod hanging from the deck 11" up from the finished ceiling height.

4.4 Threaded rods, nuts, and turnbuckles are installed into the X-Bracket (DMXB) for DynaMax every 4' O.C. The threaded rods must be fully engaged with the DMXB and it is recommended that 3 threads are exposed in the turnbuckle (**Fig 14**).

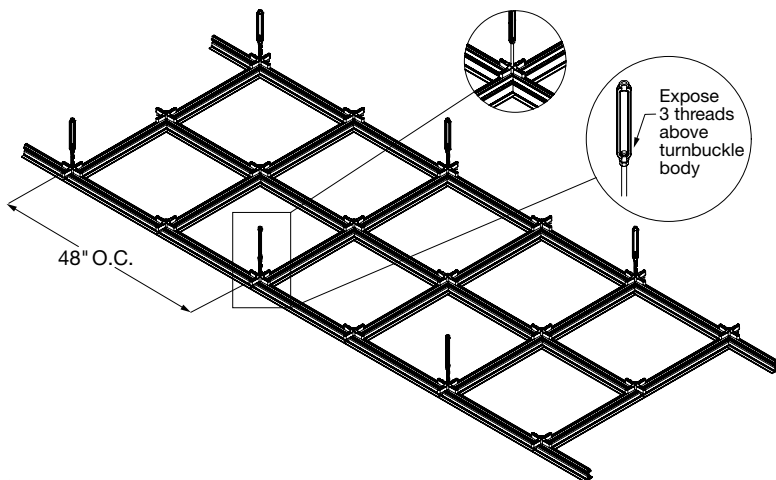

(Fig 14)

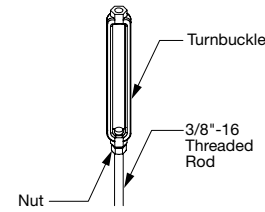

NOTE: Threaded rods are directional with 1" of RH threads that will be inserted into the DynaMax X-Bracket and 3" of LH threads that will be inserted into the turnbuckle. An LH jam nut is provided and should be installed onto the threaded rod before attaching to turnbuckle.

5. Raise each module to the threaded rod drops and attach using the turnbuckles (**Fig 15**). Ensure 3 threads are exposed inside the turnbuckle from the ceiling rod drop. Failure to do so can compromise the integrity of the system. The ceiling height can be adjusted by twisting the turnbuckles (**Fig 16**). After ceiling height is set and leveled, lock the turnbuckle in place using the nut attached to the threaded rod.

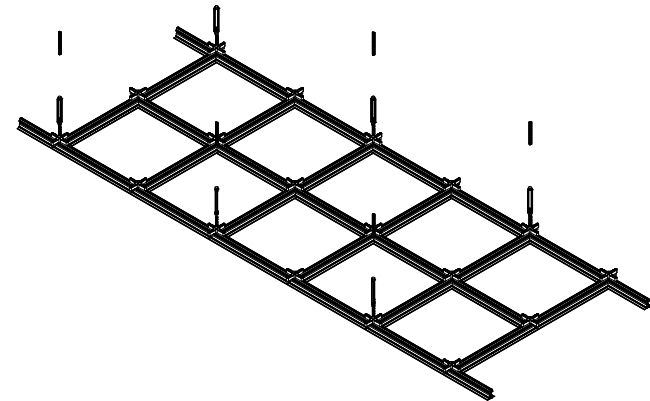

(Fig 15)

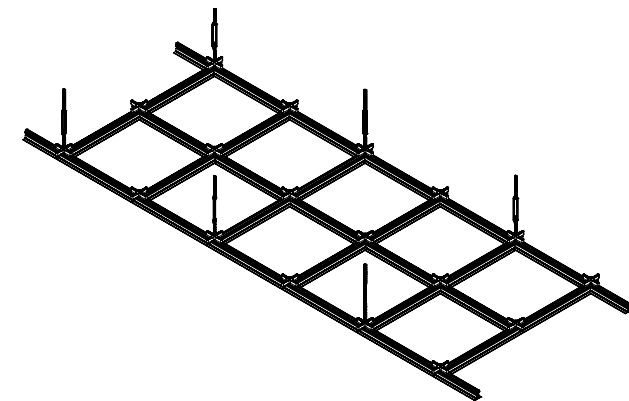

(Fig 16)

NOTE: The 12' x 4' modules are directional. One end of the module will have the turnbuckles and the other ends will not. Ensure the modules are the correct direction before suspending.

6. Suspend the other modules in the same row, adjusting the height and level of each module (Fig 17). At locations where the main beam ends butt against each other, install the I-Bracket (DMIB) for DynaMax onto the top of the main beam using the provided 1/4"-20 screws and the Bottom Splice Plate (DMBSP) for DynaMax onto the bottom of the main beam using the provided 3/8"-16 screws. Screws should be fully seated but not over-torqued, in order to avoid damage to the threaded channel.

NOTE: It is acceptable to align splices throughout the installation and they are not required to be staggered. However, all splices must be supported by a threaded rod support within 12-inches of the splice.

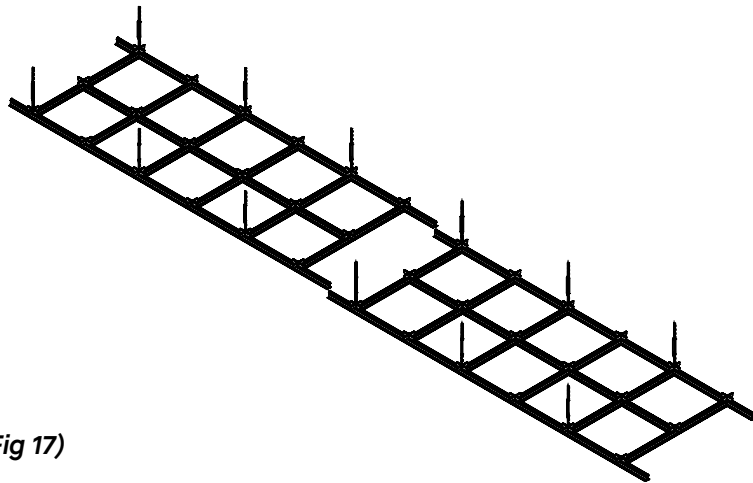

(Fig 17)

Ensure the I-Bracket (DMIB) for DynaMax and the Bottom Splice Plate (DMBSP) for DynaMax is roughly centered, and 2 screws are installed into each main beam. Ensure a threaded rod is within 12" of the splice connection (Fig 18A & 18B).

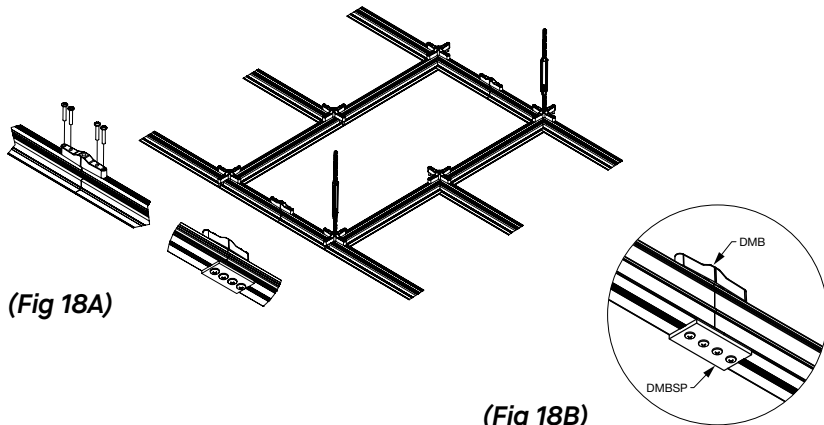

(Fig 18A)

(Fig 18B)

7. Depending on layout, it may be required to install a 2' cross tee in and slide underneath the X-Bracket (DMXB) for DynaMax (Fig 19A). Secure the 2' cross tee to the 4' cross tee at every intersection using DMXB and the provided 1/4"-20 screws (Fig 19B). Screws should be fully seated but not over-torqued, in order to avoid damage to the threaded channel. Ensure a threaded rod is within 12 inches of the I-Bracket (DMIB) for DynaMax for conditions where plumb threaded rod drops are not possible.

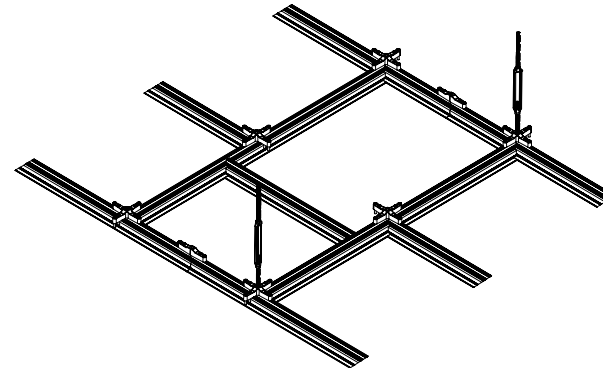

(Fig 19A)

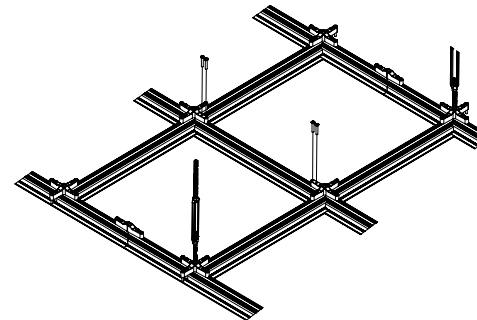

(Fig 19B)

8. Each run of modules are installed 4' apart from each other with 4' cross tee connecting each run. Insert the 4' cross tee in between the modules and slide underneath the X-Bracket (DMXB) for DynaMax (Figs 20A & 20B). Secure the 4' cross tee to the main beam at every intersection using an DMXB and the provided 1/4"-20 screws (Fig 21). Screws should be fully seated but not over-torqued, in order to avoid damage to the threaded channel.

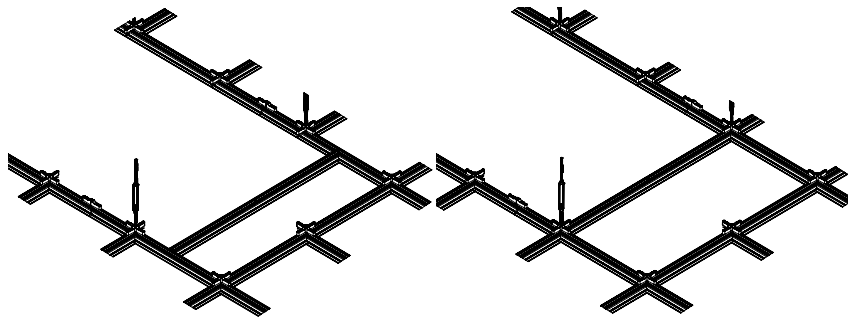

(Fig 20A)

(Fig 20B)

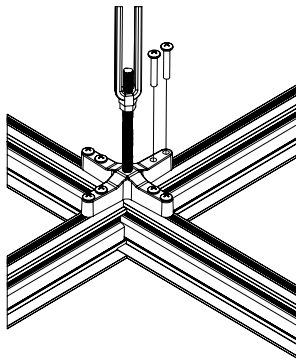

(Fig 21)

9. Depending on the layout of each run of modules, it may be required to install a 2' cross tee in between each module. Insert the 2' cross tee in between the 4' cross tee and slide underneath the DMXB (Fig 22). Secure the 2' cross tee to the 4' cross tee at every intersection using a DMXB and the provided 1/4"-20 screws (Fig 23). Screws should be fully seated but not over-torqued, in order to avoid damage to the threaded channel.

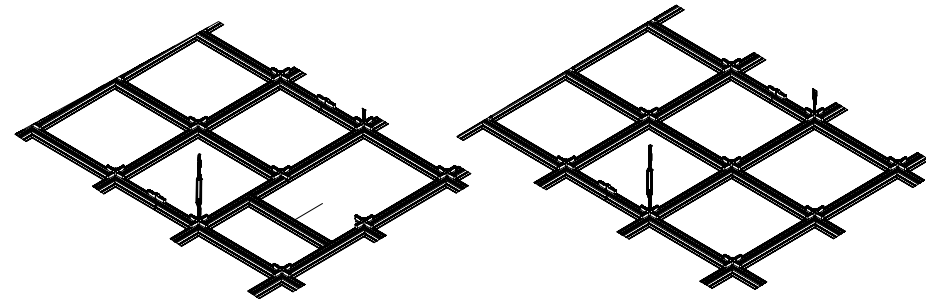

(Fig 22)

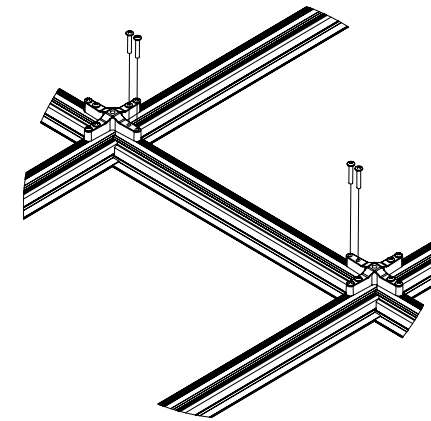

(Fig 23)

10. LOAD CHARTS

DynaMax® Structural Aluminum Grid supports up to a 1,200 LB. point load rating using 3/8"-16 threaded rod at 4' x 4' connection points, assuming loads applied under threaded rod support brackets. For all structural load data please refer to the DynaMax Technical Guide found at: www.armstrongceilings.com/DYNAMAX

DynaMax® Plus supports point loads of over 1,800 LB. point load rating using 1/2"-13 threaded rod at 4' x 4' connection points, assuming loads applied under threaded rod support brackets. For all structural load data please refer to the DynaMax Plus Technical Guide, found at: www.armstrongceilings.com/DYNAMAXPLUS

11. SEISMIC CONSIDERATIONS

These are options/suggestions if lateral bracing is needed. Cable trays need to be independently designed and braced for seismic zone areas (Figs 24A, 24B, 24C, 24D, 24E, & 24F).

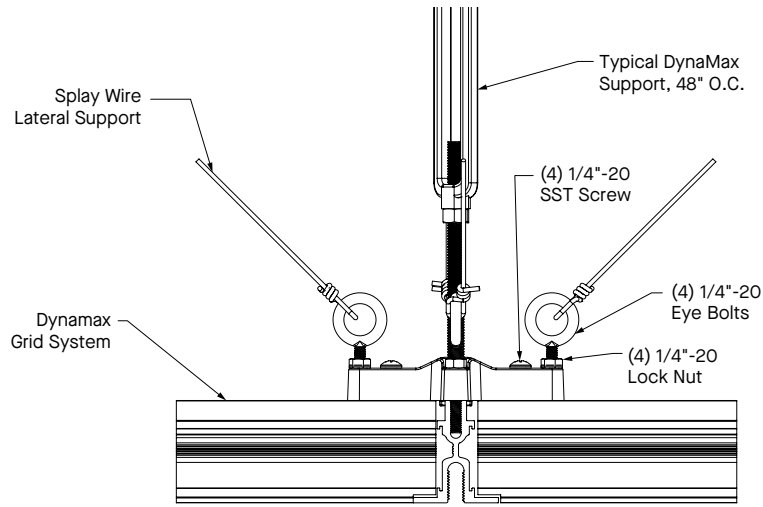

(Fig 24A)

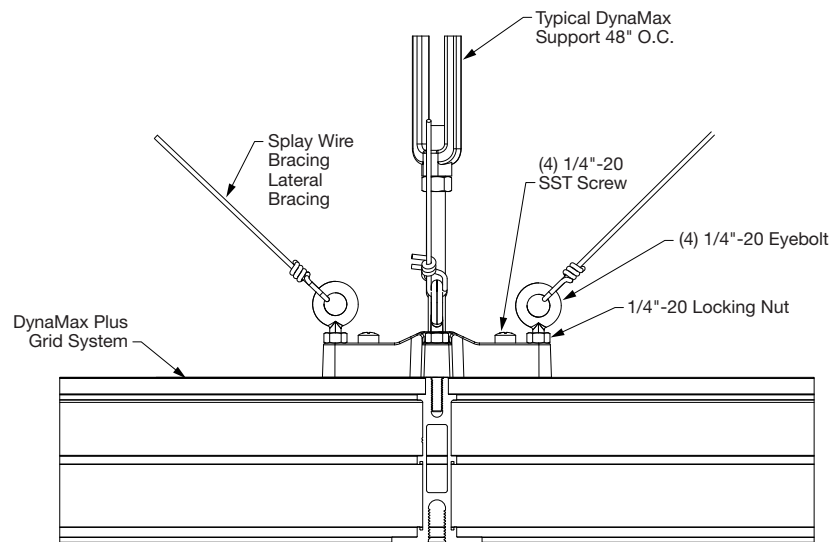

(Fig 24B)

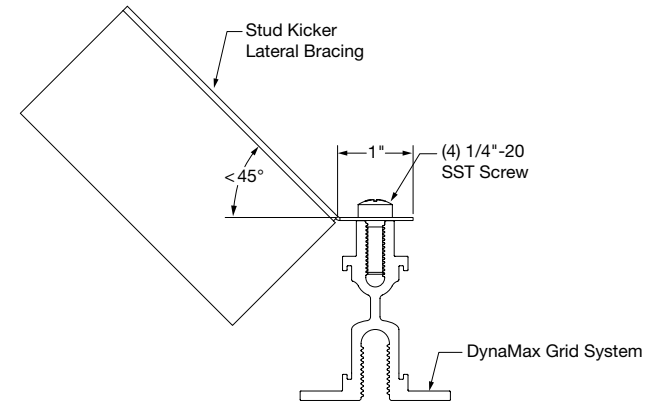

NOTE: Contact local engineer for job specific load and/or seismic requirements.

(Fig 24C)

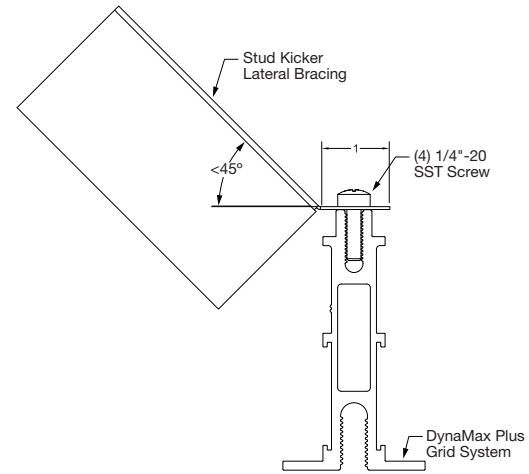

(Fig 24D)

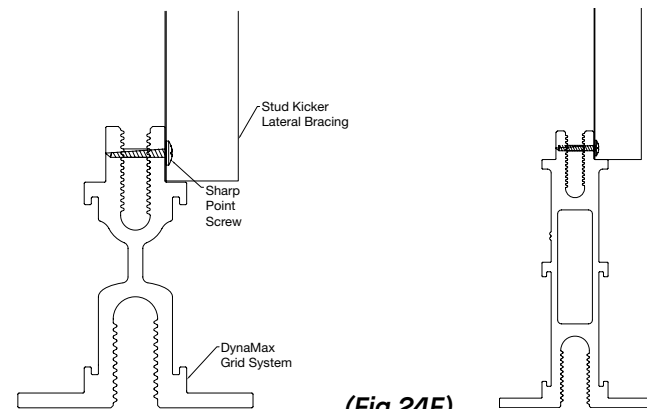

(Fig 24E)

(Fig 24F)

12. HOLD-DOWN CLIPS

Hold-down Clip for DynaMax® (DMHDC) and DynaMax® Plus (DMPHDC) attaches to the suspension system to hold lay-in ceiling panels in place. Depending on the tile thickness being installed, spreading the DMHDC slightly on either side will help the clip engage on the bulb of the grid DynaMax (Fig 25A) or DynaMax Plus (Fig 25B) grid.

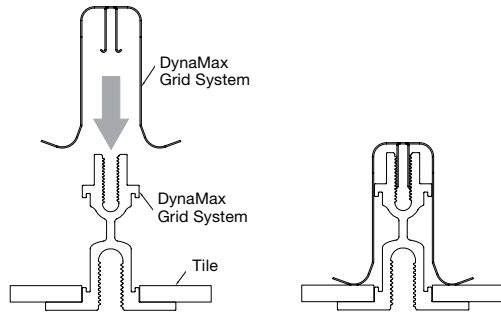

(Fig 25A)

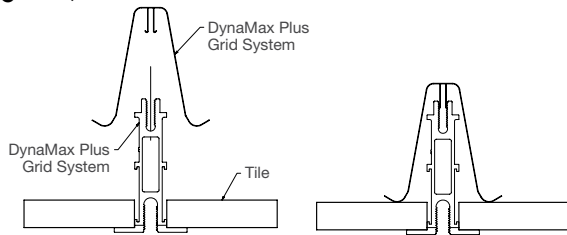

(Fig 25B)

13. T-BAR CONNECTOR CLIPS

The AXTBC (Axiom T-Bar Connector Clip) is used in installations where the DynaMax® or DynaMax Plus® suspension system is used in conjunction with Prelude® XL® suspension system. The AXTBC serves as the transition between the two suspension systems and fits into the attachment feature on the DynaMax (Fig 26A) or DynaMax Plus (Fig 26B) profile.

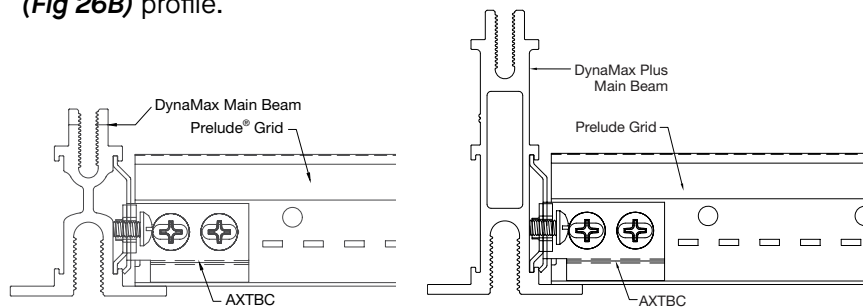

(Fig 26A)

(Fig 26B)

14. METALWORKS™ LAY-IN CEILING PANELS FOR DYNAMAX® AND DYNAMAX® PLUS STRUCTURAL GRID DATA CENTER GRID INSTALLATION DETAILS AND INSTRUCTIONS

14.1 Product Description

MetalWorks™ Lay-in ceiling panels for DynaMax® structural grid is an aluminum ceiling panel available in standard 24" × 48" and 48" × 48" nominal sizes. These panels are specially sized and engineered for DynaMax® and DynaMax® Plus structural suspension system and should be used with this system only. MetalWorks Lay-in panels are finished in a factory-applied polyester paint (post-coated) in standard Whitelume (WHA). Panels also offer perforated options with a black acoustical fleece factory-applied to the back side of the panel for improved acoustics. The surface of these panels is washable, scrubbable, soil-resistant, and non-directional. Optional infill panels are also available for added acoustics (Fig 27 & 28).

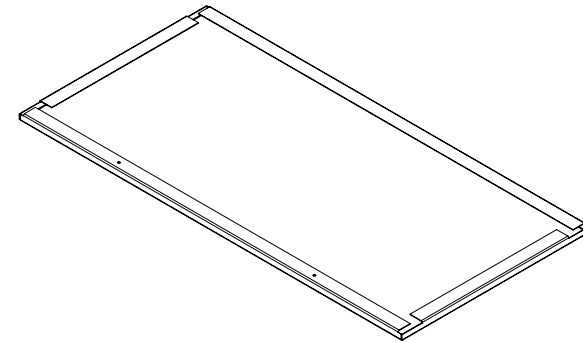

(Fig 27)

23-1/4" × 47-1/4" Panel

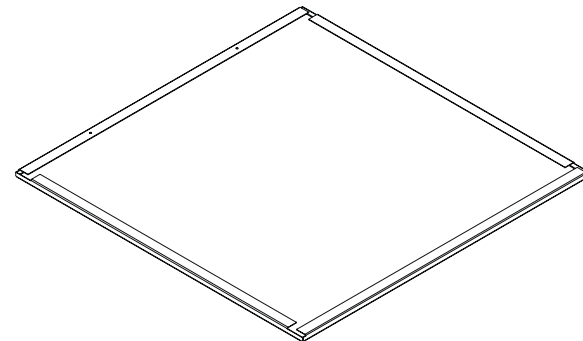

(Fig 28)

47-1/4" × 47-1/4" Panel

14.2 Storage and Handling

The MetalWorks™ Lay-in ceiling panels shall be stored in a dry interior location and shall remain in cartons prior to installation to avoid damage. Proper care should be taken when handling to avoid damage or soiling.

NOTE: MetalWorks Lay-in ceiling panels are packaged with the face of the panel toward the outside of the carton. Exercise care in moving and opening cartons to prevent damage to the panel face. Each panel is foam-wrapped to protect it from dirt and scratching, keep panels foam wrapped until they are ready to be installed. Always wear safety glasses and cut-resistant gloves when handling or cutting metal.

14.3 Plenum

Installation of MetalWorks Lay-in ceiling panel is recommended to have a minimum of 8" above the grid face.

NOTE: Unless supported by the DynaMax® structural suspension system, all MEP must be independently supported to the structure. There must not be weight from any lights, diffusers, speakers, or similar devices supported by the aluminum panels.

14.4 Cleaning

An abrasive or strong chemical detergent should not be used. A mild detergent diluted in warm water, applied with a soft cloth, rinsed, and wiped off with a chamois will maintain the panels in good condition. If not removed by washing, oily or stubborn stains can be wiped with products like Fantastik®, but care is necessary to avoid affecting the gloss level of the paint finish.

14.5 Panel Cutting & Installation Instructions

MetalWorks Lay-in ceiling panels can be cut to size at the perimeters using standard tools and methods for aluminum panels.

CAUTION: Cut edges of metal parts can be extremely sharp! Handle metal carefully to avoid injury. Always wear safety glasses and gloves when working with metal.

- It is recommended to use a metal cutting circular saw with a non-ferrous metal cutting blade (consult blade manufacturer for specific recommendation).
- The quality of the cut can impact the flatness of the cut edge, so deburring or filing might be required.
- When fiberglass (Item 8200T10) infill is used, it also must be cut to size. This is best done with a large pair of shears or scissors. Reseal the poly bag with packing tape prior to installation.

14.5.1 Cut Panel Installation (Fig 29)

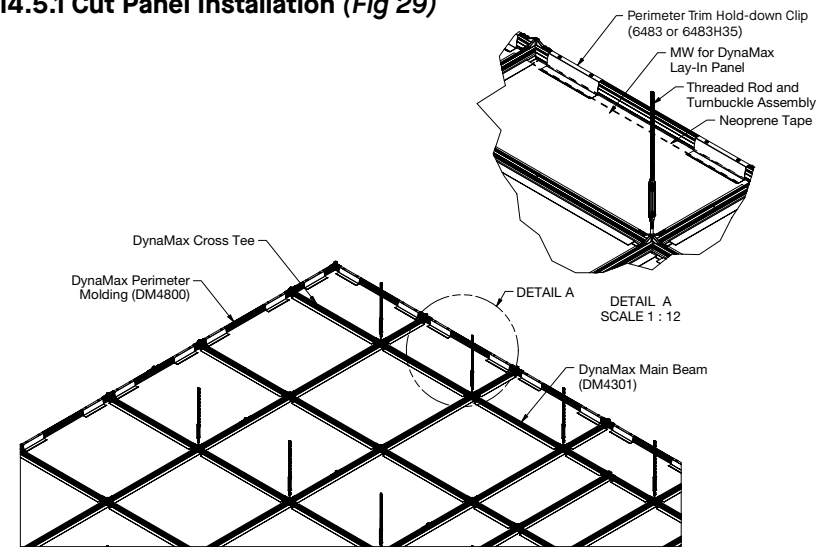

(Fig 29)

It is recommended to install all perimeter panels first starting with corner panels. White 1/8" thick neoprene tape and perimeter trim hold-down clip (Item 6483) are required for perimeter panels and will give the best visual. The following steps should be followed for proper installation:

- Cut the panel to size (Fig 30).

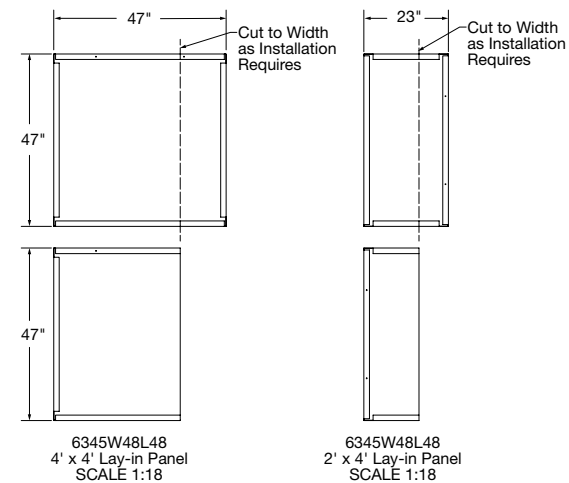

(Fig 30)

- Add 1" wide × 1/8" thick white neoprene tape (item by others), recommend using roll from MSC Direct, to the DynaMax® structural grid perimeter molding (**Fig 31**).

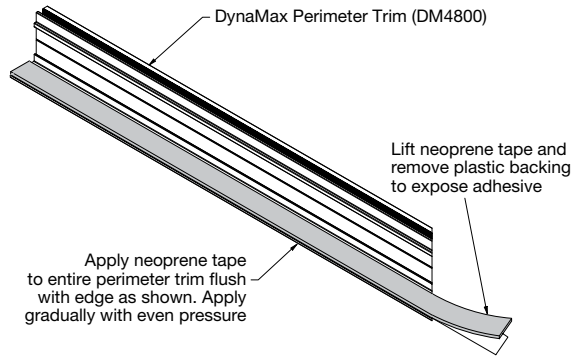

(Fig 31)

- Use 1/4"-20 × 3/4" L screws, fasten perimeter trim hold-down clips (6483 for DynaMax and 6483H35 for DynaMax® Plus) first (**Fig 32**). Screws should be fully seated but not over-torqued, in order to avoid damage to the threaded channel.

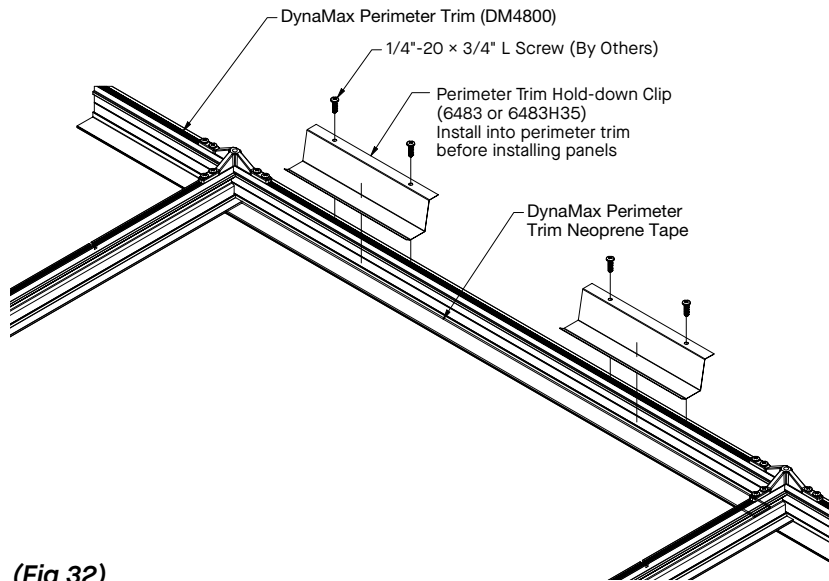

(Fig 32)

- Install cut panels once perimeter trim hold-down clips are in place (**Fig 33**).

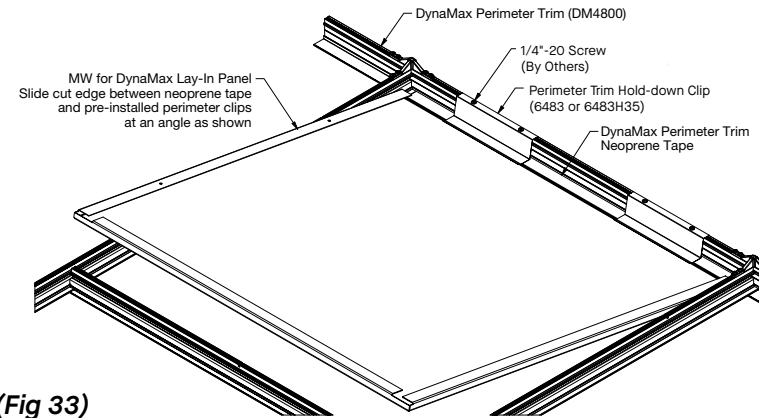

(Fig 33)

- For corner conditions, the following steps need to be followed for proper installation (**Fig 34**).

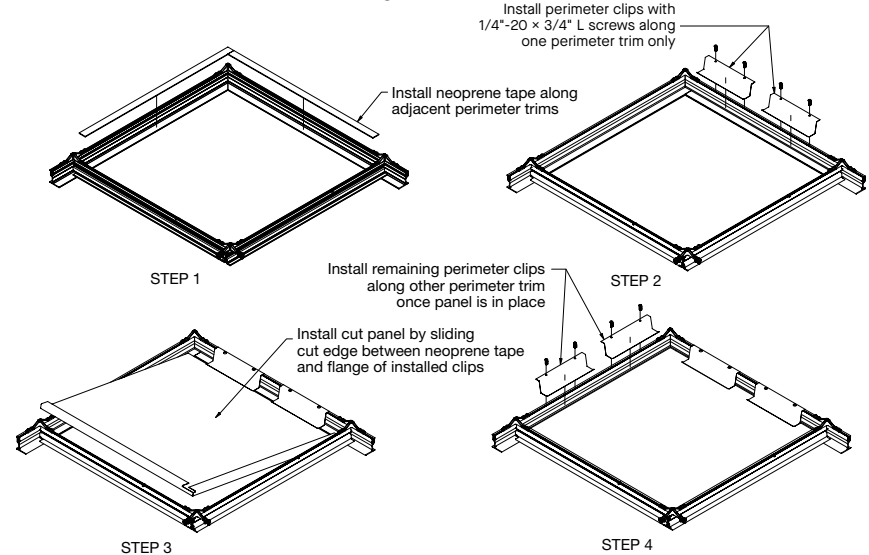

(Fig 34)

1. Add neoprene tape to perimeter trim on both walls.
2. Install perimeter trim hold-down clip (6483 for DynaMax and 6483H35 for DynaMax Plus) using 1/4"-20 × 3/4" L screws along one perimeter trim only. Screws should be fully seated but not over-torqued, in order to avoid damage to the threaded channel.
3. Install cut panel by sliding it between neoprene tape and perimeter trim hold-down clip.
4. Install remaining perimeter trim hold-down clips along the other perimeter trim once the panel is in place.

14.6 Infill Panel Installation (Fig 35)

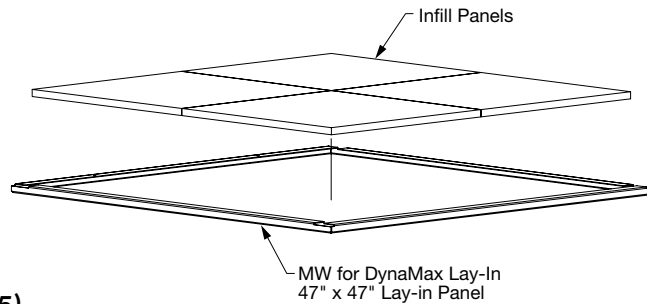

(Fig 35)

Fiberglass panels (8200T10)

Full-size panels: 8200T10 – No cutting required. Place the infill on the back side of the face of the panels.

Cut panels (including borders): 8200T10 – Must be cut to size. This is best done with a large pair of shears or scissors. Reseal the poly bag with packing tape prior to installation.

15. INSTALLING COMPATIBLE LIGHT FIXTURES

Step 1: Assemble Clips

Assemble the clips that are provided by the lighting manufacturer. Please refer to the lighting manufacturer's specific installation instructions for details on light installation, as shown in (Fig 36).

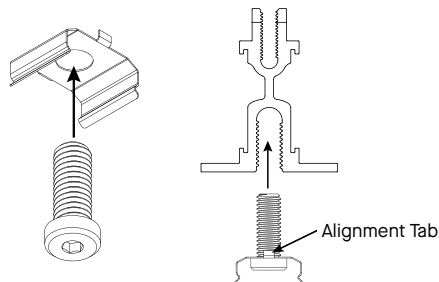

(Fig 36)

NOTE: (Fig 36) shows the standard DynaMax® main beam profile; however, these lighting installations are also compatible with DynaMax® Plus grid.

Step 2: Install Clip to DynaMax

Using a 3/16" hex key, install all clips to installed suspended ceiling system. DO NOT over tighten as this could deform the clip and not allow for installation.

Fixtures will be supplied with two clips for rails under 48", four clips for rails 48" to 72" and six clips for 96" rails. Position two clips 4" (102mm) from each end of the fixture and evenly space the remaining clips.

NOTE: Clip is supplied with alignment tabs to ensure a proper installation. Clip must be installed as shown in (Fig 37).

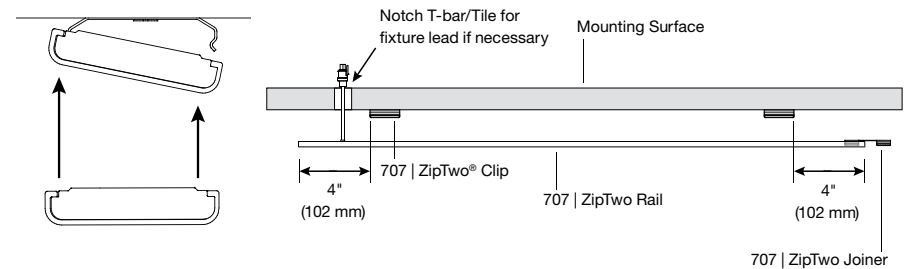

(Fig 37)

Step 3: Install light fixture provided by lighting manufacturer

Please refer to the lighting manufacturer's specific installation instructions for details on light installation.

16. 3/8" CONNECTION PROCEDURES

When installing services to the DynaMax and DynaMax Plus threaded channel, ensure compliance with the detail provided (Fig 38A & Fig 38B) and the accessory/component/equipment manufacturer's installation instructions.

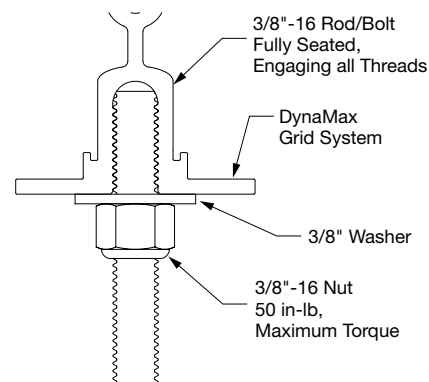



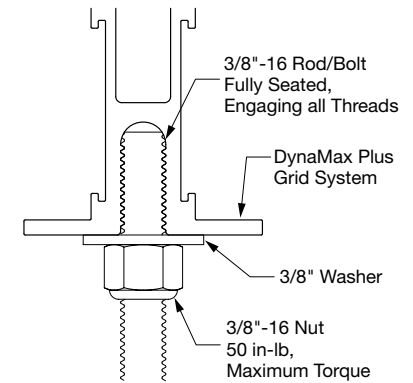



















(Fig 38A)



(Fig 38B)

(Table 1)

NOTE: These panels are specially sized and engineered for the DynaMax® and DynaMax® Plus suspension systems and must be used with the system. These panels do not fit in other suspension systems.

| VISUAL SELECTION | | | PERFORMANCE SELECTION | | | | | | | | | | | | | | |
|---|----------|------------------------|---|--|---|---|---|---|---|---|-----------|-------------|-----------------------------|------------|------------------|-----------------|------------------|
| Edge Profile | Item No. | Dimensions (Inches) | Sound Absorption | + | Sound Blocking | = | Total Acoustics ¹ | Articulation Class | Fire Performance | Light Reflect | Bio-Block | Humi-Guard+ | Certified Low VOC Emissions | Durability | Recycled Content | Recycle Program | 30-Year Warranty |
| | | |  |  |  |  |  |  |  |  | | | | | | | |
| FINE FISSURED™ for DynaMax® & DynaMax® Plus Square Lay-in  | 4126 | 23-1/4 × 23-1/4 × 5/8" | 0.55 | | 35 | | N/A | N/A | Class A | 0.82 | . | . | . | Std | Std | . | . |
| | 4126BL | 23-1/4 × 23-1/4 × 5/8" | 0.55 | | 35 | | N/A | N/A | Class A | N/A | . | . | . | Std | Std | . | . |
| | 4127 | 23-1/4 × 47-1/4 × 5/8" | 0.55 | | 35 | | N/A | N/A | Class A | 0.82 | . | . | . | Std | Std | . | . |
| | 4127BL | 23-1/4 × 47-1/4 × 5/8" | 0.55 | | 35 | | N/A | N/A | Class A | N/A | . | . | . | Std | . | . | . |
| CALLA® for DynaMax & DynaMax Plus Square Lay-in  | 2896 | 23-1/4 × 23-1/4 × 1" | 0.85 | | 35 | | BEST  | 170 | Class A | 0.85 | . | . | . | . | . | . | . |
| | 2896BK | 23-1/4 × 23-1/4 × 1" | 0.85 | | 35 | | BEST  | 170 | Class A | N/A | . | . | . | . | . | . | . |
| | 2897 | 23-1/4 × 47-1/4 × 1" | 0.85 | | 35 | | BEST  | 170 | Class A | 0.85 | . | . | . | . | . | . | . |
| | 2897BK | 23-1/4 × 47-1/4 × 1" | 0.85 | | 35 | | BEST  | 170 | Class A | N/A | . | . | . | . | . | . | . |
| DUNE® for DynaMax & DynaMax Plus Square Lay-in  | 4270 | 23-1/4 × 23-1/4 × 5/8" | 0.50 | | 35 | | N/A | N/A | Class A | 0.85 | . | . | . | . | . | . | . |
| | 4271 | 23-1/4 × 47-1/4 × 5/8" | 0.50 | | 35 | | N/A | N/A | Class A | 0.85 | . | . | . | . | . | . | . |
| ULTIMA® for DynaMax & DynaMax Plus Square Lay-in  | 1807 | 23-1/4 × 23-1/4 × 3/4" | 0.75 | | 35 | | BETTER  | 170 | Class A | 0.88 | . | . | . | . | . | . | . |
| | 1808 | 23-1/4 × 47-1/4 × 3/4" | 0.75 | | 35 | | BETTER  | 170 | Class A | 0.88 | . | . | . | . | . | . | . |
| ULTIMA® AirAssure® for DynaMax & DynaMax Plus Square Lay-in  | 1599 | 23-1/4 × 23-1/4 × 3/4" | 0.75 | | 35 | | BETTER  | N/A | Class A | 0.88 | . | . | . | . | . | . | . |
| | 1638 | 23-1/4 × 47-1/4 × 3/4" | 0.75 | | 35 | | BETTER  | N/A | Class A | 0.88 | . | . | . | . | . | . | . |
| OPTIMA® PB for DynaMax & DynaMax Plus Square Lay-in  | 3210PB | 47-5/16 × 47-5/16 × 1" | 0.95 | | N/A | | N/A | 190 | Class A | 0.88 | . | . | . | . | . | . | . |

MORE INFORMATION

For more information, or for an Armstrong Ceilings representative, call 877 276-7876.

For complete technical information, detail drawings, CAD design assistance, installation information, and many other technical services, call TechLine customer support at 877 276-7876 or FAX 800 572-TECH.

Fantastik® is a registered trademark of the S.C. Johnson & Son, Inc.
All other trademarks used herein are the property of AWI Licensing LLC and/or its affiliates.
© 2024 AWI Licensing Company Printed in the United States of America

BPLA-292229-524



Armstrong®
World Industries