

# FeltWorks® Blades – VarAffix™ Panels

## Assembly and Installation Instructions



### 1. GENERAL

#### 1.1 Product Description

FeltWorks® Blades – VarAffix™ panels are vertical, acoustical felt panels designed to be suspended from a Prelude® XL® 15/16" suspension system in groups, independently from cables/wires, or independently attached to structure with 1/4" – 20 threaded rod. FeltWorks Blades – VarAffix panels are made from polyester felt (PET) fibers, with color throughout, and finished on all edges and surfaces.

FeltWorks Blades – VarAffix panels are available in Rectangular Blades in varying lengths and depths. See the product data page for the dimensions of each panel. For alternative colors and designs tailored to your projects, visit Turf® at [turf.design](http://turf.design)

FeltWorks Blades – VarAffix panels are engineered for use in seismic areas when installed in accordance with these installation instructions. Reference Section 8.0 for more detailed instructions on seismic installations.

#### 1.2 Storage and Handling

FeltWorks Blades – VarAffix panels should be stored in a dry interior location and must remain in the original carton prior to installation to avoid damage. The carton(s) must be stored in a flat, horizontal position. The vertical panels should not be removed from the carton until the suspension system is installed. Proper care should be taken when handling Blades panels to avoid damage and soiling. It is recommended to hold the panels in the vertical orientation to avoid creasing the blade. White cotton or latex gloves are recommended for handling. It is recommended that two installers handle 96" FeltWorks Blades – VarAffix panels.

#### 1.3 Site Conditions

FeltWorks Blades – VarAffix panels can be installed where the temperature is between 40°F (4°C) and 158°F (70°C). Panels cannot be used in exterior applications, where standing water is present, or where moisture will come in direct contact with the FeltWorks Blades – VarAffix panels.

#### 1.4 Fire Performance

FeltWorks Blades – VarAffix panels achieve Flame Spread Index 25 or less. Smoke Developed Index 450 or less. Class A per ASTM E84. FeltWorks Blades – VarAffix panels may obstruct or skew the existing or planned fire sprinkler water distribution pattern, or possibly delay the activation of the fire sprinkler or fire detection system. Designers and installers are advised to consult a fire protection engineer, NFPA 13, and their local code official for guidance on the proper installation techniques where fire detection or suppression systems are present.

#### 1.5 Warranty

The FeltWorks Blades – VarAffix panel systems have been tested based on the installation methods described in this document. Warranty will be voided if you do not follow these instructions and guidelines.

#### 1.6 HVAC Design and Operations and Temperature/Humidity Control

Proper air supply and return air design, maintenance of the HVAC filters, and building interior space are essential to minimize soiling. Before starting the HVAC system, make sure the supply air is properly filtered and the building interior is free of construction dust. FeltWorks Blades – VarAffix panels are for interior use only and cannot be used where standing water is present or where moisture will come in direct contact with the ceiling.

## 1.7 Plenum

FeltWorks® Blades – VarAffix™ panels are installed below the suspension system and do not need to travel above the suspension system during installation. FeltWorks Blades – VarAffix panels allow downward accessibility to the plenum, they can be unattached and reattached to the suspension system or hanging cables.

**NOTE:** Light fixtures and air handling systems require more space and may determine the minimum plenum height for the installation.

## 1.8 Maintenance and Cleaning

### 1.8.1 Dust & Debris Removal

A vacuum or air compressor should be used as needed to remove any dust or debris that may have accumulated. Nozzle attachment tools for vacuums are especially useful when cleaning between blades.

### 1.8.2 Stain Removal

In instances where a wet spill occurs, blot stain immediately with a clean, dry cloth. Do not rub paper products such as facial tissue on the material, as this could result in paper particulate being rubbed into the material. In most cases, a simple solvent of soap and water can be used to remove stains. For more severe instances, household bleach is effective at removing stains. Due to the dyeing process of the fibers, PET felt is able to retain its colorfastness when cleaned with bleach.

Material should air-dry – no heat should be used to speed the drying process.

### 1.8.3 Cleaning

If surfaces are dirty, they should be cleaned using a detergent or soap and water prior to disinfection.

### 1.8.4 Disinfecting

For disinfection, most common EPA-registered household disinfectants should be effective.

- A list of products that are EPA-approved for use against the virus that causes COVID-19 is available at <https://www.epa.gov/coronavirus/about-list-n-disinfectants-coronavirus-covid-19-0>
- Additionally, diluted household bleach solutions (at least 1,000 ppm sodium hypochlorite) can be sprayed on.
- Prepare a bleach solution by mixing 5 tablespoons (one-third cup) bleach per gallon of water.
- Bleach solution will be effective for disinfection up to 24 hours.

## 2. DESIGN AND INSTALLATION CONSIDERATIONS

### 2.1 Directionality

There is a natural fiber direction in the FeltWorks Blades – VarAffix panels, like the graining found in natural wood products. Overall installation designs are non-directional. FeltWorks Blades – VarAffix install on Prelude® XL 15/16" suspension system running parallel to the main beams.

### 2.2 Sprinklers

Standard FeltWorks Blades – VarAffix panels can hang 6"-12" below the face of the suspension bar. Sprinkler heads may need to clear the bottom of the panels depending on the openness of the layout. See the local building code official or fire protection engineer.

### 2.3 Color

There are 12 standard color options for the finished FeltWorks Blades – VarAffix panels, with color throughout the blades. Field painting will void the product warranty. Natural variations in color and grain are characteristic of felt products.

FeltWorks Blades – VarAffix panels are manufactured in dye lots. Panel color and texture may vary from order to order; adequate attic stock should be ordered. Otherwise, orders and materials from separate dye lots may have an unacceptable color variance. If orders must be placed at separate times, it is recommended to install the material from the separate orders in different areas of the project.

Contact TechLine customer support, Architectural Specialties, or an Armstrong representative for additional information.

### 2.4 Blades Panel Layout

FeltWorks Blades – VarAffix panels are available in a variety of lengths and depths with three different installation options. When installing with Prelude XL 15/16" suspension system panels will have a 1" gap between the ends of panels for best visual. Blades will also be limited to a minimum blade spacing of 2-3/16" due to the minimum spacing between the Threaded Grid Clip (Item 6701).

For the best visual, it's recommended to match the spacing of the blade to the height of the blade regardless of the installation method used. Refer to Section 4.2 for individually hung to structure with aircraft cables, Section 4.3 for individually hung to structure with 1/4" – 20 threaded rod, or Section 4.4 for group installation with Prelude® 15/16" suspension system.

## 2.5 Accessibility

FeltWorks® Blades – VarAffix™ panels allow downward accessibility to the plenum. FeltWorks Blades – VarAffix panels are vertically attached to Prelude® suspension system, individually hung to structure via aircraft cables or 1/4" – 20 threaded rods. When blades are installed on the suspension system, aircraft cable, or threaded rod, the blades can be removed for access into the plenum. Make sure to place the blades on a clean surface once they are removed.

## 2.6 Product Classification

FeltWorks Blades – VarAffix panels are classified as an “architectural element” (no bracing is needed) when installed individually using aircraft cables. This means the system:

- Must be able to swing 360 degrees
- Must not be able to come in contact with essential components in the ceiling
- Since aircraft cables are used, the maximum swing that can be expected is 18"

## 3. ACCESSORIES

### 3.1 Item 6701\_\_ – Threaded Grid Clip for VarAffix (Fig 1)

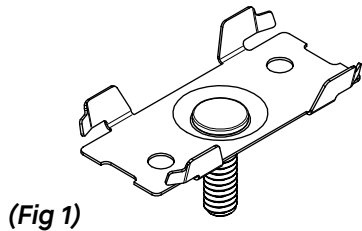

### 3.2. Item 5450 – Cable Suspension Kit (Fig 2)

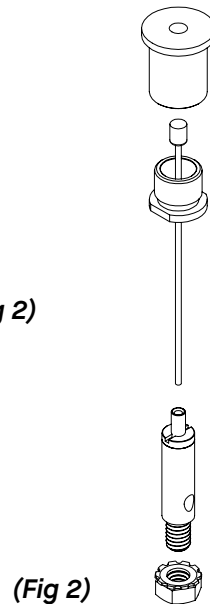

### 3.3. Item 6371MF – Field-Cut Connector Kit (Fig 3) for FeltWorks Blades – VarAffix panels

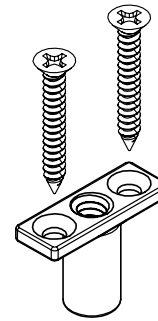

(Fig 3)

### 3.4. 625530 – Extended Hanging Cables (30' Aircraft Cable)

### 3.5. 7121 – Angled Hanging Adaptor (60° maximum angle) (Fig 4)

(Fig 4)

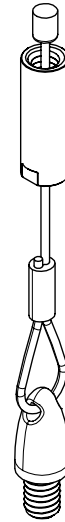

## 4. SUSPENSION SYSTEM

The requirements listed here represent the manufacturer's minimum acceptable installation recommendations and may be subject to additional requirements established by the local authority having jurisdiction. The suspension system chosen must be fastened to the structure per code in the installed location.

- All installations should follow ASTM C636
- All references to suspension component duty ratings are per ASTM C636
- The suspension system chosen must be fastened to the structure per code in your area

### 4.1 Suspension Options

There are 3 different suspension options for use with FeltWorks Blades – VarAffix panels. These methods are:

- Independently suspended from structure with aircraft cable (Item 5450 Cable Suspension Kit)
- Independently suspended from structure with 1/4"-20 threaded rod (by others)
- On Prelude® XL® 15/16" suspension system in a standard 2' x 4' grid layout with Threaded Grid Clip (Item 6701)

## 4.2 Independent Suspension from Structure

### 4.2.1. With Aircraft Cable

FeltWorks® Blades – VarAffix™ panels can be independently suspended using aircraft cables and quick-release bottom end cable adjusters (Fig 5).

Deck Hanging Kit (Item 5450) includes:

- (2) Gripper Structure Anchors
- (2) Gripper Structure Caps
- (2) 8' aircraft cables
- (2) Bottom End Cable Gripper
- (2) Nuts with washers – nuts and washers in the hanging kit are not needed for installation and can be discarded.

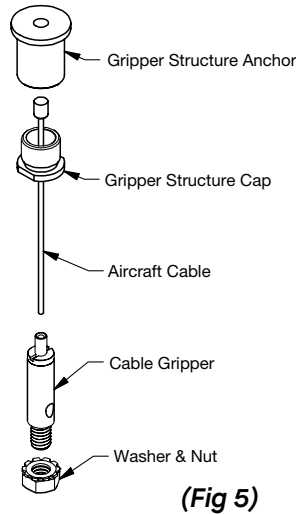

(Fig 5)

**NOTE:** For layout considerations in a seismic installation, refer to Section 8.

- Determine the location to hang the FeltWorks Blades – VarAffix panels
- To fasten the cable connectors to the structure, use fasteners by others that are compatible with the structure. This part of the installation will utilize the Gripper Structure Anchor and Cap from the Deck Hanging Kit (Item 5450)
- Cables will attach every 24" O.C. on the blade
- A minimum of two hanging points is required

1. Fasten cable connectors into the threaded holes at the blade panels' specific attachment points and configure the cable connectors as shown in (Figs 6 & 7).

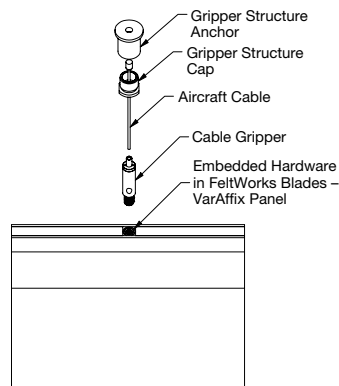

(Fig 6)

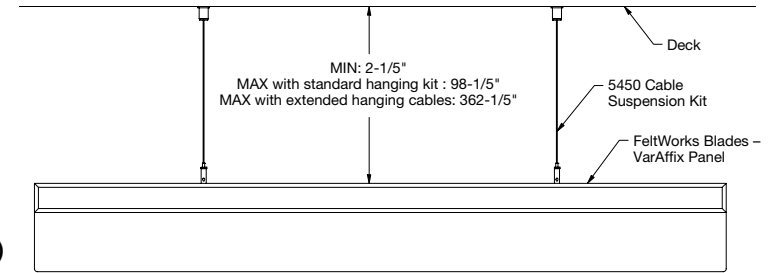

(Fig 7)

With the exception of the washer and nut, these will not be needed for installation and can be discarded. The height of a blade panel can be adjusted at the bottom end of the cable gripper. When a final height is determined and installation is complete, cut off the excess cable wire from the side of the cable gripper leaving a 1" tail.

2. To release the cable and lower the FeltWorks Blades – VarAffix panel, take all weight off the gripper, push the release mechanism, and simply slide the cable out as needed.

**NOTE:** An 8' aircraft cable is included in the standard Deck Hanging Kit. If additional cable length is needed for high ceiling applications, order the Extended Hanging Cables Kit (Item 625530), which has (4) 30' aircraft cables per kit.

For angled hanging applications up to 60 degrees, use the Angled Hanging Adaptor (Item 7121), which has (2) angled hanging cables per kit. To install, insert the angled hanging cable between the bottom end cable gripper of the deck hanging kit and the threaded hole on the blade panel (Figs 8 & 9).

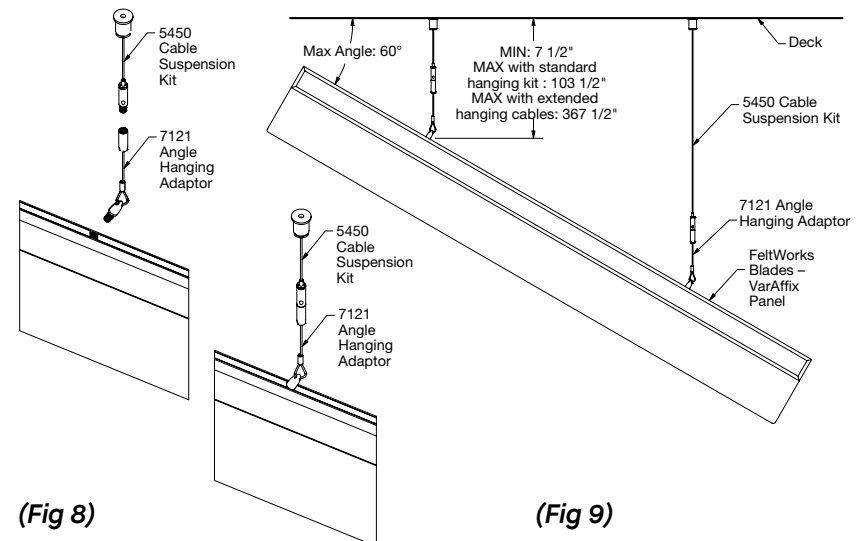

(Fig 8)

(Fig 9)

#### 4.2.2. With 1/4"-20 Threaded Rod (by others)

FeltWorks® Blades – VarAffix™ panels can be independently suspended via 1/4"-20 threaded rod connections to the structure.

##### 4.2.2.1 Installation Consideration:

Lay out the space, marking the locations of the hanger rods, and note any mechanicals that will be supported overhead. Threaded hanger rods must be installed plumb. If plumb threaded rod drops are not possible, then a trapeze or sub-framing may be required. This trapeze or sub-framing must be engineered to support the designed loads. Install 1/4"-20 threaded rod hangers from deck per the recommendations from the deck anchor manufacturer.

The following must be kept in mind when cutting the threaded rod from deck to achieve the desired finished ceiling height:

- The height of the FeltWorks Blades – VarAffix panels
- 1/4"-20 Right-Handed (RH) threaded rod will insert into threaded hole on the blade about 3/4" deep. The length of this RH threaded rod will be determined by the installer.

**4.2.2.2** The following are two recommended options for fastening the RH threaded rod that is inserted into the blade to the threaded rod hanging from the deck. It is the responsibility of the installer to evaluate and choose the threaded rod installation method that will work best for their installation.

Using Coupling Nut (**Figs 10 & 11**):

- 1/4"-20 RH threaded Rod
- Fully Threaded RH Coupling Nut for 1/4"-20 thread
- RH hex nuts for 1/4"-20 thread

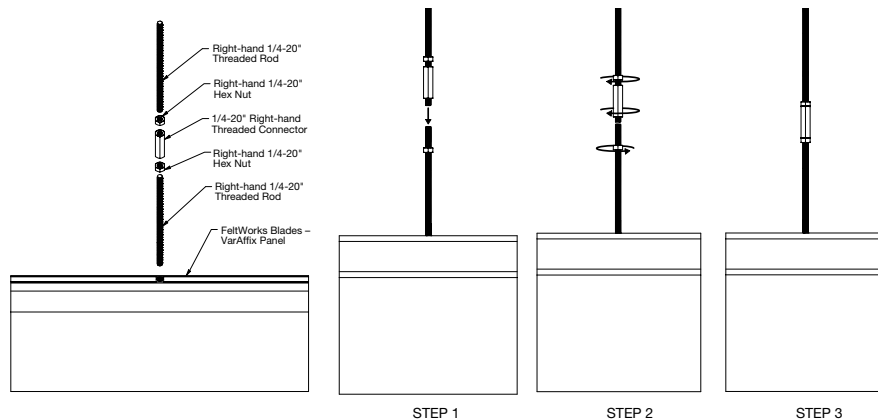

(Fig 10)

(Fig 11)

#### Using a Turnbuckle (**Figs 12 & 13**):

- 1/4"-20 Left-Hand to Right-Hand threaded adapter.
- Turnbuckle for 1/4"-20 thread
- LH hex nut for 1/4"-20 thread
- RH hex nut for 1/4"-20 thread

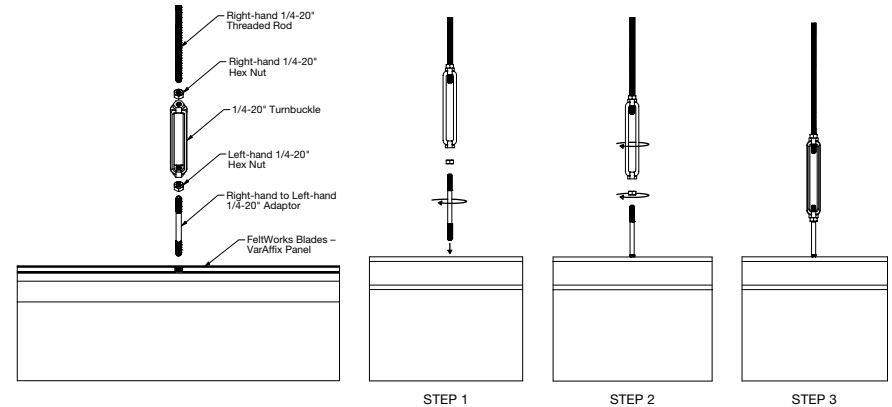

(Fig 12)

(Fig 13)

**NOTE:** A minimum of 3/4" of thread will need to be inserted into the turnbuckle or coupling nut and require hex nuts to get a secure connection.

**4.2.2.3** With threaded rod installation, blades 96" and under will require a minimum of two hanging points. 10' blades will require a minimum of three hanging points. There must also be a threaded rod connection within 12" from the end of a blade.

## NON-SEISMIC INSTALLATION

### 4.3 Group Installation with Standard Prelude® XL® 15/16" Suspension System

FeltWorks Blades – VarAffix panels can be installed on Prelude XL 15/16" suspension systems or 360° Painted Grid using Threaded Grid Clip (Item 6701) which snap onto the flange of the grid.

#### 4.3.1. System Components

FeltWorks Blades – VarAffix panels can be installed on Intermediate Duty or Heavy-duty Prelude XL 15/16" suspension systems. For Seismic Design Category C, D, E, and F installations refer to Section 8. Cross tees must have XL end details and be at least Intermediate Duty Equivalent (12 lbs/LF).

New installations that will include mineral fiber or fiberglass acoustical panels in addition to FeltWorks® Blades – VarAffix™ panels may require Heavy-duty main beams and Heavy-duty Equivalent (HDE) cross tees. This is based on the total system weight and the grid layout (e.g. 2' x 4' vs. 4' x 4').

For alternative layouts, calculate the carrying capacity requirements based on the total system weight to determine if a Heavy-duty grid system is needed. If the total system weight exceeds 3 lbs/SF, a Heavy-duty grid system is needed.

**For New or Existing Grid:** FeltWorks Blades – VarAffix panels installed on a new or existing grid, with or without acoustical panels in place, must ensure the following conditions are met:

- Grid must be installed per ASTM C636
- Grid must be 15/16" Prelude
- Grid must meet the proper load classification to carry the FeltWorks Blades – VarAffix panels and any mineral fiber or fiberglass acoustical panels (if applicable)
- Specific instructions regarding the placement of Threaded Grid Clip (Item 6701) along the panels are noted in Section 6.2.

#### 4.3.2. Suspension Rules for All Layouts

- Main beams must be installed within 24" of the perimeters and then at 48" O.C.
- Hanger wires must be installed within 24" of the perimeters and no more than 48" O.C.
- The Rigid Attachment Clip (6459BL available in black) can be substituted for hanger wires in up-tight-to-deck installations and must follow the same rules for spacing.

#### 2' x 4' Layout (Figs 14 & 15)

Main beams (7300 or 7301) installed at 48" O.C. with 4' cross tees (XL7340 or XL7341) perpendicular to the main beams at 24" O.C.

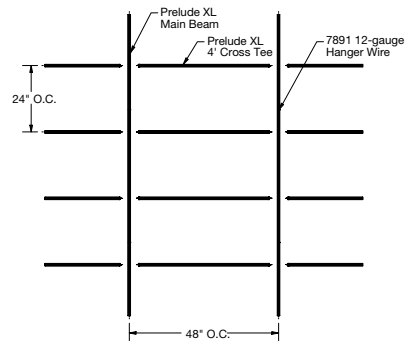

(Fig 14)

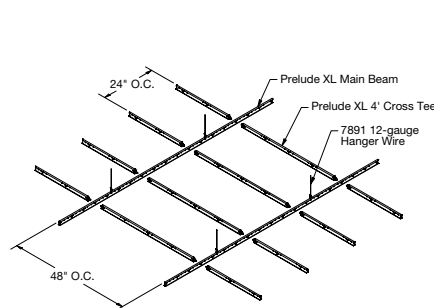

(Fig 15)

4' cross tees must match the main beams in load-carrying capacity. Exception for 360° Painted Grid which has Intermediate-Duty Equivalent 4' cross tees (XL734036) and will not be installed with additional panels.

#### Wall-to-Wall Perimeter Options

Although angle molding (7800) is usually the preferred perimeter trim, there are no special requirements for wall molding type or installation method.

## 5. FLOATING PERIMETER / DISCONTINUOUS SYSTEMS

For discontinuous grid installations, Axiom® trim can be used to provide a professional, finished aesthetic around the grid. It is recommended that Axiom interfaces at the grid level because FeltWorks Blades – VarAffix panels hang at various elevations below the face of the grid system (Figs 16 & 17).

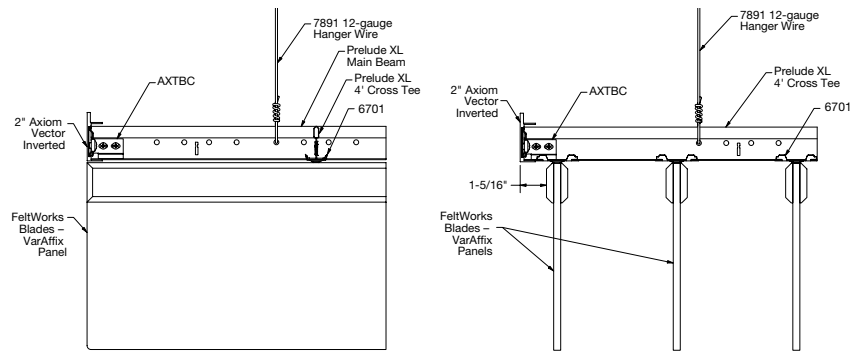

(Fig 16)

(Fig 17)

## 6. FELTWORKS BLADES – VARAFFIX PANELS TO SUSPENSION SYSTEM

### 6.1. Threaded Grid Clip Attachment

FeltWorks Blades – VarAffix panels are attached to 15/16" Prelude® XL® or 360° Painted Grid using the Threaded Grid Clip (Item 6701) (Fig 18).

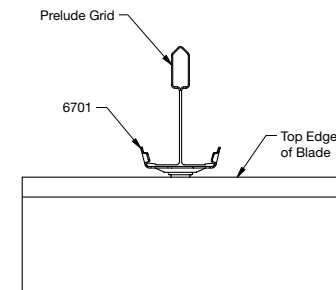

(Fig 18)

Safety gloves are recommended when handling the clips. Each blade panel has attachment points at 24" O.C. for installation. Without the use of tools, thread the threaded stud into the threaded hole on the FeltWorks® Blades – VarAffix™ by hand, the threaded stud should end in a perpendicular position to the blade length (**Figs 19 & 20**).

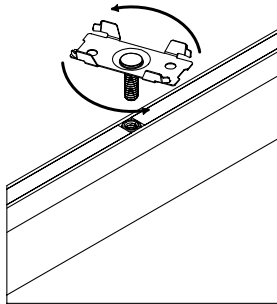

(Fig 19)

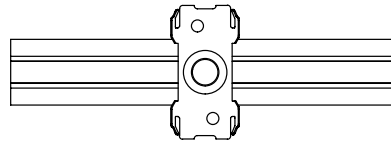

(Fig 20)

The Threaded Grid Clip (Item 6701) can rotate to align with the grid and is then snapped onto the flange of the cross tees. Make sure that all four corner tabs of the clip securely snap into place on the grid flange (**Fig 21**).

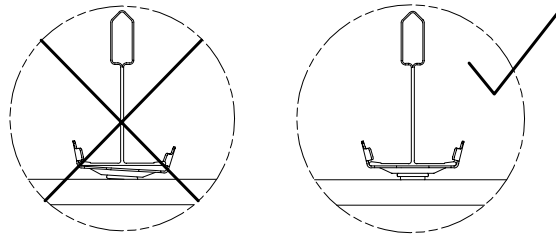

(Fig 21)

## 6.2. Clip Guidelines

- A minimum of two Threaded Grid Clip is required on each FeltWorks Blades – VarAffix panel, as defined by the blade's size and connection points
- Threaded Grid Clip must be within 23" from the end of any size blade – (Recommend cuts should be made in 6" increments to match grid/new cross tee connection for additional tees that may be required)

**NOTE:** Seismic installations have additional requirements for Threaded Grid Clip connections to the grid. See Section 8.4 for further information.

## 6.3. Minimum Blade – Panel-to-Panel/Clip-to-Clip Spacing

Due to the clips' overall size, the minimum spacing between the two clips is approximately 2-3/16" (**Fig 22**). Refer to Section 2.4 for design consideration – blade layout spacing.

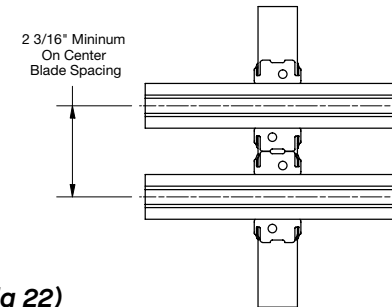

(Fig 22)

## 6.4 Installing FeltWorks Blades – VarAffix Panels on the Grid with Acoustical Ceiling Panels Installed (square lay-in panels only) (Fig 23)

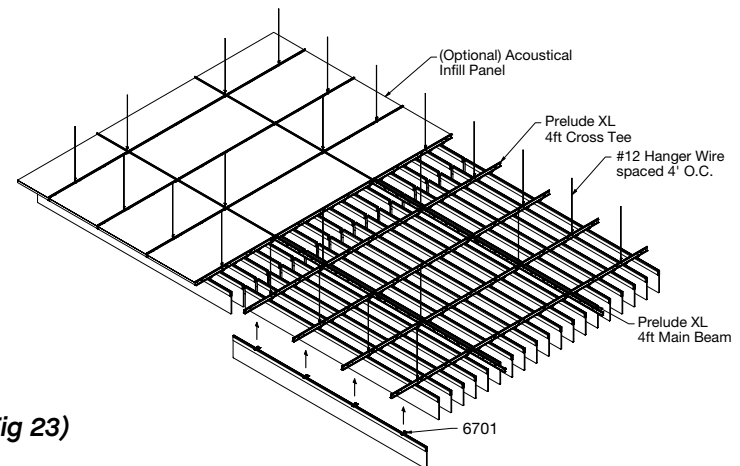

(Fig 23)

- FeltWorks Blades – VarAffix panels can only be installed in conjunction with square lay-in panels. Panels that drop below the grid face will interfere with the Threaded Grid Clips
- Align the FeltWorks Blades – VarAffix panels and Threaded Grid Clip with the grid and then snap it onto the flange of the grid. Make sure that all four corner tabs of the clip securely snap into place over the grid flange

- While holding the clip against the grid face, press down on the acoustical panel to ensure that it is level and flush with the flange of the grid. Holding the clip against the grid face as you push down the acoustical panel will ensure clip does not disengage from the grid flange. **NOTE:** The clip will pierce the face of the acoustical panel. Facial marring is hidden by the clip and the FeltWorks® Blades – VarAffix™ panels when installed.

## 6.5. Cutting Blade Panels

FeltWorks Blades – VarAffix panels may be cut with a variety of tools, depending on the type and precision of cut required. Tool speeds and the angle of the cut should be such that the panel does not melt from frictional heat. In general, the highest speed at which overheating of the tool or panel does not occur will give the best results.

### 6.5.1. The following tools can be used to make cuts in the field:

- Hand tools such as insulation cutting knives, snap-away utility knives, and straight knives can be used for straight or circular cuts. 3-4 passes may need to be made to cut through the material. Ensure the blade is long enough to cut through the material to prevent poor edge quality.
- Circular saw: can be used for straight cuts. Be sure to use a 7-1/4" foam blade, such as Bullet Tools™ CenterFire™ or equal, or a non-ferrous/plastic blade, such as Diablo® D0756N or equal. Utilize a straight edge to guide the circular saw to ensure the cut edge remains straight. Constant feed rate is critical to limit panel melting on the cut edge. When using the circular saw, make sure the blade comes to a complete stop before backing the saw out of the cut.

**6.5.2.** Make sure the FeltWorks Blades – VarAffix panel is supported on a clean surface when making cuts to minimize the risk of blemishes or melting on the cut face.

**6.5.3.** It is recommended that the same cutting blade is not used when cutting panels that have different colors to minimize the risk of transferring colored fibers between panels. If you only have one cutting blade, mineral spirits (or other similar solvents) can be used to clean the cutting blade with steel wool.

**6.5.4.** Make sure the cutting blade is kept clean and sharp to insure optimal cuts.

**6.5.5.** If a FeltWorks Blades – VarAffix panel is cut down in size, it will need at least two connection points for hanging. To add an additional hanging point to the blade panel the FeltWorks Blades – VarAffix panels connector kit (Item 6371MF) will be required. Follow the 5 steps to fasten to the blade panel (**Fig 24**).

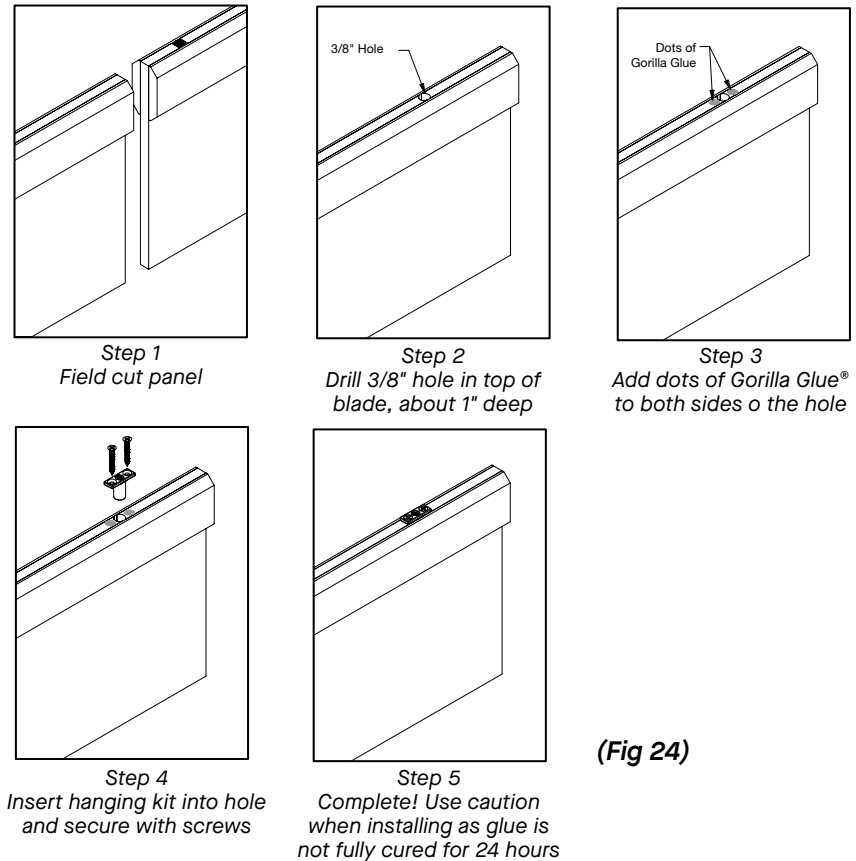

(Fig 24)

- Cut the FeltWorks Blades – VarAffix panel to the desired length
- Drill 3/8" hole to the top of the blade, about 1" deep and within 23" but no less than 3" from the cut end. **IMPORTANT NOTE:** A brad point drill bit is recommended, to minimize shifting of the drill bit and keep it centered on the correct drilling spot for the threaded connector. This is more critical when using either the Threaded Grid Clip (Item 6701) to Prelude® XL® 15/16" or threaded rod installation method.
- Add dots of Gorilla Glue® to both sides of the hole
- Insert the threaded connector into the 3/8" hole and fasten it with the provided screws
- Once complete, use caution when installing as the glue is not fully cured for 24 hours



## 7. SPECIALTY INSTALLATION CONSIDERATIONS

### 7.1 Sloped Installation

The following rules apply to sloped installations for FeltWorks® Blades – VarAffix™ and are based on the installation method:

#### 7.1.1 Independent Suspension with Hanging Kit

FeltWorks Blades – VarAffix panels can be angled up to 60 degrees using the Angled Hanging Adaptor (Item 7121). This has been tested and approved in all Seismic Design Categories.

#### 7.1.2. Attached to Prelude® 15/16" Grid

FeltWorks Blades – VarAffix panels should not be installed on a sloped grid. This applies to all Seismic Design categories

### 7.2 Product Classification

FeltWorks Blades – VarAffix panels are classified as an “architectural element” (no bracing is needed) when installed using aircraft cables. This means the system:

- Must be able to swing 360 degrees
- Must not be able to come in contact with essential components in the ceiling
- Since aircraft cables are used, the maximum swing that can be expected is 18"

### 7.3 MEP Integration

Mechanical fixtures such as lights, speakers, and sprinklers can be installed at the suspension system height, flush with the bottom or below the bottom of the FeltWorks Blades – VarAffix panels (refer to Section 2.2 for sprinkler considerations). Fixture weight or housing must not be supported by the FeltWorks Blades – VarAffix panels.

### 7.4 Exterior Installations

FeltWorks Blades – VarAffix panels cannot be installed in exterior applications.

## 8. SEISMIC INSTALLATION

For more details on seismic installations please see our brochure: *Seismic Design: What You Need to Know*.  
<https://www.armstrongceilings.com/content/dam/armstrongceilings/commercial/north-america/brochures/seismic-design-what-you-need-to-know-brochure.pdf>

### 8.1. Aircraft Cable Installation:

The International Building Code states the ceiling system connection to the structure must allow the ceiling to move 360° in horizontal plane. FeltWorks Blades – VarAffix panels suspended individually with aircraft cable must be spaced a minimum of 6" apart or from surrounding surfaces to avoid contact during a seismic event.

### 8.2. Grid Suspension System:

- All seismic installations of FeltWorks Blades – VarAffix panels must be installed per Seismic Categories D, E, F. This is regardless of the total system weight.
- Prelude® 15/16" Heavy-duty grid system is required per ASTM E580 and the cross tees may have to match the mains in load-carrying capacity based on the grid layouts as defined in Section 4.4.
- FeltWorks Blades – VarAffix panels attached to the grid have been engineered for application in all seismic areas.

### 8.3. Seismic Rx® Suspension System Category D, E, and F Requirements (All Seismic Installations)

- FeltWorks Blades – VarAffix panels must be spaced a minimum of 6" O.C. apart and from surrounding surfaces to avoid contact during a seismic event
- Ceiling installation should conform to basic minimums established in ASTM C636.
- Minimum 7/8" wall molding – suspension system must be attached on two adjacent walls
- Opposite walls require BERC2 with 3/4" clearance
- BERC2 maintains main beam and cross tee spacing; no other components are required
- Heavy-duty systems as identified in ICC-ESR-1308
- Safety wires are required on light fixtures
- Perimeter support wires within 8"
- Ceiling areas over 1,000 SF must have horizontal restraint wire or rigid bracing
- Ceiling areas over 2,500 SF must have seismic separation joints or full-height partitions
- Ceilings without rigid bracing must have 2" oversized trim rings for sprinklers and other penetrations
- Changes in the ceiling plane must have positive bracing

- Cable trays and electrical conduits must be independently supported and braced
- Suspended ceilings will be subject to special inspection
- Suspension layouts
- Suspension layouts are the same as described in Section 4.4: Suspension System
- Connection to the wall – See BPCS-4141 *Seismic Design: What You Need to Know – Code Requirements Seismic Rx® Suspension System Tested Solutions – Seismic Rx Approaches To Category C And D, E, And F Installations*
- Special bracing required – See BPCS-4141 *Seismic Design: What You Need to Know – Code Requirements Seismic Rx Suspension System Tested Solutions – Bracing and Restraint for Seismic Installations*
- Seismic separation joints – See BPCS-4141 *Seismic Design: What You Need to Know – Code Requirements Seismic Rx Suspension System Tested Solutions – Seismic Separation Joints*

*Seismic reaction information is based on full-scale testing and computer modeling conducted at the Structural Engineering Earthquake Simulation Lab located at the State University of New York at Buffalo.*

#### **8.4. FeltWorks® Blades – VarAffix™ Panel Attachment (Figs 25 & 26)**

The minimum spacing between FeltWorks® Blades – VarAffix™ panels for Seismic Design Categories D, E, and F is 6" O.C.

After installing the FeltWorks Blades – VarAffix panel (or a run of vertical panels) to the suspension system, ensure correct positioning of the panel and add two screws through the pilot hole on the Threaded Grid Clip (Item 6701) through the face of the grid. This will secure the clip to the suspension system.

**NOTE:** The use of a long shaft adapter may be necessary to install this screw.

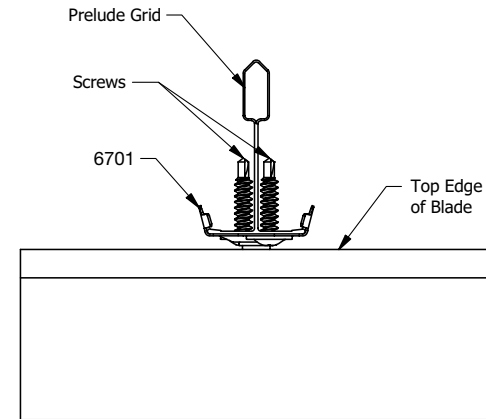

(Fig 25)

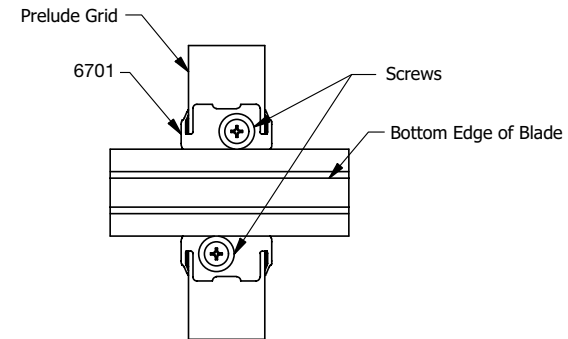

(Fig 26)

<b>FELTWORKS® BLADES – VARAFFIX™ PANEL ITEMS</b>						
<b>Item No.</b>	<b>Description – Sizes are Nominal not Exact</b>	<b>Ordered Separately/ Included with</b>	<b>Required for Install</b>	<b>Pcs/ Ctn</b>	<b>Lbs Per Panel</b>	<b>Lbs Per LF</b>
637ORCE0004_ _ _	6" x 4'	Ordered Separately	Based on Design	12	1.83	0.45
637ORCE0007_ _ _	6" x 6'	Ordered Separately	Based on Design	12	2.5	0.42
637ORCE0001_ _ _	6" x 8'	Ordered Separately	Based on Design	12	3.67	0.46
637ORCE0008_ _ _	6" x 10'	Ordered Separately	Based on Design	12	4.33	0.43
637ORCE0009_ _ _	8" x 4'	Ordered Separately	Based on Design	12	2	0.5
637ORCE0010_ _ _	8" x 6'	Ordered Separately	Based on Design	12	2.75	0.42
637ORCE0011_ _ _	8" x 8'	Ordered Separately	Based on Design	12	4	0.5
637ORCE0012_ _ _	8" x 10'	Ordered Separately	Based on Design	12	4.83	0.48
637ORCE0013_ _ _	10" x 4'	Ordered Separately	Based on Design	12	2.25	0.56
637ORCE0014_ _ _	10" x 6'	Ordered Separately	Based on Design	12	3.17	0.53
637ORCE0015_ _ _	10" x 8'	Ordered Separately	Based on Design	12	4.5	0.56
637ORCE0016_ _ _	10" x 10'	Ordered Separately	Based on Design	12	5.42	0.54
637ORCE0017_ _ _	12" x 4'	Ordered Separately	Based on Design	12	2.58	0.65
637ORCE0018_ _ _	12" x 6'	Ordered Separately	Based on Design	12	3.67	0.61
637ORCE0019_ _ _	12" x 8'	Ordered Separately	Based on Design	12	5.25	0.66
637ORCE0020_ _ _	12" x 10'	Ordered Separately	Based on Design	12	6.25	0.63
<b>FELTWORKS BLADES – VARAFFIX PANEL SUSPENSION &amp; ACCESSORIES</b>						
<b>For Group Suspension Intermediate Duty</b>						
7300	Prelude® XL® 12' ID Main Beam	Ordered Separately	Yes	20		
XL7340	Prelude XL 4' Cross Tee	Ordered Separately	Yes	60		
7891	12-gauge Hanger Wire	Ordered Separately	Yes	Bulk		
7800	Angle Wall Molding	Ordered Separately	Based on Design	360		
6701_ _	Threaded Grid Clip for VarAffix	Ordered Separately	Yes	80		
<b>For Group Suspension Heavy Duty</b>						
7301	Prelude XL 12' HD Main Beam	Ordered Separately	Yes	20		
XL7341	Prelude XL 4' Cross Tee	Ordered Separately	Yes	60		
7891	12-gauge Hanger Wire	Ordered Separately	Yes	Bulk		
7800	Angle Wall Molding	Ordered Separately	Based on Design	360		
6701_ _	Threaded Grid Clip for VarAffix	Ordered Separately	Yes	80		
<b>Floating Perimeter Trim</b>						
AX_STR_ _ _	Axiom® Classic Straight Trim	Ordered Separately	Based on Design	10 Lft		
7239	Adjustable Trim Clip (ATC)	Ordered Separately	Based on Design	1		
<b>For Individual Suspension</b>						
5450	Cable Suspension Kit	Ordered Separately	Yes	2		
625530	Extended Hanging Cables (30' Aircraft Cable)	Ordered Separately	Based on Design	4		
7121	Angled Hanging Adaptor (60° maximum angle) – Extends from the end of Deck Hanging Kit (5450)	Ordered Separately	Based on Design	2		
<b>Other Accessories</b>						
6371MF	FeltWorks Blades – VarAffix Field-Cut Connector Kit	Ordered Separately	Based on Design	10		
BERC2	2" Beam End Retaining Clip	Ordered Separately	Based on Design	200		
6459BL	The Rigid Attachment Clip	Ordered Separately	Based on Design	2		

---

## **MORE INFORMATION**

For more information, or for an Armstrong Ceilings representative, call 877 276-7876.

For complete technical information, detail drawings, CAD design assistance, installation information, and many other technical services, call TechLine customer support at 877 276-7876 or FAX 800 572-TECH.

Bullet Tools™ and CenterFire™ are trademarks of Bullet Tools; Diablo® is a registered trademark of Diablo Tools; Turf® is a registered trademark of Turf Design, Inc.; Gorilla Glue® is a registered trademark of Gorilla Glue Company; all other trademarks used herein are the property of AWI Licensing LLC and/or its affiliates.

© 2023 AWI Licensing Company Printed in the United States of America

BPLA-293354-423

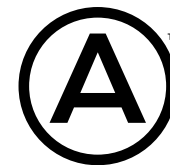

**Armstrong®**  
World Industries