

FELTWORKS® Open Cell

Assembly and Installation Instructions

DO NOT REMOVE FELTWORKS OPEN CELL PANELS FROM THE CARTON UNTIL THESE INSTRUCTIONS HAVE BEEN READ IN THEIR ENTIRETY.

1. GENERAL

1.1 Product Description

FeltWorks® Open Cell panels are vertical, acoustical felt panels designed to be inserted together to create 12" x 12" square cells. The panels are suspended independently from aircraft cables with the Hanging Kit (item 6655). FeltWorks Open Cell panels are made from polyester felt (PET) fibers, with color throughout, and are finished on all edges and surfaces.

FeltWorks Open Cell panels are available in Rectangular Kits, Ebbs and Flows Kits, and Peaks and Valleys Kits. See the product's data page for dimensions of each panel. Additionally, custom shaped and sized panels can be ordered through the ASQuote@armstrongceilings.com.

There are 15 standard color options for FeltWorks Open Cell panels. Field painting will void the product warranty.

FeltWorks Open Cell panels are engineered for use in seismic areas when installed in accordance with these installation instructions. Reference section 6.0 for more detailed instructions on seismic installations.

These installation instructions are specific to the FeltWorks Open Cell product. Please refer to the specific instructions for our other FeltWorks products if installing those products. Visit armstrongceilings.com/feltworks for more information.

1.2 Storage and Handling

FeltWorks Open Cell panels shall be stored in a dry interior location and shall remain in the original carton prior to installation to avoid damage. The carton(s) shall be stored in a flat, horizontal position. The vertical panels should not be removed from the carton until the suspension system is installed. Proper care should be taken when handling the panels to avoid damage and soiling. It is recommended to hold the

panels in the vertical orientation to avoid creasing. White cotton or latex gloves are recommended for handling. It is recommended that two installers handle 96" panels.

1.3 Site Conditions

FeltWorks Open Cell panels can be installed where the temperature is between 40°F (4°C) and 158°F (70°C). Panels cannot be used in exterior applications, where standing water is present, or where moisture will come in direct contact with the panel.

1.4 FeltWorks Open Cell Panel Layout

FeltWorks Open Cell panels are available in a variety of lengths and designs and are able to be suspended independently from aircraft cables using the Hanging Kit (item 6655) to create a modular, cellular design. The forming process for FeltWorks panels is similar to textile forming, creating a soft visual. Please note that panels have a 1/4" gap between ends of panels for best visual due to potential bowing.

1.5 Fire Performance

FeltWorks Open Cell achieve Flame Spread Index of 25 or less, and Smoke Developed Index of 450 or less. They are Class A per ASTM E84. FeltWorks Open Cell panels may obstruct or skew the existing or planned fire sprinkler water distribution pattern, or possibly delay the activation of the fire sprinkler or fire detection system. Designers and installers are advised to consult a fire protection engineer, NFPA 13, and their local code official for guidance on the proper installation techniques where fire detection or suppression systems are present.

1.6 Warranty

The FeltWorks Open Cell systems have been tested based on the installation methods described in this document. Warranty will be voided if you do not follow these instructions and guidelines.

1.7 HVAC Design/Operation and Temperature/ Humidity Control

Proper design for both air supply and return air, maintenance of the HVAC filters, and building interior space are essential to minimize soiling. Before starting the HVAC system, make sure the supply air is properly filtered and the building interior is free of construction dust. FeltWorks Open Cell panels are for interior use only and cannot be used where standing water is present or where moisture will come in direct contact with the ceiling.

1.8 Cleaning

Use a clean, dry, soft, white cloth to wipe off any dust or fingerprints. A vacuum can also be used to remove dirt from the panels. Vacuum cleaner brush attachments, such as those designed for cleaning upholstery or walls, do the best job. Be certain to clean in one direction only to prevent rubbing dust into the face of the panel. If this does not clean the panel, use a damp, clean, soft, white cloth or sponge with a mild detergent to wipe the panel. Remove any remaining moisture with a dry cloth.

2. DESIGN CONSIDERATIONS

2.1 Directionality

There is a natural fiber direction in the FeltWorks Open Cell panels, similar to the graining found in natural wood products. Overall installation designs are non-directional.

2.2 Sprinklers

FeltWorks Open Cell panels may obstruct or skew the existing or planned fire sprinkler water distribution pattern, or possibly delay the activation of the fire sprinkler or fire detection system. Designers and installers are advised to consult a fire protection engineer, NFPA 13, and their local code official for guidance on the proper installation techniques where fire detection or suppression systems are present.

Standard FeltWorks Open Cell panels can hang 3" – 12" below the connection point to the Hanging Kit. Sprinkler heads may need to clear the bottom of the panels depending on the openness of the layout. See local building code official or fire protection engineer.

2.3 Colors

There are 15 standard color options for the FeltWorks Open Cell panels. Field painting will void the product warranty. Variations in color and texture are natural characteristics of felt products. These are through color panels.

FeltWorks Open Cell panels are manufactured in dye lots. Panel color and texture may vary from order to order and from panel to panel;

adequate attic stock should be ordered. Otherwise, orders and materials from separate dye lots may have an unacceptable color variance. If orders must be placed at separate times, it is recommended to install the material from the separate orders in different areas of the project.

2.4 Plenum

FeltWorks Open Cell panels allow accessibility to the plenum. The panels can be unattached and reattached to the Hanging Kits (item 6655).

The Bottom panels are installed first and define the installation height. The Mid and Top panels will need to travel above the Bottom panels during installation. In situations where there are obstructions above the finished height that will interfere with the installation of the Mid and Top panels, install the system 3" – 4" below the intended finished height. Do not install the entire system lower than 6" below the intended finished height due to the movement and misalignment caused to the panels as the finished system is raised.

NOTE: Light fixtures and air handling systems require more space and may determine the minimum plenum height for the installation.

2.5 Approximate System Weight and Attachment to Deck

FeltWorks Open Cell panels have an approximate weight of 0.33 lbs/SF. Regardless of weight, additional hanging points will more than adequately hold the weight of the system.

- S8 Kit - 12" Deep Rectangles – 41.7 lbs.
- R8, R4 & S4 Kits – 12" Deep Rectangles – 20.8 lbs.
- S8 Kits - Ebbs & Flows / Peaks & Valleys / 6" Deep Rectangles – 20.6 lbs.
- R8, R4 & S4 Kits - Ebbs & Flows / Peaks & Valleys / 6" Deep Rectangles – 10.3 lbs.

Hanging connections to the ceiling structure must follow the fastener manufacturer's instructions and referenced code based on the system weight and structure into which the suspension system will be fastened. If custom panels are being installed, the installer will need to calculate the lbs/SF based on the layout.

2.6 Accessibility

FeltWorks Open Cell panels are vertically suspended panels. When installed on the Hanging Kits (item 6655), the panels can be removed to create a 24" x 36" opening for access into the plenum.

The open cell design can also be disassembled if needed. Make sure to place the panels on a clean, level surface that supports the entire length of the panel once they are removed. This will help to minimize any soiling and bowing/creasing.

2.7 Cutting FeltWorks Open Cell Panels

FeltWorks Open Cell panels may be cut with a variety of tools, depending on the type and precision of cut required. Tool speeds and the angle of the cut should be such that the panel does not melt from frictional heat. In general, the highest speed at which overheating of the tool or panel does not occur will give best results.

2.7.1 The following tools can be used to make cuts in the field:

Hand Tools: can be used for straight or circular cuts. Tools that have proven performance include: insulation cutting knife, snap-away utility knife, straight knife, ceramic utility knife.

- 3 – 4 passes may need to be made to cut through the material
- Ensure cutting blade is long enough to cut through the material to prevent poor edge quality
- Utilize a straight edge to guide the hand tool to ensure the cut edge remains straight.

Jig saw: recommended for complex cuts such as circles that would need to be made to maneuver around pipes, sprinkler heads, and other fixtures in the field. If a jig saw is to be used for a straight cut, utilize a straight edge to guide the jig saw to ensure the cut edge remains straight. Be sure to use a foam knife edge blade when using the jigsaw, such as Bosch T313AW or equal.

Circular saw: can be used for straight cuts. Be sure to use a 7-1/4" foam blade, such as Bullet Tools Centerfire or equal, or a non-ferrous/plastic blade, such as Diablo D0756N or equal. Utilize a straight edge to guide the circular saw to ensure the cut edge remains straight. Constant feed rate is critical to limit panel melting on the cut edge.

- When using the circular saw, make sure the blade comes to a complete stop before backing the saw out of the cut.

2.7.2 Make sure panel is supported on a clean surface when making cuts to minimize the risk of blemishes or melting on the cut face.

2.7.3 The same blade should not be used when cutting panels that have different colors in order to minimize the risk of transferring colored fibers between panels.

2.7.3.1 If you only have one cutting blade, mineral spirits (or other similar solvents) can be used to clean the cutting blade with steel wool.

2.7.4 Keep the blade clean and sharp to insure optimal cuts.

2.7.5 Field cut panels may not have an unsupported overhang over 12". A support includes a factory cut hole or a slot in the bottom of the panel. Cuts can be no closer than 1/2" to the nearest slot or a factory cut hole.

NOTE: If a panel is cut down in size, it will need at least two connection points in the Open Cell design.

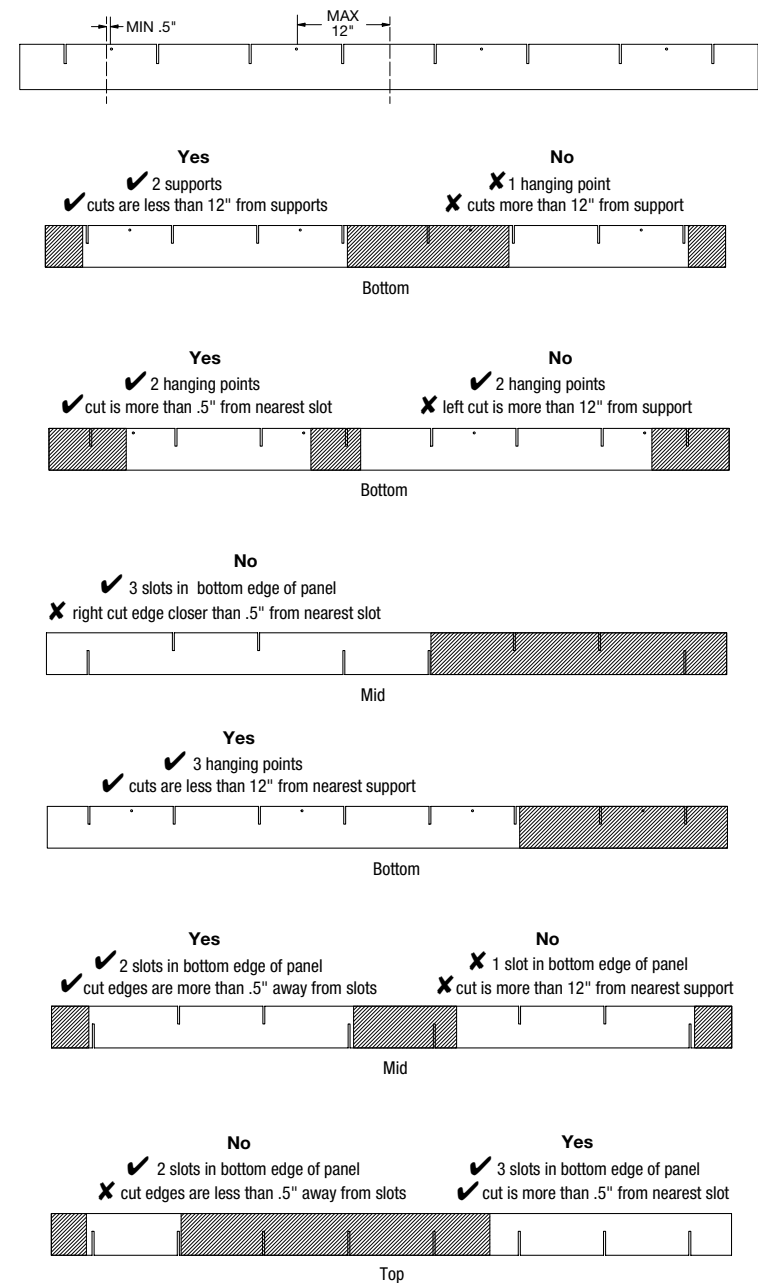

2.8 FeltWorks Open Cell Panel Layout

2.8.1 Minimum spacing between the panels is 12" O.C. due to the preset slots in the Open Cell panels. Custom shaped and sized panels can be ordered through the ASQuote@armstrongceilings.com.

2.8.2 Wall-to-Wall Installations

See section 4.4 for information on how to create a continuous installation across a large, open space.

2.8.3 Discontinuous Spacing

If separate open cell kits are being installed next to each other but are not connected, it is recommended to have 6" of space in between the two systems.

2.9 Product Classification

FeltWorks Open Cell panels are classified as an "architectural element", where no bracing is needed when installed using the aircraft cables. This means the system:

- Must be able to swing 360 degrees.
- Must not come in contact with essential components in the ceiling.
- The maximum swing that can be expected is 18" when aircraft cables are used.

3. PANEL DESIGN

3.1 Panel Types

There are three types of panels in the FeltWorks Open Cell system: the Bottom panel, the Middle (Mid) panel, and the Top panel:

- **Bottom panel:** Bottom panels have factory-cut holes in the top of the panels to accept the fork grippers from the Hanging Kit (item 6655). They also have slots in the top of the panels to accept the Mid panels. They are the only panels that are connected to the Hanging Kit (*Fig 1*).
- **Middle panel:** Mid panels have slots in the bottom of the panels to accept the Bottom panels, and slots in the top of the panels to accept the Top panels (*Figs 2 and 3*).
- **Top panel:** Top panels have slots in the bottom of the panels to accept the Mid panels (*Fig 4*).

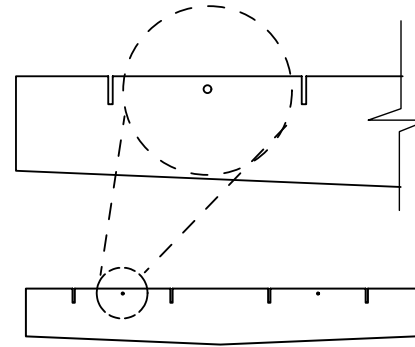

(Fig 1)



(Fig 2)

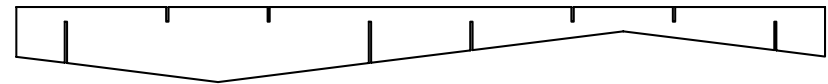

(Fig 3)



(Fig 4)

3.2 Panel Numbering System

Each panel has a two digit identification number printed in line with the furthest most left factory-cut slot of the panel (*Fig 5*). A letter "B" indicates it is a Bottom panel; a letter "M" indicates it is a Middle panel; and a letter "T" indicates it is a Top panel. The numbers will start at one and work their way up in increments of one. Use this numbering system in conjunction with your layout plan to determine the correct orientation of your panels in your overall design.

4. SYSTEM INSTALLATION

The requirements listed here represent the manufacturer's minimum acceptable installation recommendations, and may be subject to additional requirements established by the local authority having jurisdiction.

4.1 Hanging Kit (Item 6655)

FeltWorks Open Cell panels are suspended using aircraft cables and quick release fork gripper adjusters. Item 6655 Hanging Kit includes: (4) 96" long cables with stops, (4) fork gripper adjusters, and (4) gripper structure anchors (*Fig 6*).

4.2 Hanging Kit Installation

- Determine the location of the Open Cell module per the Reflected Ceiling Plan (RCP). Each 8' Bottom panel has four hanging points. Each 4' Bottom panel has two hanging points. Regardless of the Bottom panel size, hanging points are located 12" from the end of the panel and 24" O.C. across the length of the Bottom panel at the factory-finished holes (*Fig 7*).
- Refer to the RCP for the hanging point layout (*Fig 8*).
- Once the attachment points have been plotted, fasten the gripper structure anchor to the structure. Use fasteners (by others) that are compatible with the structure.
- Thread the aircraft cable through the hole on the gripper structure cap.
- Thread the gripper structure cap into the gripper structure anchor.
- Thread the aircraft cable through the fork gripper and raise the fork gripper to the finished height of the entire system. The Mid and Top panels will need to travel above the Bottom panels during installation. In situations where there are obstructions above the finished height that will interfere with the installation of the Mid and Top panels, install the system below the intended finished height by 3" to 4". We recommend not installing the entire system lower than 6" below the intended finished height due to the movement and misalignment caused to the panels as the finished system is raised.

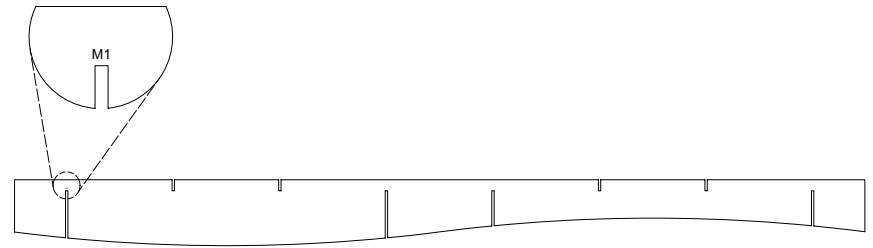

(Fig 5)

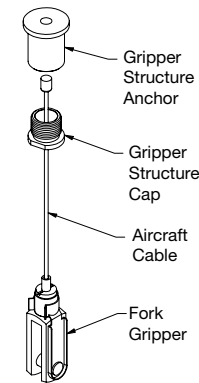

(Fig 6)

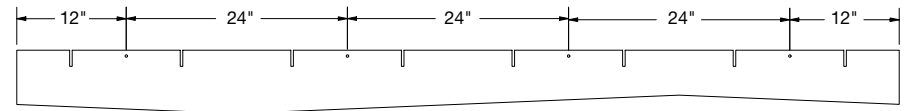

(Fig 7)

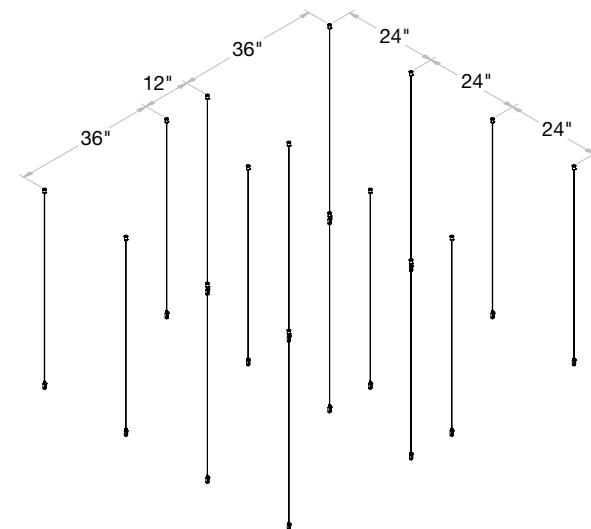

(Fig 8)

4.3 Panel Installation

IMPORTANT NOTE: Leave the panels in the box until the individual panel is ready for installation. If the panels are removed from the box, make sure they are placed on a clean, level surface that supports the entire length of the panel. This helps minimize any soiling and bowing/creasing.

- Make sure to have a copy of your layout plan with you to determine panel location in the design. Refer to the numbers printed on the panels (*Fig 9*).
- Attach the fork gripper to the FeltWorks Open Cell Bottom panel (*Fig 10*) by removing the attachment pin from the fork. Install the fork over the Bottom panel to align with the through holes. Slip the attachment pin through the fork and hole in the Bottom panel and secure the pin to the top of the fork gripper. Repeat until all Bottom panels are installed.
- You should now have rows of Bottom panels hanging by the Hanging Kits (*Fig 11*).
- Install the Mid panels perpendicular to the Bottom panels. Hold the Mid panels above the Bottom panels and line up the factory-cut slots where they intersect on both panels. Slide the Mid panels down into the slots on the Bottom panel until the tops of both panels are aligned (*Fig 12*). The Bottom panels act as the suspension system for the Mid and Top panels.

NOTE: Do not force the panels together, as it can cause undesirable creasing.

- Once all of your Mid panels are installed, slide the Top panels above the Mid panels so they are parallel to the installed Bottom panels and perpendicular to the installed Mid panels. Repeat the same installation method as when you installed the Mid panels (*Fig 13*). When all panels are installed, you should have a flat top with 12" x 12" cells and 90 degree intersections (*Fig 14*).
- If needed, level the system to the finished height by raising the fork grippers, and trim the aircraft cable at the desired length.

IMPORTANT DESIGN CONSIDERATION: Do not allow any portion of the aircraft cable to drop below the bottom of a panel to avoid seeing the cable once installation is complete.

- If needed, to release the cable and lower the panels, take all weight off of the fork gripper, push the release mechanism, and simply slide the cable out as needed.

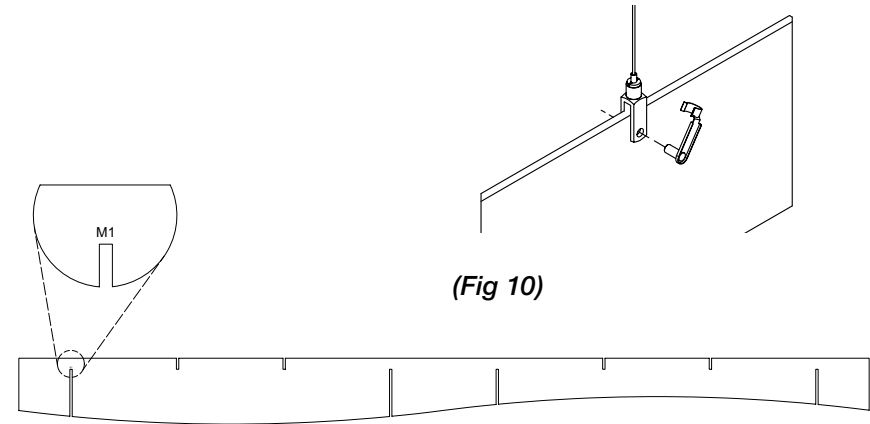

(Fig 9)

(Fig 10)

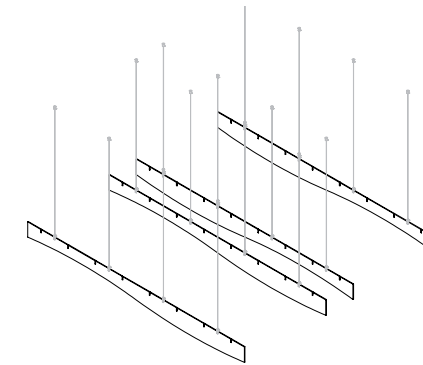

(Fig 11)

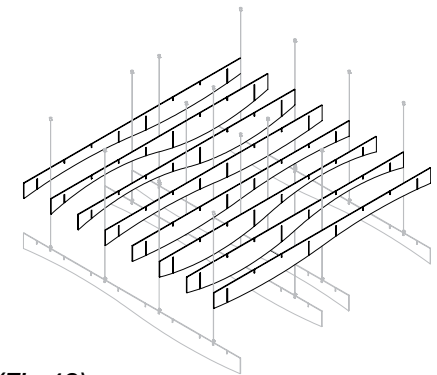

(Fig 12)

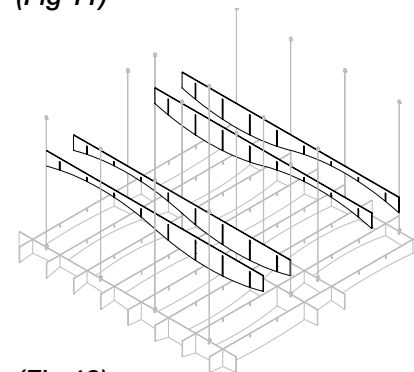

(Fig 13)

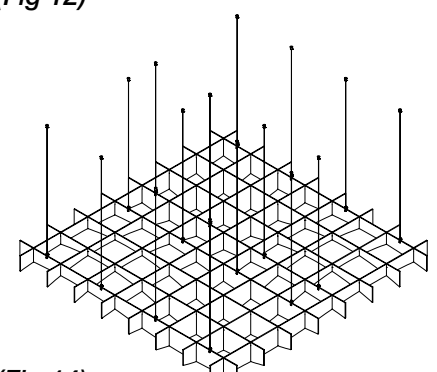

(Fig 14)

4.4 Wall-to-Wall Installations

4.4.1 General

A combination of S8 kits and either S4, R4, or R8 kits will need to be used to create a continuous installation over a large, open space.

Hanging points will be spaced at 24" O.C. in the direction of your Bottom & Top panels. They will be spaced in a pattern of 36" and 12" in the direction of the Mid panels (*Fig 15*).

It is recommended to have at least 2" of space in between the edge of the FeltWorks Open Cell system and the neighboring wall.

Each type of panel within an installation has a corresponding identification number, located by the furthest left slot (*Fig 16*).

4.4.2 Laying Out the Panels

- Start at one end of the installation and alternate between 8' and 4' panels every other row. The pattern of panels in this direction is Bottom, Top, Top, and Bottom (*Fig 20*).
- Next, fill in the rest of the field with 8' panels, still following the pattern of Bottom, Top, Top, and Bottom (*Fig 21*).
- Fill in 4' panels at the other end of the installation (*Fig 22*).
- Next, start at the top of the installation and lay out the Mid panels perpendicular to the Tops and Bottoms alternating 8' and 4' panels every other row. It should be only Mid panels in this direction (*Fig 23*).
- Fill in the rest of the field with 8' Mid panels (*Fig 24*).
- To finish, place 4' panels to fill in the end of the installation (*Fig 25*).

4.4.3 Rectangular Kits

In Rectangular installations, Bottom panels B1 & B2 will always be installed in the same row; Mid panels M1 & M2 will always be in the same row; and Top panels T1 & T2 will be in the same row (*Fig 26*).

NOTE: See pages 10-11 for Wall-to-Wall Installation and Panel Orientation drawings. (*Figs 20-26*)

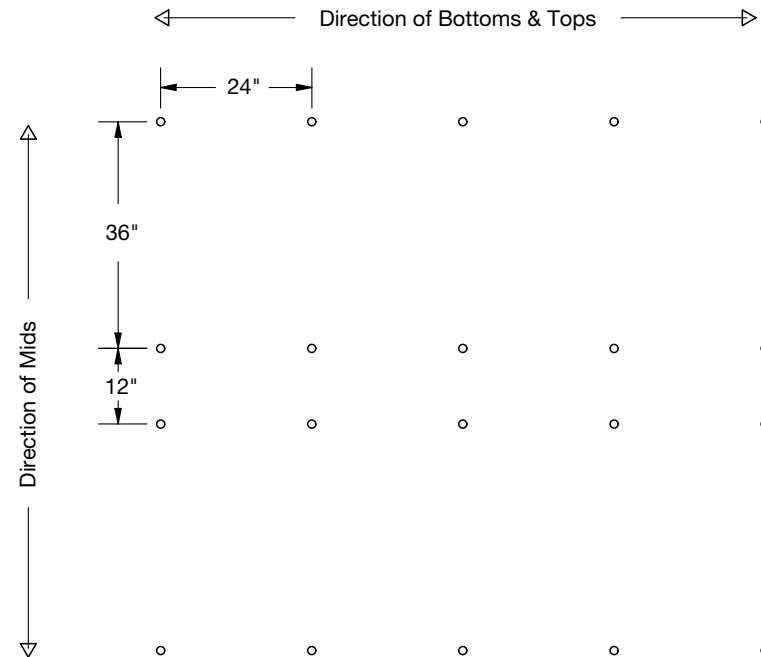

(Fig 15)

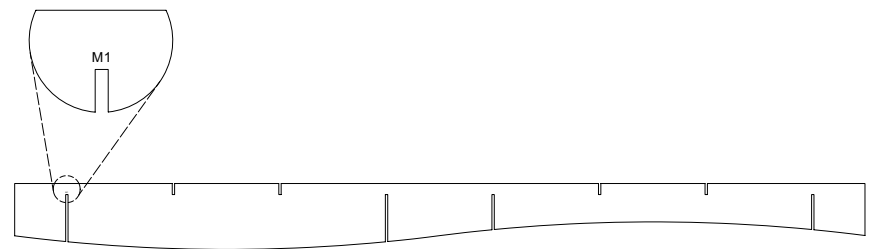

(Fig 16)

4.4.4 Peaks & Valleys and Ebbs & Flows Kits

In both Peaks & Valleys and Ebbs & Flows installations, Bottom panels B1, B2, & B3 will always be installed in the same row as one another. They will never be in the same row as a different type of panel. Similarly, panels M1, M3, & M5 will always be in the same row; Mid panels M2, M4 & M6 will always be in the same row; and Top panels T1, T2, & T3 will be in the same row (*Figs 17 and 27*).

NOTE: See page 11 for (*Fig 27*) panel drawings

It is important to keep in mind the up and down pattern when laying out the panels with Ebbs & Flows and Peaks & Valleys installations. Panels with an asterisk next to them need to be flipped 180 degrees during installation to make sure the up and down part of the panel are in the correct orientation (*Figs 18 and 19*).

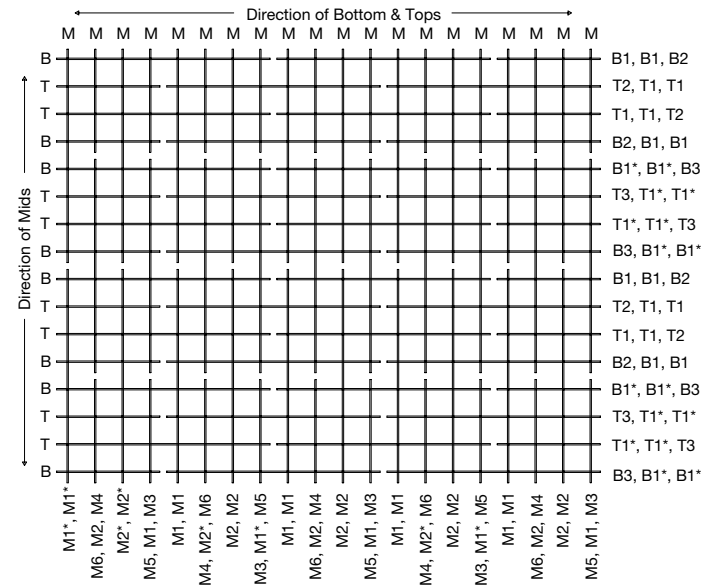

(Fig 17)

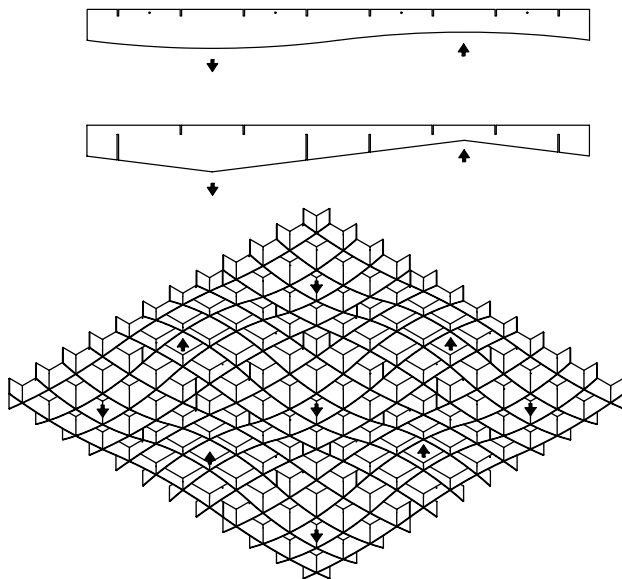

(Fig 18)

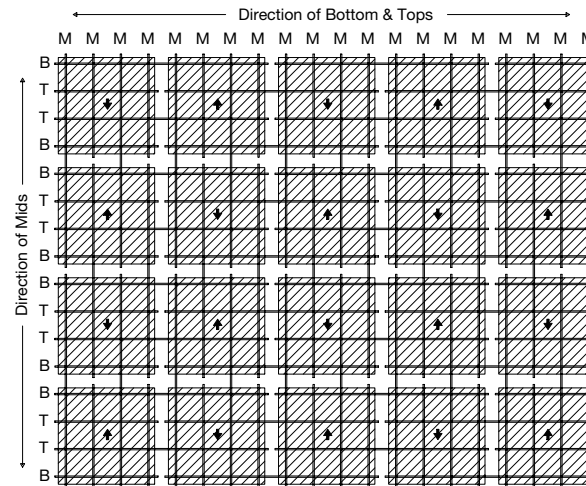

(Fig 19)

5. SPECIAL INSTALLATION CONSIDERATIONS

5.1 Acoustical Grid Installations

The FeltWorks Open Cell system can be suspended from the Hanging Kit (Item 6655) and attached to acoustical grid as long as the following requirements are met:

- Screws can only be attached to Heavy-Duty mains and Heavy-Duty Equivalent cross tees (i.e. items 7301, XL7341, XL8320).
- Screws must go through a flange on either side of the web and cannot go directly up the center of the grid (in-between the web).

Screw requirements:

- Pan, wafer, or truss head: The screw is fully seated when the head is flush with the work surface. A 'bugle' head (for attaching gypsum board or wood sheathing) is not appropriate for this application.
- Threads: Fine thread, Type S. This is the appropriate thread type for light-gauge metal.
- Length: Long enough to ensure fastener penetrates beyond the metal with 3 full thread pitches.
- Diameter: #7 minimum
- Added load from the panels must not cause the overall load to exceed the carrying capacity of the grid member it is attached to.
- This method is only allowed for Prelude grid.
- This has not been evaluated for Seismic Design Categories C, D, E, or F. Additional testing and evaluation may be required.

5.2 Sloped Installations

FeltWorks Open Cell panels are intended for the bottom edge to be on a horizontal plane and are not recommended for a sloped installation. This applies to all Seismic Design Categories.

5.3 Product Classification

FeltWorks Open Cell panels are classified as an "architectural element" (no bracing is needed) when installed using aircraft cables. The system:

- Must be able to swing 360 degrees.
- Must not come in contact with essential components in the ceiling.
- The maximum swing that can be expected is 18" when aircraft cables are used.

5.4 MEP Integration

Mechanical fixtures such as lights, speakers, and sprinklers should be installed into the plenum area before installing the FeltWorks Open Cell panels. FeltWorks Open Cell panels should not be installed near sources of heat greater than 158 degrees F. Fixtures can be installed flush with the top of the panels or flush with the bottom of the panels (refer to

section 2.2 for sprinkler considerations). Fixture weight or housing must not be supported by the panels. Any integrated MEP fixtures must be independently supported.

5.5 Swimming Pool Installations

FeltWorks Open Cell panels cannot be installed in swimming pool applications.

5.6 Exterior Installations

FeltWorks Open Cell panels cannot be installed in exterior applications.

6. SEISMIC INSTALLATIONS

The following are modifications to installations that are Seismic Category C, D, E or F.

Please refer to our "*Seismic Design: What You Need to Know*" brochure for more details on seismic installations.

6.1 Aircraft Cable Installation

This system has been tested and approved for installation in all IBC Seismic Design Categories. ASCE 7 provides an exception to the restraint requirement for architectural components stated in section 13.5.1, provided that:

- The connection to the structure shall allow a 360 degree range of motion in the horizontal plane.
- The component may not cause damage to an essential building element

The International Building Code allows architectural components to swing freely as long as they will not be damaged or cause damage. Cable lengths less than 20" will generate the greatest amount of pendulum reaction during a seismic event and should, therefore, be avoided.

When it is not practical to use cables greater than 20" long, allow lateral clearance around the architectural component equal to, or greater than, the length of the cable. Architectural components suspended from cables greater than 20" long will swing no more than 8". Restraint of architectural elements has proven to be ineffective and is not recommended.

FeltWorks Open Cell panels must be spaced a minimum of 12" from surrounding surfaces to avoid contact during a seismic event.

6.2 No additional requirements or modifications are required for OSHPD/DSA installations.

6.3 Seismic installations of FeltWorks Open Cell are to be handled per building code. Please check with your local code official to see if any additional requirements are needed.

WALL-TO-WALL INSTALLATION

Start at one end of your installation and alternate between 8ft and 4ft panels every other row. The pattern of panels in this direction is Bottom, Top, Top, Bottom.

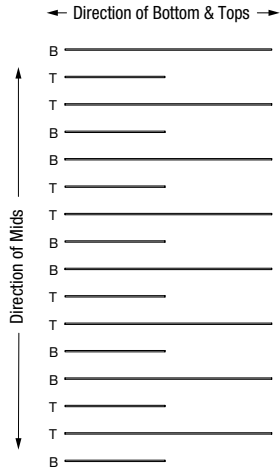

(Fig 20)

Next, fill in the rest of your field with 8ft panels, still following the pattern of Bottom, Top, Top, Bottom.

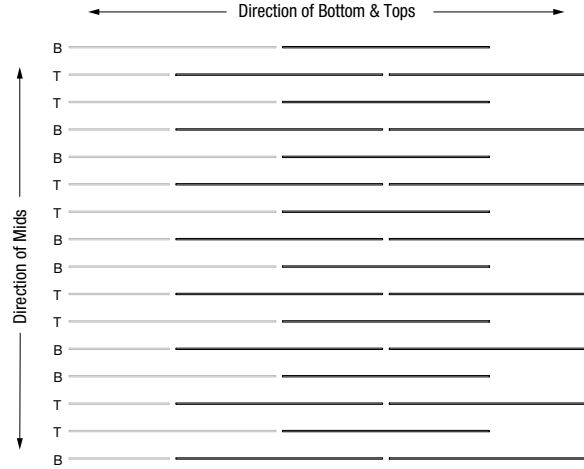

(Fig 21)

Fill in 4ft panels at the other end of the installation. Still keep in mind your pattern of Bottom, Top, Top, Bottom.

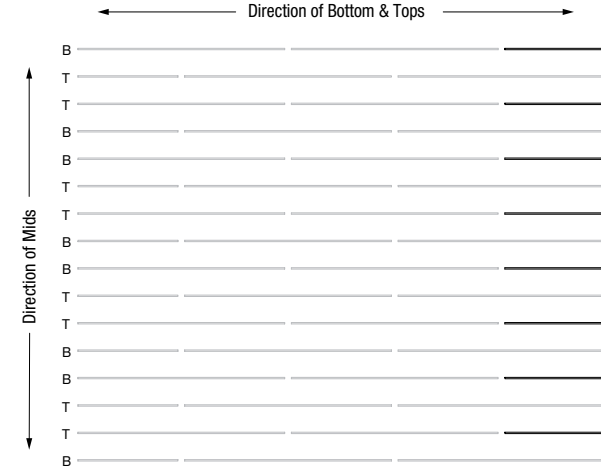

(Fig 22)

Next, start at the top of your installation and lay out your Mids perpendicular to your Tops and Bottoms alternating 8ft and 4ft panels every other row. It should be only Mids in this direction.

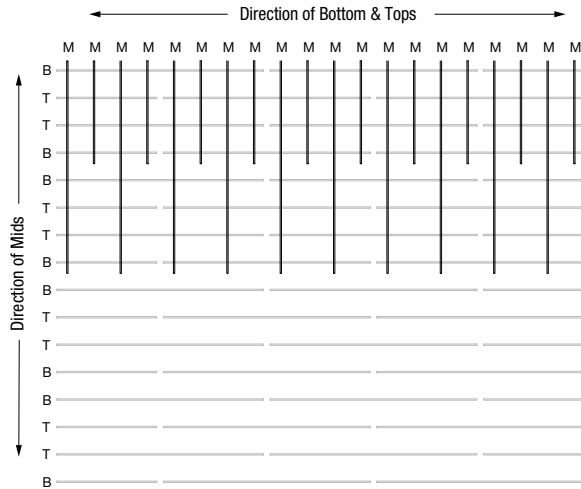

(Fig 23)

Fill in the rest of your field with 8ft Mids.

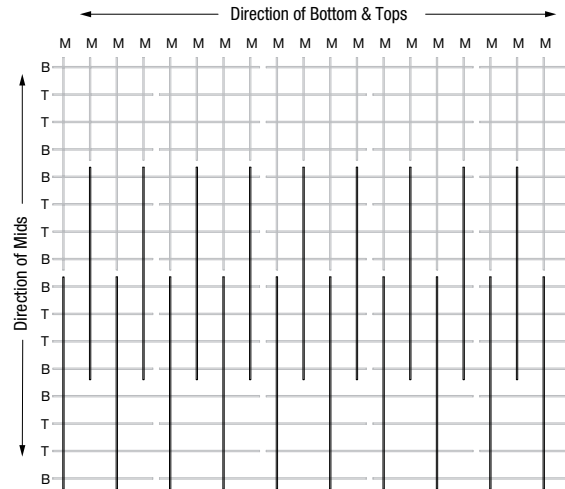

(Fig 24)

Lastly, place 4ft panels to fill in the end of your installation.

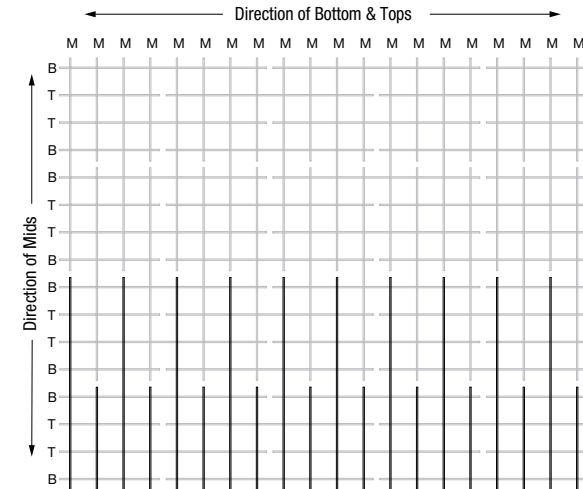

(Fig 25)

PANEL ORIENTATIONS

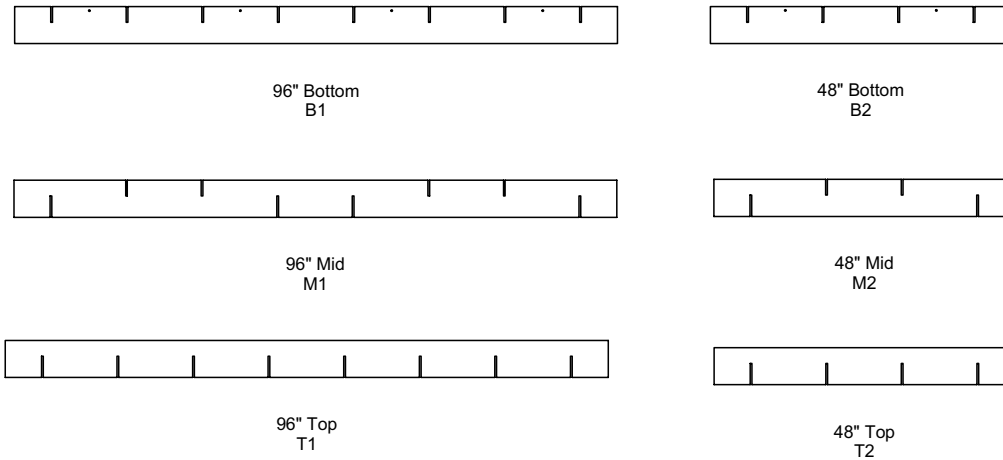

(Fig 26)

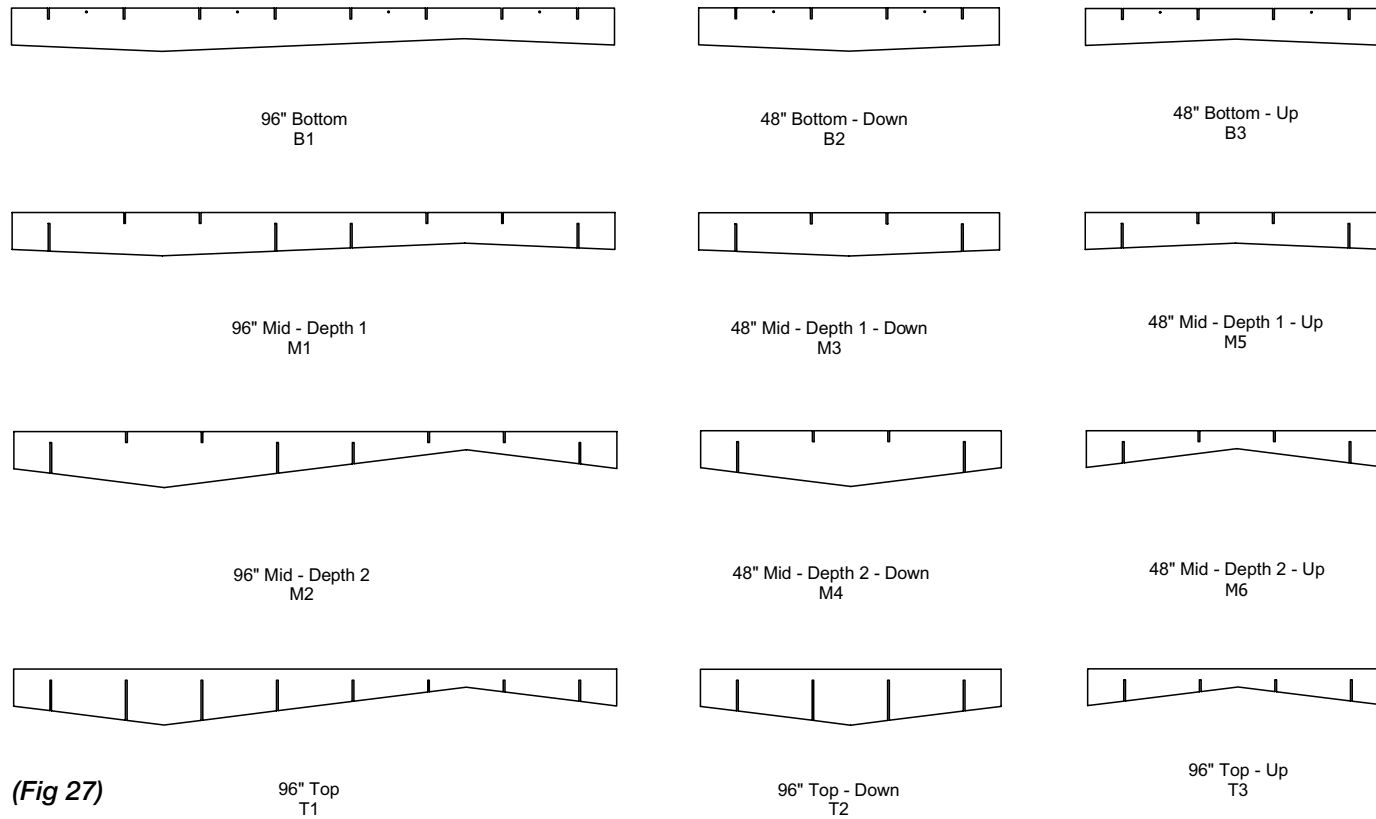

(Fig 27)

MORE INFORMATION

For more information, or for an Armstrong Ceilings representative, call 1 877 276 7876.

For complete technical information, detail drawings, CAD design assistance, installation information, and many other technical services, call TechLine customer support at 1 877 276 7876 or FAX 1 800 572 TECH.

Inspiring Great Spaces® is a registered trademark of AFI Licensing LLC; All other trademarks used herein are the property of AWI Licensing LLC and/or its affiliates.

© 2020 AWI Licensing Company Printed in the United States of America

