

# FORMATIONS™ Clouds with AXIOM® Knife Edge/ Knife Edge Vector® Trim and Suspension System

## Assembly and Installation Instructions

### 1. DESCRIPTION

**1.1** Formations™ Clouds is a perimeter trim system designed to create ready-to-assemble full panel installations for “ceiling clouds” sized from 6' x 6' up to 14' x 14'. Formations are designed to work with Armstrong FILAMENTS™, INFUSIONS®, OPTIMA™, ULTIMA™, and METALWORKS™ products in Vector™, flat and Tegular edges for 15/16" grid.

#### 1.1.2 Included in the Kit are:

- Axiom Trim, with factory cut end details to form a cloud to the required size.
- Suspension system components cut-to-length to provide for full-size installation of 24 x 24 panels.
- Aircraft Cable, cut to 10' length, in the amount required for the installation
- Support Hanger carrying channel, cut-to-length to accommodate installation of the aircraft cable) 24" from the vertical face of the Axiom trim.
- Axiom splices to join together sections of Axiom
- Axiom Connector Clips to join suspension system components to the Axiom Trim
- Axiom component diagram to properly position perimeter trim sections

**NOTE:** Pop-rivets, screws and hardware required for attachment to structure are not included. Ceiling panels are ordered separately.

Kits contain all of the components required to construct and hang a complete cloud except for the ceiling panels, the screws or pop-rivets needed to attach the clips to the grid members and the hardware needed for attachment to structure.

**1.1.3** Most building codes require non-structural building components to be restrained. Armstrong also recommends restraint in accordance with local building code requirements. Please consult with the building code professional having jurisdiction over the project to determine appropriate restraint requirements for this installation. Restraints are not included in this kit.

**1.1.4** Formations, as with other architectural features located in the ceiling plane, may obstruct or skew the existing or planned fire sprinkler water distribution pattern, or possibly delay the activation of the fire sprinkler or fire detection system. Designers and installers are advised to consult a fire protection engineer, NFPA 13, and their local codes for guidance on the proper installation techniques where fire detection or suppression systems are present.

**CAUTION:** Ceiling panels used in Formations Clouds must be limited to no more than 1.25 lb/sf. Use of panels weighing more than this stated limit could result in failure of suspension system components.

### 2. INSTALLATION

**IMPORTANT NOTE:** Use Axiom Knife Edge-Vector when installing Ultima, Optima or MetalWorks Vector panels. Use Axiom Knife Edge when installing flat or Tegular panels.



Vector Panel

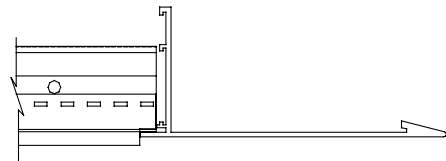

Tegular Panel



Square Edge Lay-In Panel

### 3. PRE-ASSEMBLY

**3.1** Study the layout drawing for the cloud and verify that kit contents are complete. Call 800-840-8521 to request replacements for missing components.

**3.2** Review the location of the Support Hanger carrying channels. They will be located 2' from the longest side of the cloud and then 4' on center (note that in some instances this pattern will result in two Support Hanger carrying channels being positioned 2' from one another at the center of the cloud).

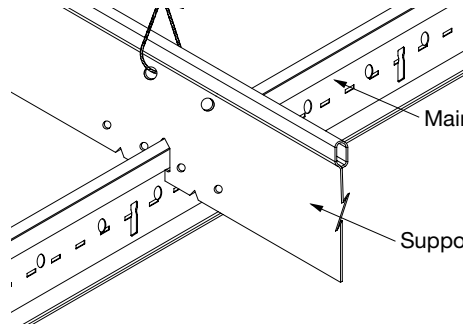

### 4. ATTACH HANGING CABLES TO STRUCTURE

**4.1** Hanging cables (item AC1210) are located along the length of the StrongBack carrying channel starting 1' from the end (2' from the edges of the cloud) and then 4' on centers (note that in some instances this pattern will result in two hanging cables being positioned 2' from one another at the center of the cloud).

**4.2** Hardware for the attachment of the cable to the building structure is not provided. Cables are fitted with a loop at one end that is to be cinched to mounting hardware appropriate for the surface to which it is attached. Select hardware that will be capable of supporting a minimum of 200 pounds.

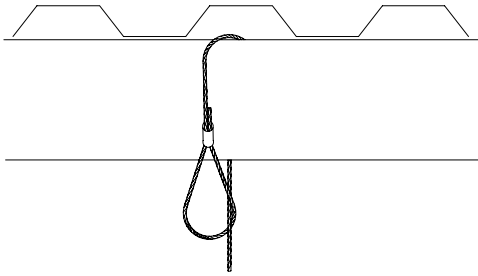

**6.2** Attach Axiom T-Bar Connector Clips (item AXTBC) to each end of each main by positioning as shown in the drawing. The top of the clip should touch the bottom of the bulb of the grid and the end of the main should contact the thumbnail stop on the clip. Secure each clip with two pop-rivets or #8 sheet metal screws (note that pop-rivets are preferred over screws because they will not interfere with the placement of the ceiling panels).

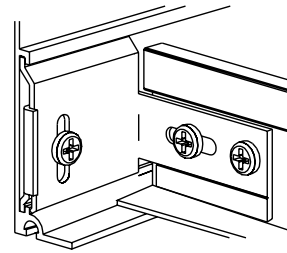

### 5. HANG SUPPORT HANGER

**5.1** Attach the Axiom Support Hanger channels (item SHC4, 6, 8, 10, 12) to hanging cables using the adjustable "Quick Loop" connectors (item ACHC) provided with the kit. Insert the cable through one end of the connector and then through the appropriate hanger wire hole on the support channel. Slide the cable back through the "Quick Loop" connector and adjust to the correct elevation. Follow the instructions provided with the connectors if it becomes necessary to release the cable from the connector.

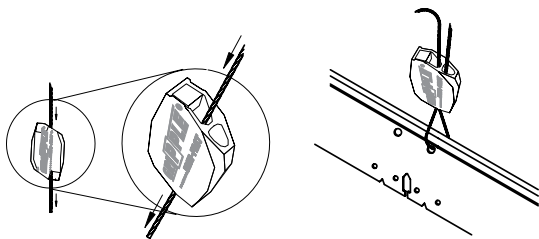

### 7. INSTALL TEES

**7.1** Install 2' cross tees between mains. After all tees have been installed, slide the Support Hanger channel along the mains so that it rests against the cross tees. Screw the support channel to the tees by inserting a #8 x 9/16" sharp point sheet metal screw into the holes on each side of the main as shown in the drawing below.

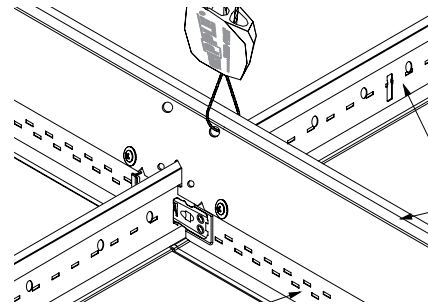

**7.2** Bend the tabs at the ends of the Support Hanger channel as shown so that they will fit under the bottom of the bulb of the tees and secure with a #8 x 9/16" screw.

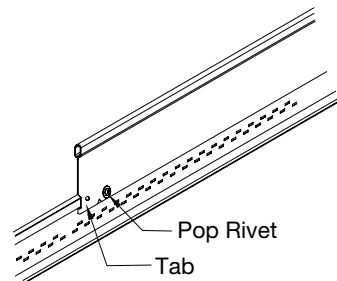

### 6. INSTALL MAINS

**6.1** Install mains into the appropriate notches on the Support Hanger channels. The first main will be 1' from the end of the channel and the remainder will be placed at 2' centers. Slide the main through the notches or bend the tab on one side of the notch out of the way so that the main can be installed from below. Bend the tab back into position under the bulb of the main.

**7.3** Cut away the end detail on the cross tees that will engage the Axiom trim. Attach an Axiom T-Bar Connector Clip to the end of each tee as shown.

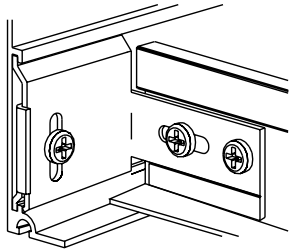

**7.3.1** Align the clip such that the lower two holes in the three hole line match up with the holes in the end of the tee. Insert two fasteners through the tee and into the clip.

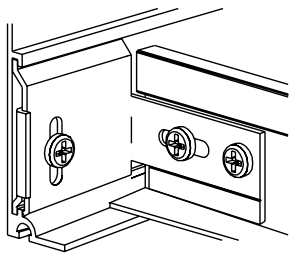

**8. INSTALL AXIOM TRIM**

**8.1** Use the assembly drawing provided to arrange the Axiom trim sections and corners in the proper sequence. Mark the locations for the grid members on the inside of the trim as follows: The edge of the first tee or main closest to the corner should be located 23-1/16" from the edge of the Axiom flange at the corner. Remaining parts will be located 24" on center.

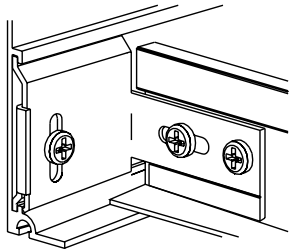

**8.2** Connect sections of Axiom trim and corners with splice and alignment plates as required. The supplied assembly drawing will show the correct quantity and location for the plates.

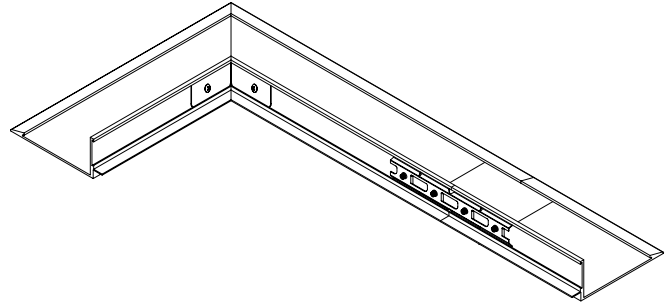

**8.3.1 DO NOT OVERTIGHTEN SET SCREWS.** Excessive torque will result in deformation of the trim that will show on the finished surface.

**9. INSTALL RESTRAINT/SEISMIC BRACING**

**9.1** Restraint for Clouds installed on projects where anticipated seismic activity will be light (IBC seismic design categories A & B) can be accomplished by installing a pair of crossed cables 2' in from each edge of the assembly. These cables should attach to the support channels and be sloped no more than 45° from horizontal.

**9.2** In areas where anticipated seismic activity will be moderate to severe the crossed cables should be replaced with a bracing system more appropriate for the forces that will be encountered.

**9.2.1** Testing conducted at the Structural Engineering Earthquake Simulation Laboratory, located at the State University of New York - Buffalo campus produced satisfactory results with rigid bracing fabricated from 1/2" EMT conduit.

**9.2.2** The tested bracing system consisted of a vertical member extending from the support channel to the structure above near each corner of the cloud. These members were positioned at the main beam/support channel intersections closest to the corners of the assembly. Two additional members were fastened to the bottom of the vertical and extended to the structure at an angle not exceeding 45° from horizontal. These members were parallel to the sides of the cloud.

**9.2.3** Restraint/bracing systems should be approved by the project design team and reviewed with local building department.

**10. INSTALL CEILING PANELS**

**10.1 IMPORTANT NOTE:** Ultima and Optima Vector panels should be installed with Seismic Hold Down Clips (item 442) in all projects designated as Seismic Design Category D, E, or F. Refer to installation instruction (CS-3426 0602) for guidance on the correct application of these clips.

**10.2** Clean and align Axiom components and install ceiling panels to complete the assembly.

## **MORE INFORMATION**

For more information, or for an Armstrong representative, call 1 877 ARMSTRONG.

For complete technical information, detail drawings, CAD design assistance, installation information, and many other technical services, call TechLine<sup>SM</sup> customer support at 1 877 ARMSTRONG or FAX 1 800 572 TECH.

For the latest product selection and specification data, visit [armstrong.com/ceilings](http://armstrong.com/ceilings).

All trademarks used herein are the property of AWI Licensing Company and/or its affiliates  
© 2016 AWI Licensing Company • Printed in the United States of America

BPLA-297183-116

