

GROIN VAULT Square & Rectangle Room Layout

Assembly and Installation Instructions

GROIN VAULT

A Groin Vault is formed by intersecting two barrel vaults, or curved ceilings. A groin is the curved intersection of the two vaults. Vault intersections can be an inside or outside groin, both use the same process to create a template.

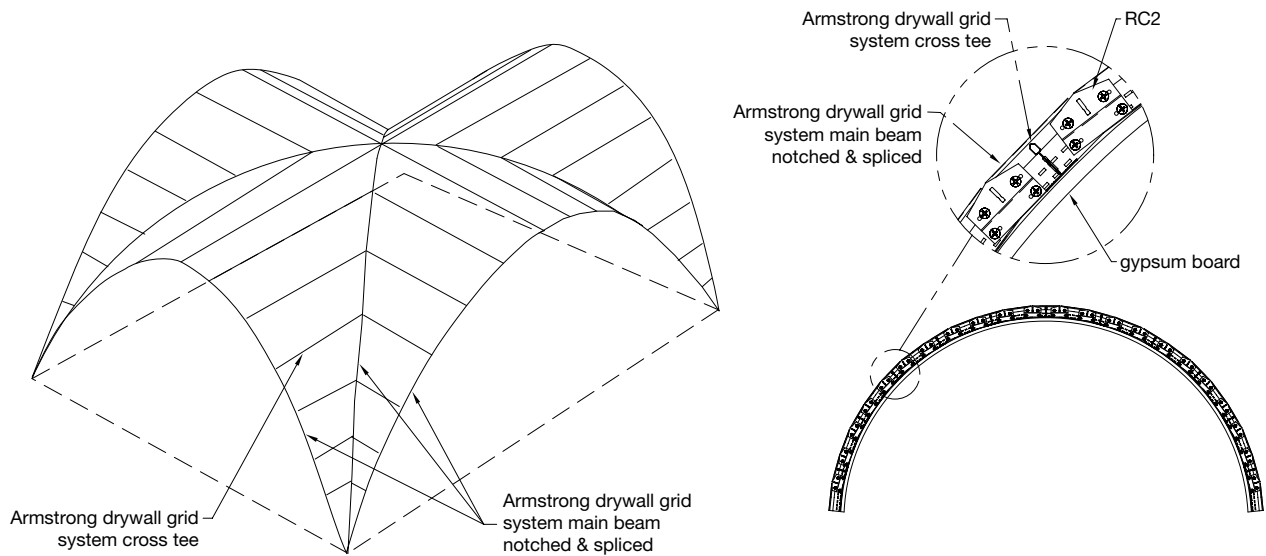

SQUARE ROOM LAYOUT

This is the simplest type of groin ceiling to layout and install. The four primary vaults are the same, and the groin will be an elliptical vault running diagonally corner-to-corner. This will require two templates – one for the primary vault and one for the groin. Groin template must be to scale, full size, best done on the floor directly below the vaults to use as an installation reference.

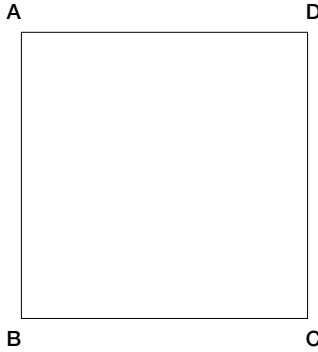

Step 1: Lay out the square A, B, C and D to represent the dimensions of the room.

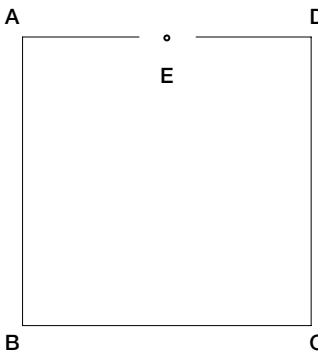

Step 2: Determine the midpoint of line A - D and label E. This is the radius point for the primary vaults.

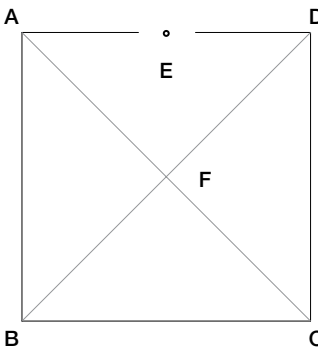

Step 3: Layout diagonal lines A - C and B - D – these are the groin lines. Label the intersection of these lines F.

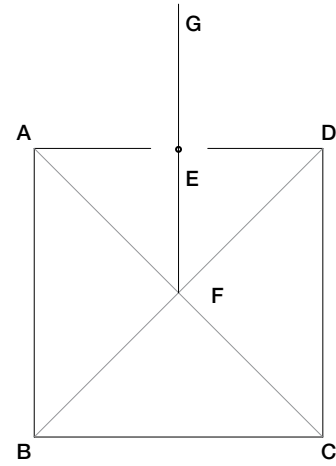

Step 4: Layout line F - G beginning at point F, running through point E, equal in length to side A - B. Point G represents the top of the vault, and line F - G represents the centerline of the vault.

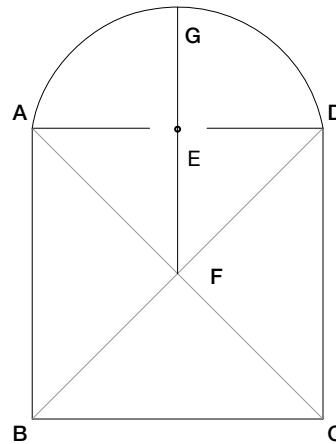

Step 5: Using point E as the center point, and dimension E - A as the radius, form the primary vault from points A to D.

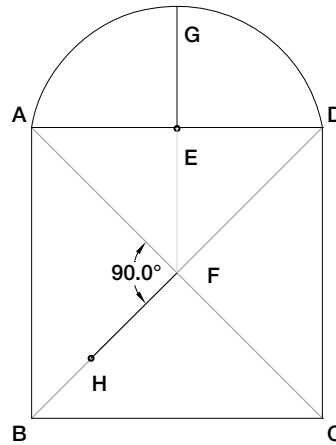

Step 6: Use the rise of the primary vault (E - G) and locate the rise of the groin vault (F - H).

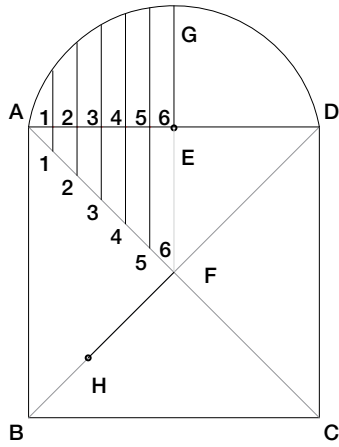

Step 7: Run lines parallel to line F - G at one foot intervals beginning at point E and moving towards point A. Number the points where these lines intersect the diagonal (A - C) beginning at point A.

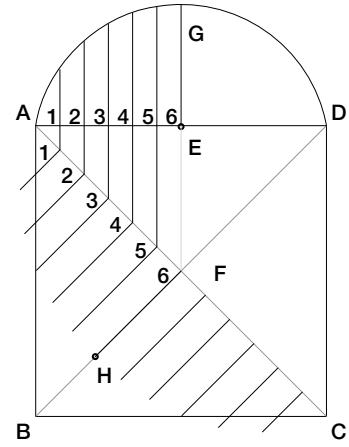

Step 10: Mirror points created in Step 8 along line F - C.

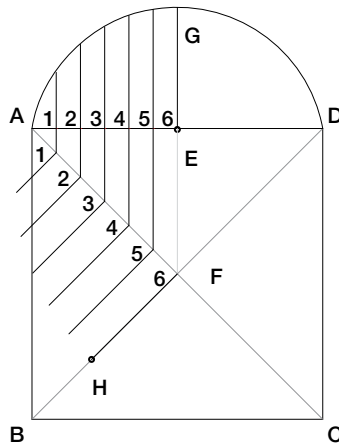

Step 8: Mark and run lines perpendicular to line A - C at each of the points created in Step 7.

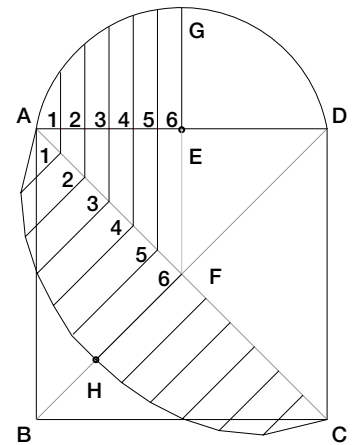

Step 11: Form the groin vault by connecting the points created in Steps 9 and 10.

Step 12: Curves A, G, D and A, H, C can be used to create templates to construct faceted main beams.

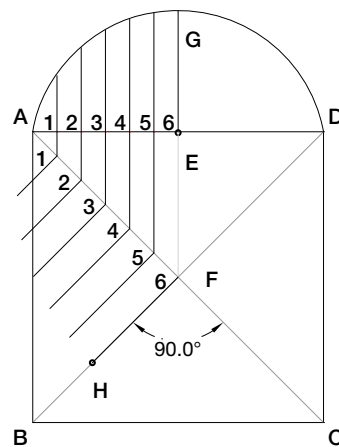

Step 9: Transfer length of each line created in Step 7 to corresponding lines created in Step 8. This will create curve points of the groin vault.

RECTANGULAR ROOM LAYOUT

Layout for rectangular rooms is similar to that for square rooms, except that three templates will be required: the primary vault for the short walls, a true radius vault, the secondary vault for the long walls, this will be an elliptical arch, and the groin vault running diagonally corner to corner. The rise for each vault will be the same dimension.

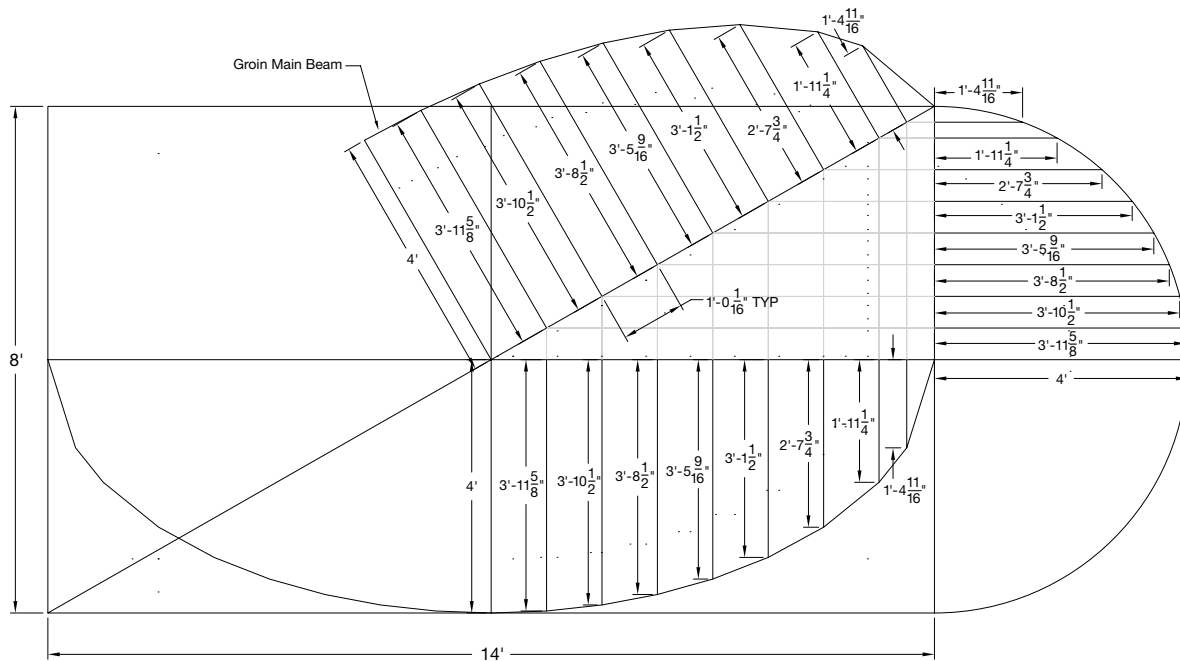
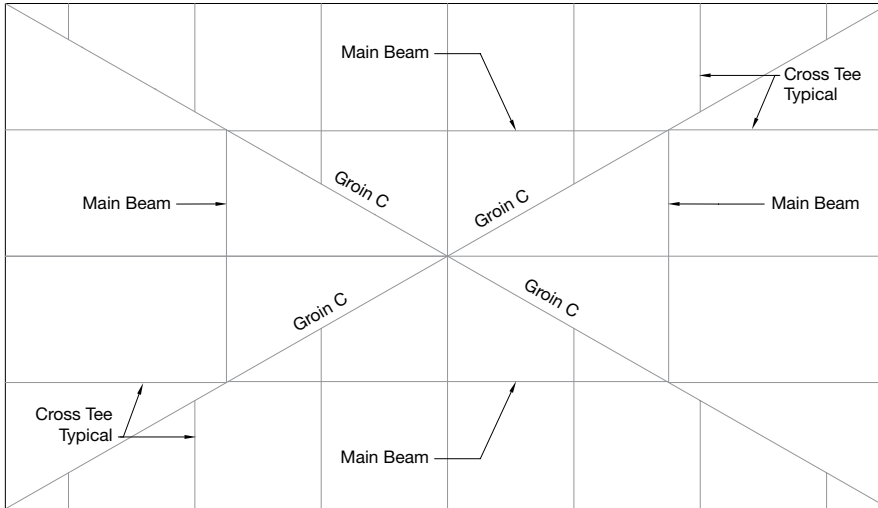

MORE INFORMATION

For more information, or for an Armstrong representative, call 1 877 ARMSTRONG.

For complete technical information, detail drawings, CAD design assistance, installation information, and many other technical services, call TechLineSM at 1 877 ARMSTRONG or FAX 1 800 572 TECH.

For the latest product selection and specification data, visit armstrong.com/ceilings.

U.S. Patents Pending, including US Publication No. 2004/0182022.

All trademarks used herein are the property of AWI Licensing Company and/or its affiliates
© 2015 AWI Licensing Company • Printed in the United States of America

BPLA-297444-315



CEILING & WALL SYSTEMS