

INFUSIONS® Blades – Concepts™ Vertical Elements

Assembly and Installation Instructions

1. GENERAL

1.1 Product Description

Infusions Blades – Concepts are vertical profile accent panels designed to be suspended from the Infusions Blades – Concepts suspension bar. Infusions Blades – Concepts are available in three lengths.

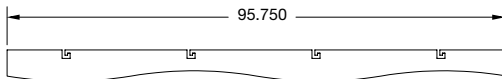
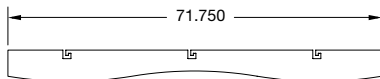
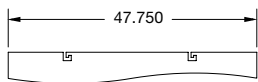

1.2 Storage and Handling

Infusions Blades – Concepts should be stored in a dry interior location and shall remain in the original cartons prior to installation to avoid damage. The cartons should be stored in a flat, horizontal position. Proper care should be taken when handling the blades to avoid damage and soiling.

NOTE: Infusions Blades – Concepts are wrapped with a clear plastic protective film that is to remain on the product until installation occurs.

1.3 Site Conditions

Building areas to receive ceilings shall be free of construction dust and debris.

1.4 Design and Installation Limitations

Infusions Blades – Concepts should always be installed in accordance with all applicable building codes and regulations.

Do not cut holes in or drill through Infusions Blades – Concepts. Doing so may cause the blade to bend in an irregular fashion.

Do not allow blade to get wet.

Infusions Blades – Concepts are susceptible to “wicking.” If the blade is placed in a damp or wet area, water may “wick” up through the blade.

Infusions Blades – Concepts are not approved for exterior application.

Polycarbonate blades can be damaged by exposure to high temperatures. Blade temperature should not be permitted to exceed 100° F. Follow these guidelines for minimum distance from standard light sources:

Lamp Type	Label Wattage	Minimum Distance
Halogen FL XL PAR 30	60	14"
Incandescent Bulb	120	15"
Quartz Halogen Work Light	500	23"

1.5 Fire Performance

Infusions Blades – Concepts may obstruct or skew the existing or planned fire sprinkler water distribution pattern, or possibly delay the activation of the fire sprinkler or fire detection system. Designers and installers are advised to consult a fire protection engineer, NFPA 13, and their local codes for guidance on the proper installation techniques where fire detection or suppression systems are present.

1.6 HVAC Design & Operation

Proper design for both supply air and return air, maintenance of the HVAC filters and building interior space are essential to minimize soiling. Before starting the HVAC system, make sure supply air is properly filtered and the building interior is free of construction dust.

1.7 Plenum

Since blades are installed from below, Infusions Blades – Concepts require minimal clearance above the suspension system. Infusions Blades – Concepts never need to travel into the plenum space during installation or removal.

2. INSTALLATION

2.1 Suspension System

Infusions Blades Concepts are not designed for sloped installations.

Infusions Blades – Concepts install on aluminum suspension bars, which are hung with the Blades Hanging Kit suspension assemblies. Each suspension bar requires one hanging kit which includes four hanging assemblies.

1. Determine the direction of the blades, per the RCP; suspension bars will be installed perpendicular to the length of the blades. The main suspension bars should be installed 11-7/8" OC from the desired starting location of the blade end and continuing 24" OC across the field of the installation, making the last row end 11-7/8" from the end of the run of blades. (Refer to detail below).

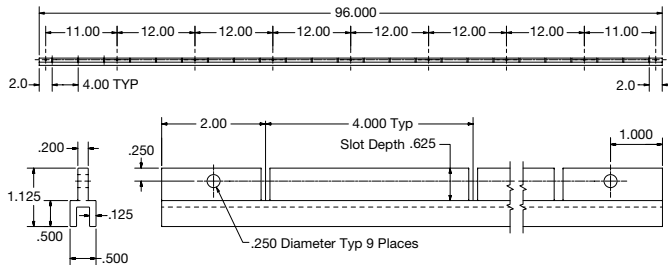

2. Determine the location to hang the first suspension bar.

Blades Hanging Kit – Item #6655 (one kit contains four assemblies; each suspension bar uses one kit with the assemblies located 12" from the end and then at 2' OC across the length of the bar in pre-drilled holes)

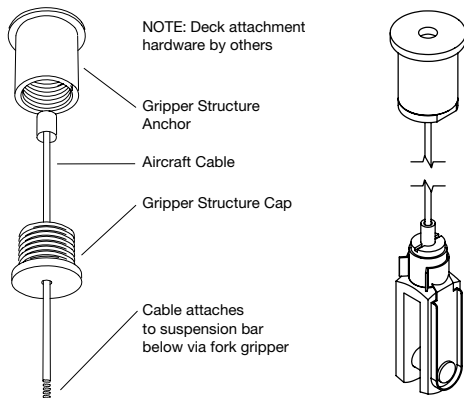

Note: In cases where attachment to structure is not possible at 24" centers, hanging kit assemblies can be spaced at a maximum of 36" OC along the length of the bar and within 12" of each end of the bar. (holes for the Attachment Pin will have to be drilled in the field).

3. Fasten the gripper structure anchor to the structure. Use fasteners (by others) that are compatible with the structure.
4. Thread the aircraft cable through the hole on the gripper anchor cap.
5. Thread the gripper anchor cap onto the gripper structure anchor.

6. Attach the fork gripper to the suspension bar by removing the attachment pin from the fork. Install the fork over the vertical fin of the suspension bar to align with the through holes.

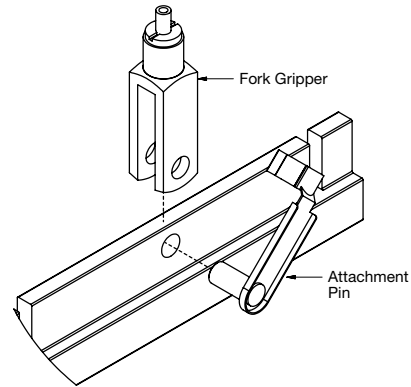

7. Slip the attachment pin through the fork and hole in the suspension system and secure the attachment pin to the top of the fork gripper.

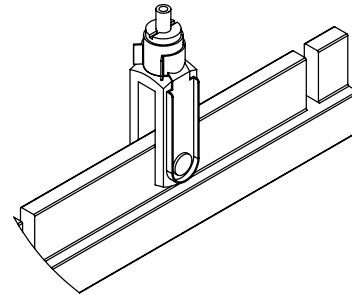

8. Runs of suspension bars can be achieved using the end-to-end connector (item 6651AB).

Slip the connector over the vertical fin of two adjacent suspension bars, and align the holes in the connector with the holes in the suspension bar. Attach them together using the provided fasteners. This can be done on both ends of the 96" suspension bar.

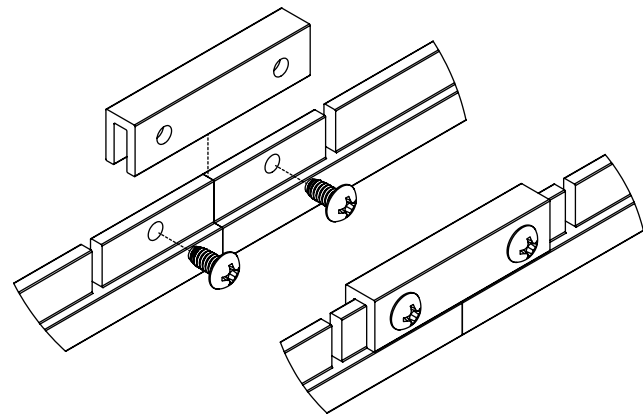

9. At the perimeters of the installation the suspension bars can be cut to length (see below). The suspension bars are extruded aluminum and it is recommended that they are cut with a metal cutting chop saw or battery powered circular saw. When cutting to length, be sure to leave at least 3/8" of material from the last notch to the end of the suspension bar.

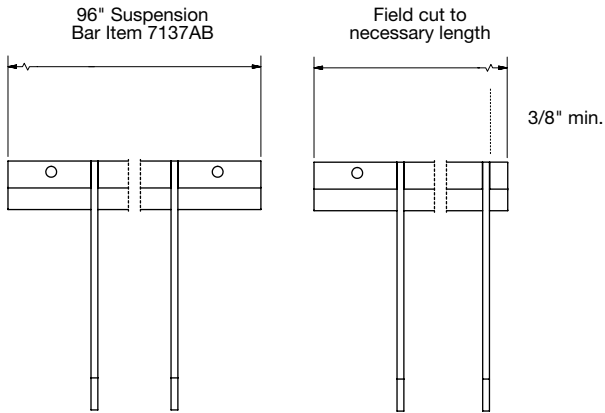

To touch up cut ends of the suspension bar, use a commercially available matte black paint.

2.2 Suspension Layout

Refer to the procedures in section 2.1 to determine suspension bar hanging locations. These will be installed 11-7/8" OC from the desired starting location of the blade end and continue 24" OC across the field of the installation (see below).

Note: The first row of suspension bars must be installed at least 13-7/8" OC from the wall to ensure a minimum of 2" clearance necessary for proper blade installation. Notches to receive the blades are spaced at 4" OC along the length of the suspension bars. See typical RCP view below.

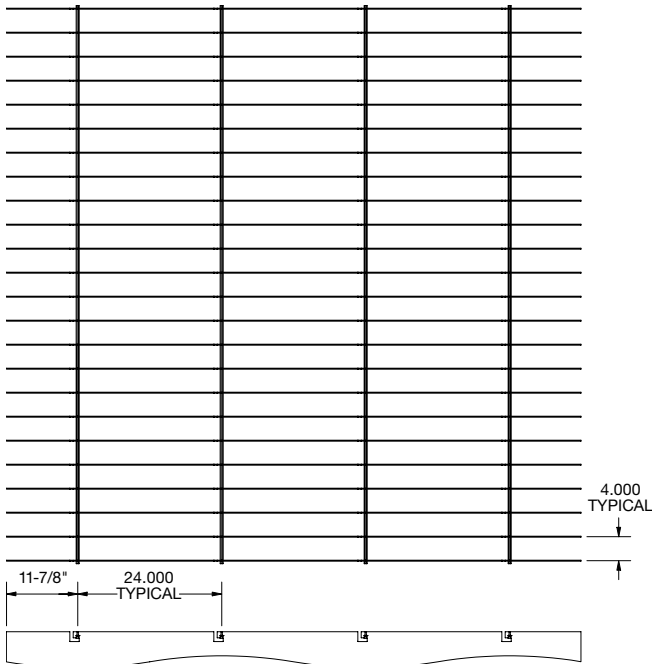

For larger installations using multiple suspension bars to achieve the layout width, end-to-end connectors (item 6651AB) will need to be used to splice the suspension bar together.

3. BLADE INSTALLATION

Infusions® Blades – Concepts™ Vertical Elements require two people to align and install each 8' blade safely. Blades cannot be used to support any other material. Blades can be rotated 180 degrees.

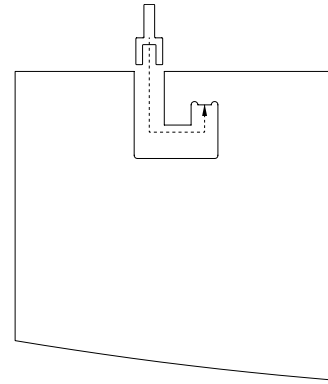

Each blade is attached to the suspension system by means of hanging the factory hook cut out in the blade over the vertical flange of the suspension bar.

The suspension bar allows for rows of blades every 4". Joints between panels should be staggered between blade runs as shown below.

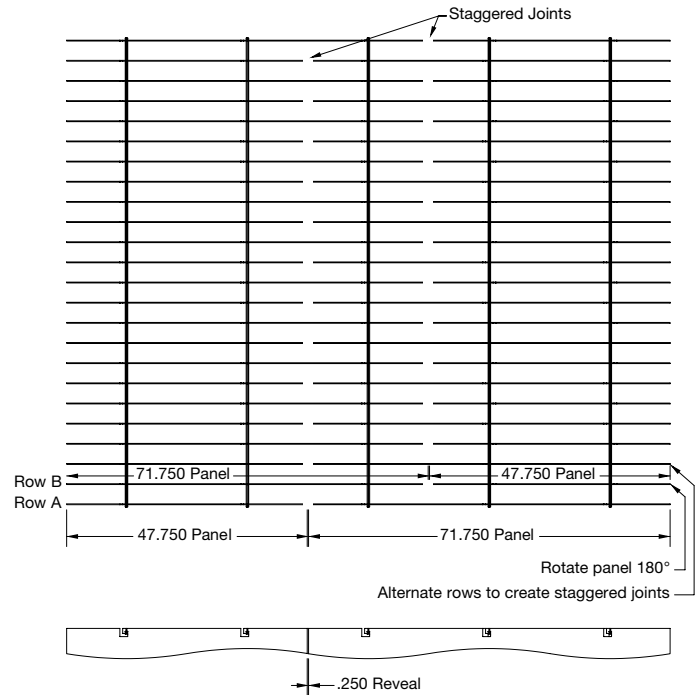

The Infusions Blades Concepts wave design is a 4' pattern.

6' blades should only be installed end-to-end with 4' or 8' blades in order to keep the wave design pattern. (Refer to section 1.1 for blade profiles at 4', 6', and 8' lengths).

4' and 8' Blades can be installed in the same direction or in alternating directions as shown below.

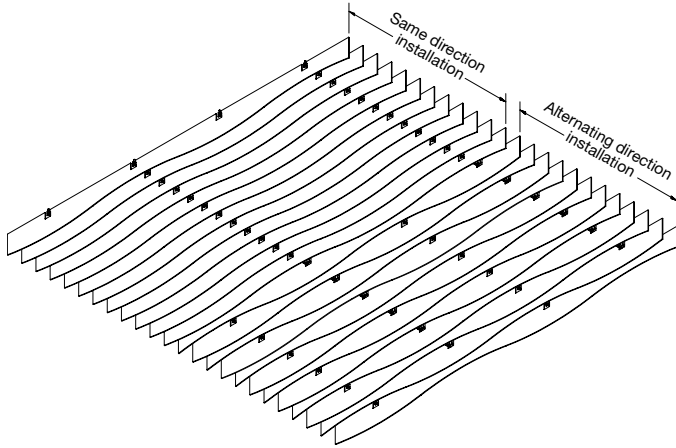

Product classified as an “architectural element” (no bracing is needed)

- must be able to swing 360 degrees
- must not be allowed to contact essential components in the ceiling
- since aircraft cables are used the maximum swing that can be expected is 18"

4. SEISMIC

This system has been tested and approved for installation in all IBC Seismic Design Categories. ASCE 7 provides an exception to the restraint requirement for architectural components stated in section 13.5.1, provided that:

- The connection to the structure shall allow a 360° range of motion in the horizontal plane
- The component may not cause damage to an essential building element

(refer to p.17 in the Armstrong “What You Need to Know” document regarding seismic installations).

The International Building Code allows architectural components to swing freely as long as they will not be damaged or cause damage. Cable lengths less than 20" will generate the greatest amount of pendulum reaction during a seismic event and should, therefore, be avoided.

When it is not practical to use cables greater than 20" long, allow lateral clearance around the architectural component equal to, or greater than, the length of the cable.

Architectural components suspended from cables greater than 20" long will swing no more than 8". Restraint of canopies has proven to be ineffective and is not recommended.

OSHPOD/DSA installations may require additional attachment from blade to suspension bar. Standard blades do not come with pilot holes pre-drilled, however, blades can be ordered with pre-drilled pilot holes adjacent to the hook details (as shown in detail below) by contacting TechLine at 1 877 ARMSTRONG. 18 gauge hanger wire should be inserted to bridge over the suspension bar and the ends twisted together with four turns.

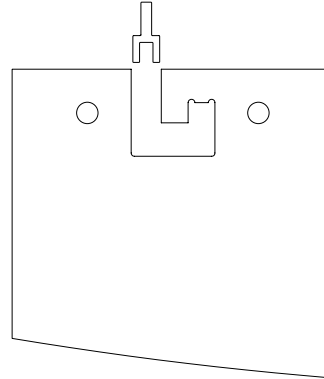

5. CLEANING

Avoid wiping the blade surfaces with abrasive compounds of any type.

Infusions® Blades – Concepts™ should be handled with clean gloves/hands to avoid fingerprints. **PLEASE NOTE:** This is especially important with the printed panels to avoid scratches or fingerprints on the more clear part of the visuals.

Static charges that may build up after removing protective film can be removed by wiping the blade with a cloth dampened with water.

Lightly dust with a duster or soft, clean cloth first. Keep the cleaning cloth free of grit.

Caution: Do not allow blade edges to get wet when cleaning the blade surface. This would damage the blade and void the product warranty.

MORE INFORMATION

For more information, or for an Armstrong representative, call 1 877 ARMSTRONG.

For complete technical information, detail drawings, CAD design assistance, installation information, and many other technical services, call TechLine™ services at 1 877 ARMSTRONG or FAX 1 800 572 TECH.

For the latest product selection and specification data, visit armstrong.com/infusions

All trademarks used herein are the property of AWI Licensing Company and/or its affiliates
© 2016 AWI Licensing Company • Printed in the United States of America

BPLA-297962-216

Armstrong[®]
CEILING SYSTEMS