

TECTUM® DesignArt™ - Shapes Ceiling & Wall Panels

Assembly and Installation Instructions

1. GENERAL

1.1 Product Description

Tectum® DesignArt™ - Shapes ceiling and wall panels are highly impact-resistant panels made of Aspen wood fibers held together with a cementitious binder. Standard Tectum DesignArt - Shapes panels for walls and ceilings are 1" thick and come in 30 different shapes and sizes. All panels have a beveled edge profile on all sides (*Fig 1*).

Custom panels are available in additional sizes and thicknesses upon request.

Standard panels are available in 30 shapes, categorized into five groups: Circles, Squares & Rectangles, 30-Degree Shapes, 45-Degree Shapes, and 60-Degree shapes. Shapes panels are available in multiple sizes of triangles, parallelograms, hexagons, circles, and squares that can be mixed and matched to create interesting and dynamic patterns in the ceiling. Standard panels are available in 24 paint colors and Natural finish. Please note, panels will show normal color variation due to the wood fibers. See the data page for shape and color visuals.

Tectum DesignArt - Shapes panels can be installed on the ceiling and on walls. All panels will be direct-attached to an existing drywall or plywood surface. See Section 4 for more details on installation. Panels can be field cut and field painted up to six times without impacting acoustic or fire performance (see Section 5.5).

1.2. Safety

This product is made of wood fibers and cementitious binder. Sawing, sanding, or machining these products can produce wood dust and crystalline silica. Airborne dust can cause respiratory, eye, and skin irritation. Respirable wood dust and crystalline silica are classified as carcinogens. Personal protective equipment includes safety glasses or goggles, and impervious gloves. Respiratory protection may be required and depends on how the product is being cut and handled. Job site environmental conditions must be evaluated in determining what type of respiratory protection is required. In all cases, cutting is to be performed in a well-ventilated area and power tools must be equipped with a dust collection system. Refer to the Safety Data Sheet on www.armstrongceilings.com/tectum for additional information.

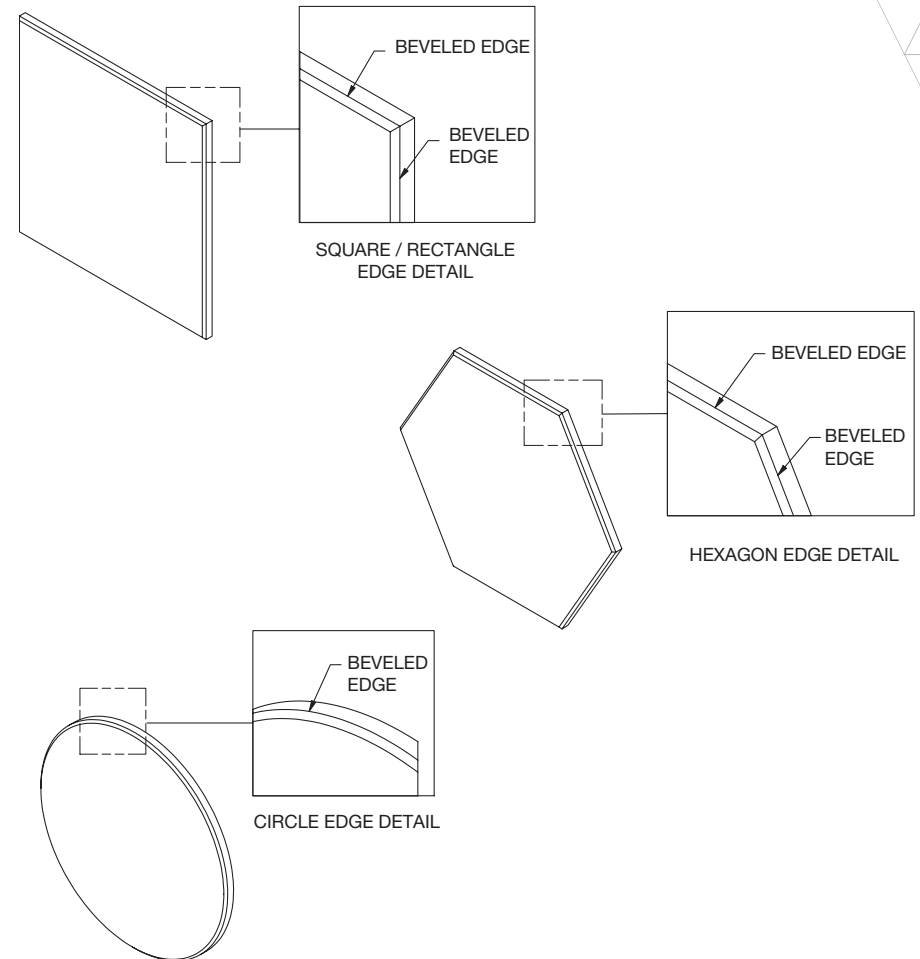

(Fig 1)

1.3. Warranty

Failure to follow the Armstrong® Ceilings recommended installation instructions in effect at the time of installation may void the product and/or ceiling system warranty.

1.4. Surface Finish

Tectum® panels are made of wood fibers within a cementitious binder. White panels are finished with a latex-based paint. Due to the unique porous composition of Tectum panels, they can be field painted up to six times without negatively impacting acoustic or fire performance.

1.5. Storage & Handling

Panels should be stored in a dry interior location and must remain in cartons prior to installation to avoid damage. The cartons should be stored in a flat, horizontal position.

Proper care must be taken when handling to avoid damage and soiling. Do not store in unconditioned spaces with humidity greater than 85% or lower than 25% RH, and temperatures lower than 32°F or greater than 120°F. Panels must not be exposed to extreme temperatures, for example, close to a heating source or near a window where there is direct sunlight.

1.6. Site Conditions

Tectum panels are required to reach room temperature and have stabilized moisture content for a minimum of 72 hours before installation. They should not, however, be installed in spaces where the temperature is lower than 32°F or greater than 120°F, or when humidity conditions are greater than 85% or lower than 25% RH. Panels must not be exposed to extreme temperatures, for example, close to a heating source or near a window where there is direct sunlight. All wet work (plastering, concrete, etc.) must be complete and dry.

1.7. HVAC Design & Operation, Temperature & Humidity Control

Real wood and wood composite products are natural building materials, and they will react to changes in humidity. Spaces with installed product should be maintained with humidity in a range between 25% and 85% RH and temperatures in a range between 32°F and 120°F. Wood tends to contract with lower humidity and expand with higher humidity. Cementitious wood fiber panels may also tend to warp, twist, or bow, due to the natural stresses in the components and these humidity changes. Be aware of these natural tendencies when evaluating the products. It is also necessary for the area to be enclosed and for the HVAC systems to be functioning and in continuous operations for the life of the product. All wet work (plastering, concrete, etc.) must be complete and dry. Standard 1" Tectum panels cannot be used in exterior applications. Contact TechLine for information on custom Tectum products available for exterior installations.

1.8. Colors

Standard Tectum panels are available in 24 paint colors and Natural finish. Due to the natural variation of Tectum wood fibers, panels in Natural finish will have normal color variation from panel-to-panel and within panels.

Panels can be field painted up to six times without losing their acoustical or fire performance. See Section 5.5 for field painting guidelines. Factory-finished custom colors are also available.

1.9. Ordering Considerations

Be sure to account for extra material that is normally needed for wood installations. When installing Tectum® DesignArt™ panels, consider ordering at least 5% extra material.

Up to 10% more may be needed for odd size or painted installations. It is the customer's responsibility to plan each layout and order the correct amount of installation material needed, taking into account their design.

2. DESIGN CONSIDERATIONS

2.1. Directionality

Tectum DesignArt – Shapes panels are directional based on the shape of the panel and the pattern in the installation. Panels can be installed in any direction to achieve the desired design. Consult the project's RCP for specific details pertaining to the pattern.

2.2. Edges

All panels and shapes are beveled on all sides.

2.3. Pool Installations

Tectum DesignArt ceiling panels are not to be used in pool or other high humidity areas where standing water is present. Contact TechLine for information on Tectum products available for pool installations.

2.4. Exterior Installations

Tectum DesignArt ceiling and wall panels are not intended for exterior use.

2.5. Direct Attachment

Tectum DesignArt panels are mechanically fastened to furring (metal or wood) or direct to structure using appropriate fasteners. See Installation Section 4 for different mounting methods. DesignArt panels are approximately 1.65 lbs./SF. Correct fasteners should consider total system weight. For acoustical solutions, reference C-20 and C-40 mounting. Do not countersink screws or fasteners into panel face. The type and position of framing and furring will be specified by the contractor.

3. TECTUM ACCESSORIES

3.1. Screws

Armstrong® Ceiling and Wall Systems offers three types of screws for many common installation methods. For specific installation instructions, including which screw for furring to structure connection and spacing, please see Section 4.

Sharp point screws (Item 8187L16, *Fig 2*) are 1-5/8" long and are available in coordinating factory-finished White (suffix TWH) or Natural (suffix TNA). For 20- and 25-light-gauge steel framing, wood furring, or Armstrong Ceilings drywall grid, use 1-5/8" sharp point drywall screws.

Drill point screws (Item 8188L16, *Fig 3*) are 1-5/8" long and are available in coordinating factory-finished White (suffix TWH) or Natural (suffix TNA). For 20-gauge structural and heavier steel decking or framing, use 1-5/8" self-drilling drywall screws.

Cement Masonry Unit (CMU) Screws (Item 8189L22, *Fig 4*) are 2-1/4" long and are available in coordinating factory-finished White (suffix TWH) or Natural (suffix TNA). For hollow block CMU (Cement Masonry Unit or breeze/cinder block) structures, use 2-1/4" masonry screws. See specific installation guidance in Section 4.1.

To attach Tectum® panels to structures or surfaces not listed in this section, please contact a fastener manufacturer, such as Hilti™, Fastenal®, or Tapcon® to obtain guidance and engineering data support.

3.2. Adhesive

Armstrong Ceiling and Wall Solutions recommends Titebond® GREENchoice or Henry® 237 AcoustiGum™ Acoustical Ceiling Tile Adhesive when using the direct-applied adhesive installation method. The adhesive will be supplied by the contractor.

3.3. Touch up Paint

Touch up paint for 24 standard paint colors is available. Custom touch up paint is also available upon request.

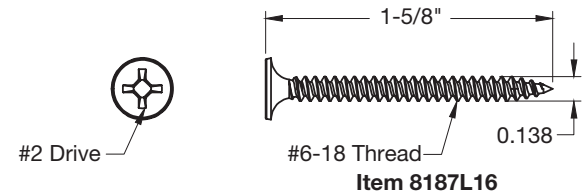

(Fig 2)

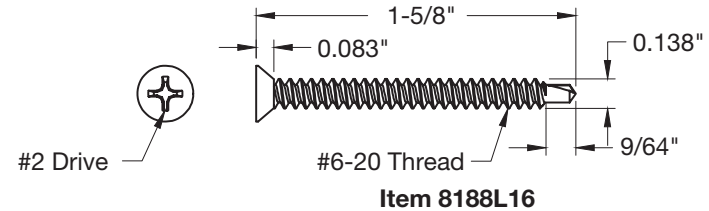

(Fig 3)

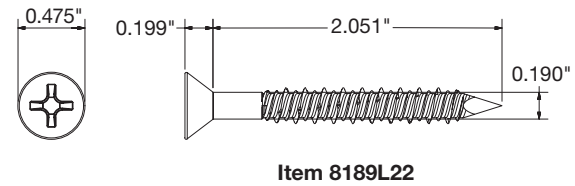

(Fig 4)

4. INSTALLATION OPTIONS

4.1. Direct-Attach Ceiling or Wall Installation

4.1.1. For Tectum® DesignArt™ panels, one of the most common application methods for Tectum interior panels is screw attachment to furring. The furring can be either wood or metal. DesignArt panels are approximately 1.65 lbs./SF. Consider total system weight when determining fasteners. The furring enables improved sound absorption and allows the installer to fasten in areas where there could otherwise be obstructions. The use of screw attachment for interior panels is widely accepted. The proper installation of the screws results in an installation where the heads are difficult to find even when viewed from a short distance. The Phillips flathead screws are painted to match either the painted White panels or the Natural panels. The screws are installed so that the screw head is flush with the surface of the Tectum panel.

Do not countersink the screw heads. The texture of Tectum® panels helps hide the screw head. This installation section will review the different mounting methods and fastener recommendations.

The NRC requirements will dictate what mounting method should be used. Verify specifications or drawings to determine project requirements. There are four direct mounting methods and each of them will have specific installation requirements so the Tectum system can meet project NRC specifications.

4.1.2. Mounting Method A (Fig 5)

Mounting Method A requires installing panels directly to a wall or ceiling structure with no furring or space behind the Tectum panels. Please consult this section for type of screw (CMU/Drill Point/Sharp Points) and Section 4.1.6 for spacing requirements (for both Standard Interior and High-Impact/Abuse applications). Because ceiling and wall structure materials vary greatly, Armstrong World Industries does not offer fasteners for all project applications but does provide fasteners for the most common structures. Depending on what the substrate is, there are different recommendations for which fastener to use.

For one of the most common structure materials, CMU (hollow Cement Masonry Unit, or breeze/cinder block), use Tectum 2-1/4" CMU Screw (Item 8189L22). While the CMU screw will work in most concrete block applications, it is important to note that it will not work with all concrete. It is difficult or impossible to use this screw with some poured or precast concrete. Work with a fastener manufacturer to determine best fastener for your application and to acquire engineering reports regarding performance. Contact Armstrong Ceilings TechLine or Tapcon® if specific guidance is needed related to drill bits, anchors, or general CMU screw installation.

For structures other than hollow CMU, contact a fastener manufacturer, such as Hilti™, Fastenal®, or Tapcon® to get guidance and engineering support data on the fastener type that will meet pull-out requirements for your building code.

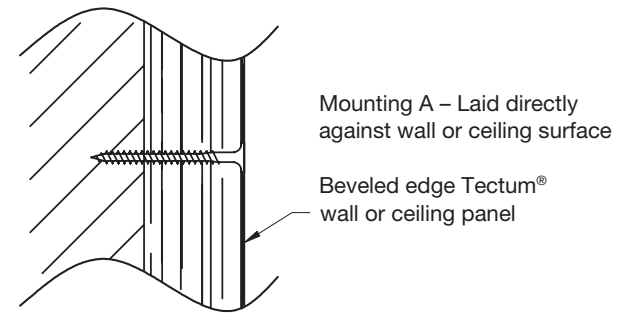

(Fig 5)

IMPORTANT NOTES:

Power-Actuated Fasteners: Do not use power actuated fasteners to directly attach Tectum panels to masonry surfaces. If power actuated fasteners are necessary, they should be used on the furring/hat channel and panels screw-attached to the furring as described in steel framing and wood furring Section 4.1.3.

Exterior Masonry Walls: If you encounter uninsulated exterior walls, or if you are uncertain of the insulation conditions of the wall, use furring strips to ensure an air gap between panels and the structure to minimize unwanted condensation-related issues.

4.1.3. Mounting Method D-20 (Fig 6)

The D-20 direct-attach mounting method includes beveled-edge panels laid on 3/4" furring strips, or Drywall Grid (Item 8906 main beam and XL8945 cross tees) to maintain air gap between structure and back of the Tectum panels. The furring must be attached to structure in a method that supports the full weight of the panels per the requirements specified in Section 4.1.6.

Contact a fastener manufacturer, such as Hilti™, Fastenal® or Tapcon® to ensure the correct fastener for the structure type, since structure fastener requirements can vary. Due to joist/stud spacing in most jobs, to meet fastener layout requirements furring strips are recommended to ensure a secure fastening location for the panels. If you are attaching to existing drywall, all fasteners must go into a stud, drywall grid, or other structural component. It is the responsibility of the contractor to locate these elements in either ceiling or wall applications.

Please consult the following sections for attaching the Tectum® panels to the type of furring selected (Drill Point/Sharp Points) and Section 4.1.6 for spacing requirements (for standard interior or high impact/abuse spaces):

Attach Tectum panels directly to 3/4" wood or metal hat channel furring (see Section 4.1.6 for screw spacing/guidance):

- Wood furring: In a D-20 mounting, to attach to wood furring, use Tectum 1-5/8" sharp point screws (Item 8187L16) with coordinating painted face
- Light Gauge (20-25 gauge) Metal furring/framing: In a D-20 mounting, attach to thin gauge metal furring with Tectum 1-5/8" sharp point screws (Item 8187L16) with coordinating painted face
- Drywall Grid furring: In a D-20 mounting, attach to thin-gauge metal furring with Tectum 1-5/8" sharp point screws (Item 8187L16) with coordinating painted face
- Heavy-gauge metal furring: In a D-20 mounting, attach to heavy gauge metal furring with Tectum 1-5/8" drill point screws (Item 8188L16) with coordinating painted face

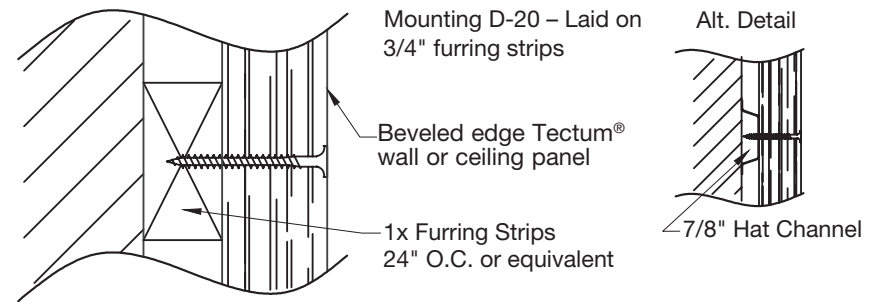

(Fig 6)

4.1.4. Mounting Method C-20 (Fig 7)

The C-20 direct-attach mounting method includes beveled edge panels laid on 3/4" furring strips with 1", 3-lb. density fiberglass batt insulation between the furring, which increases the acoustic absorption of the installed space (NRC). The furring must be attached to structure in a method that supports the full weight of the panels per the requirements specified in Section 4.1.6. Contact a fastener manufacturer, such as Hilti™, Fastenal®, or Tapcon® to ensure the correct fastener for the structure type, since structure fastener requirements can vary. Due to joist/stud spacing in most jobs, to meet fastener layout requirements furring strips are recommended to ensure a secure fastening location for the panels.

If you are attaching to existing drywall, all fasteners must go into a stud, drywall grid, or other structural component. It is the responsibility of the contractor to locate these elements in either ceiling or wall applications.

Please consult the following sections for attaching the Tectum panels to the type of furring selected (Self-drilling/Sharp point) and Sections 4.1.6 and 4.1.7 for spacing requirements (for standard interior or high impact/abuse spaces).

Attach Tectum® panels directly to 3/4" wood or metal furring (see Section 4.1.6 for screw spacing/guidance):

- Wood furring: In a C-40 mounting, to attach to wood furring, use Tectum 1-5/8" sharp point screws (Item 8187L16) with coordinating painted face
- Light-gauge (20-25 gauge) metal furring/framing: In a C-40 mounting, attach to thin-gauge metal furring with Tectum 1-5/8" sharp point screws (Item 8187L16) with coordinating painted face
- Drywall Grid furring: In a C-40 mounting, attach to thin-gauge metal furring with Tectum 1-5/8" sharp point screws (Item 8187L16) with coordinating painted face
- Heavy-gauge metal furring or structural steel: In a C-40 mounting, attach to heavy-gauge metal furring with Tectum 1-5/8" drill point screws (Item 8188L16) with coordinating painted face

Please consult the following sections for attaching the Tectum panels to the type of furring selected (Drill Point/Sharp Point) and Section 4.1.6 for spacing requirements (for standard interior or high impact/abuse spaces):

Attach Tectum panels directly to 3/4" wood or metal furring (see Section 4.1.6 for screw spacing/guidance):

- Wood furring: In a C-20 mounting, to attach to wood furring, use Tectum 1-5/8" sharp point screws (Item 8187L16) with coordinating painted face
- Light-gauge (20-25 gauge) metal furring/framing: In a C-20 mounting, attach to light-gauge metal furring with Tectum 1-5/8" sharp point screws (Item 8187L16) with coordinating painted face
- Drywall Grid furring: In a C-20 mounting, attach to thin-gauge metal furring with Tectum 1-5/8" sharp point screws (Item 8187L16) with coordinating painted face
- Heavy-gauge metal or structural steel: In a C-20 mounting, attach to heavy-gauge metal furring with Tectum 1-5/8" drill point screws (Item 8188L16) with coordinating painted face

Contact a fastener manufacturer, such as Hilti™, Fastenal®, or Tapcon® to ensure the correct fastener for the structure type, since structure fastener requirements can vary.

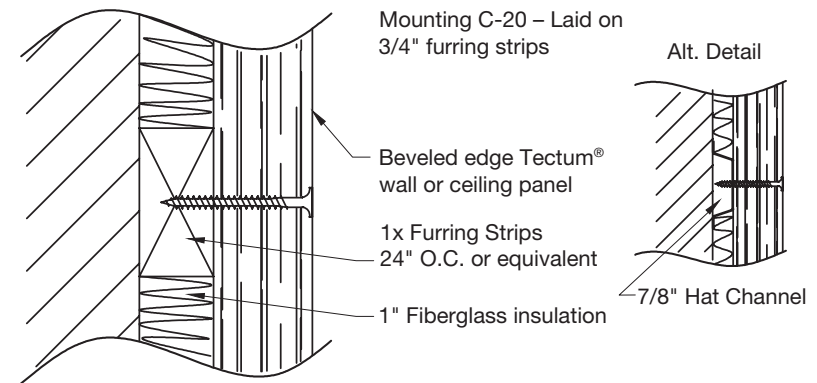

(Fig 7)

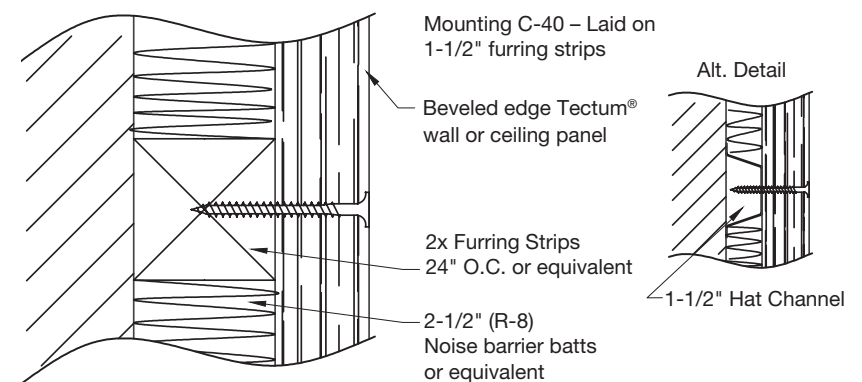

(Fig 8)

4.1.5. Mounting Method C-40 (Fig 8)

The C-40 direct-attach mounting method includes beveled-edge panels laid on 1-1/2" furring strips with 2-1/2" batt insulation between the furring, which increases the acoustic absorption of the installed space (NRC). The furring must be attached to structure in a method that supports the full weight of the panels per the requirements specified in Section 4.1.6. Contact a fastener manufacturer, such as Hilti™, Fastenal®, or Tapcon® to ensure the correct fastener for the structure type, since structure fastener requirements can vary.

Due to joist/stud spacing in most jobs, to meet fastener layout requirements furring strips are recommended to ensure a secure fastening location for the panels. If you are attaching to existing drywall, all fasteners must go into a stud, drywall grid, or other structural component. It is the responsibility of the contractor to locate these elements in either ceiling or wall applications.

4.1.6. Screw Placement for All Mounting Methods

The 1" thick standard Tectum® DesignArt™ ceiling and wall panel has a weight of 1.65 lbs./SF. It is the contractor/installer's responsibility to ensure type of fastener and placement can carry the system weight. Additionally, the Tectum® panel surface is not intended to support additional weight. Because the pull-through resistance of the screw head is adequate, no washers or adhesive application is required.

Tectum panels are typically installed over furring, but the same screw pattern should be used for a Mounting Method A direct mounting. The layout for the furring will be based on the installation layout and the Shapes being used. View the chart in (Fig 9) to see the prescribed number of screws required per panel. The attachment of the furring must be designed to support the weight of the panels. When attaching to furring use painted head drywall screws. The screws are to be spaced 1" from the panel edges.

4.1.7. High Impact Areas

View the chart in (Fig 9) to see the prescribed number of screws required per panel for high impact areas.

4.2. Direct-Applied – Adhesive Wall Installation

4.2.1. DesignArt panels can also be installed in wall applications only using construction adhesive. Armstrong® Ceiling and Wall Solutions recommends Titebond® GREENchoice or Henry® 237 AcoustiGum™ Acoustical Ceiling Tile Adhesive when using the direct-applied adhesive installation method. The adhesive will be supplied by the contractor.

The Direct-Applied - Adhesive installation method is limited to wall installations only. Panels cannot be installed in ceiling applications using construction adhesive. The maximum panel size for this installation method is 24" x 48" x 1". Larger and/or thicker panels cannot be installed using construction adhesive. The adhesive attachment is not to be used in swimming pool installations.

4.2.2. Please follow adhesive manufacturer's instructions for application and usage. It is recommended to test and confirm suitability prior to installation. Armstrong does not guarantee the performance of these or other adhesive products, either alone or in conjunction with Armstrong products.

Item Number	Panel Description	Number of Screws / Panel	Number of Screws / Panel in High Impact Areas
5420R01T10	Square – 12" x 12"	2	4
5420R02T10	Rectangle – 12" x 24"	4	6
5420R03T10	Rectangle – 12" x 36"	4	6
5420R04T10	Rectangle – 12" x 48"	6	8
5420R05T10	Square – 24" x 24"	4	8
5420R06T10	Rectangle – 24" x 48"	6	12
5420C01T10	Circle – 12"	2	4
5420C02T10	Circle – 24"	3	4
5420C03T10	Semicircle – 6" x 12"	2	3
5420C04T10	Semicircle – 12" x 24"	2	4
5420T01T10	45 Degree Right Triangle – 12" x 12"	2	3
5420T02T10	45 Degree Right Triangle – 24" x 24"	3	4
5420T01T10	45 Degree Parallelogram – 12" x 24" - Right	2	4
5420T02T10	45 Degree Parallelogram – 24" x 48" - Right	4	8
5420P03T10	45 Degree Parallelogram – 12" x 24" - Left	2	4
5420P04T10	45 Degree Parallelogram – 24" x 48" - Left	4	8
5420H01T10	Hexagon – 12" x 14"	2	4
5420H02T10	Hexagon – 24" x 28"	4	6
5420Z01T10	Trapezoid – 6" x 14"	2	4
5420Z02T10	Trapezoid – 12" x 28"	4	6
5420T03T10	60 Degree Equilateral Triangle – 12" x 14"	2	3
5420T04T10	60 Degree Equilateral Triangle – 24" x 28"	3	4
5420T05T10	60 Degree Right Triangle – 12" x 7" - Right	2	3
5420T06T10	60 Degree Right Triangle – 24" x 14" - Right	3	4
5420T07T10	60 Degree Right Triangle – 12" x 7" - Left	2	3
5420T08T10	60 Degree Right Triangle – 24" x 14" - Left	3	4
5420P05T10	60 Degree Parallelogram – 24" x 14"	4	5
5420P06T10	60 Degree Parallelogram – 48" x 28"	4	8
5420T11T10	30 Degree Isosceles Triangle – 24" x 7"	3	4
5420T12T10	30 Degree Isosceles Triangle – 48" x 14"	3	5

(Fig 9)

4.2.3. Surfaces must be dry and free of dust, grease, oil, dirt, or any other material that may deter adhesion when using the adhesive installation method. Existing finish paint must be well bonded and not flaking or peeling; otherwise, it must be removed. Avoid applying to a newly painted ceiling/deck. Glossy painted surfaces must be abraded. For painted or sealed surfaces, install a small test area and observe after 12 hours.

4.2.4. Using a trowel with 1/4" x 1/2" x 1/4" notches, apply the adhesive to the locations per the panel you are using. View the chart in (Fig 10) to see the prescribed number of adhesive squares and the size of each adhesive square per panel. The adhesive square should be no more than 3" away from the edge of the panel.

4.2.5. It is recommended to use an alignment method (i.e., laser, chalk line) to make sure the panels are properly positioned during installation.

4.2.6. Once in position, push the panel against the drywall or plywood applying even hand pressure to the panel where the adhesive is located, starting at the center first, and then working to the edges. By attaching the center first, the installer can still pivot the panel slightly left or right before adhering the edges. This ensures that the panel can be aligned correctly first before the edges are solidified into place. Avoid excessive pressure to minimize panel flexing that will disturb the previously pressed areas of adhesive and result in release of the adhesive. Lastly, press a sponge float across all areas of the panel where glue was applied to ensure all glue spots are properly compressed and adhered to the drywall.

4.2.7. Any slight adjustments to the panel placement should be done immediately to not weaken the adhesive bond. Once the panel is evenly pressed into position, the adhesive should provide an immediate bond to hold the panel in place while the adhesive sets.

4.2.8. Install finishing screws to the panel once it is in the correct location to ensure that the panel does not slide down the wall. Countersink finishing screws into the Tectum panels no more than 1/4". Finishing screws are supplied by others.

4.2.9. In moderate or high impact areas, such as gymnasium walls less than 12 feet above the floor, additional screws are recommended.

5. PANELS

5.1. Edge Detail

All panels are beveled on all sides.

5.2. Field Cutting

Cut the panel using standard woodworking tools and techniques. A table saw is recommended for straight cuts and a band saw for curved cuts. In both cases, panels should be cut face up to minimize chipping of the face veneer.

To replicate the 1/4" factory bevel, a hand router with a 1/4" bevel bit can be used. Fine-toothed blades recommended for finish cuts will yield the best results.

Item Number	Panel Description	Number of Glue Squares	Each Glue Square Size
5420R01T10	Square – 12" x 12"	1	5" x 5"
5420R02T10	Rectangle – 12" x 24"	2	5" x 5"
5420R03T10	Rectangle – 12" x 36"	3	5" x 5"
5420R04T10	Rectangle – 12" x 48"	4	5" x 5"
5420R05T10	Square – 24" x 24"	4	5" x 5"
5420R06T10	Rectangle – 24" x 48"	8	5" x 5"
5420C01T10	Circle – 12"	1	5" x 5"
5420C02T10	Circle – 24"	4	5" x 5"
5420C03T10	Semicircle – 6" x 12"	2	3" x 3"
5420C04T10	Semicircle – 12" x 24"	2	5" x 5"
5420T01T10	45 Degree Right Triangle – 12" x 12"	3	2" x 2"
5420T02T10	45 Degree Right Triangle – 24" x 24"	3	4" x 4"
5420T01T10	45 Degree Parallelogram – 12" x 24" – Right	4	3" x 3"
5420T02T10	45 Degree Parallelogram – 24" x 48" – Right	4	5" x 5"
5420P03T10	45 Degree Parallelogram – 12" x 24" – Left	4	3" x 3"
5420P04T10	45 Degree Parallelogram – 24" x 48" – Left	4	5" x 5"
5420H01T10	Hexagon – 12" x 14"	1	5" x 5"
5420H02T10	Hexagon – 24" x 28"	4	5" x 5"
5420Z01T10	Trapezoid – 6" x 14"	2	3" x 3"
5420Z02T10	Trapezoid – 12" x 28"	2	5" x 5"
5420T03T10	60 Degree Equilateral Triangle – 12" x 14"	1	4" x 4"
5420T04T10	60 Degree Equilateral Triangle – 24" x 28"	3	5" x 5"
5420T05T10	60 Degree Right Triangle – 12" x 7" – Right	2	2" x 2"
5420T06T10	60 Degree Right Triangle – 24" x 14" – Right	3	3" x 3"
5420T07T10	60 Degree Right Triangle – 12" x 7" – Left	2	2" x 2"
5420T08T10	60 Degree Right Triangle – 24" x 14" – Left	3	3" x 3"
5420P05T10	60 Degree Parallelogram – 24" x 14"	2	4" x 4"
5420P06T10	60 Degree Parallelogram – 48" x 28"	4	6" x 6"
5420T11T10	30 Degree Isosceles Triangle – 24" x 7"	3	3" x 3"
5420T12T10	30 Degree Isosceles Triangle – 48" x 14"	3	5" x 5"

(Fig 10)

5.3. Directionality

Tectum® DesignArt™ – Shapes panels are directional based on the shape of the panel and the pattern in the installation. Panels can be installed in any direction to achieve the desired design. Consult the project's RCP for specific details pertaining to the pattern.

5.4. Acoustic Infill for Direct-Attach Panels

Sound Absorption (NRC) of up to 0.85 can be achieved with 1" thick standard Tectum Direct-Attach panels. See Section 4.1, C-20 and C-40 mounting methods.

5.5. Field Painting

Field Painting Specification Recommendation:

Sherwin-Williams® Product: SHERWOOD® Dry Fall Brilliant Flat White (E60WL501), or a vinyl acrylic latex paint intended as an interior brilliant white flat dry fall.

Tests have shown that six coats of spray-applied paint have no negative impact on the acoustical and fire properties of the Tectum panels.

Recommended Spread Rate per Coat

Wet Mils: 3.0 - 4.0

Dry Mils: 1.0 - 1.4

Coverage: approximately 558 ft²/gal at 1.0 mil dry film, no loss (based on flat surface)

If necessary, cross spray at multiple angles.

Surface Preparation

Surface must be clean, dry, and in sound condition. Remove all oil, dirt, grease, and other foreign material to ensure adequate adhesion.

Application Condition

Temperature: 50 deg. F minimum, 110 deg. F maximum (air, surface, and material); At least 5 deg. F above dew point

Relative Humidity: 75% maximum

Dry Time: 20 minutes to 1 hour

Recoat: 1 hour

During the early stages of drying, the coating is sensitive to rain, dew, high humidity, and moisture condensation. Plan painting schedules to avoid these influences during the first 16-24 hours of curing.

Dry fall characteristics will be adversely affected at temperatures below 77 deg. F or above 50% relative humidity.

Application Equipment

The following is a guide. Changes in pressure and tip sizes may be needed for proper spray characteristics.

Airless Spray

Pressure: 1500 psi minimum

Hose: 1/4" ID

Tip: 0.013 - 0.017 fine finishing tip

Reduction: No reduction needed.

Conventional Spray

Gun: Binks 95

Fluid Nozzle: 63C

Air Nozzle: 63PB

Atomization Pressure: 35 - 45 psi

Fluid Pressure: 8 - 10 psi

Reduction: As needed up to 20% by volume

Brush and Roller: Not recommended for the face of the product

Field Touch Up and Color Match:

Standard White Color Match: Sherwin-Williams® #SW7005

Standard Natural Color Match: Sherwin-Williams #SW6126

Direct-Attach Ceiling and Wall Panels: Tectum® panels should be fastened in place prior to field painting.

6. SPECIAL INSTALLATION CONSIDERATIONS

6.1. Discontinuous / Floating Installation

Direct-Attach discontinuous ceiling installations are not recommended.

6.2. Sloped Installation

Sloped ceiling installations should follow the prescribed number of screws in *(Fig 9)* for standard ceiling installation per Section 4.1.6.

6.3. Pool/Natatorium Installation

1" Tectum® ceiling panels are not to be used in pool or other high humidity areas where standing water is present. Contact TechLine for information on Tectum products available for pool installations.

6.4. Exterior Installation

1" Tectum panels are not intended for exterior use. Contact TechLine for information on exterior installations.

7. SEISMIC INSTALLATIONS

7.1. Direct-Attach Ceiling and Wall Panels

Seismic installations of Direct-Attach 1" thick Tectum panels are to be handled per building code.

MORE INFORMATION

For more information, or for an Armstrong Ceilings representative, call 1 877 276-7876.

For complete technical information, detail drawings, CAD design assistance, installation information, and many other technical services, call TechLine customer support at 1 877 276-7876 or FAX 1 800 572-TECH.

Hilti® is a registered trademark of Hilti Corporation; Tapcon® is a registered trademark of ITW Brands; Fastenal® is a registered trademark of Fastenal Company; all other trademarks used herein are the property of AWI Licensing LLC and/or its affiliates.
© 2022 AWI Licensing Company Printed in the United States of America

BPLA-293082-1022

