

# INTERSECTION DOWNLIGHTING

## 4" Square Downlights for 9/16" Suspension Systems

### Assembly and Installation Instructions

#### 1. GENERAL

##### 1.1 Product Description

Intersection Downlighting is a pre-engineered suspension system that seamlessly integrates recessed downlights at the intersection of the ceiling grid. We offer an integrated 4" frame for downlight integration compatible with our 9/16" grid profiles and notched 2' x 2' Calla® panels. (Frame is compatible with USAI® Lighting 4" CONNECT™ fixture).

**1.1.2** Kits are available in white and blizzard white and each carton contains eight (8) kits. With each carton, you will receive the following:

- (8) High-Profile Yokes (yokes are unassembled – 16 pieces)
- (8) Downlight Suspension Frames
- (20) Cross Tee Connection Clips (16 clips are required, 4 extra clips)

##### 1.1.3 High Profile Yoke

The High Profile Yoke is a suspension system accessory for connection to the Downlight Suspension Frame, suspension system components and support for the suspension system. The yoke allows for the entire suspension system to be installed prior to other ceiling elements.

Ceiling panels, light fixtures and all other services can be installed after the suspension system. The top of the High Profile Yoke is 8" tall. The High Profile Yoke is compatible with the USAI Lighting CONNECT™ downlight, adjustable, and wall wash options. (Fig 1)

##### 1.1.4 Low Profile Yoke

The Low-Profile yoke (FZD4YKLP) is not included in the kit and is available as a quick ship item containing 8 yokes per carton (16 pieces). The Low-Profile yoke is 4" high and can be used in areas that have a low or crowded plenum. The Low-Profile yoke is only compatible with the USAI Connect downlight and wall wash options. It cannot be used with the USAI Connect adjustable light. (Fig 2)

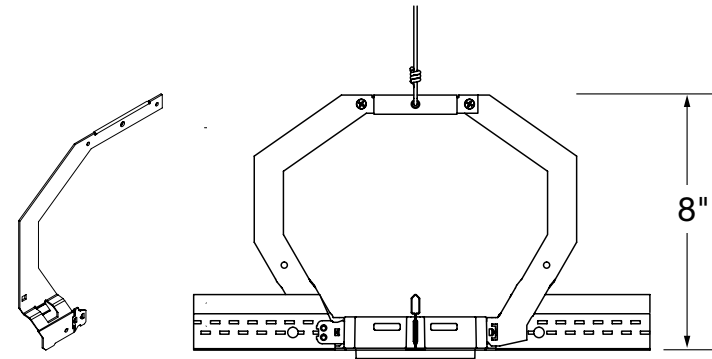

(Fig 1)

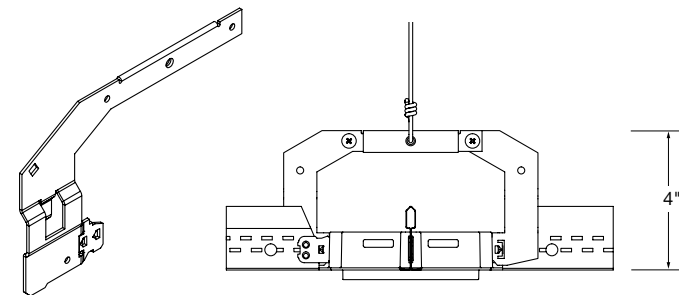

(Fig 2)

### 1.1.5 Downlight Suspension Frame

The Downlight Suspension Frame is a suspension system accessory designed to allow 4" square Downlights to be installed at the intersection of four Armstrong® cross tees.

The Downlight Suspension Frame connects the four suspension system components together, while providing an opening for the light fixture. The face of the Downlight Suspension Frame matches the profile of its corresponding 9/16" suspension system. *(Fig 3)*

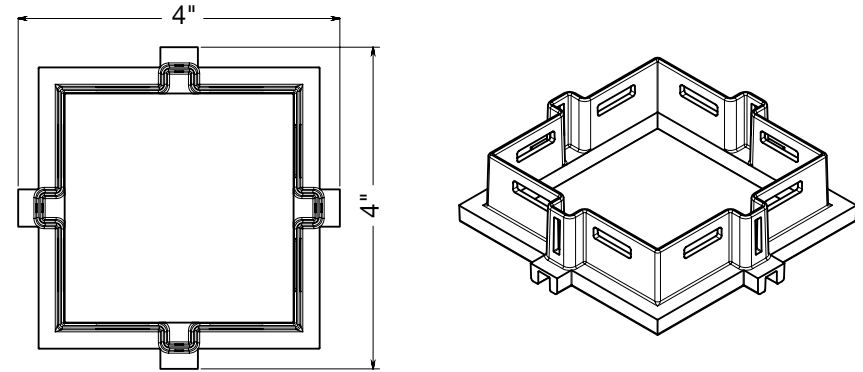

*(Fig 3)*

### 1.1.6 Cross Tee Connection Clip

The Cross Tee Connection Clip is designed to provide a code compliant connection for suspension system components, when installed with the Downlight Suspension Frame. Each Downlight Suspension Frame requires 2 clips and each carton is shipped with 20 clips, leaving 4 extra clips in the event one is damaged or misplaced. *(Fig 4)*

### 1.1.7 Notched Ceiling Tile for Intersection Downlighting

Ceiling tiles are ordered separately. The notched Calla® ceiling tile (Item 2818) is a ceiling tile that provides a factory finished notched edge detail for perfect integration with the Downlight Suspension frame, eliminating the need for field cut ceiling tiles. There are 8 tiles per carton and since the ceiling panels are directional, (4) tiles are marked with an A and (4) tiles are marked with a B. Each carton of Intersection Downlighting Kits will require 4 cartons of 2818. The coordinating full size 2' x 2' Calla ceiling panel is item 2824. *(Fig 5)*

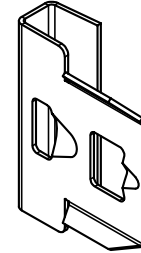

*(Fig 4)*

## 2. INSTALLATION

Find locations of the Downlight Suspension Frames (corresponds with LED downlights) on the reflected ceiling plan. Add 12 gauge soft annealed galvanized hanger wire at each Downlight Suspension Frame.

### 2.1 Main Beam Installation

Main Beam Installation Suspension system main beams should be installed prior to installation of the Downlight Suspension Frame and Directional Cross Tees. Main beams are suspended from an overhead structure, by means of minimum 12 gauge soft annealed galvanized hanger wire.

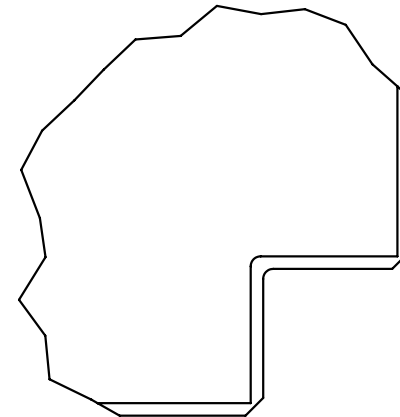

*(Fig 5)*

## 2.2 Main Beam Spacing

For 24" x 24" ceiling layout, install suspension system main beams at 4' O.C. spacing, for 4' and 8' O.C. spacing of the downlight suspension frames. Suspension system main beams must be installed in an alternating (4' spacing, 2' spacing) for 6' O.C. spacing of the Downlight Suspension Frames.

For 30" x 30" ceiling layout with lights 7-1/2' apart, install suspension system main beams alternating 60", 30" O.C.

For 30" x 30" ceiling layout with lights 5' apart, install suspension system main beams at 5' O.C. spacing.

For 48" x 48" ceiling layout with lights 8' apart, install suspension system main beams at 8' O.C. spacing.

**NOTE:** The Downlight Suspension Frame can only be connected to directional cross tees. Main beams cannot be connected to the downlight suspension frame.

## 2.3 Pre-Assembly

The Downlight Suspension Frame and yoke can be preassembled for an easier more efficient installation. The yoke comes as two separate pieces which require (2) two #7- 7/16" pan head screws for positive attachment. Each end of the yoke is installed into opposite routed openings on the Downlight Suspension Frame. (Fig 6)

Ensure the hook detail of the yoke is fully engaged in suspension frame rout. When installed properly, there will be no gap between the top of the hook detail of the yoke and the suspension frame. (Fig 7)

## 2.4 Suspension of the Frame

Hang and level the Downlight Suspension System Frame and yoke from an overhead structure by means of minimum 12 gauge soft annealed galvanized hanger wire. One hanger wire from structure is required at the center of the assembled yokes. (Fig 8)

## 2.5 Directional Cross Tee Installation at Downlight Frame with the Yoke

Install (2) two Directional Cross Tees into the routed openings on the Downlight Suspension Frame. **NOTE:** The Directional Cross Tee is labeled as directional and the non-override side of it should be connected to the Downlight Suspension Frame. When correctly installed the arrow on the Directional Cross tee will be pointed towards the Downlight Suspension Frame. For seismic D,E,F areas, a rivet is required to secure the yoke and cross tee connection. Proper installation requires the rivet to be installed through the hole in the cross tee first and then into the Cross Tee Connection Clip. (Fig 9)

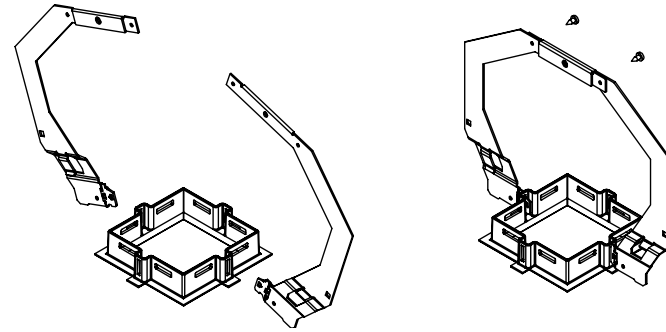

Yoke-Suspension Frame Assembly

(Fig 6)

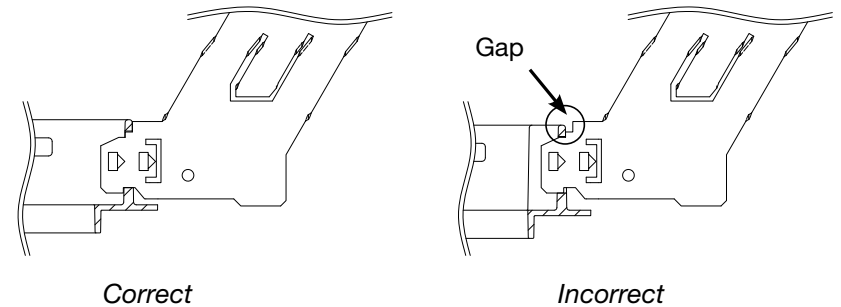

(Fig 7)

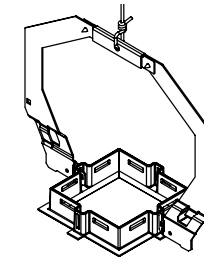

(Fig 8)

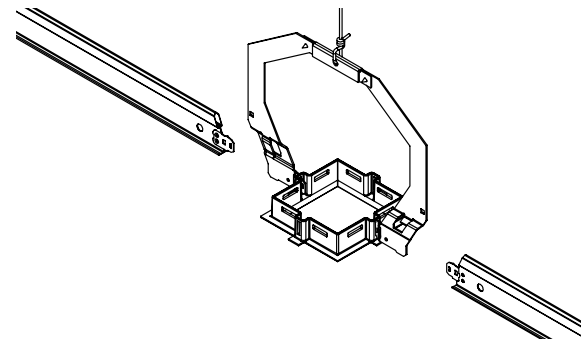

(Fig 9)

## 2.6 Directional Cross Tee Installation at Downlight Frame with Cross Tee Connection Clips

Position (2) two Cross Tee Connection Clips inside of the Downlight Suspension Frame's routed openings for connection to two (2) Directional Cross Tees (**NOTE:** the Cross Tee Connection Clips are positioned in the routed openings of the Downlight Suspension Frame, which are unoccupied by the yoke.) Hold the Cross Tee Connection Clip in place and stab the non-override side of the Directional Cross Tee into the routed opening on the Downlight Suspension Frame.

**NOTE:** The Directional Cross Tee is labeled as a directional cross tee, when correctly installed the arrow will be pointed towards the Downlight Suspension Frame. (Fig 10)

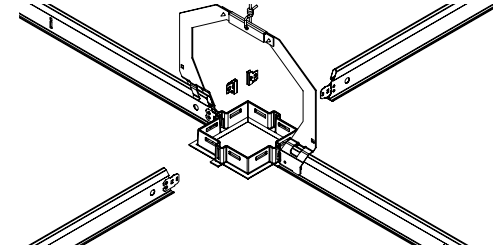

(Fig 10)

## 2.7 Lighting Fixture and Driver Installation

The compatible lighting fixture and driver should be installed by a qualified electrician. Please note, the driver is designed to be installed over the top of a Directional Cross Tee. No independent supporting wires are required on the actual light or the driver. The suspension systems are designed and tested to support the weight of the light and driver. (Fig 11)

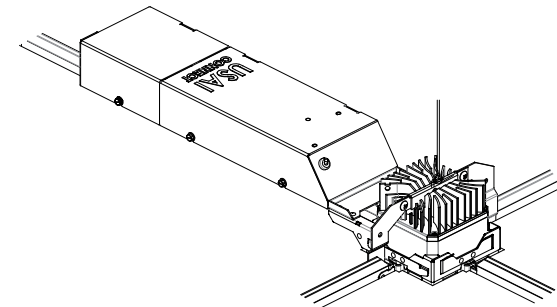

(Fig 11)

## 2.8 Ceiling Tile Installation

Factory finished notched ceiling panels should be installed after the installation of the light and driver. Armstrong® Calla® Ceiling Panels are directional. Please take note of the directional arrow on the backside of the ceiling panels when installing. There are two (2) "A" and two (2) "B" Notched Ceiling Panels for each Downlight Suspension Frame.

The "A" Calla Ceiling Panels should be installed on opposing corners of Downlight Suspension Frame. The same opposing installation method can be used when installing the "B" Calla Ceiling Panels. (Fig 12)

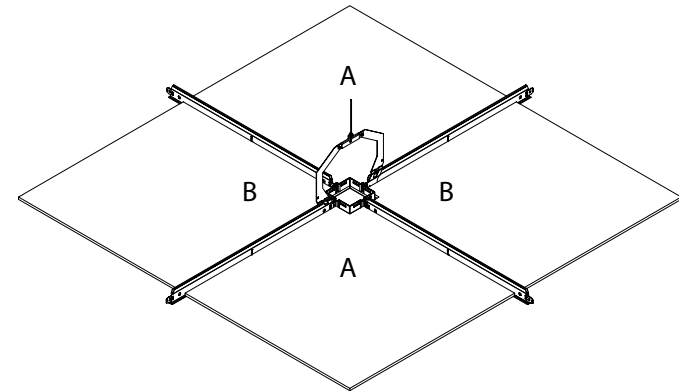

(Fig 12)

# Intersection Downlighting Assembly Sequence

STEP 1

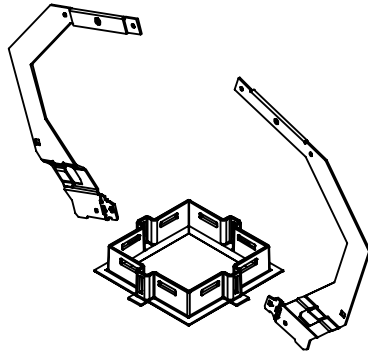

STEP 2

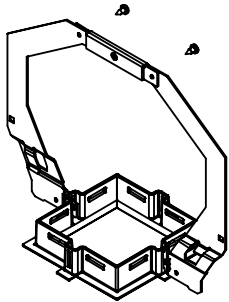

STEP 3

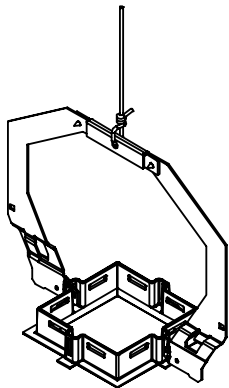

STEP 4

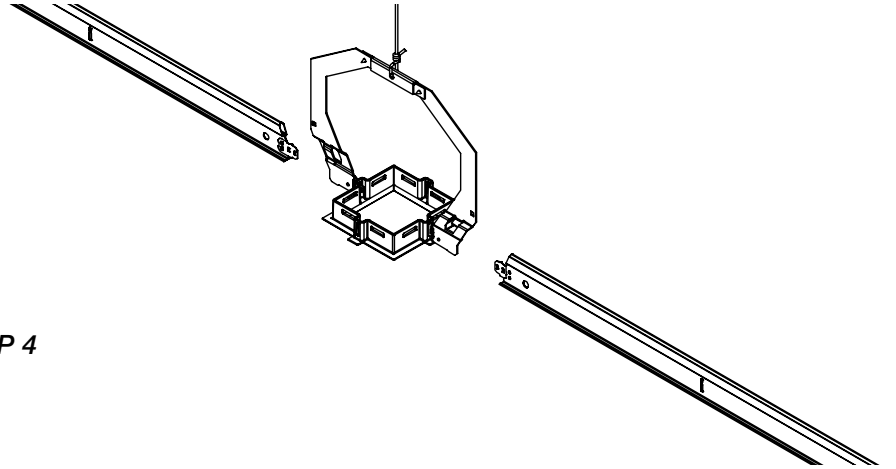

STEP 5

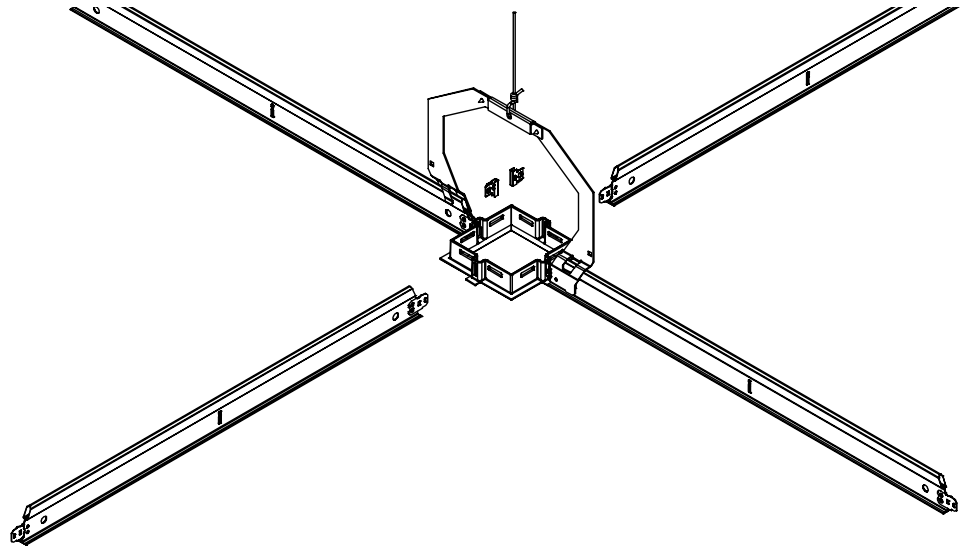

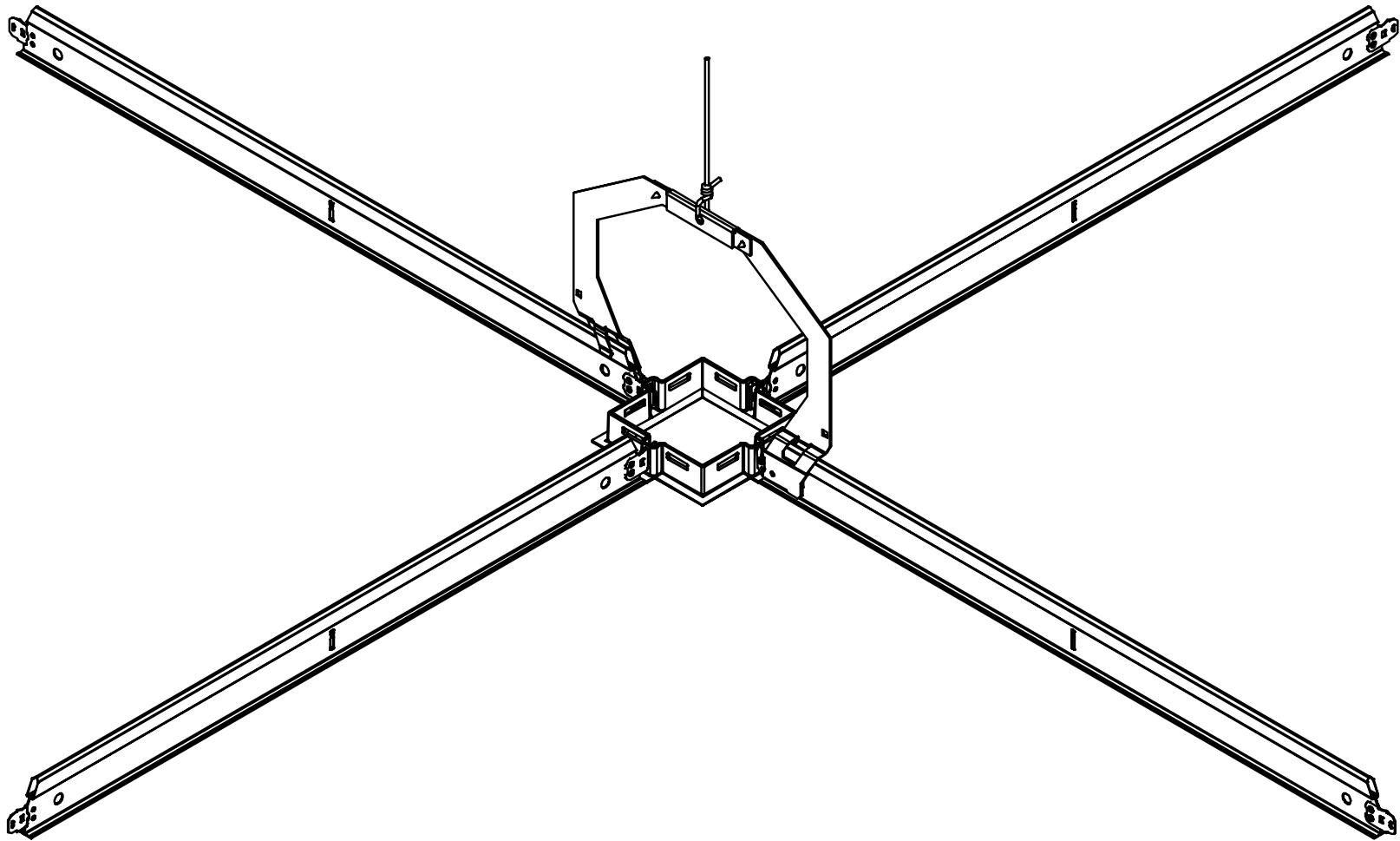

### **FINAL ASSEMBLY**

### **MORE INFORMATION**

For more information, or for an Armstrong Ceilings representative, call 1 877 276 7876.  
For complete technical information, detail drawings, CAD design assistance, installation information, and many other technical services, call TechLine customer support at 1 877 276 7876 or FAX 1 800 572 TECH.  
All trademarks used herein are the property of AWI Licensing LLC and/or its affiliates.  
© 2021 AWI Licensing Company Printed in the United States of America

**Armstrong**<sup>®</sup>  
CEILING & WALL SOLUTIONS