

METALWORKS™ Concealed

Installation Instructions

1. GENERAL

1.1 Product Description

MetalWorks Concealed ceilings consist of perforated and unperforated panels that are downward accessible, and are designed to be installed on a conventional Armstrong Prelude® 15/16" wide T-Bar suspension system with T-Bar hooks attached to panels. All panels can be removed and reinstalled for access to the plenum. Panels are supported from the suspension system by metal hooks that are screw-attached through pre-drilled holes.

Available panel sizes are 24" x 96", 24" x 120", 48" x 48", 48" x 96", and 48" x 120". Panels, hooks, and screws are sold separately.

For floating or non-continuous installations, MetalWorks Concealed 6" Trim is available.

1.1.1 Material Delivery

Panels are bulk packaged for each job.

- Natural
- T-Bar Hooks (item 5986) are packaged 50 pieces per carton.
 - 4 hooks are required for each 24" x 96", 48" x 48", and 48" x 96" panel
 - 6 hooks are required for each 24" x 120" and 48" x 120" panel
- Metal Screws (item 90190A242) are packaged 100 pieces per carton. Three screws are required for each hook.
- 12' Support Hangers (item SH12) are packaged 12 pieces per carton.
- Nominal 6" x 120" MetalWorks Concealed Trim (item 6656M1) is packaged 6 pieces per carton, and includes:
 - 30 T-Bar Connector Clips (item FXTBC)
 - 12 field splice plates (item FX4SPLICE)
 - 8 corner splice plates (item FXSPLICE)
- T-Bar Connector Clips (item FXTBC) are packaged 10 pieces per carton.
- Splice Plates (FX4SPLICE) are packaged 10 pieces per carton.
- Safety Cables (item 6091) are packaged 50 pieces per carton.

1.2 Surface Finish

All panels are constructed of and have a factory-applied powder-coated, post-production finish.

1.3. Storage and Handling

Ceiling panels shall be stored in a dry interior location and shall remain in cartons prior to installation to avoid damage. The cartons shall be stored in a vertical position. Proper care should be taken when handling to avoid damage or soiling.

NOTE: MetalWorks Concealed panels may be packaged with the face of the panel toward the outside of the carton.

Exercise care in moving and opening cartons to prevent damage to the panel face.

1.4 Site Conditions

Areas to receive ceilings shall be free of construction dust and debris. Panels should only be installed in closed and acclimatized buildings. Interior systems cannot be used in exterior applications where standing water is present or where moisture will come in direct contact with the ceiling.

1.4.1 HVAC Design & Operation

Proper design for both supply air and return air, maintenance of the HVAC filters and building interior space are essential to minimize soiling. Before starting the HVAC system, make sure supply air is properly filtered and the building interior is free of construction dust.

1.4.2 Installation Considerations

MetalWorks Concealed panels hang below the suspension system to which they are attached. The face of the installed panels will be 2-5/8" below the face of the suspension system from which they are supported. The plenum may be visible through the 1/4" panel reveal.

Not recommended for sloped ceiling installations.

2. SUSPENSION SYSTEM FOR WALL-TO-WALL INSTALLATION

2.1 General

The suspension system shall be heavy-duty 15/16" exposed tee suspension system. The installation shall, in all cases, conform to the requirements of the International Building Code and its referenced standards.

The requirements listed here represent the manufacturer's minimum acceptable installation recommendations, and may be subject to additional requirements established by the local authority having jurisdiction.

2.2 Suspension System Installation

The suspension system for this system does not line up with the panel edges. Main beams are located 1' in from the short sides of the panels and then at 2' centers. Cross tees are placed directly over the edges of the long sides of the panels. Follow these instructions carefully to complete the installation of the suspension system.

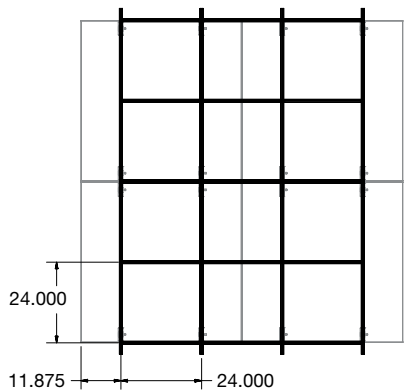

2.2.1 Wall Molding

The International Building Code requires a molding with a minimum 2" horizontal leg. However, where our ESR1308 report is accepted, a 7/8" leg may be substituted when used along with our BERC2 clip.

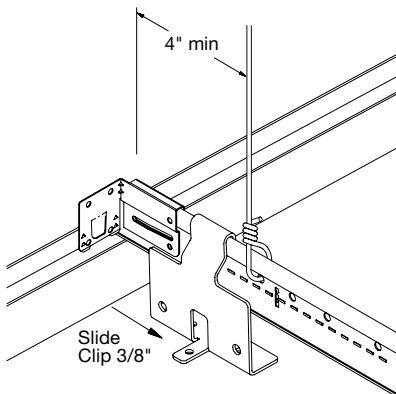

NOTE: When BERC2 is used, the clips adjacent to the molding must be relocated 3/8" toward the center of the panel. Draw lines through the factory-drilled pilot holes across the back of the panel. Shift the outer clips 3/8" toward the center of the panel and secure each with three screws.

NOTE: Perimeter wires must be attached to the terminal ends of each piece of suspension system at least 4" but not greater than 8" from the wall. These wires must be plumb within 1 in 6 (10° angle).

The 2" leg molding will provide a reveal of 1-5/8" between panel edge and wall. The reveal with a 7/8" molding will be 1/2".

Attach the desired molding to the walls 2-3/4" above the finish ceiling height.

2.2.2 Support Hanger

SH12 Support Hanger can be used to reduce the number of hanger wire attachments to main beams. If the support hanger is not used, hanger wires will be required on main beams every 4' along the main beam. Where sections of support hanger must be joined together, overlap one notch and secure with framing screws inserted through the holes provided.

2.2.3 Main Beams

Typical placement of the main beams is 1' in from the factory end of the panels and then at 2' centers. Up to 10" may be cut from the end of a panel before the suspension system location at the cut end must be altered. When more than 10" must be removed, install a main beam 1' closer to the center of the panel. Open the mouth of the support hanger notches where main beams must be installed by bending with a pair of pliers. Cut the first main beam in each row to provide a cross tee route hole at the long edge of the first row of panels. Insert the main beams into the support hanger notches and close the mouth by bending the tab back under the bulb of the main beam. Work carefully to ensure that each tab is properly seated under the bulb of the main beam.

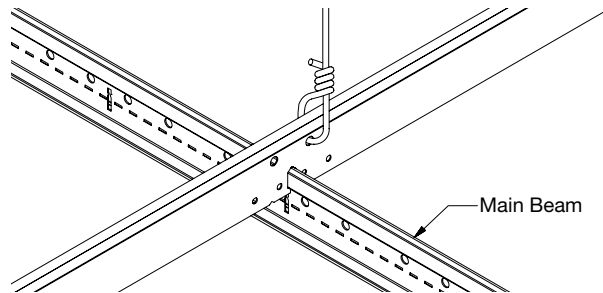

2.2.4 Cross Tees

Install 2' cross tees above the long edges of the panels to complete the suspension system installation. Swing the support hanger out of the way to provide clearance for the end details on the cross tees. Install all of the cross tees in a row and then secure the support hanger by inserting a framing screw through the hole provided and into the bulb near each end of each cross tee.

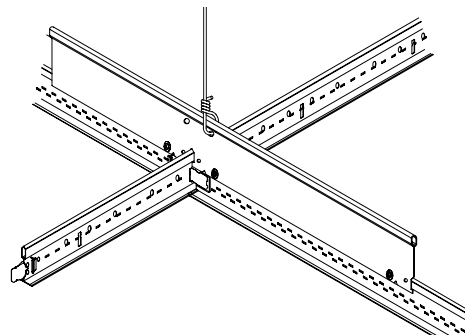

2.2.5 Perimeter Attachment

Secure the ends of the suspension system at two adjacent walls by attaching to the wall molding flange. Screws or pop rivets may be used for this connection. Use stabilizer bars or BERC2 clips to prevent the suspension system from spreading at the opposite ends.

2.2.6 Complete Seismic Installation Requirements

Install perimeter wires and lateral force bracing. Check to ensure that all code based installation requirements have been met.

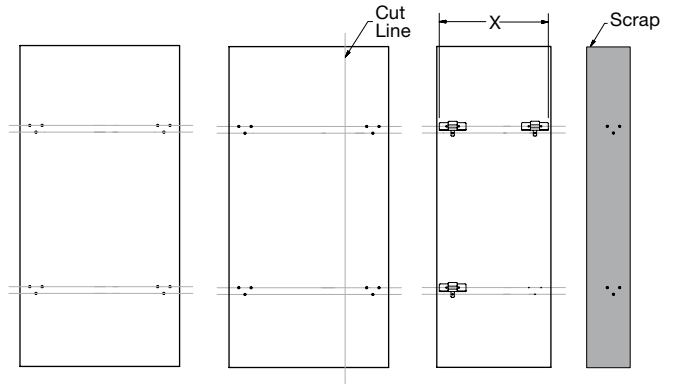

3.0 PANEL INSTALLATION

3.1 Cutting the Panels

Cut panels should never occur within the field of the ceiling. All ceiling mounted services must either replace a full panel, install into a hole that is cut into a panel, or be mounted through the face of a panel.

3.1.1 See MetalWorks™ Cutting Instructions LA-295518 for detailed information about cutting Armstrong metal ceilings. This document discusses the advantages and disadvantages of several types of equipment and how they are used when cutting our products.

3.1.2 When BioAcoustic™ (item 5823) or fiberglass (item 8200T10) infill is used, it also must be cut to size. This is best done with a large pair of shears or scissors. Reseal the poly bag with packing tape prior to installation.

3.1.3 Starting Row

Check the orientation of the hooks when attached to the pre-drilled holes on the back of the panel. The starting row must be installed such that the open side of the hooks will be facing the wall. Cut the panel as required considering the reveal dimensions listed in section 2.2.1.

3.1.4 Relocating Hooks

If cutting the panel will remove any of the hook attachment holes, these should be relocated prior to cutting.

3.1.5 Cutting the Long Edge

When the long edge of the panel is to be cut, first use a straight edge to draw lines across the back of the panel through the factory holes. Cut the panel to size. Attach a T-Bar Hook (item 5986) to each set of factory-drilled holes; three screws (item 90190A242) are required in each clip. Measure the suspension system opening and place clips on the reference lines so that the dimension from the outer edge of the factory-located clip to the outer edge of the relocated clip matches the suspension system opening dimension. Drill pilot holes at the new screw locations. Use a stop on the drill to prevent penetrating through the panel. Attach the relocated clips with three screws in each.

3.1.6 Cutting the Short Edge

Up to 10" may be cut from the narrow end of a panel without moving clip locations. When more than 10" must be removed, begin by carefully measuring back 12" from the factory holes toward the center of the panel and draw lines across the back of the panel. Cut the panel and attach the hooks to the factory holes and on the lines. Be careful to maintain the correct position along the lines. Measure the factory holes for uncut edges and follow the procedure in section 3.1.5 where the long edge has also been cut. Each clip must have three screws installed. **NOTE:** Pre-drill holes prior to installation.

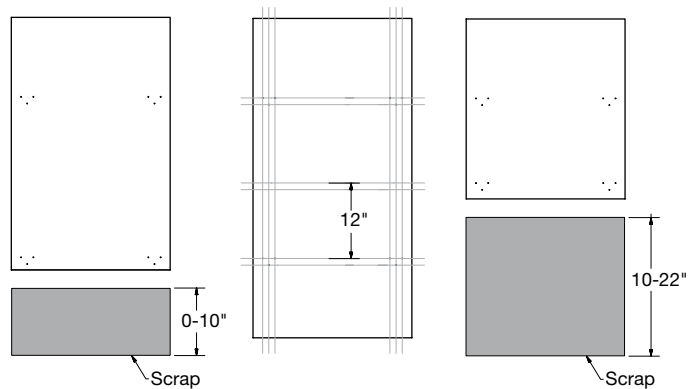

3.1.7 Attach Clips

Attach a T-Bar Hook (item 5986) at each set of factory-drilled pilot holes on each panel. Three screws (item 90190A242) are required in each clip.

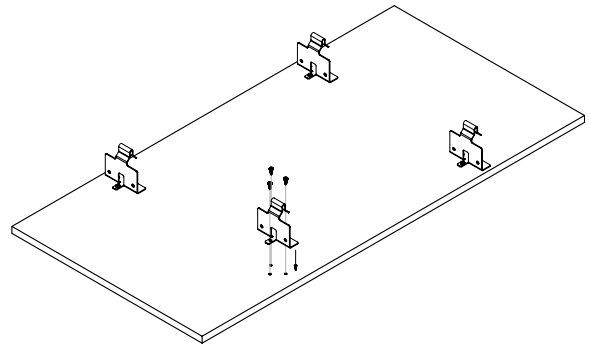

3.1.8 Treating Exposed Edges

If there is a desire to conceal the cut edge of these panels, then a Slip-on Molding (Item 7842A) can be installed. The slip-on molding needs to be cut to size to fit the cut side of the panel. If a panel has two sides that are cut, then the moldings can be mitered at the corner if desired. Relief cuts may also need to be made in the top flange of the slip-on molding as to not interfere with the T-Bar Hooks that are attached to the backside of the panel.

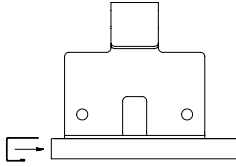

CAUTION: Cut panel edges may be sharp! Cut panel edges that are exposed to view should use perimeter trim so the interior construction of the panel can't be seen. For finishing edges on floating or non-continuous installations, see section 5 in these instructions.

3.2 Install the Panels

3.2.1 Attaching Safety Cables

Two safety cables are required for each panel and are installed at opposite corners of the panel. Loop the cable over a main beam and attach the clip end of the cable to the inside hole of the T-bar Hook. Using the hole on the T-bar Hook that is closest to the center of the panel will eliminate any interference between the clip end of the safety cable and the grid system (see figure below). Note: It is helpful to pre-hang the safety cables over the main beams at the necessary locations before lifting a panel for installation.

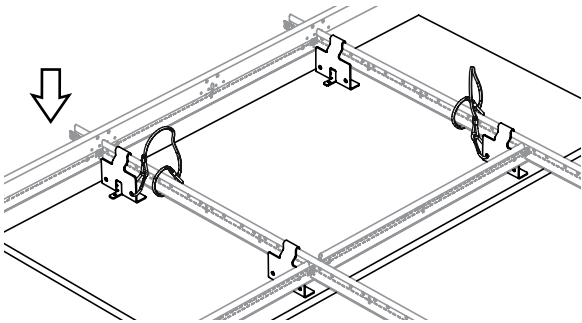

3.2.2 First Row

First row panels are installed with the open side of the clips facing the wall. Raise the hooks above the level of the suspension system and move the panel toward the wall. Lower the clips onto the bulbs of the main beams. The clips will fit between the cross tees and center the panels under the grid opening.

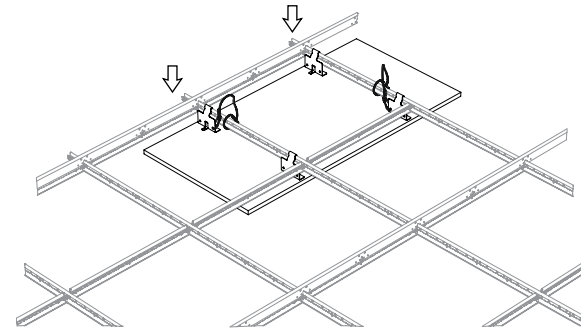
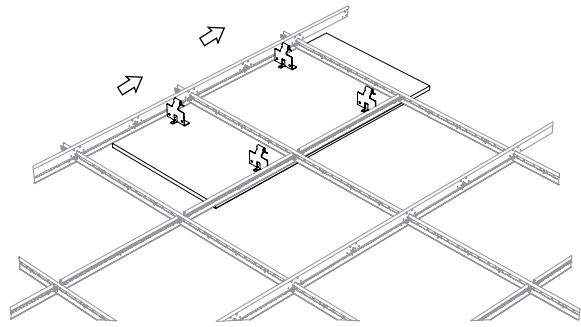
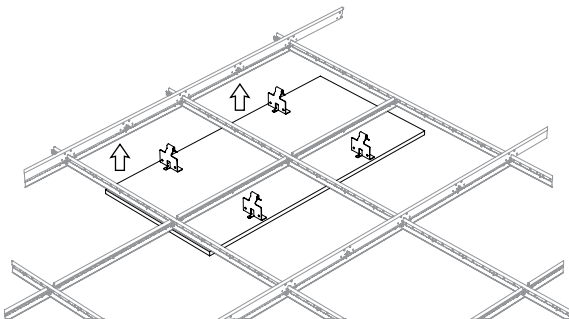

3.2.3 Middle Rows

Apply hooks to the remaining full-size panels and install in the same direction as the first row.

3.2.4 Last Row

Panels in the last row are reversed so that they install with the open side of the hooks facing the ending wall. Prepare the panels as detailed in section 3.0. Raise the factory end of the panel up and over the end of the one in the next to last row to allow the hooks to clear the suspension system. Shift the panel up and toward the wall to engage the hooks onto the main beams.

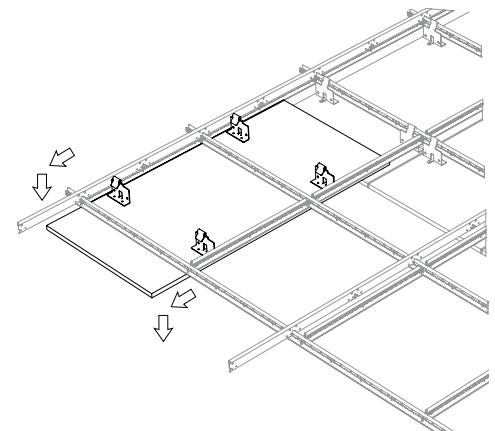
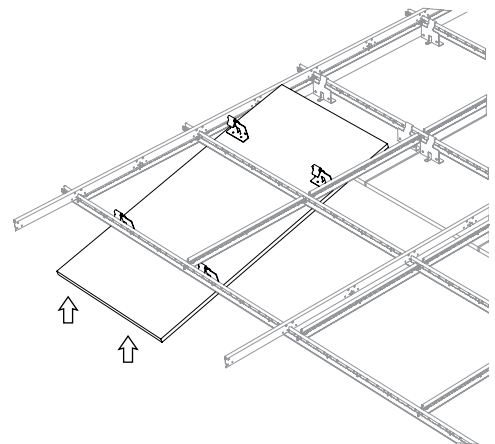

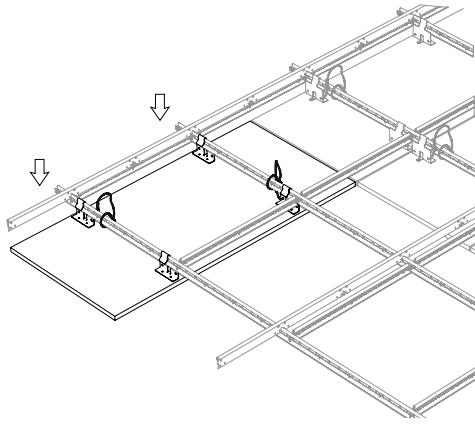

4. PANEL REMOVAL

Panels are easily removed by lifting to disengage the hooks from the main beams. Lift and shift in the long direction of the panel. Border panels will always move away from the wall. Panels in the center of the installation will only move in one direction. Once the hooks have cleared the suspension system, lower the free end of the panel until the hooks near the upper end can clear the suspension system.

5. FLOATING INSTALLATION WITH METALWORKS™ CONCEALED TRIM

A minimum 2-panel long installation is recommended for floating installations with MetalWorks Concealed Trim (item 6656M1). For installations with cut panels, please follow tips in section 3.1, 3.1.1, 3.1.5, and 3.1.6.

5.1 Pre-Assembly

Review the location of the SH12 carrying channels. They will be located 2' from the longest side of the cloud and then 4' on center (note that in some instances, this pattern will result in two SH12 carrying channels being positioned 2' from one another at the center of the cloud). Cut and splice SH12 together (if needed) to match the length of the cloud.

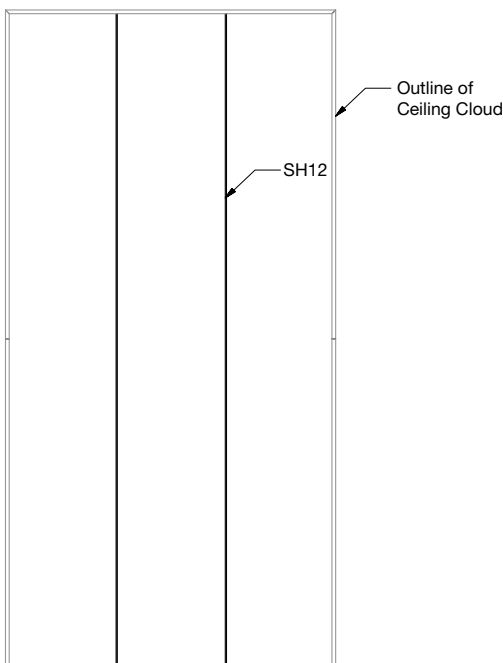

5.2 Install Main Beams

The main beams for a MetalWorks Concealed floating installation should be cut to the nominal width of the cloud.

For example, for a nominal 8' wide cloud, cut the main beams to 8' or 96". These cuts should be made through a route at both ends of the main beam. This will help to keep the right spacing for the cross tees in the system.

Install main beams into the appropriate notches on the SH12 Hanging Channels. The first main beam will be 1' from the end of the channel and the remainder will be placed at 2' centers. Slide the main beam through the notches or bend the tab on one side of the notch out of the way so that the main beam can be installed from below. Bend the tab back into position under the bulb of the main beam.

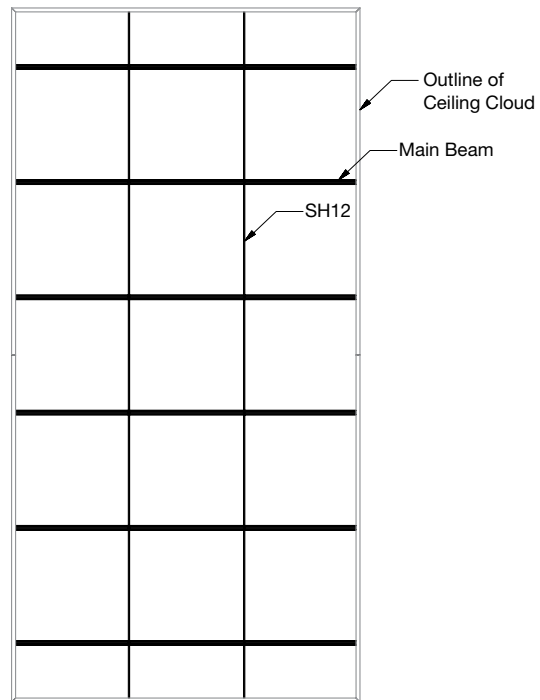
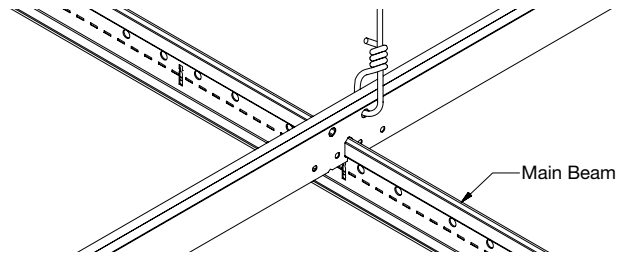

5.3 Install Cross Tees

Install 2' cross tees between main beams. After all cross tees have been installed, slide the SH12 Hanging Channel along the main beams so that it rests against the cross tees. Screw the support channel to the cross tees by inserting a #8 x 9/16" sharp point sheet metal screw into the holes on each side of the main beam as shown in the drawing below. Bend the tabs at the ends of the SH12 support channel as shown so that they will fit under the bottom of the bulb of the cross tees and secure with a #8 x 9/16" screw. Cut 1' cross tees and insert into outside main beams to match 2' cross tees. Secure with screws.

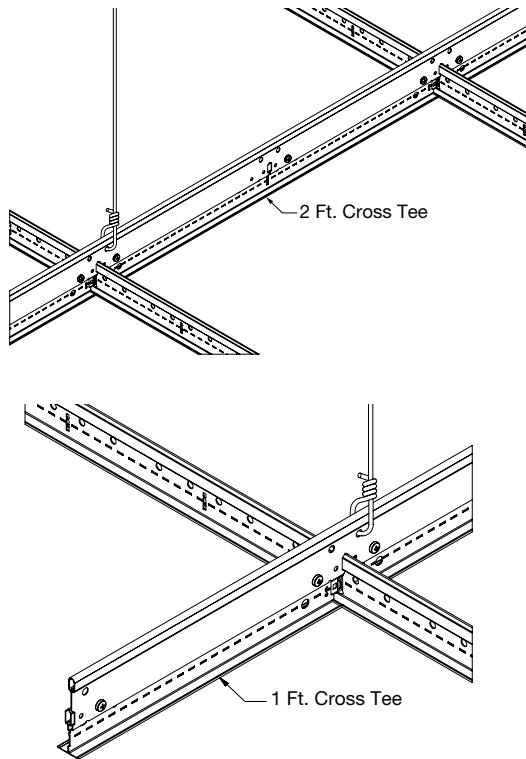

5.4 Attach Trim Clips to Main Beams and Cross Tees

Attach trim clips (item FXTBC) to the end of each main beam and cross tee by positioning as shown in the drawing. The top of the clip should touch the bottom of the bulb of the suspension system and the end of the main beam should align with the bend in the clip.

Secure each clip with two pop rivets or #8 sheet metal screws (screws are used so clips can be adjusted).

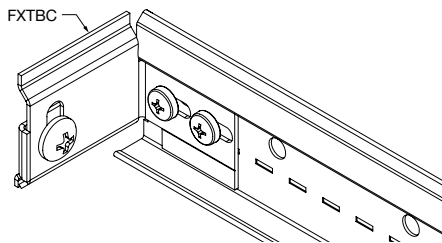

5.5 Cut and Miter Trim

MetalWorks™ Concealed Trim (item 6656M1) is available in 10' lengths with six pieces per carton. Cut trim sections and miter ends accordingly. Trim can be field-mitered using a power miter saw equipped with a blade designed to cut aluminum.

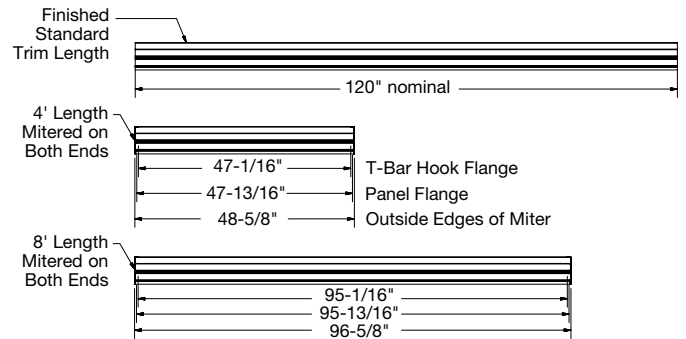
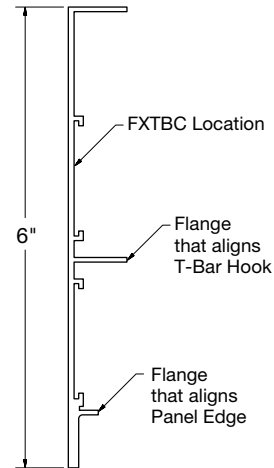

Test one piece of trim running the length of install to make sure the FXTBC clips are positioned correctly (measurement from T-Bar hook flange to cross tee should be 23-1/16" – standard 24" x 24" suspension system opening).

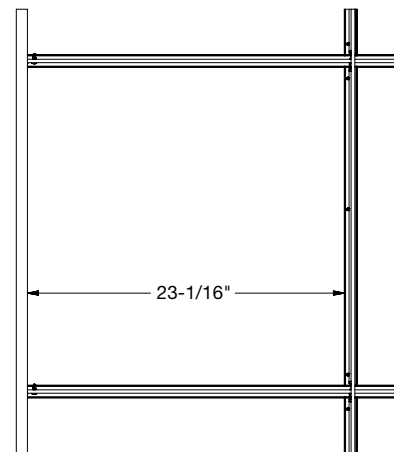

5.5.1 Attach Splice Plates to Trim

Steel splice plates (item FX4SPLICE) are used to align and secure all joints between sections of trim. Two splice plates are required at each joint. Bend the splice plate at the center notches to form the desired corner angle. Splice plates are secured to the trim sections using factory-installed setscrews. Where desired, it may be beneficial to caulk or tape the backside of the joints to prevent light transmission. To install splice plates, position the splice plate in the bosses on the inside of the trim.

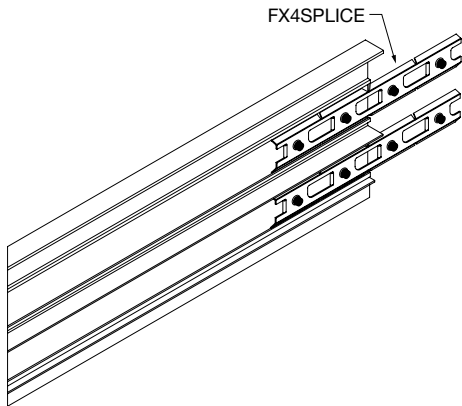
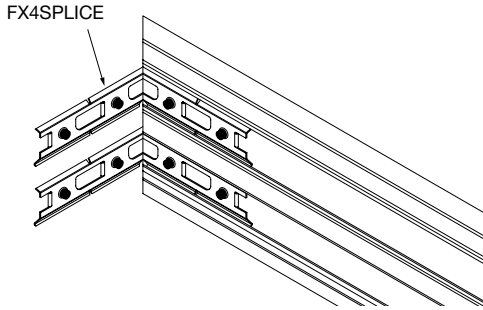

5.5.2 Install Trim

Install trim sections to main beams and cross tees by fastening FXTBC clip to trim. Make sure all main beams and cross tees stay straight and square while the trim is installed (main beam and cross tee position is critical for panel installation).

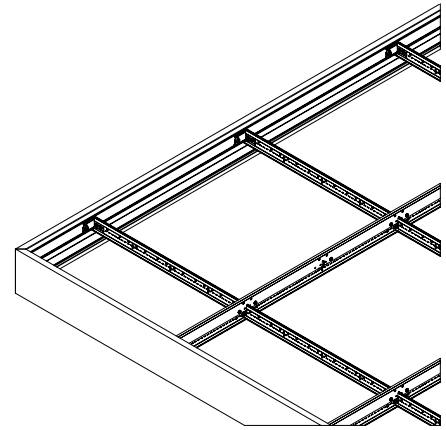
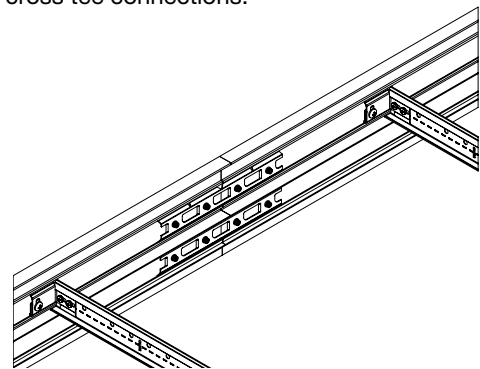
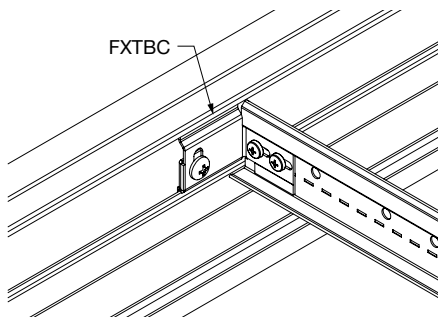

5.5.3 Corner and Straight Joint Assembly with Splice Plates

To secure each corner, position the mitered corner for correct alignment and tighten the two setscrews on the splice plate (item FX4SPLICE). Fasten the corner splice plates by starting at one corner and working around to the other three corners. Then, fasten the splice plate at the flat joints.

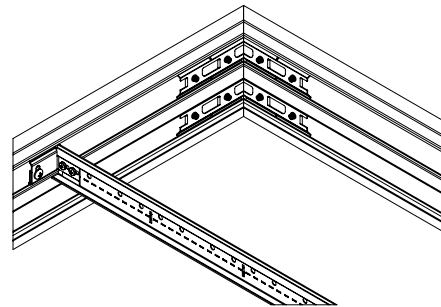

To secure splice plates for straight trim joints, pull the trim tightly together for the best fit. Use a 1/8" hex key wrench to tighten the setscrews that secure splice to trim. **CAUTION:** Do not over-tighten these screws to the point where they distort the face of the trim. When splicing straight sections of trim together, the trim joint should fall between the suspension system connections, as detailed below, so it will not interfere with the FXTBC and suspension system connection. Trim for clouds wider than 8' should be cut so the joint is located between cross tee connections.

5.6 Install the Panels

5.6.1 First Row

First row panels are installed with the open side of the clips facing the trim. Raise the hooks above the level of the suspension system and move the panel toward the wall. Lower the clips onto the bulbs of the main beams. The clips will fit between the cross tees and center the panels under the suspension system opening.

5.6.2 Middle Rows

Apply hooks to the remaining full-size panels and install in the same direction as the first row.

5.6.3 Last Row

Panels in the last row are reversed so that they install with the open side of the hooks facing the trim. Prepare the panels as detailed in section 3.0. Raise the factory end of the panel up and over the end of the one in the next to last row to allow the hooks to clear the suspension system. Shift the panel up and toward the wall to engage the hooks onto the main beams.

6. SEISMIC RESTRAINT

MetalWorks™ Concealed has been engineered for application in seismic areas. This system has been successfully tested in applications simulating seismic design categories D, E, and F. For applications in seismic zones, review the following guidelines. Check local code for the need for lateral bracing and/or compression posts/splay wires, perimeter wires, and for additional installation requirements.

MORE INFORMATION

For more information, or for an Armstrong Ceilings representative, call 1 877 276 7876.

For complete technical information, detail drawings, CAD design assistance, installation information, and many other technical services, call TechLine customer support at 1 877 276 7876 or FAX 1 800 572 TECH.

For the latest product selection and specification data, visit armstrongceilings.com/metalworks.

Inspiring Great Spaces® is a registered trademark of AFI Licensing LLC
All other trademarks used herein are the property of AWI Licensing LLC and/or its affiliates
© 2017 AWI Licensing LLC – Printed in the United States of America

BPLA-297890-817

