

METALWORKS™ Immix™ Linear System

Assembly and Installation Instructions

1. GENERAL

1.1 Product Description

The MetalWorks™ Immix™ Linear System is an aluminum ceiling system comprised of downward accessible 24" x 96" panels, available in nominal 4", 6", 8", 10", and 12" widths and 1", 2", 4", 6", and 8" depths. It is designed to install on a 15/16" Prelude® suspension system that is pre-slotted to accept the field-applied panel springs. All non-cut panels are 100% downward accessible. For the best visual, Painted Black 360° grid with black painted plenum is recommended.

MetalWorks Immix Linear panels are produced with factory-applied powder coating available in Whitelume, Silverlume, Gun Metal, as well as Sequels™ wood-look finishes including, La Jolla Oak, Cape May Cherry, Montauk Driftwood, and New Haven Walnut, and a wide range of custom colors. For acoustic solutions, panels also offer a perforated option with factory-applied acoustical fleece. Acoustic infill panels can be installed above the panels as well for added acoustics. The best aesthetics can be achieved with black Calla®, Lyra®, and BioAcoustic™ infill panels. When combining Immix Linear panels with acoustical panels, consider overall system weight for suspension system requirements. Panels are intended for interior use only. (Fig 1)

1.2 Storage and Handling

MetalWorks Immix Linear panels should be stored in a dry interior location and should remain in their original crate prior to installation to avoid damage.

IMPORTANT NOTE: Panels arrive in a crate with the hardware required for installation included, Item 7234 (panel springs). Ensure these are not misplaced during handling.

When removed for installation, the vertical panels should be stored in a flat, horizontal position. Panels could potentially scratch one another, so keep them back-to-back, and face-to-face for transporting. Proper care should be taken when handling the panels to avoid damage and soiling.

NOTE: Each panel has a clear protective film on the surface to protect it from dirt and scratching, and to indicate any directionality in the panel as noted by small arrows. The film should be removed after installation is complete. For any fingerprints which may need to be wiped clean, see Cleaning Section 1.9.

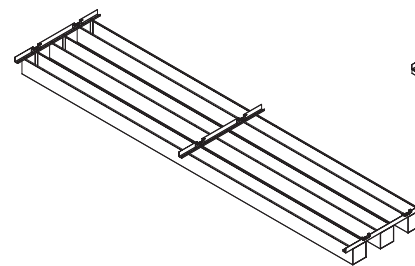

6373A44M1 Panel
4" Wide 4" Deep – 3 Planks

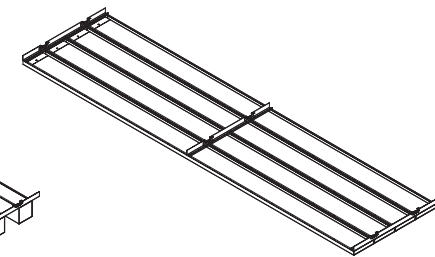

6374A61M1 Panel
6" Wide 1" Deep – 4 Planks

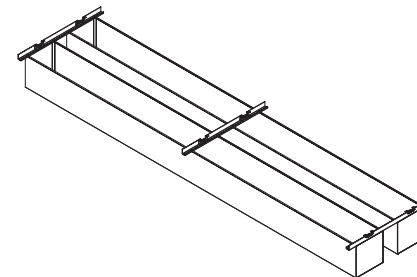

6372A88M1 Panel
8" Wide 8" Deep – 2 Planks

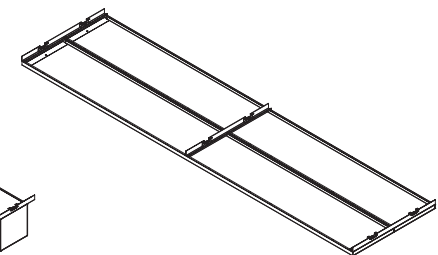

6372AC1M1 Panel
12" Wide 1" Deep – 2 Planks

(Fig 1)

1.3 Site Conditions

Areas to receive ceilings must be free of construction dust and debris. Panels should only be installed in closed and acclimatized buildings. Such installations must not be exposed to abnormal conditions, namely: chemical fumes, presence of standing water, or contact with moisture, which could result from condensation or building leaks.

NOTE: These products cannot be used in exterior applications.

1.4 Fire Performance and Sprinklers

MetalWorks™ Immix™ Linear panels have Class A fire performance based on ASTM E-84 testing. Panels may obstruct or skew the existing or planned fire sprinkler water distribution pattern, or possibly delay the activation of the fire sprinkler or fire detection system. Designers and installers are advised to consult a fire protection engineer, NFPA 13, and their local codes for guidance on the proper installation techniques where fire detection or suppression systems are present. Refer to the Percent Open Area on the panel property table found on the last page to determine if you can install sprinklers above the MetalWorks Immix Linear panels and confirm with the local code official. For panels that do not have enough spacing between planks for sprinkler integration, a hole may be cut through the plank to allow for sprinkler head and other penetrations.

1.5 Safety Considerations

Product arrives in a crate – make arrangements for safe handling. Edges of metal parts can be sharp. Handle metal carefully to avoid injury. Always wear safety glasses and cut-resistant gloves when handling or cutting metal.

When cutting planks, exposed raw edges of metal can be a safety hazard. The end cap is designed to give a finished edge appearance, however, deburring/sanding might be required based on the quality of the cut for proper fit. If a project requires special size panels, consult Architectural Specialties.

MetalWorks Immix Linear panels require at least two people to handle each panel safely, minimize damage, and provide panel support during installation. Extra safety and caution should be taken into consideration when installing these large panels.

1.6 Warranty

The MetalWorks Immix Linear System has been tested based on the installation method described in this document. Warranty will be voided if you do not follow the instructions and guidelines.

1.7 HVAC Design and Operation and Temperature and Humidity Control

Proper design for both supply air and return air, maintenance of the HVAC filters, and building interior space are essential to minimize soiling. Before starting the HVAC system, make sure supply air is properly filtered and the building interior is free of construction dust.

NOTE: Interior systems cannot be used where standing water is present or where moisture will come in direct contact with the ceiling.

1.8 Plenum

Although panels are installed from below and never travel into the plenum, MetalWorks Immix Linear panels will require a minimum 5" clearance above the suspension system. This allows enough room for the springs to travel into the plenum space during installation or removal. **NOTE:** Light fixtures and air handling systems require more space and will usually determine the minimum plenum height for the installation. It is required that MEP be independently supported. There must not be weight from any lights, diffusers, speakers, or similar devices supported by the aluminum panels or the suspension system.

1.9 Cleaning

DO NOT USE an abrasive or strong chemical detergent. A mild detergent diluted in warm water, applied with a soft cloth, rinsed, and wiped off with a chamois will maintain the panels in good condition. Oily or stubborn stains, if not removed by washing, can be wiped with products like Fantastik®, but care is necessary to avoid affecting the gloss level of the paint finish. The protective film that comes on the panels may leave a slightly sticky residue once removed. Fantastik and a microfiber cloth are effective at removing the residue.

2. DESIGN CONSIDERATIONS

2.1 Panel Properties

MetalWorks Immix Linear panels are available in a variety of standard plank heights and widths as well as custom options. Panels with 1/8" reveal between planks are not recommended to be mixed within a space. Aesthetically there could be noticeable differences if panels with different size planks are installed side-by-side. Panel ends are finished with end caps that are inserted into the planks. Because of how end caps are installed, they do not cover the exposed metal where planks were cut during manufacturing. The exposed cut metal end is more noticeable with darker finishes.

2.2 Suspension System

For a clean visual, Painted Black 360° grid with black painted plenum is recommended.

2.3 Exterior Installations

MetalWorks™ Immix™ Linear panels are not intended for exterior use.

2.4 Directionality

MetalWorks Immix Linear panels are directional. Panel length runs perpendicular to the main, with panel springs installing to main beams only.

3. ACCESSORIES

3.1 Infill Panels

Backfill the MetalWorks Immix Linear panels with mineral fiber panels to maintain accessibility, add acoustics, and hide the plenum. The best aesthetics can be achieved with 24" x 48" lay-in black Calla®, Lyra®, and BioAcoustic™ infill panels. To make removal of panels easier, infill panels may need to be trimmed in areas where repeated access is needed.

3.2 Hook Panel Removal Tool (Item 7129)

Hook Panel Removal Tool is recommended for removal of panels with 1/8" spacing between planks.

3.3 MetalWorks Immix Perimeter Cut Kit (Item 5604)

Used when projects require panels to be field-cut and field-applied support bars are needed for hanging.

3.4 MetalWorks Immix Linear Field-Cut End Caps (Item 5459 __ _M1 __ _)

Recommended to finish exposed cut panel ends on 90° straight cuts only.

4. SUSPENSION SYSTEM (WALL-TO-WALL)

The requirements listed here represent the manufacturer's minimum acceptable installation requirements established by the local authority having jurisdiction. All installations should follow ASTM C636. All references to suspension component duty ratings are per ASTM C636. Hangers and bracing are to comply with all local code requirements. The suspension system must be properly installed and leveled using not less than 12-gauge galvanized steel wire. Suspension system installation must conform to ASTM C636

requirements. The suspension system must be leveled to within 1/4" in 10' and must be square to within 1/16" in 2'. 90° alignment clips (Item M315710) can be used to ensure the grid system meets the squareness requirement.

4.1 Suspension System Layout

Prelude® XL® HD main beams that are pre-slotted 6" O.C. (Item 7301TSBL3) for MetalWorks Immix Linear panels are installed every 48" O.C. Then 48" Prelude® cross tees (Item XL7341BL3) must intersect the main beams at 90° every 48" creating a 48" x 48" module. Springs on the panel will be inserted into main beams only. Panels will run perpendicular to the main beams. *(Figs 2 & 3)*

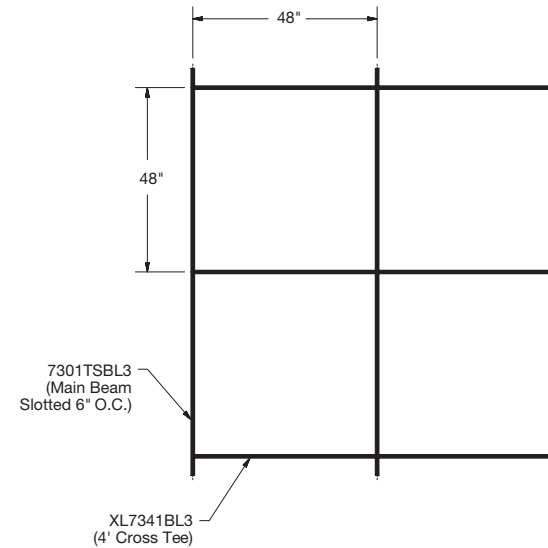

(Fig 2)

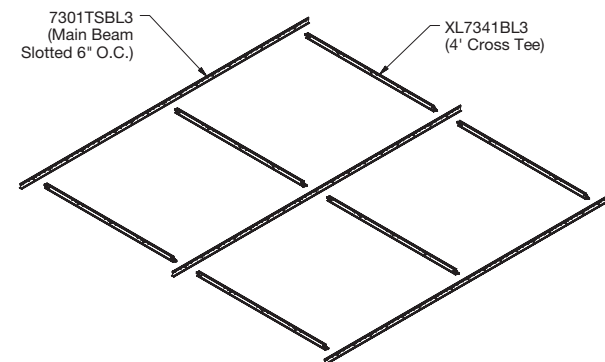

(Fig 3)

Location of the first main beam should be as detailed on the reflected ceiling plan to provide borders that are equal in size and greater than 1/2 of the full panel width. Pay close attention when cutting this first main beam to length; make sure that the slots in the main beam are in the correct position to accept the springs attached to the panel size being installed.

4.2 Perimeter Solutions (Wall-to-Wall)

Perimeter solution recommendation will be dependent upon the reveal between planks. Refer to Section 4.2.1 for panels with 1/8" reveal between planks. Refer to Section 4.2.2 for panels with planks 2" spacing or greater between planks.

4.2.1 For panels with 1/8" reveals, perimeters are trimmed with two standard wall moldings (Item 7800) at 2-1/4" apart, attached to the wall with appropriate fasteners. The suspension system will rest on the upper wall molding while the panel edges will rest on the bottom wall molding. **(Figs 4 & 5)**

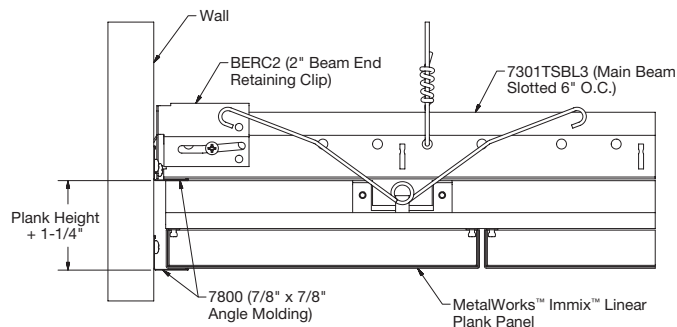

(Fig 4)

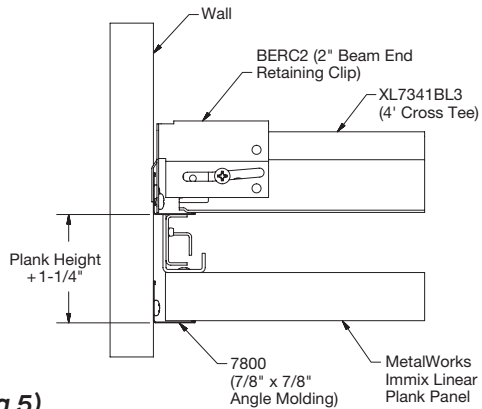

(Fig 5)

Cut panel edges can be held down against the bottom wall molding by either pop rivets or a field-cut piece of wall molding which will rest on the cut panel edge. Use the appropriate number of rivets or field-cut molding for the panel edge dimension. For the short side of the panel, a field-cut end cap is recommended to finish the cut edge. No rivets or field-cut molding is needed. Refer to Section 5.4.5 for applying field-cut end caps. **(Figs 6 & 7)**

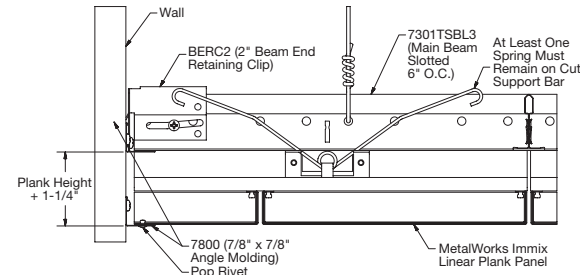

(Fig 6)

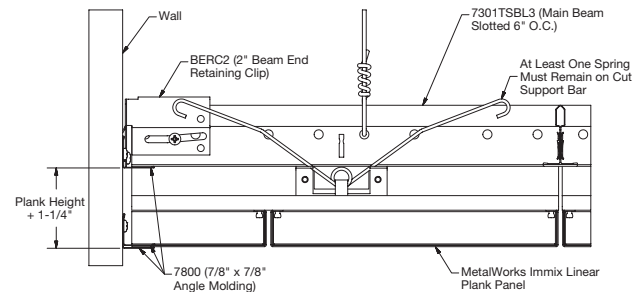
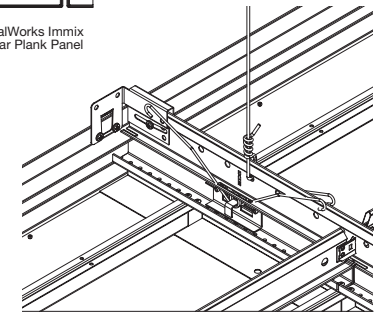

(Fig 7)

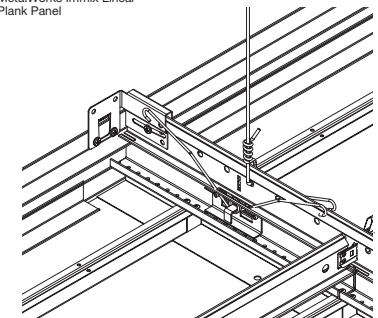

4.2.2 For panels with 2" spacing or greater between planks, the perimeter is trimmed in two ways.

Where the long side of the panel meets the wall, perimeter is trimmed with two standard wall moldings (Item 7800) at 1-1/4" apart. The suspension system will rest on the upper wall molding while the panel support bar will rest on the lower wall molding. It is recommended to have a screw within 3" from where support bar and lower molding meet, so an additional screw may be required. **(Fig 8)**

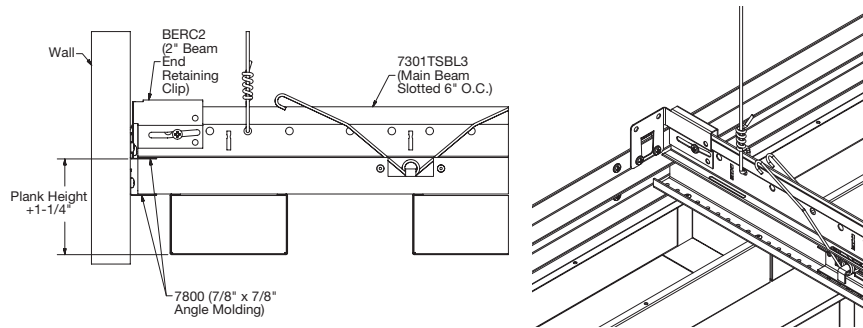

(Fig 8)

Where short panel end meets the wall, the perimeter is trimmed with a single wall molding (Item 7800). The suspension system will rest on the wall molding, and a field-cut end cap is recommended to finish the cut panel edge.

A full plank will need to be removed to address perimeter cuts on the long side of the panel. Therefore, the spacing where panel sides meet the wall is determined by the first and last plank that is installed.

Where panel ends meet the wall there should be allowance of 1" border in the ceiling. **(Fig 9)**

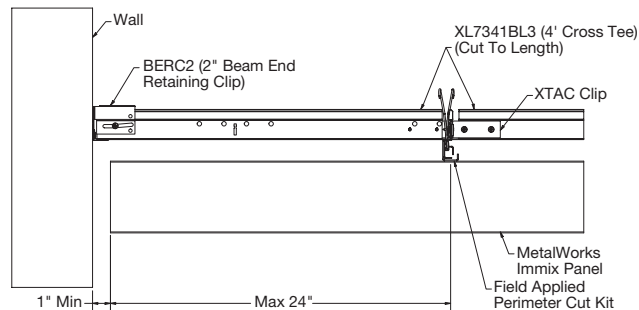

(Fig 9)

For cuts at the perimeter, see Section 5.4.4.1 for more information on how to cut the MetalWorks™ Immix™ Linear panels.

5. PANEL INSTALLATION

5.1 Panel Assembly

Springs will need to be installed on the panel bracket prior to installation. These springs (Item 7234) are included in the panel packaging. Ensure you have the number of springs required for each panel. Insert springs into each bracket following the three steps shown. **(Fig 10)**

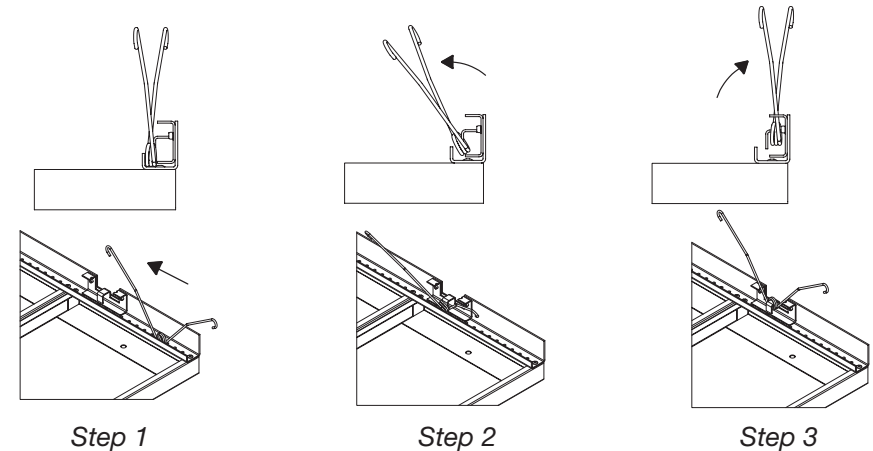

(Fig 10)

5.2 Directionality

Panels are mechanically directional; they will install perpendicular to the main. Panels have three (3) support bars with two (2) sets of springs per bar that engage the main beam and retain the panel.

5.3 Installing Panels on Suspension System

Panels will require a minimum of two people for safe installation. Align the springs with the slots in the flange of the main beam. Compress the spring and insert it into the corresponding slot. Follow this process for each spring on the panel. Then press up into place with the palm of the hand. The springs should spread apart in the slots of the grid and seat the panel into place. **(Figs 11 & 12)**

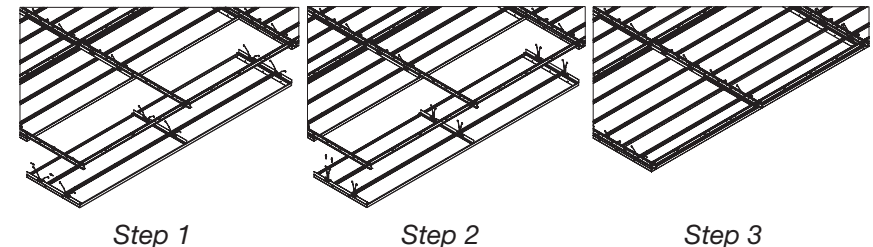

(Fig 11)

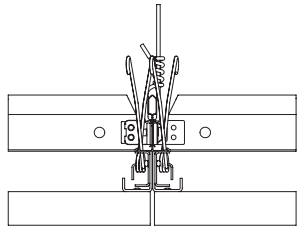

(Fig 12)

To balance the engagement of the springs on the middle main beam, it is recommended to rotate every other panel 180°. The middle support bar should be facing the opposite direction every other panel (Fig 13), allowing the springs to engage the opposite side flange of the main beam.

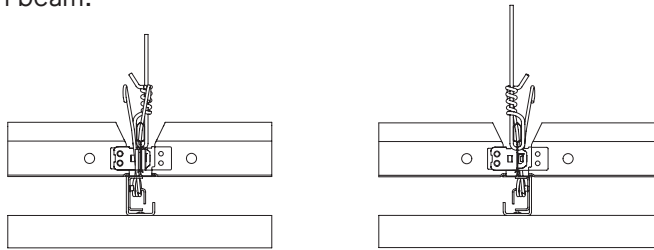

(Fig 13)

5.4 Cut Panels

5.4.1 Cut panels should never occur within the field of the ceiling. Ceiling-mounted services can be integrated with panels in three ways: **1)** if plank width allows, cut a hole into the face of a panel plank, **2)** if gap between planks is wide enough, fit services between planks without modifying panel, or **3)** remove a full plank from panel. (Figs 14 & 15) Refer to Panel Properties Table found on the last page for A and B dimensions between planks. The panel support bar should never be cut unless the cut is being made to address perimeter conditions. Refer to Section 5.4.3.

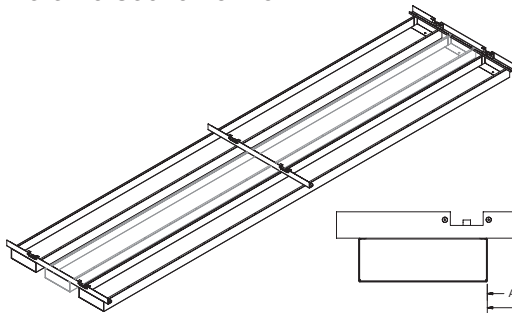

(Fig 14)

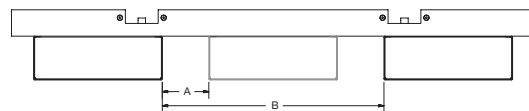

(Fig 15)

5.4.2 Cutting Guidelines

MetalWorks™ Immix™ Linear panels can be cut to size at the perimeters using standard tools and methods for metal panels. It is recommended to use a metal cutting circular saw or band saw with a new non-ferrous metal cutting blade (consult blade manufacturer for specific recommendation). For panels with deeper planks, multiple cuts may be required (front and back) or a larger blade is recommended to cut through the entire panel. Depending on the quality of the cut, the edge may also need to be filed and deburred for a clean edge. A clean edge will improve ease of installation for end caps.

5.4.3 Cutting Long Panel Side

When the long side of a panel must be cut to address perimeter conditions, the support bar should not be cut less than 12". A minimum of one spring is required per support bar along the length of the panel. (Fig 16) It is not recommended to cut the length of a plank that has depth of 2" or greater. Entire plank should be removed to address perimeter condition.

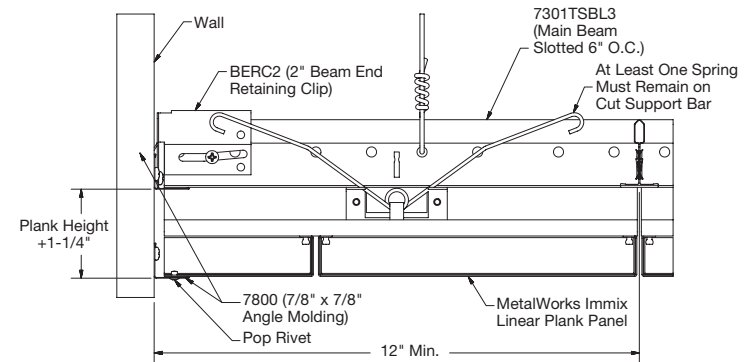

(Fig 16)

5.4.4 Cutting Short Panel End

When the short panel end requires cutting, panel cantilever/ unsupported end should not exceed 24" from remaining support bar. When cantilever exceeds 24", a perimeter cut kit (Item 5604) will be required for hanging. Refer to Section 5.4.4.1 for perimeter cut kit instructions. Additional pre-slotted main beams will be required to receive the new field-applied support bar and panel springs. Panels will require a minimum of two support bars per panel for hanging. (Figs 17 & 18)

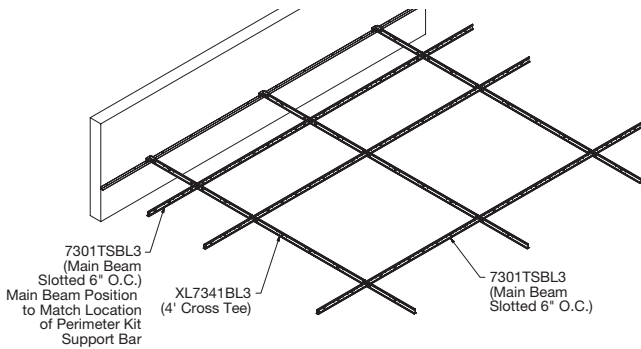

(Fig 17)

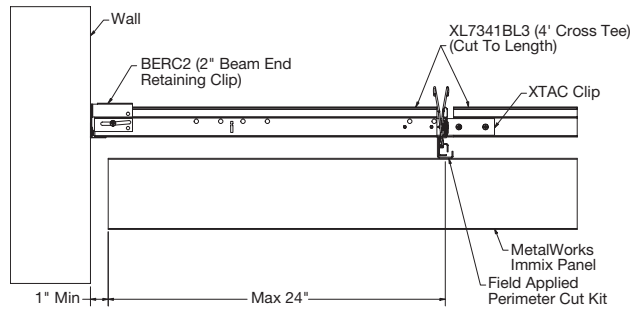

(Fig 18)

5.4.4.1 Installing Perimeter Cut Kit 5604

When a factory-applied support bar is removed, a perimeter cut kit (Item 5604) is available to install a new support bar in the field. The perimeter cut kit is required when the new cut is more than 24" from remaining factory-applied support bar. Panel planks come with factory pilot holes (spaced every 6") along the top of the planks to ease installation to the new support bar. The kit includes all the required components for assembly.

Perimeter Cut Kit Components

Ensure you have the following components prior to cutting and installing.

- 120 Aluminum Domed Head Pop Rivets (used for fastening support bar to planks)
- 40 Stainless Steel Countersunk Flat Head Pop Rivets (used for fastening the bracket torsion spring to support bar)
- 20 Torsion Spring Brackets
- 10 Support Bars

Additional Tools Required for Installation

- Rivet Gun
- Optional: An air compressor for air-powered rivet gun

Additional Accessories

- End Caps
- 3M™ Super 77™ Multipurpose Spray Adhesive (by others – to glue end cap to new cut end)

Ensure the panel is placed on a flat surface or sawhorse face down. Once cut location as been confirmed, fastening the support bar to the panel prior to cutting is recommended. Panels and support bars have pre-drilled pilot holes to ease installation.

If a panel requires multiple cuts or the new cut is too close to where the new support bar will be fastened, it is recommended to install the support bar after the cut has been made. Ensure the support bar is properly lined up to the plank pre-drilled holes prior to fastening it in place. This will ensure that correct plank spacing and dimensions on the panel are maintained.

Once you have located and matched the pre-drilled holes on the support bar and the planks, follow these four steps to assemble.

(Fig 19)

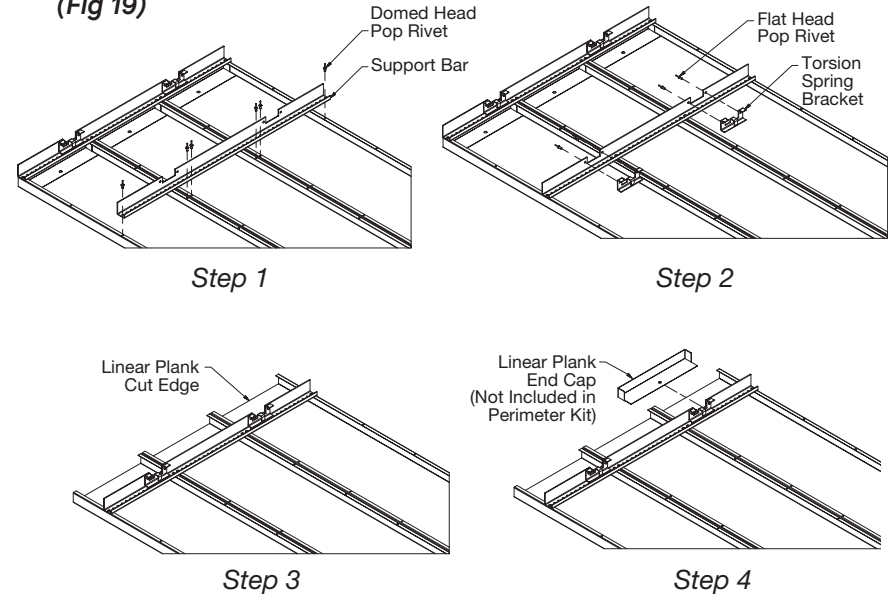

(Fig 19)

Step 1: Using the rivet gun and domed head rivets, attach the support bar to the planks. Two (2) rivets are required per plank.

Step 2: Using the rivet gun and flat head rivets, attach the torsion spring bracket to the support bar. Flat head rivets must be riveted through support bar and into torsion spring bracket so flat head is flush with support bar. Two (2) rivets are required per bracket.

Step 3: Cut panel at the desired location.

Step 4: Add field-cut end cap to the cut end. Refer to Section 5.4.5.

5.4.5 Installing Field-Cut End Caps

The field-cut end caps enable MetalWorks™ Immix™ Linear panels to be cut to length and finished on-site. Alternatively, custom length panels can be ordered with factory-applied end caps as a custom option to help expedite installation. Any field-cut ends of the panels should be finished with the field-cut end cap to ensure best visual and to aid in safe handling. (Fig 20)

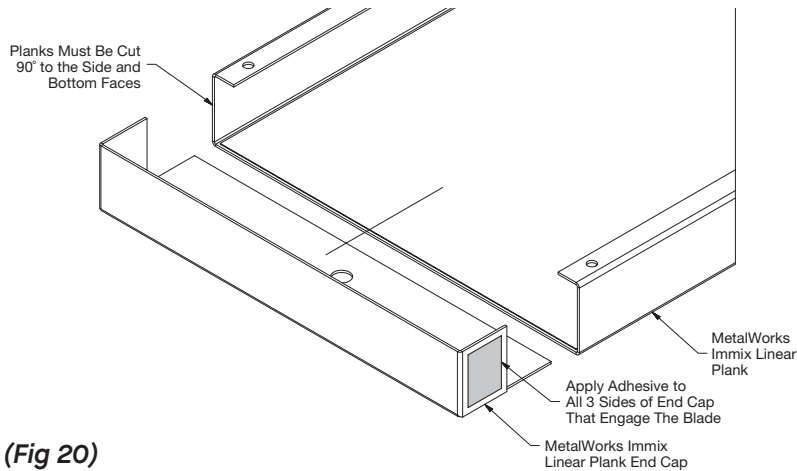

(Fig 20)

- MetalWorks Immix Linear panels can only be cut in 90° straight cuts (not mitered or angled cuts) to be compatible with the field-cut end cap.
- Field-cut end caps will require adhesive to adhere to the cut panel edge. It is recommended to use 3M™ Super 77™ Multipurpose Spray Adhesive (by others) and spray around the section of the end cap that will be inserted into the cut plank. Depending on the quality of the cut, the edge may also need to be filed and deburred for a clean edge. A clean edge will improve ease of installation for end-caps.
- Check for any excess adhesive that may have smeared outside the plank and field-cut end cap. Refer to Section 1.9 for cleaning instructions and removing excess adhesive and any sticky residue.

5.5 Panel Removal

5.5.1 All panels are removable without moving up into the plenum. While panels are downward accessible, these panels should never be allowed to swing down. When access to the plenum is needed, the entire panel should be disengaged and removed from the suspension system. It is recommended that two people handle panels for safety and to avoid damage.

5.5.2 The hook panel removal tool (Item 7129) is recommended when removing panels with 1/8" reveal between planks. The tool is inserted between two panel ends. Make sure to insert the tool within 6" from a panel intersection to grab the correct part of the panel. Twist the tool 90° to hook it to the support bar. Then pull the tool downward, slowly, until the spring catches on the flange of the grid and can be seen. Now that the spring has become accessible, push the spring together, slide it down through the slot, and pull down gently to release the panel from the main beam. (Fig 21) Adjacent panels may be removed from the same row of main beams without further use of the tool.

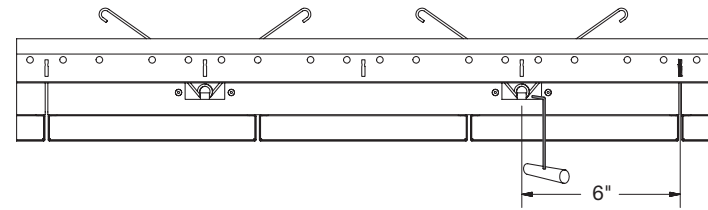

Step 1

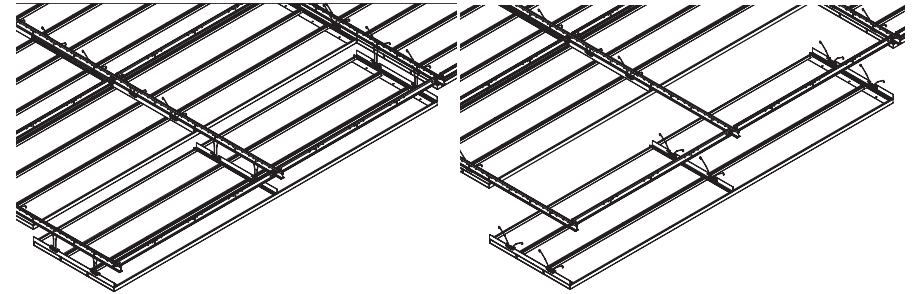

Step 2

Step 3

(Fig 21)

5.5.3 Panels with 2" reveals and greater between planks have enough space to allow the use of your hands to remove panels, so no tool is required. Wear cut-resistant gloves and hold the back of the plank within 12" from the support bar. Pull down on the panels until springs catch on the flange of the grid and can be seen. Do not press arms against the sides of the planks when removing panel, otherwise dents or other deformations may occur. Disengage all springs from all sides of the panel and remove the entire panel.

6. FLOATING PERIMETER/DISCONTINUOUS SYSTEMS

The suspension layout for floating perimeters or cloud applications should be the same as detailed in Section 4.0.

6.1 Floating Perimeter with Axiom® Trim

Please note that main beams and cross tees need to be in place around the entire perimeter so perimeter trim can be attached to the suspension system. Depending on the reveal between planks, Axiom® Classic painted Black or Painted Black 360° is recommended. A 6" trim height is the minimum height recommended and will create the best visual. The 6" height trim will help hide the suspension system and springs. For planks with 1/8" reveal that are cut at the perimeter, FXSPTHDC clips are recommended to hold down the cut edge.

(Figs 22 & 23)

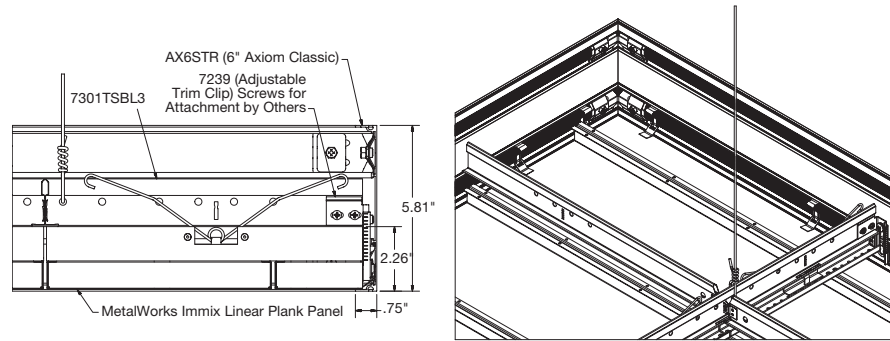

(Fig 22)

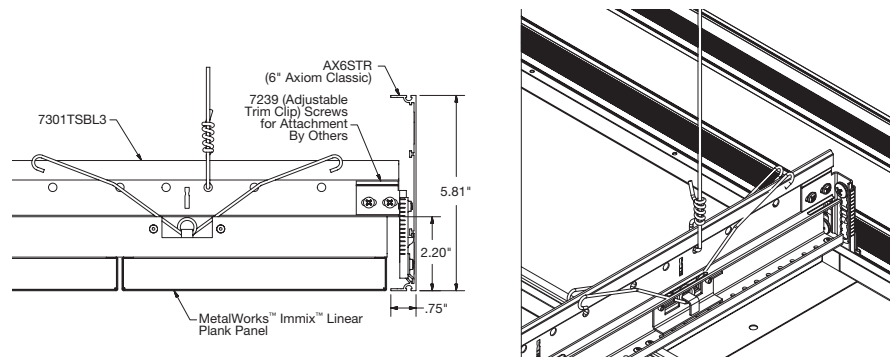

(Fig 23)

6.2 Floating Perimeter Without Trim

Floating perimeters can also be achieved without the use of a perimeter trim. Perimeter Kit (5604), end caps, and cutting the ends of the support bar may be required depending on your design, refer to Section 5.4.4.1 for installing perimeter cut kit. Panels should be supported within 24" of panel ends. (Figs 24 - Fig 26)

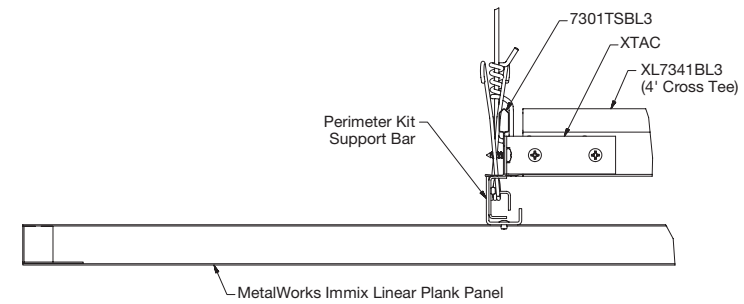

(Fig 24)

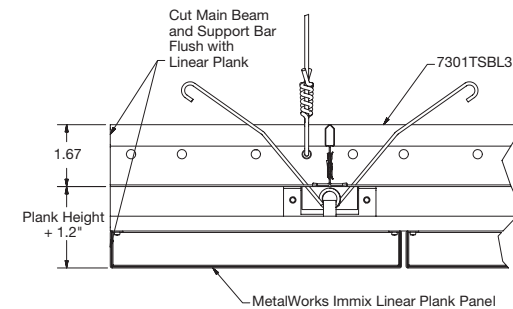

(Fig 25)

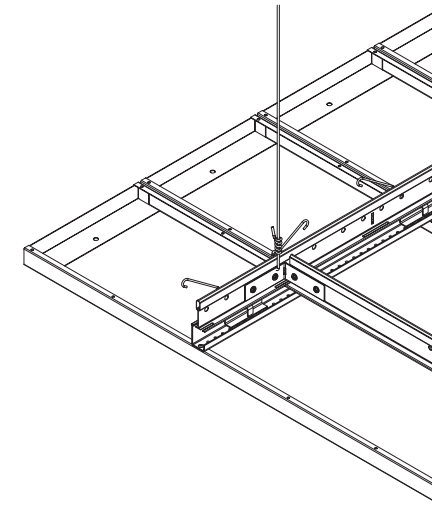

(Fig 26)

7. SEISMIC

7.1 Attachment to Grid

For more details on seismic installations please see our Seismic Design: What You Need to Know brochure.

7.2 Seismic Rx® Suspension System Cat C

- Ceiling installation should conform to basic minimums established in ASTM C636
- Minimum 7/8" wall molding
- Suspension system may be cut tight on two adjoining walls
- Minimum 3/8" clearance on two unattached walls
- BERC2 on all main beams and cross tees
- BERC2 maintains main beam and cross tee spacing; stabilizer bars not required
- Safety wires required on light fixtures
- Maximum ceiling weight of 2.5 LBS/SF

7.3 Seismic Rx Suspension System Cat D, E and F

- Ceiling installation should conform to basic minimums established in ASTM C636
- Minimum 7/8" wall molding
- Suspension system must be attached on two adjacent walls – opposite walls require BERC2 with 3/4" clearance
- BERC2 maintains main beam and cross tee spacing; no other components required
- Heavy-duty systems as identified in ICC-ESR-1308
- Safety wires required on light fixtures
- Perimeter support wires within 8"
- Ceiling areas over 1,000 SF must have horizontal restraint wire or rigid bracing
- Ceiling areas over 2,500 SF must have seismic separation joints or full height partitions
- Ceilings without rigid bracing must have 2" oversized trim rings for sprinklers and other penetrations
- Changes in ceiling plane must have positive bracing

7.4 Suspension Layouts

Suspension layouts are the same as described in Section 4.

7.5 Connection to Wall

See BPCS-4141 Seismic Design: *What You Need to Know – Code Requirements Seismic Rx Suspension System Tested Solutions – Seismic Rx Suspension System Approaches To Category C and D, E, & F Installations.*

7.6 Special Bracing Required

See BPCS-4141 Seismic Design: *What You Need to Know – Code Requirements Seismic Rx Suspension System Tested Solutions – Bracing and Restraint for Seismic Installations Seismic Separation Joints.*

See BPCS-4141 Seismic Design: *What You Need to Know – Code Requirements Seismic Rx Suspension System Tested Solutions – Seismic Separation Joints.*

SUSPENSION AND ACCESSORIES TABLE

Item No. ♦	Description	Order Separately	Required for Install	Sold by the	PCS/CTN
Suspension System					
7301TSBL3	Prelude® XL® 12' HD Main Beam – Slotted Painted Black 360°	X	Yes/Based on Design	CTN	20
XL7341BL3	Prelude XL 4' Cross Tee Painted Black 360°	X	Yes/Based on Design	CTN	60
7301TS	Prelude XL 12' HD Main Beam – Slotted	X	Yes/Based on Design	CTN	20
XL7341	Prelude XL 4' Cross Tee	X	Yes/Based on Design	CTN	60
7891	12-gauge Hanger Wire	X	Yes	Bundle	–
Perimeter Trim					
7800_ _ †	12' Angle Molding – White, Black	X	Based on Design	CTN	30
HD7801_ _	10' Angle Molding – Silver Grey, Gun Metal Grey	X	Based on Design	CTN	30
AX_STR_ _ _ *†	Axiom® Classic Straight Trim – Recommend in 6" height and up	X	Based on Design	PCS	10 LF
Accessories					
5459A41M1_ _ _ _	MetalWorks™ Immix™ Linear End Caps 4" W x 1" D	X	Based on Design	–	–
5459A42M1_ _ _ _	MetalWorks Immix Linear End Caps 4" W x 2" D	X	Based on Design	–	–
5459A44M1_ _ _ _	MetalWorks Immix Linear End Caps 4" W x 4" D	X	Based on Design	–	–
5459A61M1_ _ _ _	MetalWorks Immix Linear End Caps 6" W x 1" D	X	Based on Design	–	–
5459A62M1_ _ _ _	MetalWorks Immix Linear End Caps 6" W x 2" D	X	Based on Design	–	–
5459A64M1_ _ _ _	MetalWorks Immix Linear End Caps 6" W x 4" D	X	Based on Design	–	–
5459A66M1_ _ _ _	MetalWorks Immix Linear End Caps 6" W x 6" D	X	Based on Design	–	–
5459A81M1_ _ _ _	MetalWorks Immix Linear End Caps 8" W x 1" D	X	Based on Design	–	–
5459A82M1_ _ _ _	MetalWorks Immix Linear End Caps 8" W x 2" D	X	Based on Design	–	–
5459A84M1_ _ _ _	MetalWorks Immix Linear End Caps 8" W x 4" D	X	Based on Design	–	–
5459A86M1_ _ _ _	MetalWorks Immix Linear End Caps 8" W x 6" D	X	Based on Design	–	–
5459A88M1_ _ _ _	MetalWorks Immix Linear End Caps 8" W x 8" D	X	Based on Design	–	–
5459AA1M1_ _ _ _	MetalWorks Immix Linear End Caps 10" W x 1" D	X	Based on Design	–	–
5459AC1M1_ _ _ _	MetalWorks Immix Linear End Caps 12" W x 1" D	X	Based on Design	–	–
By others	3M™ Super 77™ Multi-Purpose Spray Adhesive	X	Based on Design	–	–
7239	Adjustable Trim Clip (ATC)	X	Based on Design	Pail	50
BERC2	2" Beam End Retaining Clip	X	Based on Design	Pail	200
5604	Perimeter Cut Kit	X	Based on Design		1
7129	Torsion Spring Hook Removal Tool	X	Based on Design		1
Infill Panels					
8373PBBK	Lyra® Square Lay-in 24" x 48" in Black Finish	X	Based on Design	CTN	6 PCS
2821BK	Calla® Square Lay-in Panel 24" x 48" in Black Finish	X	Based on Design	CTN	6 PCS
1319	Backstage Noir® Lay-in Panel 24" x 48"	X	Based on Design	CTN	6 PCS

♦ When specifying or ordering, include the appropriate 3-letter color suffix (e.g., 5459A61M1 M Y A)

* Add the 2-digit color suffix to the item number when specifying or ordering (e.g. AX6STR S Q), add an extra digit "3" before the color suffix if paint is required inside and outside of trim (e.g. AX6STR 3 S Q).

† Black is recommended for Sequels™ panel finishes

PANEL PROPERTIES TABLE

Item No. ♦	Description	Number of Planks Per Panel	Ordered Separately	Required for Install	% Open Area	Spacing Between Planks (A)	Spacing Between w/ Plank Removed (B)	LBS per SF
MetalWorks™ Immix™ Linear Panels								
6374A41_ _ _ _ _	MetalWorks Immix Linear 4" W X 1" D	4	X	Based on Design	33%	2"	8"	0.58 LBS
6376A41_ _ _ _ _	MetalWorks Immix Linear 4" W X 1" D	6	X	Based on Design	0%	0"	4"	0.82 LBS
6373A42_ _ _ _ _	MetalWorks Immix Linear 4" W X 2" D	3	X	Based on Design	50%	4"	12"	0.57 LBS
6374A42_ _ _ _ _	MetalWorks Immix Linear 4" W X 2" D	4	X	Based on Design	33%	2"	8"	0.73 LBS
6372A44_ _ _ _ _	MetalWorks Immix Linear 4" W X 4" D	2	X	Based on Design	67%	8"	20"	0.56 LBS
6373A44_ _ _ _ _	MetalWorks Immix Linear 4" W X 4" D	3	X	Based on Design	50%	4"	12"	0.80 LBS
6374A44_ _ _ _ _	MetalWorks Immix Linear 4" W X 4" D	4	X	Based on Design	33%	2"	8"	1.03 LBS
6373A61_ _ _ _ _	MetalWorks Immix Linear 6" W X 1" D	3	X	Based on Design	25%	2"	10"	0.58 LBS
6374A61_ _ _ _ _	MetalWorks Immix Linear 6" W X 1" D	4	X	Based on Design	0%	0"	6"	0.73 LBS
6373A62_ _ _ _ _	MetalWorks Immix Linear 6" W X 2" D	3	X	Based on Design	25%	2"	10"	0.69 LBS
6372A64_ _ _ _ _	MetalWorks Immix Linear 6" W X 4" D	2	X	Based on Design	50%	6"	18"	0.64 LBS
6373A64_ _ _ _ _	MetalWorks Immix Linear 6" W X 4" D	3	X	Based on Design	25%	2"	10"	0.91 LBS
6372A66_ _ _ _ _	MetalWorks Immix Linear 6" W X 6" D	2	X	Based on Design	50%	6"	18"	0.79 LBS
6372A81_ _ _ _ _	MetalWorks Immix Linear 8" W X 1" D	2	X	Based on Design	33%	4"	16"	0.49 LBS
6373A81_ _ _ _ _	MetalWorks Immix Linear 8" W X 1" D	3	X	Based on Design	0%	0"	8"	0.69 LBS
6372A82_ _ _ _ _	MetalWorks Immix Linear 8" W X 2" D	2	X	Based on Design	33%	4"	16"	0.56 LBS
6372A84_ _ _ _ _	MetalWorks Immix Linear 8" W X 4" D	2	X	Based on Design	33%	4"	16"	0.72 LBS
6372A86_ _ _ _ _	MetalWorks Immix Linear 8" W X 6" D	2	X	Based on Design	33%	4"	16"	0.87 LBS
6372A88_ _ _ _ _	MetalWorks Immix Linear 8" W X 8" D	2	X	Based on Design	33%	4"	16"	1.02 LBS
6372AA1_ _ _ _ _	MetalWorks Immix Linear 10" W X 1" D	2	X	Based on Design	17%	2"	14"	0.56 LBS
6372AC1_ _ _ _ _	MetalWorks Immix Linear 12" W X 1" D	2	X	Based on Design	0%	0"	12"	0.64 LBS

♦ When specifying or ordering, include the appropriate 6 or 7-digit perforation suffix and color suffix (e.g., 6373A44 M 1 5 W H A)

MORE INFORMATION

For more information, or for an Armstrong Ceilings representative, call 877 276-7876.

For complete technical information, detail drawings, CAD design assistance, installation information, and many other technical services, call TechLine customer support at 877 276-7876 or FAX 800 572-TECH.

Fantastik® is a registered trademark of S. C. JOHNSON & SON, INC.; 3M™ Super 77™ is a trademark of 3M.; all other trademarks used herein are the property of AWI Licensing LLC and/or its affiliates.

© 2024 AWI Licensing Company

BPLA-293243-224



Armstrong
World Industries