

METALWORKS™ Linear – Synchro™

Installation Instructions for Lighting Integration

This installation guide is a supplement to the standard MetalWorks™ Linear – Synchro™ installation instructions.

1. SOLUTION OVERVIEW

The following guidelines enable installation of various linear light fixtures with Armstrong® MetalWorks™ Linear – Synchro™ planks. The represented lighting manufacturers include Backlight and XAL®.

The installation of this ceiling and the integrated lighting solution will require coordination between the ceiling contractor and the electrical contractor. MetalWorks Linear – Synchro planks with the linear light integration is a progressive installation, meaning the lights and the ceiling panels must be installed at the same time. The general contractor should work with the electrical contractor and ceiling contractor to clearly assign responsibilities. As with all integrated construction solutions, coordination and collaboration between trades is critical for a successful and efficient installation.

There are two possible installation methods:

- Option 1: The linear light completely replaces a Linear – Synchro plank (*Fig 1*)
- Option 2: The face of the Linear – Synchro plank is cut, and the linear light is housed within (*Fig 2*)

For detailed lighting information, contact the local lighting manufacturer representative.

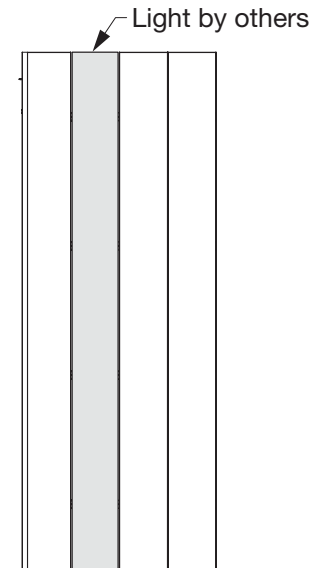

Face View – Option 1

(Fig 1)

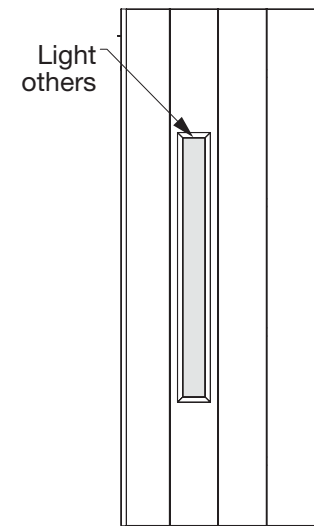

Face View – Option 2

(Fig 2)

2. COMPATIBLE LIGHTS

The following charts represent the compatible lights with the two installation methods (Fig 3).

PLANK WIDTH	CHIARO-2	CHIARO-3.25	CHIARO-5.25
BACKLIGHT OPTION #1			
2"	•		
4"	•	•	
6"	•	•	•
9"	•	•	•
11"	•	•	•
13"	•	•	•
BACKLIGHT OPTION #2			
2"			
4"			
6"	•	•	
9"	•	•	•
11"	•	•	•
13"	•	•	•

PLANK WIDTH	PANO-2	PANO-3.25	PANO-5.25
XAL® OPTION #1			
2"	•		
4"	•	•	
6"	•	•	•
9"	•	•	•
11"	•	•	•
13"	•	•	•
XAL OPTION #2			
2"			
4"			
6"	•	•	
9"	•	•	•
11"	•	•	•
13"	•	•	•

3. SYSTEM MODIFICATIONS

There are two possible installation methods to integrate a linear light into the MetalWorks™ Linear – Synchro™ system.

3.1 Linear Light Replaces MetalWorks™ Linear – Synchro™ Plank

The first installation method is replacing the MetalWorks™ Linear – Synchro™ plank with a linear light. This is achieved by entirely cutting out the number of hooks specified in the following charts based on the coordinating linear light being installed. A screw must be reinstalled connecting the carrier to the grid on both sides of the light cutout (Fig 4).

NOTE: The drywall grid main beam should not be cut – only the carrier system.

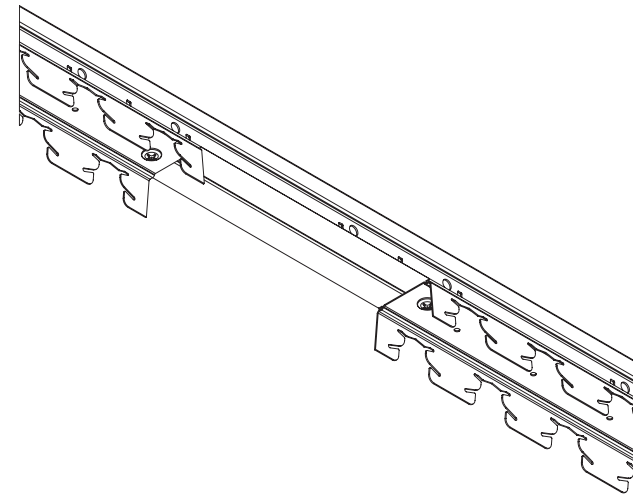

(Fig 4)

The face of the light should be flush with the face of the plank. There may be some instances where the face of the light protrudes below the face of the plank, but it should never be more than 1/8". The light must be independently supported. There will be a reveal on both sides of the light (*Fig 5*). Those reveals are listed in the following charts based on the coordinating linear light being installed. If this reveal is not acceptable, look into the second installation method.

If a remote driver is not being used, all efforts should be taken to maintain the standard grid layout of 2' x 2' modules, but grid modification may be needed if the driver interferes with the standard grid layout.

3.1.1 Backlight

Option #1	CHIARO-2	CHIARO-3.25	CHIARO-5.25
Hooks Removed	1	2	3
Equal Reveal on either side of light	0.1325"	0.6325"	0.7575"

3.1.2 XAL®

Option #1	PANO-2	PANO-3.25	PANO-5.25
Hooks Removed	1	2	3
Equal Reveal on either side of light	0.1325"	0.6325"	0.7575"

3.2 Linear Light Housed within MetalWorks™ Linear – Synchro™ Plank

The second installation method is cutting a hole in the face of the MetalWorks™ Linear – Synchro™ plank and housing the linear light within. This is achieved by entirely cutting out the number of hooks specified in the following charts based on the coordinating linear light being installed. A screw must be reinstalled connecting the carrier to the grid on both sides of the light cutout (*Fig 6*).

NOTE: The drywall grid main beam should not be cut – only the carrier system.

The face of the light should be flush with the face of the plank. There may be some instances where the face of the light protrudes below the face of the plank, but it should never be more than 1/8". The light must be independently supported. It is recommended to center the light within the face of the panel, regardless of the panel size.

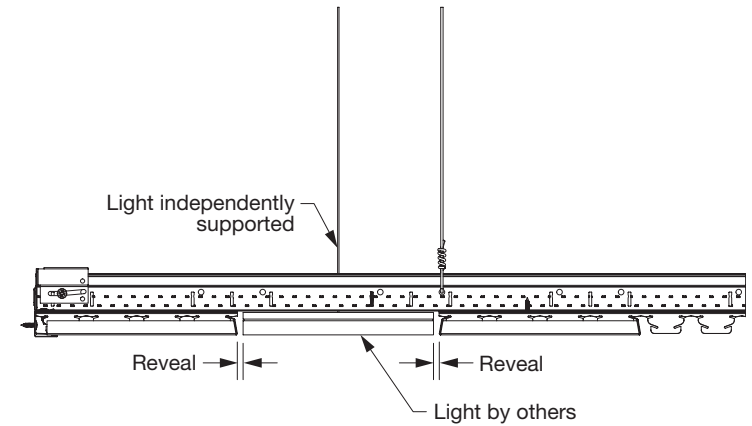

(Fig 5)

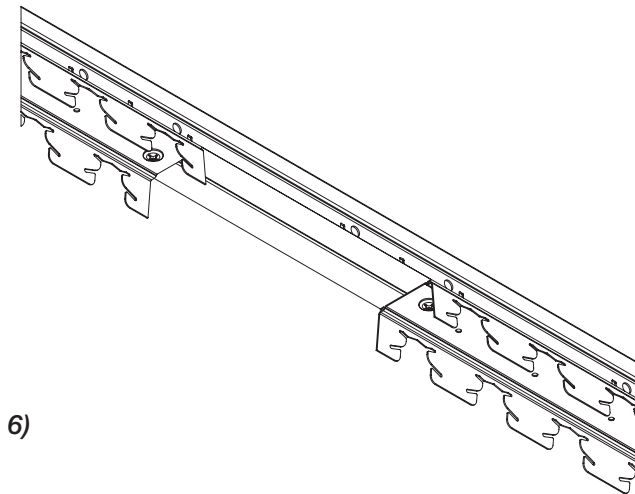

(Fig 6)

NOTE: A small portion of the hook engaging the plank may need to be removed in order to make room for the light. Never remove more than half of the hook engaging the plank (*Fig 7*).

To finish off the rough edges of the fixture opening, install Carrier Molding (item 5574) in a coordinating finish to the plank. On a flat work surface, fit the cut and mitered Carrier Molding pieces into place. To eliminate visual pop rivets, install Perimeter Pressure Springs to keep the Carrier Molding in place (*Fig 8*).

NOTE: This method is not possible with the 2" and 4" planks for most of the specified linear lights. Please refer to the charts listed in **Section 2** to determine which lights are compatible with 2" and 4" planks.

If a remote driver is not being used, all efforts should be taken to maintain the standard grid layout of 2' x 2' modules, but grid modification may be needed if the driver interferes with the standard grid layout.

3.2.1 Backlight

Option #2	CHIARO-2	CHIARO-3.25	CHIARO-5.25
Hooks Removed	1	2	3

3.2.2 XAL

Option #2	PANO-2	PANO-3.25	PANO-5.25
Hooks Removed	1	2	3

3.2.3 Cutting Recommendations

Circular Saw: recommended field cutting method for rip cuts. Use a 7-1/4" metal cutting blade for thin-walled material, such as Admiral™ (Item 62736) or equal.

CAUTION: Cut edges of metal parts can be extremely sharp. Handle metal carefully to avoid injury. Always wear safety glasses, a safety shield, and gloves when working with metal.

It may be necessary to deburr the edge for proper fit and safety if a clean cut is not achieved.

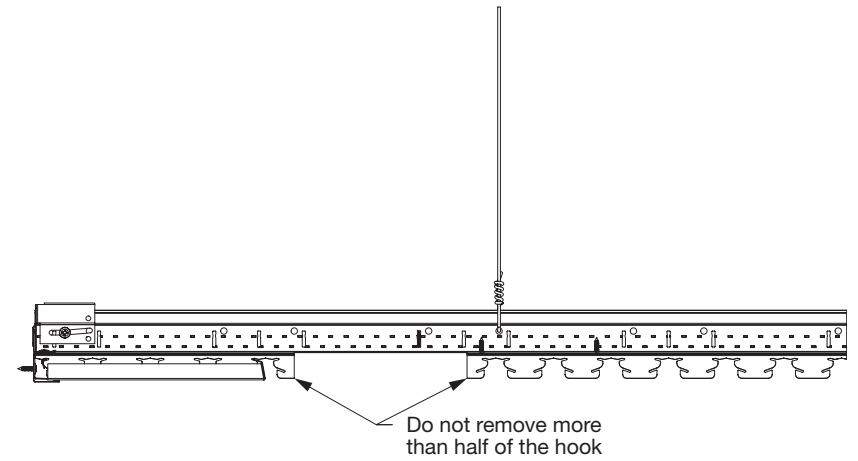

(Fig 7)

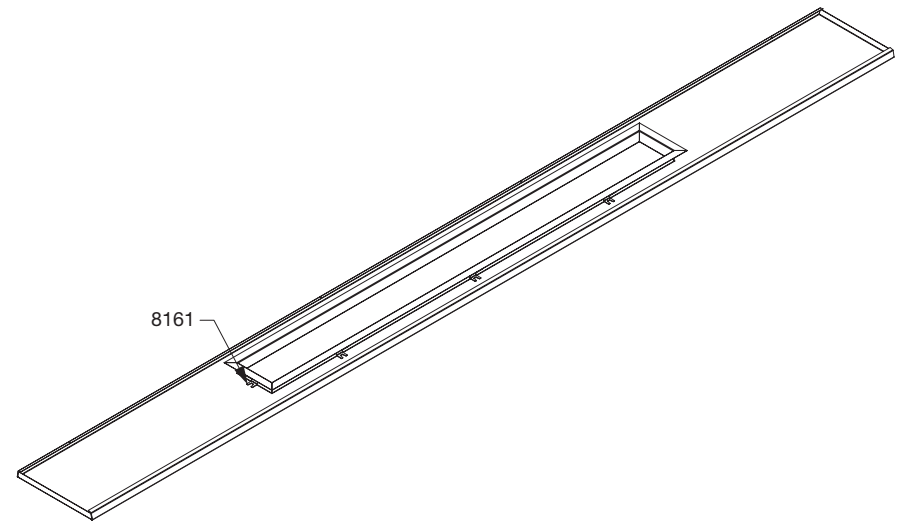

(Fig 8)

4. INSTALLATION OF THE ASSEMBLY

4.1 Linear Light Replaces MetalWorks™ Linear – Synchro™ Plank

Install the last full-size MetalWorks™ Linear – Synchro™ plank that the light will integrate next to per the standard installation instructions (*Fig 9*).

The compatible light fixture and driver should be installed by a qualified electrician in accordance with the lighting manufacturer's instructions (*Fig 10*).

Once the light has been installed, resume installation of the full-size MetalWorks Linear – Synchro planks following the standard installation instructions (*Fig 11*).

Make sure the ends of the light are level with the adjacent planks.

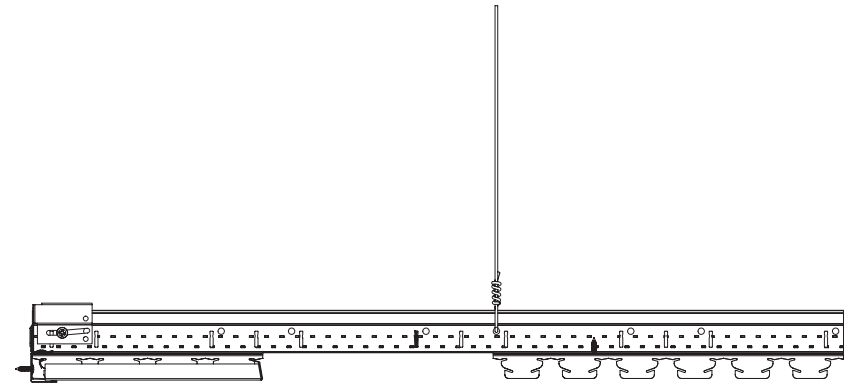

(Fig 9)

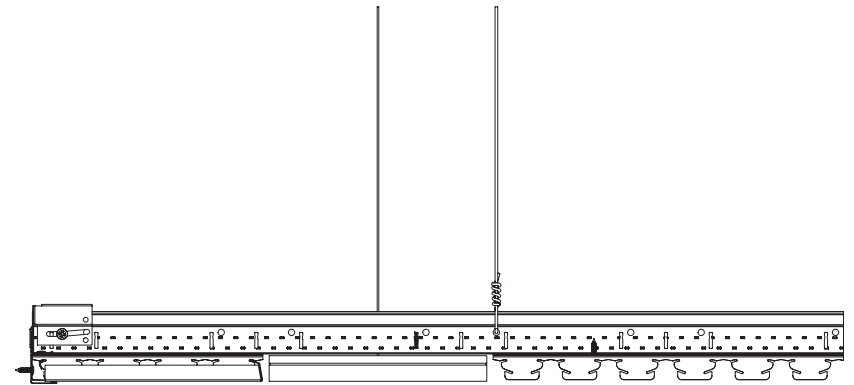

(Fig 10)

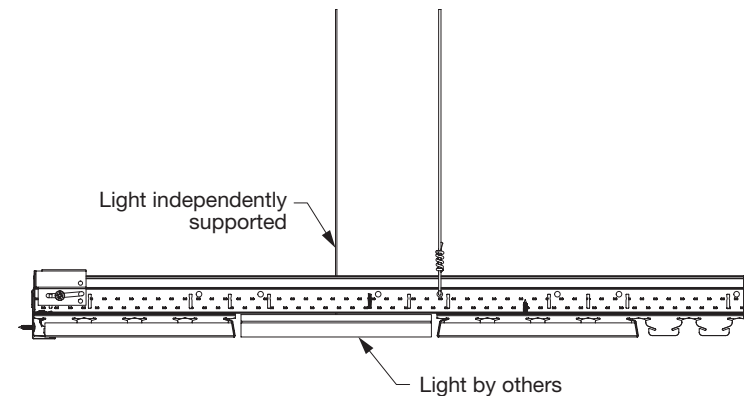

(Fig 11)

4.2 Linear Light Housed within MetalWorks™ Linear – Synchro™ Plank

Install the last full-size MetalWorks™ Linear – Synchro™ plank that the light will integrate next to per the standard installation instructions (Fig 12).

Install the MetalWorks™ Linear – Synchro™ plank that the light will integrate into per the standard installation instructions. Remember to install the Carrier Molding around the cut edge as described in section 3.2, if desired.

The compatible light fixture and driver should be installed by a qualified electrician in accordance with the lighting manufacturer's instructions (Fig 13).

Once the modified panel and light have been installed, resume installation of the full-size MetalWorks Linear – Synchro planks following the standard installation instructions (Fig 14).

Make sure the ends of the light are level with the adjacent planks.

5. SEISMIC

5.1 This system has been engineered for application in seismic areas based on the instructions listed in this document and has been successfully tested in applications simulating seismic design categories D, E, and F. Refer to the seismic section in the MetalWorks Linear – Synchro standard installation instructions for all requirements related to seismic performance for this product.

5.2 Refer to the lighting manufacturer for the specific instructions on how to install the light fixture in seismic areas.

5.3 Certain jurisdictions may have additional requirements for lighting systems. Consult your local authority for specific requirements.

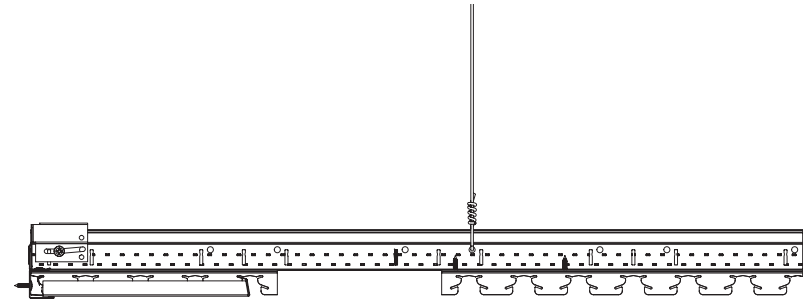

(Fig 12)

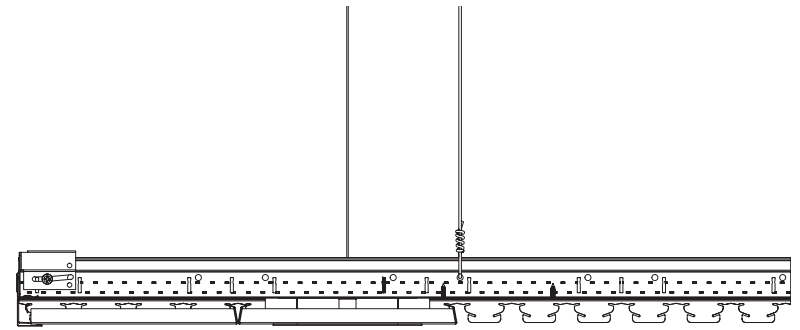

(Fig 13)

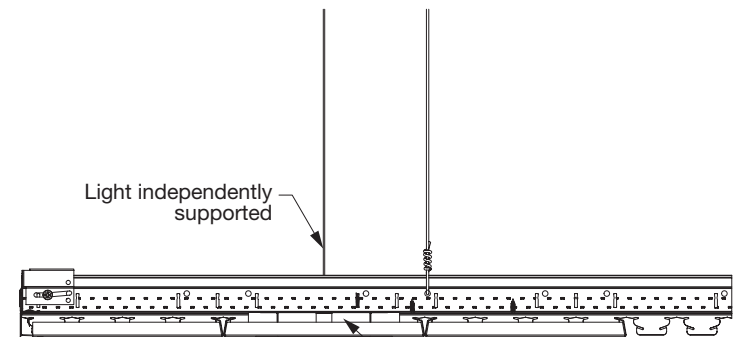

(Fig 14)

MORE INFORMATION

For more information, or for an Armstrong Ceilings representative, call 1 877 276 7876.

For complete technical information, detail drawings, CAD design assistance, installation information, and many other technical services, call TechLine customer support at 1 877 276 7876 or FAX 1 800 572 TECH.

XAL® is a registered trademark of XAL GmbH; Backlight srl is a trademark of BACKLIGHT srl; All other trademarks used herein are the property of AWI Licensing LLC and/or its affiliates.

© 2021 AWI Licensing Company Printed in the United States of America