

METALWORKS™ RH200 Custom Hook-on Panels

General Installation Instructions

1.0 GENERAL

1.1. Product Description

MetalWorks RH200 Hook-on panel system is a downward accessible, metal ceiling available in a range of sizes. It is designed to install on an Armstrong Hook-on J-Bar suspension system. All full panels can be removed and reinstalled from below to gain access to the plenum.

Two sides (typically the short sides) support the installed panels. One side will have a short hook detail that allows the panel to engage on the J-Bar suspension element and the opposite side has a long hook that will rest on top of the adjacent panel short hook. The short hook side may be easily disengaged for panel removal and plenum access. The other sides have vertical returns.

Gaskets

A foam "Gasket" is required to be installed on the hook sides and recommended for the long non-supported side separating adjacent panels. The gasket (standard width 3mm – 1/8") allows panels to be installed and removed easily and creates a uniform reveal joint. Gaskets will be indicated on the shop drawings. Field applied gasket should be installed a minimum of 1/8" above the panel face.

(See Drawing #7 on page 10)

Perforations

Panels may be perforated or non-perforated. A factory-installed acoustical fleece is typically provided on perforated panels for sound absorption. Add the optional field installed acoustical infill pad for increased sound absorption if required.

Surface Finish

Steel panels are powder-coated after forming (post-coat). Aluminum panels are painted before forming (precoated). The surface of these panels is impact-resistant, cleanable, and non-directional.

1.2. Storage and Handling

The ceiling panels shall be stored in a dry interior location and shall remain in cartons prior to installation to avoid damage. The cartons shall be stored in accordance with the instructions on the carton. Proper care should be taken when handling to avoid damage or soiling.

1.3. Site Conditions

Building areas to receive ceilings shall be free of construction dust and debris. Panels should only be installed in closed and acclimatized buildings. Interior systems cannot be used in exterior applications, where standing water is present, or where moisture will come in direct contact with the ceiling.

1.4. Plenum

Since panels are installed from below, MetalWorks RH200 Hook-on panels require minimal clearance above the suspension system.

NOTE: Light fixtures and air handling systems require more space and will usually determine the minimum plenum height for the installation.

1.5. Ceiling Panel Layout

The ceiling panel layout should have perimeter panels equal on opposite sides. The cut perimeter panels should be more than 50% of their original length and width. This will create the best visual.

2.0 SUSPENSION SYSTEM

2.1. General

The suspension system shall be Armstrong "U" profile (BPM330001) and J-Bar (BPM330014) suspension elements. The suspension system shall be properly installed and leveled using not less than 12 gauge galvanized steel wire. Suspension system installation shall conform to ASTM C636 requirements.

2.2. Suspension System – U-profile

MetalWorks Hook-on panels may be installed in a variety of modules. The U-profiles shall be spaced 48" O.C. with a maximum distance of 18" to a perimeter wall or outside edge of a floating module. The top of the U-profile is 3-5/8" above the finished ceiling height. The J-Bars shall intersect the U-profile at 90° at every module (the module is dictated by the length of the panel – consult the shop drawings). The J-Bar is connected to the U-profile with a J-Bar hanger (BPM300307). Use the Plug-in clip (BPM300120) to secure the J-Bar hanger to the U-profile at the desired module.

(See Drawings #1, #2, and #3 starting on page 4)

2.3. Suspension System – J-Bar

The J-Bar suspension system element is directional. All J-Bar hangers must be installed facing the same direction. Slide the top straight leg of the J-Bar into the hanger slot and tighten the bolt to 15 in/lbs torque. Use the J-Bar splice (BPM300343) to connect adjoining sections of J-Bar.

(See Drawing #4 on page 7)

In conditions where the panels are not cut, the J-Bar direction at the end of the panel run may be reversed. The location of the J-Bar is dictated by the panel size, and must be precisely located.

2.4. Suspension System Alignment

It's recommended the U-profiles and J-Bars be fastened to two adjacent walls using the wall anchor (BPM300140). Attach the U-profile to the wall anchor with bolts through the slot on the bottom of the U-profile. The wall anchor can be attached to the side of the U-profile only if a J-Bar connector is required at the end of the U-profile. Wall anchors are slotted to allow alignment of the suspension system for proper squareness. The J-Bars must be leveled to within 1/4" in 10' and must be square to the U-profile.

3.0 PANEL INSTALLATION & REMOVAL

3.1. General

MetalWorks Hook-on ceiling panels are easily installed and removed from below the suspension system allowing easy downward access to the plenum.

Panel Orientation

Before beginning panel installation, refer to the shop drawing for correct panel size and orientation.

3.2. Installing Panels

Note that panels have different hanging details on opposite sides. Install all full-sized panels with the hook edge oriented as shown on the shop drawings.

Foam gasket must be applied before panel installation.

- Step 1: Lay the long hook side on top of the J-Bar.
- Step 2: Raise the opposite short hook side of the panel up until it touches the bottom of the next J-Bar.
- Step 3: Gently slide the panel towards the short hook side until it will lift up over the J-Bar then slide the panel back to engage the short hook as the panel is lowered into place.

(See Drawing #10 on page 13)

Repeat process until first row of panels is in place. Subsequent rows of panels are installed similarly. Depending on panel direction, you may first have to lift the adjacent panel slightly to allow the hook of the new panel to engage. It is not necessary to use any specific sequence, as all panels are fully accessible with or without the other panels installed.

3.3. Panel Alignment

The use of a laser or string line is recommended to establish straight panel alignment. Panels may be slid along the J-Bar to adjust alignment as necessary. Mechanically secure a row of panels to the J-Bar to maintain correct alignment and prevent subsequent misalignment during routine access and replacement.

3.4. Panel Penetrations

Holes cut for sprinkler heads, light fixtures, speakers, and other services that penetrate the ceiling panel may be field or factory cut. See separate MetalWorks Cutting Instructions (LA-295518) for details.

3.5. Panel Removal

Removal is simply the reverse of installation.

- Step 1: Locate the short hook side of the panel.
 - Step 2: Lift the opposite end slightly until the flange clears the J-Bar.
 - Step 3: Lift the adjacent panel end up to clear the panel to be removed.
 - Step 4: Lower the short hook side and lift the opposite long hook side off the J-Bar.
- (See Drawing #10 on page 13)

4.0 PERIMETER DETAILS

Either the panels will all be full size or the cut edges will rest on and be concealed by some form of wall trim.

4.1 Cutting Metal Panels

▲ CAUTION: Cut edges of metal parts can be extremely sharp! Handle metal carefully to avoid injury. Always wear safety glasses and gloves when working with metal.

See MetalWorks Cutting Instructions (LA-295518) for detailed information about cutting Armstrong metal ceilings. This document discusses the advantages and disadvantages of several types of equipment and how they are used when cutting our products.

4.1.1 Cutting Perimeter Panels

Perimeter panels will have to be cut and fit as needed. Carefully measure the perimeter opening and transfer this dimension to the panel. Cut the metal ceiling panel to fit the specified wall trim option. Install the panel and secure the cut edge on the perimeter molding as indicated on the shop drawing.

(See Drawing #7 on page 10)

4.1.2 Aluminum F-Molding Wall Trim Option

Use F-molding Wall Angle (BPM330003) or F-molding Shadow Wall Angle (BPM330011) around the perimeter. Molding must be securely fastened to the wall every 16" to 24". The cut edge of the MetalWorks panel will rest on the horizontal flange. Insert the pressure spring (BPM311081) into the channel to keep the cut edge tight on the wall molding.

Use the Shadow F-molding to create a reveal between the wall and molding.

(See Drawing #8 on page 11)

Insert the corner element (BPM331082) into the channel for proper F-molding alignment for both inside and outside mitered corners.

(See Drawing #7 on page 10)

4.1.3 Channel Molding Wall Trim Option

Use Armstrong Channel Molding #7835 around the perimeter. Molding must be securely fastened to the wall every 16" to 24". The cut edge of the MetalWorks panel will rest on the bottom horizontal flange. Insert a #7835SC spreader channel to keep the cut edge tight on the wall molding.

(See Drawing #9 on page 12)

4.2 Full Panel Modules

4.2.1 Perimeter Clearance

Full module panel installation requires a minimum of 1/2" clearance between the panel and the perimeter wall. Refer to the shop drawing for specific details.

4.2.2 Confirm Layout

For proper fit of the full panel module installation, you must verify that site dimensions are exactly as specified on the shop drawings.

4.2.3 Full Panel Module Perimeters

Full panel module installations typically require both end J-Bars to face outwards. This also requires both end MetalWorks™ panels have the short hook end facing outwards. This is true whether the panels are installed next to a perimeter wall or floating within the room. Refer to the shop drawing for installation layout, panel orientation, and perimeter detail specifications.

Standard angle wall molding can be installed slightly above the bottom of the end J-Bar to conceal the suspension system from the line of sight.

(See Drawing #9 on page 12)

5.0 SEISMIC INSTALLATIONS

5.1 Seismic Design Category

The following recommendations are solutions to meet installation requirements in areas of severe seismic activity (IBC – C, D, E, and F). The local authority having jurisdiction must approve all seismic installation details before installation begins.

5.2 MetalWorks RH200 Suspension System

The U-profiles and J-Bars are the suspension system for MetalWorks RH200 panels. This system must be attached to the perimeter walls on two adjacent sides. The opposite walls must have 3/4" clearance.

5.2.1 U-profile

The U-profile end must be positively attached to one perimeter wall. Attach the wall anchor to the perimeter wall with fasteners as required. Attach the U-profile to the wall anchor with bolts through the slot on the bottom of the U-profile. Wall anchor can be attached to the side of the U-profile only if a J-Bar connector is required at the end of the U-profile.

(See Drawing #12 on page 15)

5.2.2 J-Bar

The J-Bar end must be positively attached to one perimeter wall using the wall anchor. Attach the wall anchor to the perimeter wall with fasteners as required. Use self-drilling sheet metal screws to secure the J-Bar to the wall anchor. Wall anchor can be attached to the top or side of the J-Bar. Splice adjoining J-Bars with the top section of the J-Bar splice plate and four self-drilling sheet metal screws.

(See Drawing #12 on page 15)

5.2.3 SYSTEM RESTRAINTS

5.2.3.1 Splay Bracing

Typical system restraints are the 4-wire cluster splay bracing and compression post. This must be made at an intersection of the U-profile and J-Bar. Fasten the compression post to the U-profile with #10 self-drilling sheet metal screws or equivalent. Refer to the local authority for system restraint requirements.

(See Drawing #11 on page 14 for typical splay bracing and compression post installation)

5.2.3.2 Rigid Bracing

Installations not anchored to the perimeter walls or floating clouds require rigid bracing to structure strong enough to resist lateral forces imposed upon it without damaging the system or allowing panels to fall from the ceiling.

5.2.4 Full Panels

It is recommended that a full row of MetalWorks RH200 panels be securely fastened to the J-Bar. Use self-drilling sheet metal screws through the panel hook into the J-Bar. Depending on panel width and ceiling accessibility, secure a row of panels every 8 to 12 feet to aid in panel alignment and system integrity.

(See Drawing #11 on page 14)

5.2.4.1 MetalWorks Seismic Clip

All RH200 hook-on panels that are not secured to the J-Bar must have two MetalWorks seismic clips (BP6130) installed to maintain secure engagement on the J-Bar. The MetalWorks seismic clip easily installs onto the J-Bar before panel installation. (See instructions included with Metalworks seismic clips.)

(See Drawings #11 and #12 on pages 14 and 15)

5.2.4.2 Installing Panels

The MetalWorks seismic clip will not interfere with panel installation. See step 3.2 of the standard Installation Instructions. The RH200 panel hook will lift the seismic clip ends as the panel is installed. The MetalWorks seismic clip provides positive tension on the RH200 panel hook.

5.2.4.3 Panel Removal

The MetalWorks seismic clip tension does require more care for panel removal. Follow step 3.5 of the standard installation instructions. Use two people to remove a panel with MetalWorks seismic clip. One will raise the adjacent panel end evenly and only high enough to clear the panel hook. The other person can now evenly raise their panel ends to disengage the hook for the J-Bar and slide the panel off the suspension system.

5.2.5 Cut Perimeter Panels

Perimeter panels that require field cutting to fit on a wall trim option must have a minimum of 5/8" edge resting on the horizontal surface of the wall trim. All perimeter panel hook ends must have two MetalWorks seismic clips to maintain secure engagement on the J-Bar.

(See Drawings #12 and #13 on pages 15 and 16)

5.2.6 Full Panel Perimeters

Full panel perimeter installation, either within 1/2" of a wall or a floating cloud, require the short hook end detail and an outward facing J-Bar installation. If the MetalWorks seismic clip cannot be installed due to panel end interference or an unacceptable visual, use optional BP6036 seismic hold down clip (CURLY CLIP). This clip is fastened to the top of the J-Bar with a self-drilling sheet metal screw. It provides tension on the inside of the panel to keep the panel hook engaged on the J-Bar.

(See Drawing #13 on page 16)

6.0 Exterior Applications

MetalWorks RH200 panels can be used in exterior applications. For more information, contact Architectural Specialties at 1 877 276 7876, select options 1-1-4.

RH200 Hook-On Panel Suspension Installation

U-profiles are installed 48" on center with a maximum distance of 18" to the perimeter walls.

U-profiles are suspended with a 12 gauge galvanized wire, wires must be within 18" of the perimeter wall, then 48" on center.

Hanger wire must be wrapped tightly with 3 full wraps within 3" of the U-profile.

Level U-profile to within 1/4" in 10' feet (ASTM C636). U-profile will be 3-3/4" above the finished ceiling height.

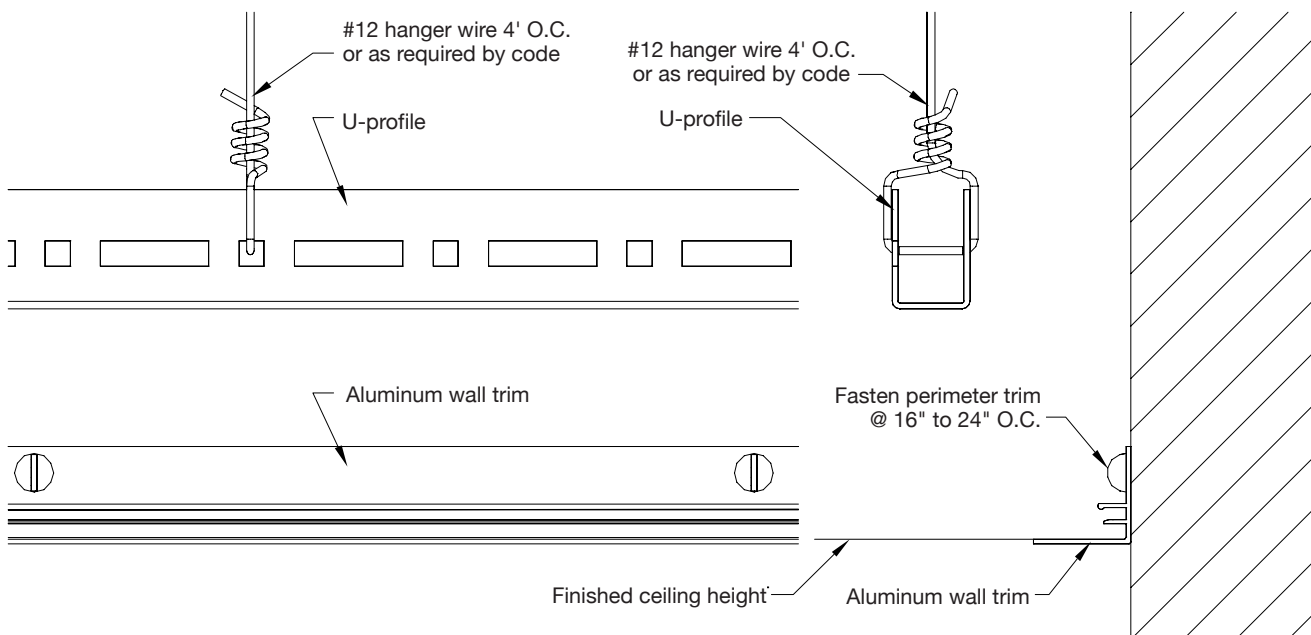
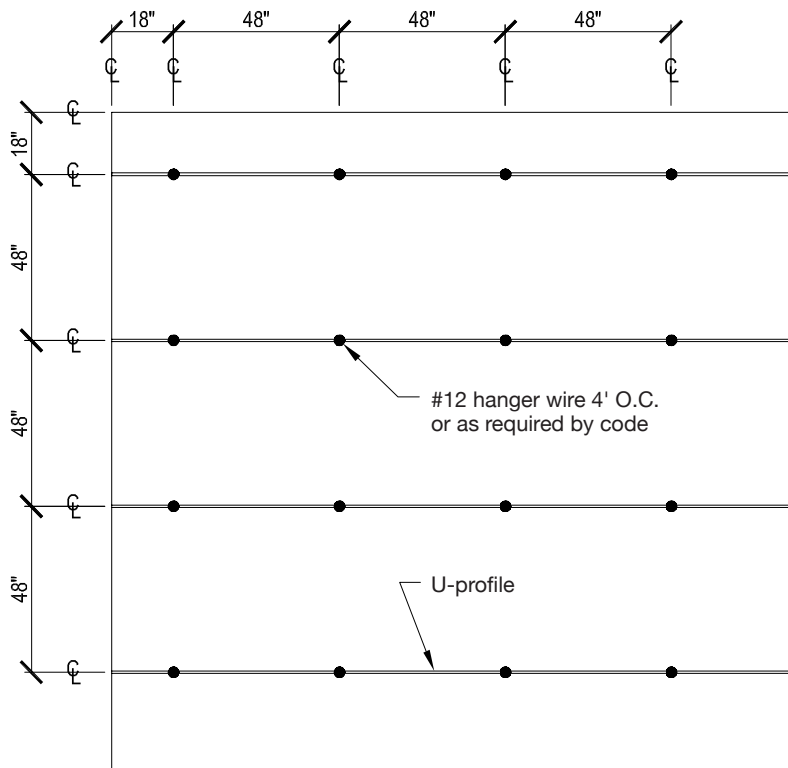

Drawing 1

SPLICING U-PROFILE AND ATTACHING TO THE PERIMETER WALL

Use the profile splice to join sections of U-profile. Use two bolts and four plug-in clips to maintain module control.

Use a wall anchor to fasten the U-profile to the perimeter wall. Securely attach the wall anchor to the wall and bolt it to the bottom of the U-profile.

The wall anchor is slotted to allow alignment of the U-profile. The square punched holes must be aligned straight for the 1" / 2" moduled control.

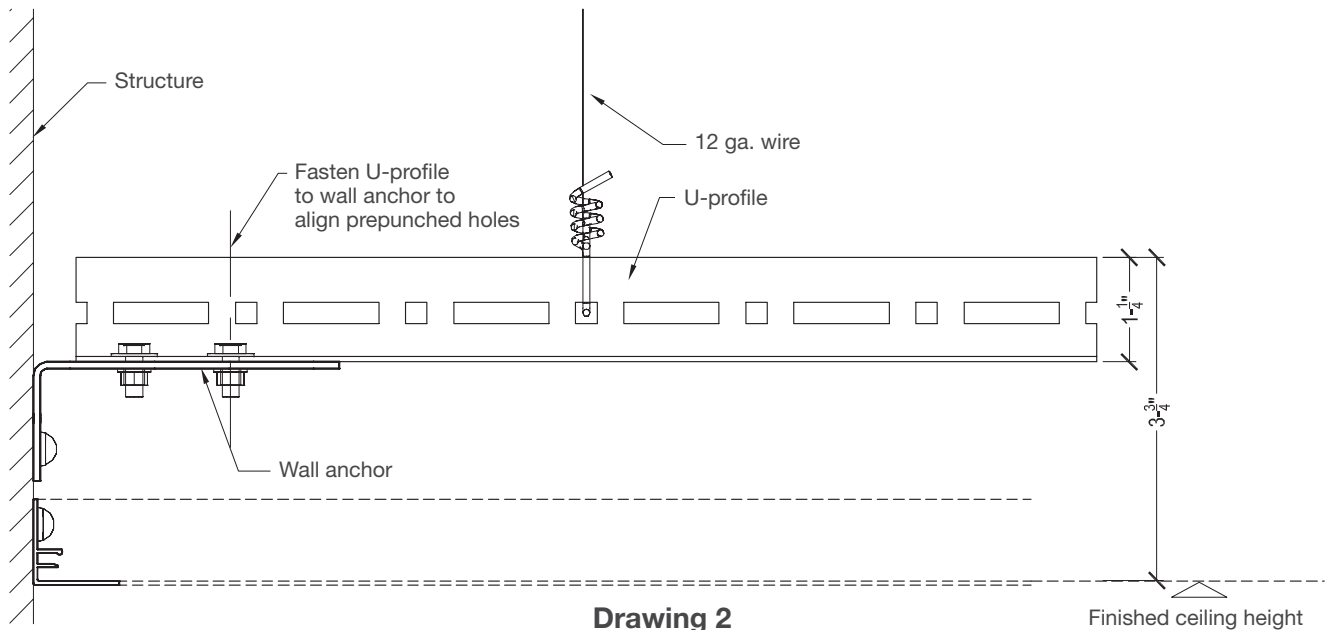
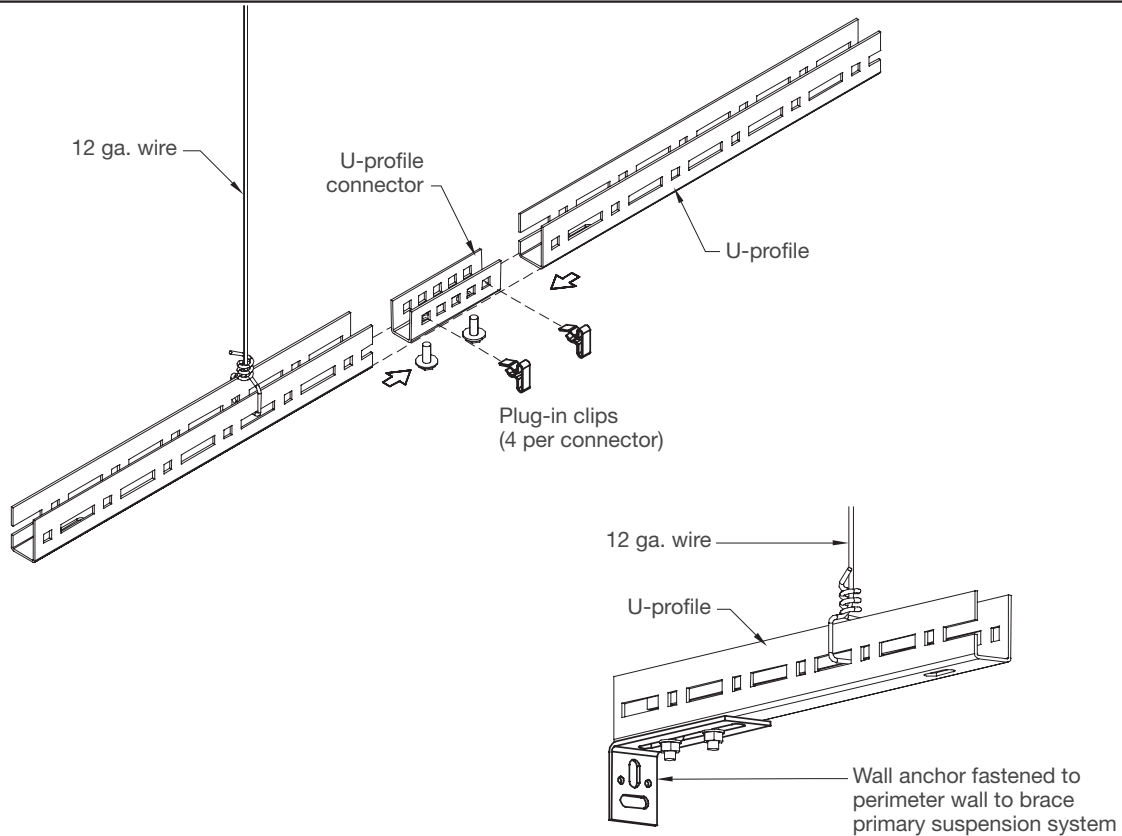

INSTALLATION OF J-BAR HANGERS

Install the required J-Bar hangers onto the U-profile at the center spacing indicated by the ceiling panel layout. The J-Bar hanger will slip over the U-profile and lock over the top edge.

Note – J-Bar hangers are directional.

Slide the J-Bar hanger to the required location and secure to the U-profile with a plug-in clip. The long leg of the plug-in clip should always be on top near the open side of the U-profile. This allows easy removal by pressing with your finger if you need to remove the clip.

The J-Bar hanger will be 1-3/16" from the ceiling panel joint.

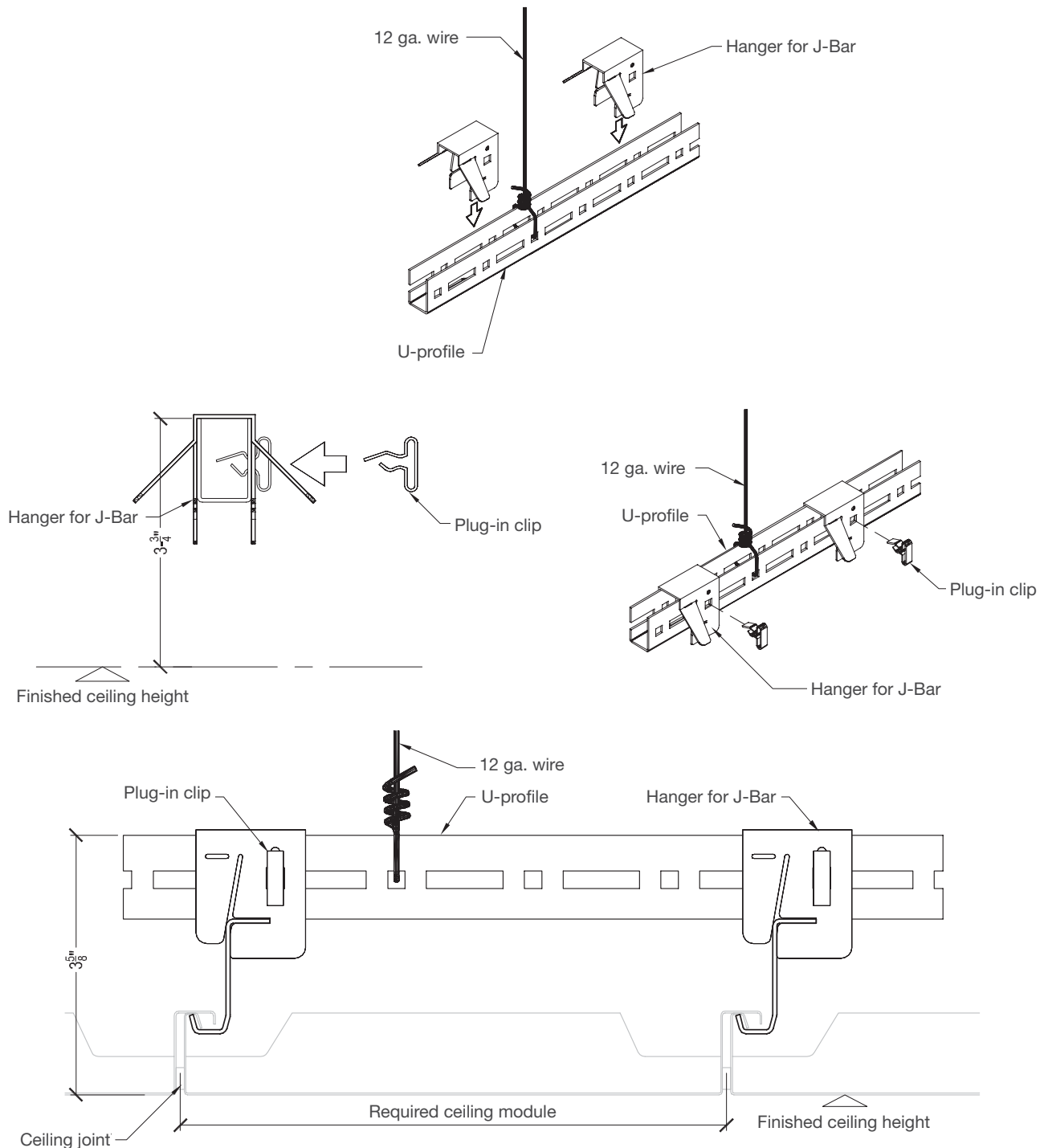

Drawing 3

INSTALLATION OF J-BAR

After the J-Bar hangers are installed, slide the top straight leg of the J-Bar into the slot.

Tighten the supplied bolt to 15 in./lbs. torque.

J-Bars must be leveled within 1/4" in 10' and must be square to the U-profile within 1/16" in 2'.

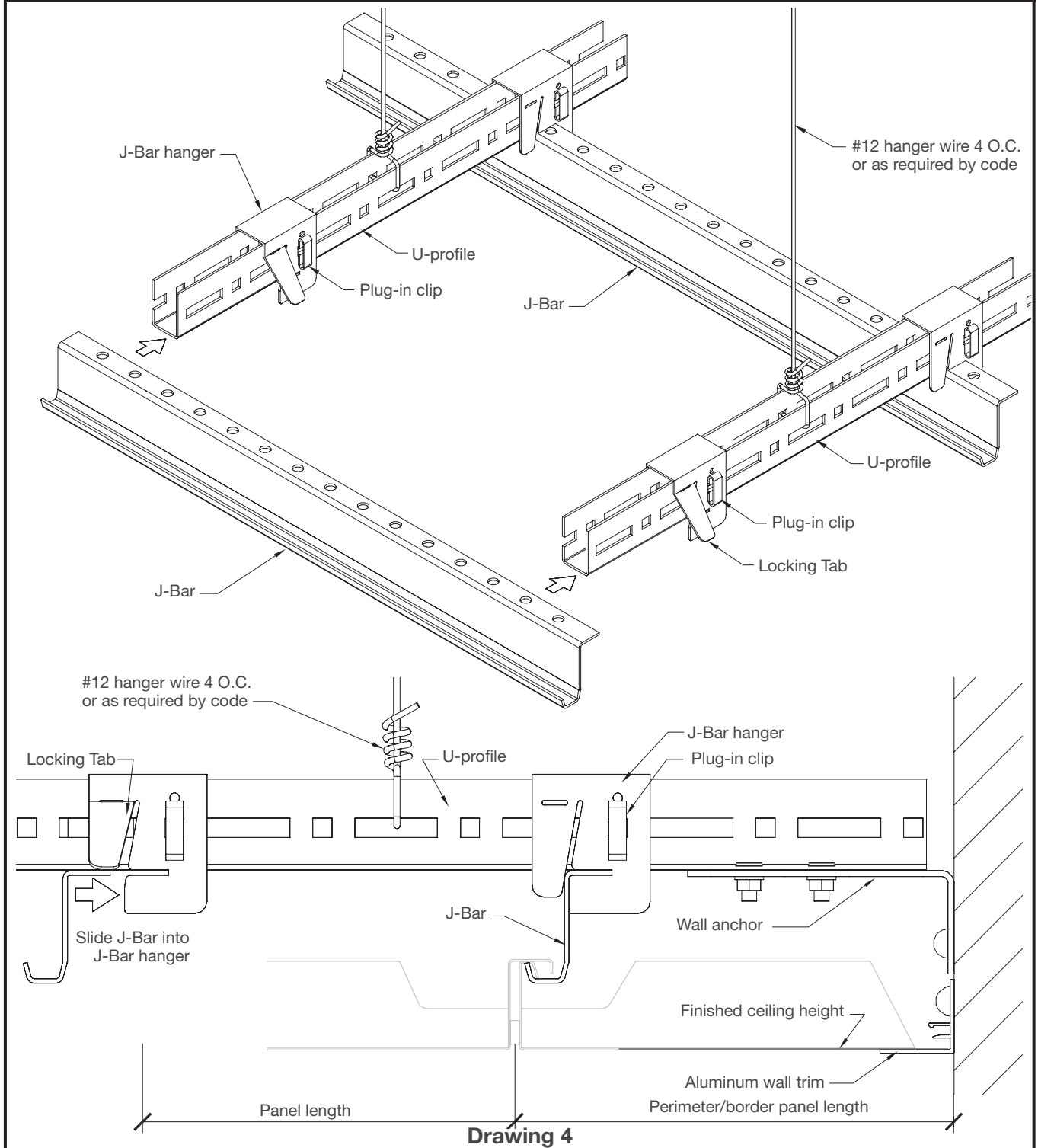

SPLICING J-BAR AND ATTACHING TO THE PERIMETER WALL

Use the J-Bar splice to join sections of J-Bar. Slide the J-Bar splice over the sections to be joined and tighten bolt to 60 in./lbs. torque.

J-Bar splice options:

Join two (2) #7 self-tapping sheet metal screws to directly fasten top plate to J-Bar.

Use a wall anchor to fasten the J-Bar to the perimeter wall. Securely attach the wall anchor to the wall and fasten it to the J-Bar using self-drill sheet metal screws.

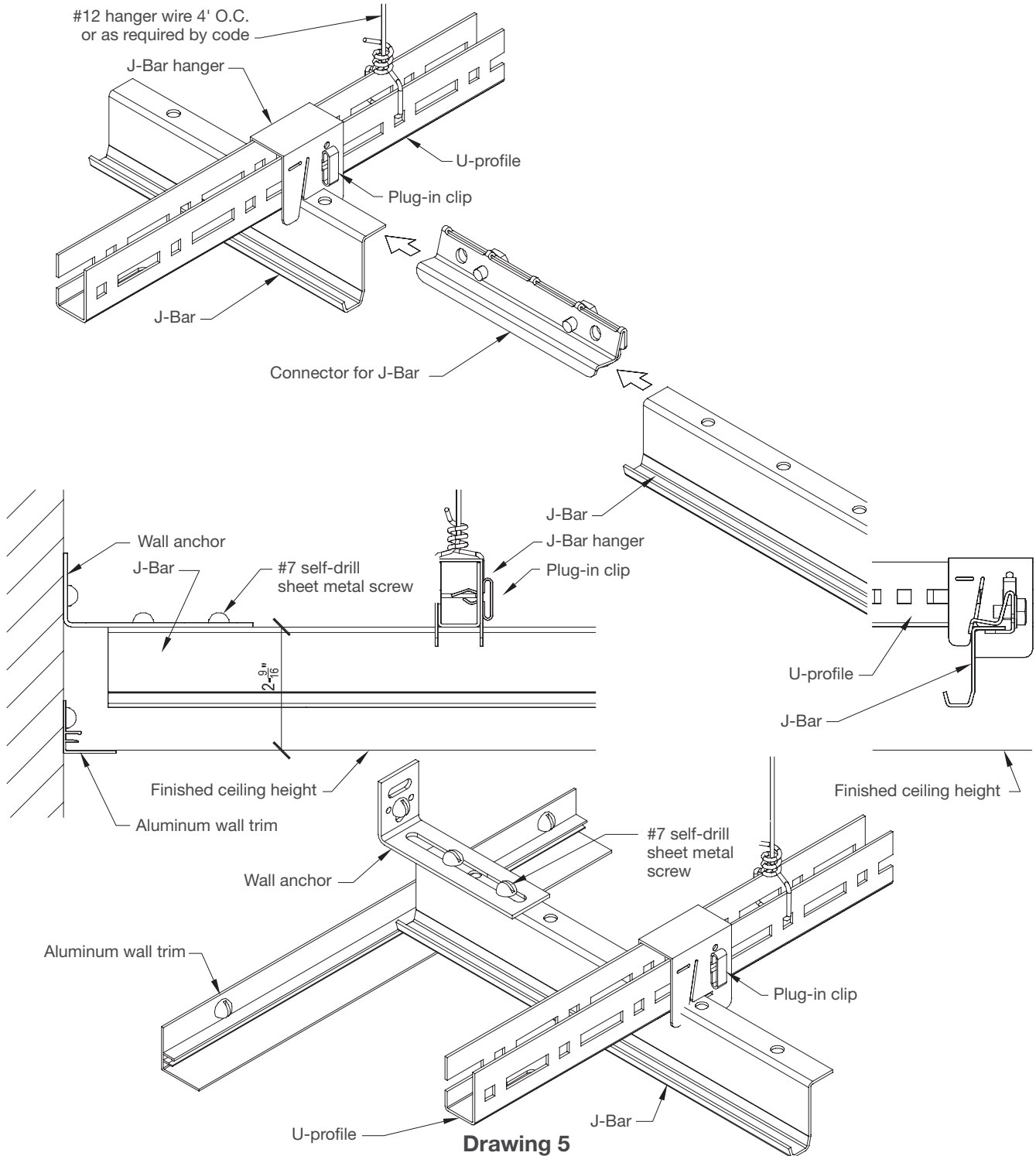

RH200 PANEL INSTALLATION

The metal ceiling panels are installed as specified on the ceiling layout drawing. Panel installation is directional. The use of a laser or string line is recommended to establish straight panel alignment. A row of properly aligned panels may be secured to the J-Bars to maintain full ceiling alignment.

A foam gasket must be used between all panel joints at the J-Bar and recommended on the unsupported edges to ease panel installation and alignment.

An optional security clip may be fastened to the J-Bar to prevent panel removal if required. The system is non-accessible if security clips are installed.

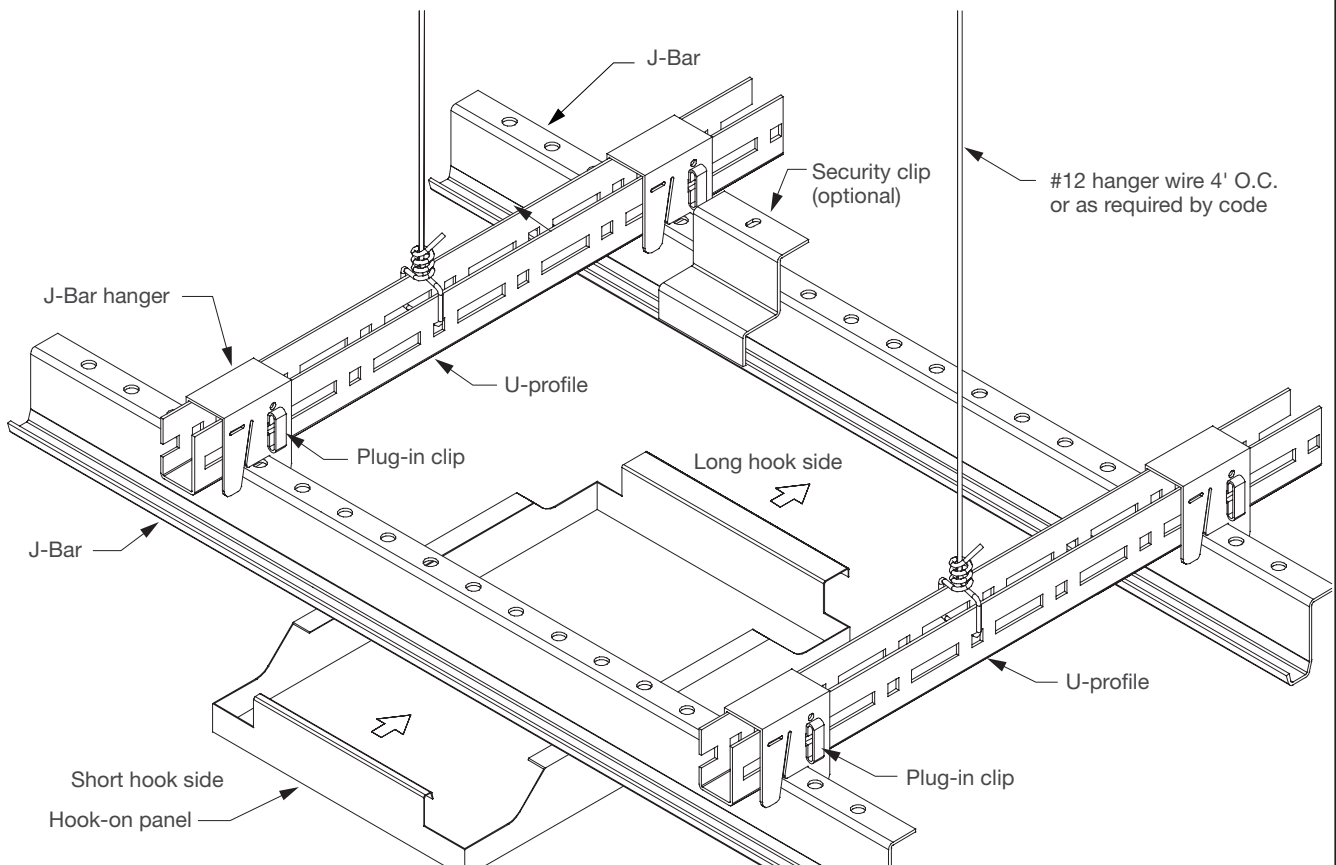
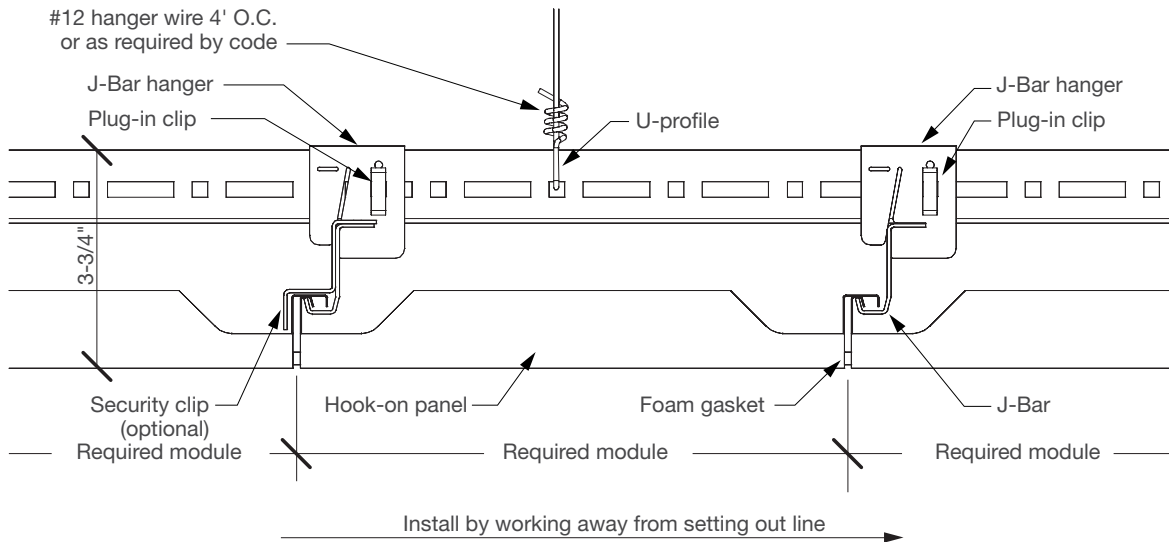

Drawing 6

RH200 PERIMETER PANEL INSTALLATION

Perimeter panels will have to be cut and fit as needed.
Carefully measure and cut the metal ceiling panel to fit the specified trim option.
The use of electrical sheet metal shears is recommended.
Install the panel and secure the cut edge as specified.
Check for proper ceiling tile alignment.

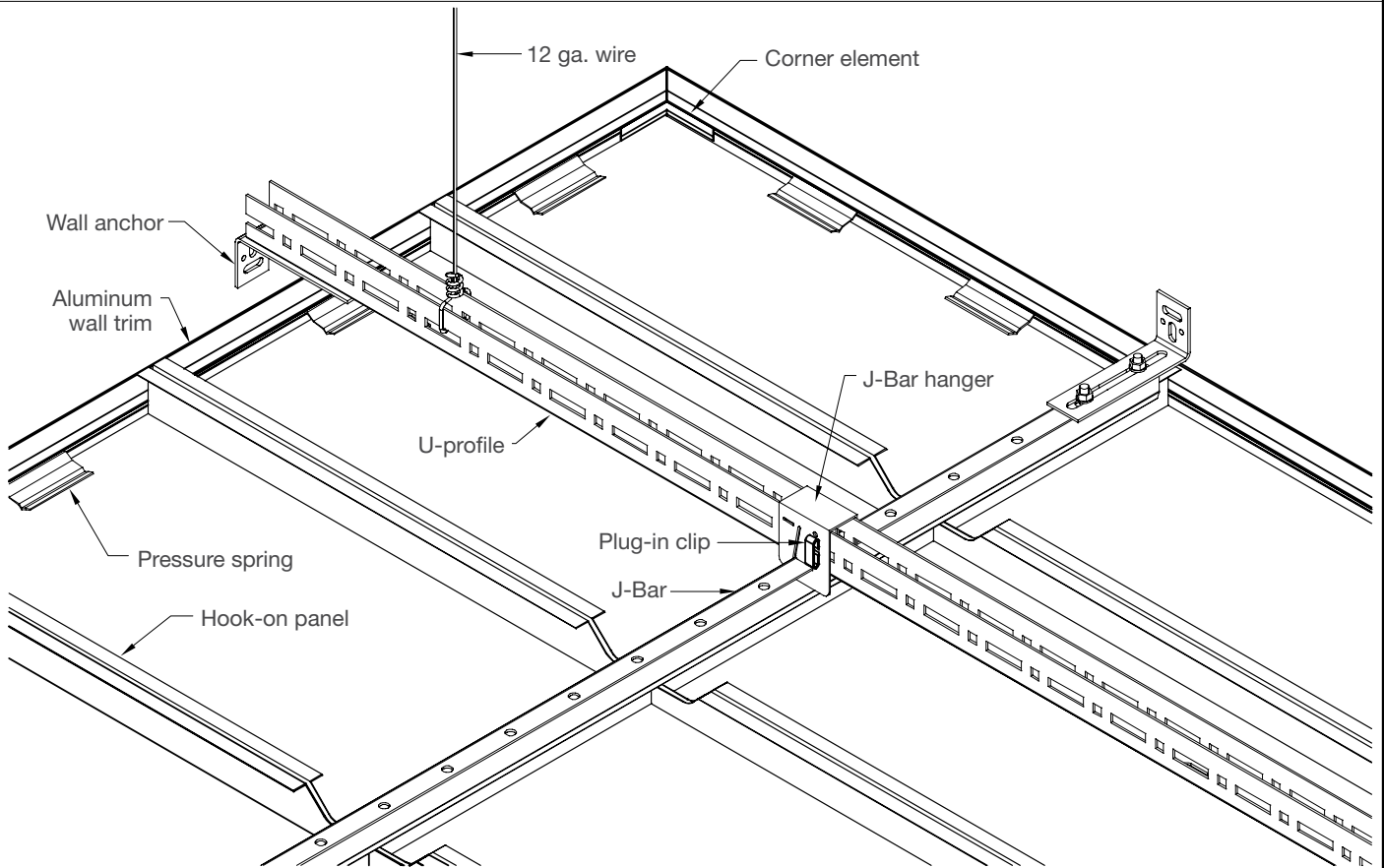
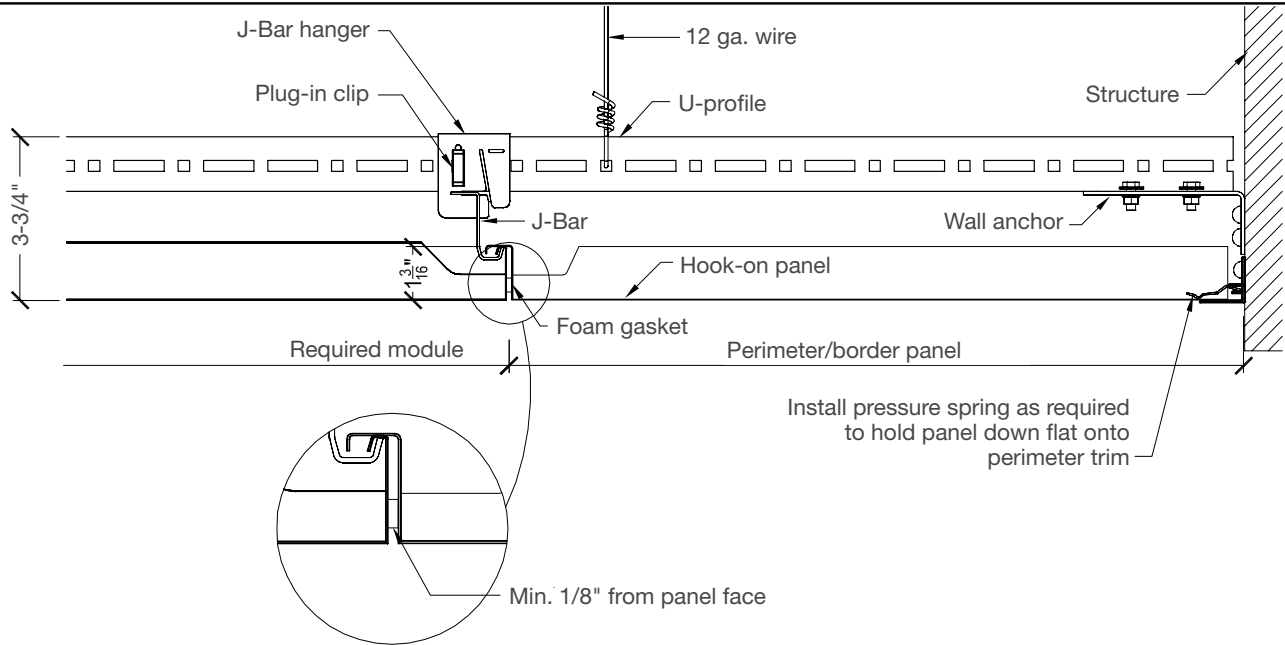

Drawing 7

ALUMINUM F-MOLDING PERIMETER WALL TRIM OPTIONS

Wall moldings must be fastened to the wall every 16" to 24".

Install the perimeter panel and secure the cut edge with pressure springs pushed into the channel as required.

Use the shadow molding for a reveal along the perimeter wall.

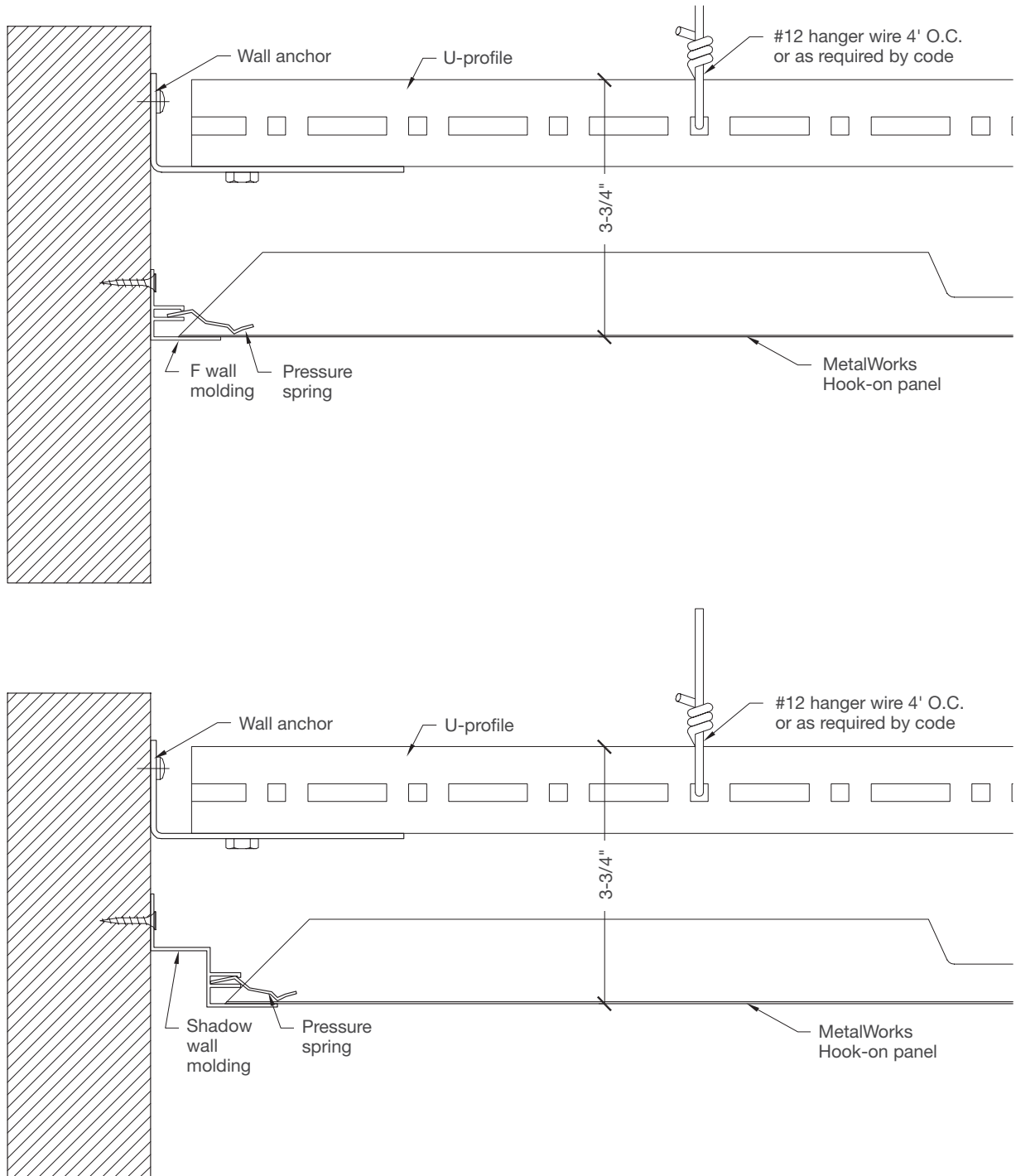

Drawing 8

OTHER PERIMETER WALL OPTIONS

Channel molding:

Use channel molding #7831. Install the perimeter panel and secure the cut edge with the spreader channel #7830SC.

Full panel modules at the perimeter or corridor applications:

Need a minimum of 1/2" clearance between the wall and panel end. Use a standard wall angle installed slightly above the J-Bar lip to conceal the suspension system from the line of sight if required.

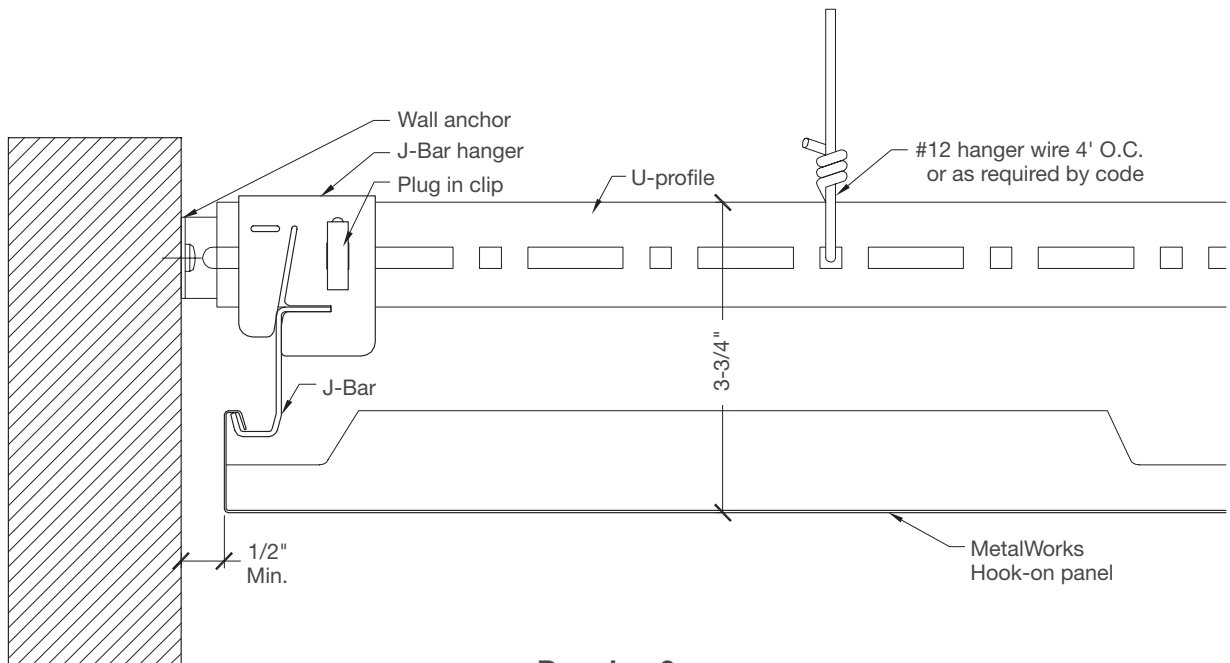
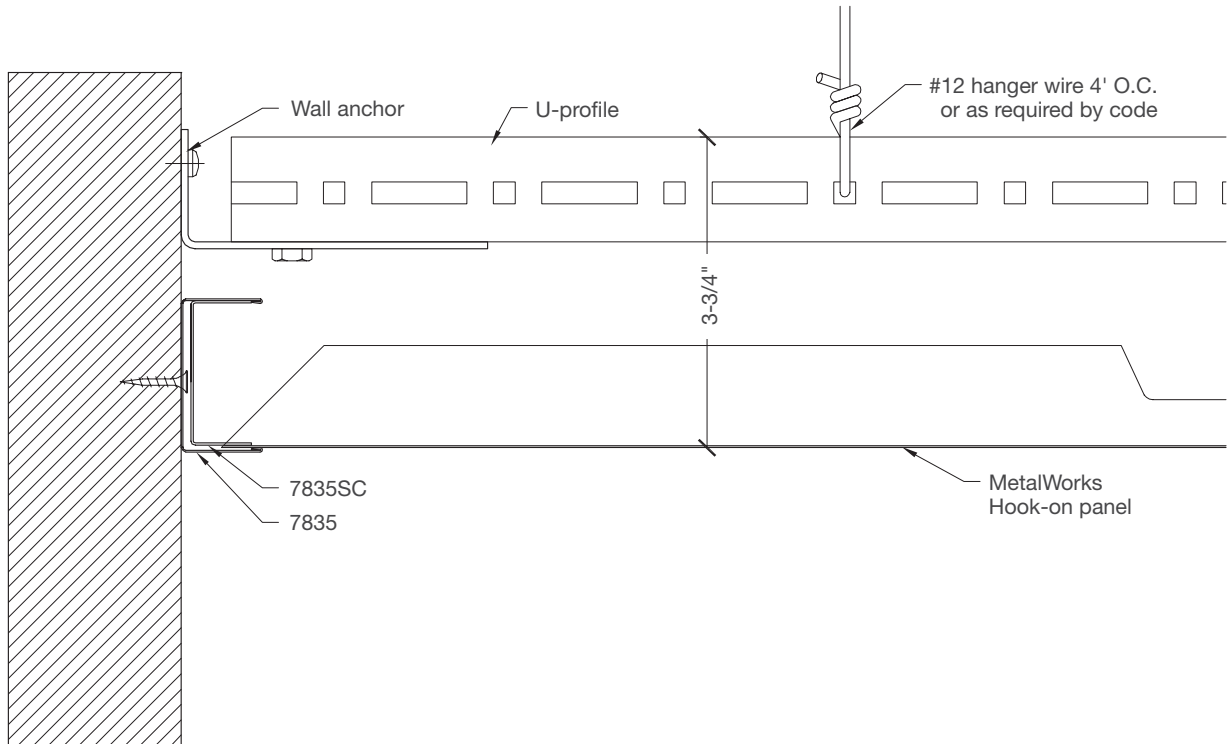

Drawing 9

INSTALLATION AND REMOVAL OF METALWORKS™ RH200 PANELS

INSTALLATION OF METALWORKS RH200 PANELS

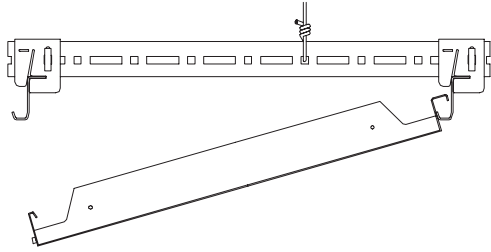

Step 1 – Fully insert the long hook side of panel above J-Bar.

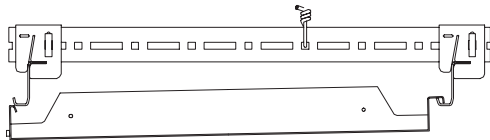

Step 2 – Raise short hook side of panel slipping up above J-Bar.

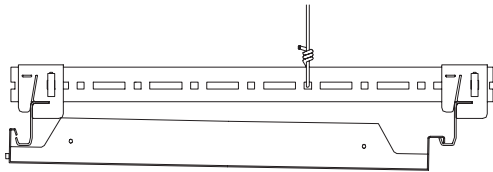

Step 3 – Make sure that short hook side lines up above J-Bar before sitting panel on J-Bar.

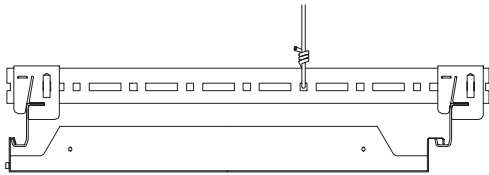

Step 4 – Lower MetalWorks panel onto J-Bar. Check panel(s) for proper alignment.

REMOVAL OF METALWORKS RH200 PANELS

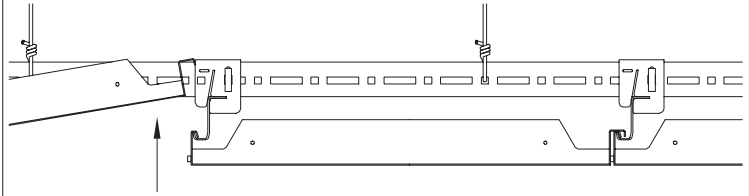

Step 1 – Carefully lift and hold adjacent panel edge.

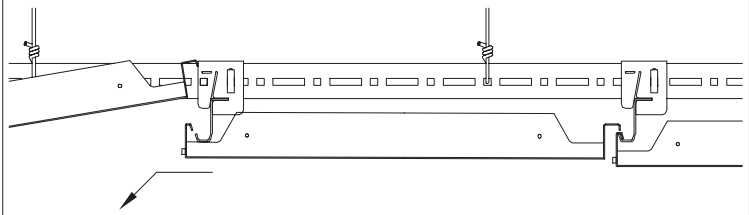

Step 2 – Raise desired panel for removal by lifting short hook side first (place free hand at middle of panel for best results). Next, slide panel toward short hook side and tilt panel down carefully past bottom of J-Bar. Lower adjacent panel back onto J-Bar.

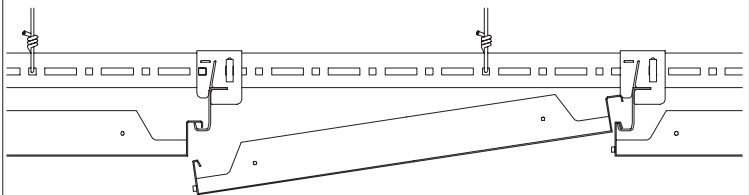

Step 3 – Raise long hook side up past top of J-Bar hook, keeping panel at an angle for removal.

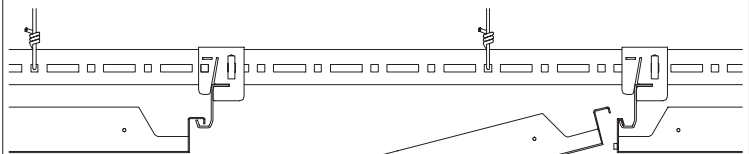

Step 4 – Lower MetalWorks panel from the ceiling. Place adjacent panel properly back onto J-Bar. Make sure panels are properly secured.

Drawing 10

RH200 (SEISMIC) PANEL INSTALLATION

Splice adjoining J-Bars with the top section of the J-Bar splice plate and 4 self-drilling sheet metal screws.

All RH200 hook-on panels must have two MetalWorks™ seismic clips installed to maintain secure engagement on the J-Bar.

It is recommended that a full row of RH200 panels be securely fastened to the J-Bar. Use self-drilling sheet metal screws through the panel hook into the J-Bar. Depending on panel width and ceiling accessibility, secure a row of panels every 8 to 12 feet.

Typical system restraint is the 4-wire cluster splay bracing and compression post. This must be made at an intersection of U-profile and J-Bar. Refer to the local authority for restraint system requirements.

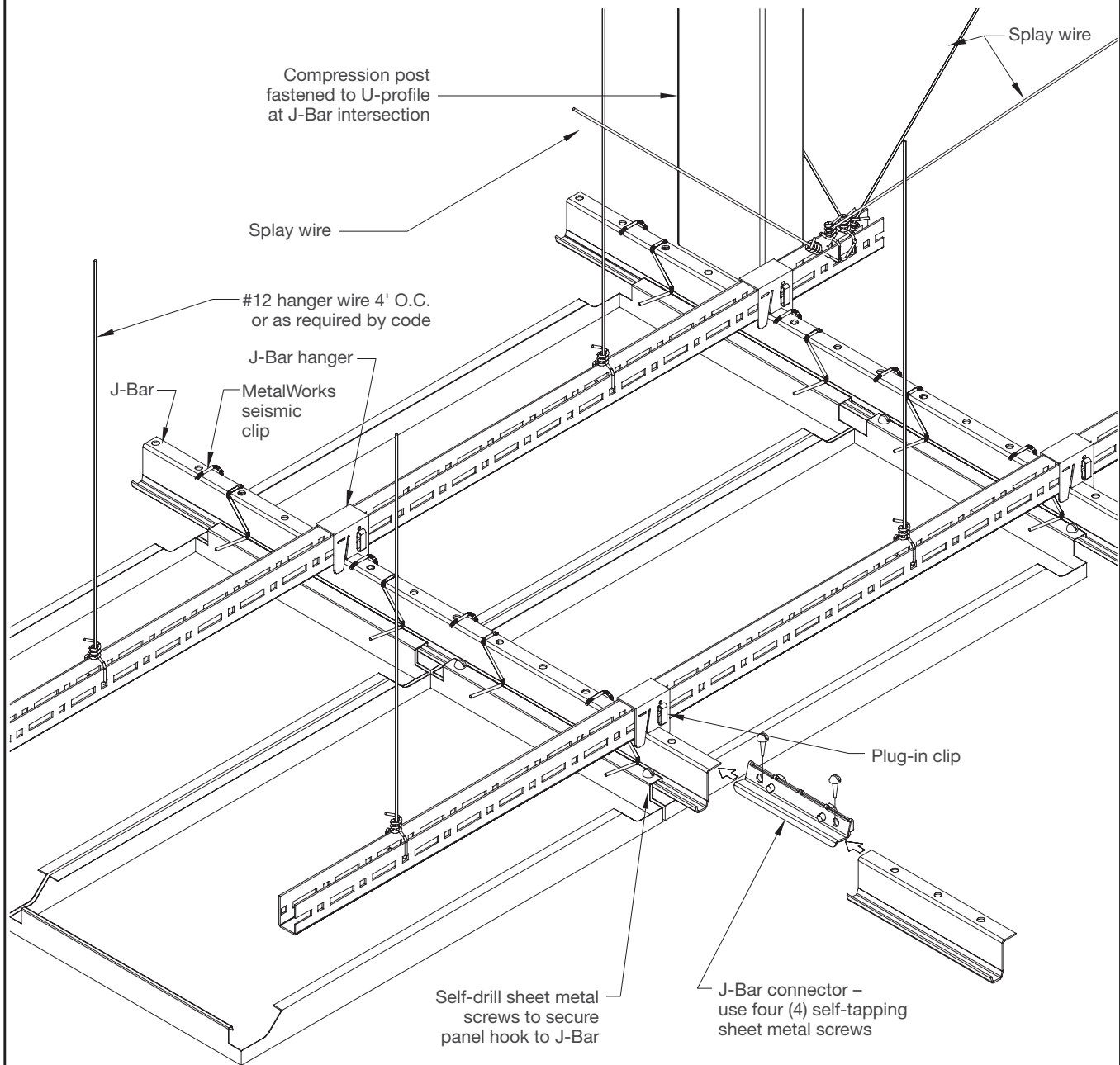

Drawing 11

RH200 (SEISMIC) PERIMETER PANEL INSTALLATION

U-profiles and J-Bars must be positively attached to two adjacent perimeter walls using the wall anchor. The opposite walls must have 3/4" clearance. Fasten the wall anchor to the wall with fasteners as required. Secure the U-profile or J-Bar to the wall anchor with bolts or self-drilling sheet metal screws.

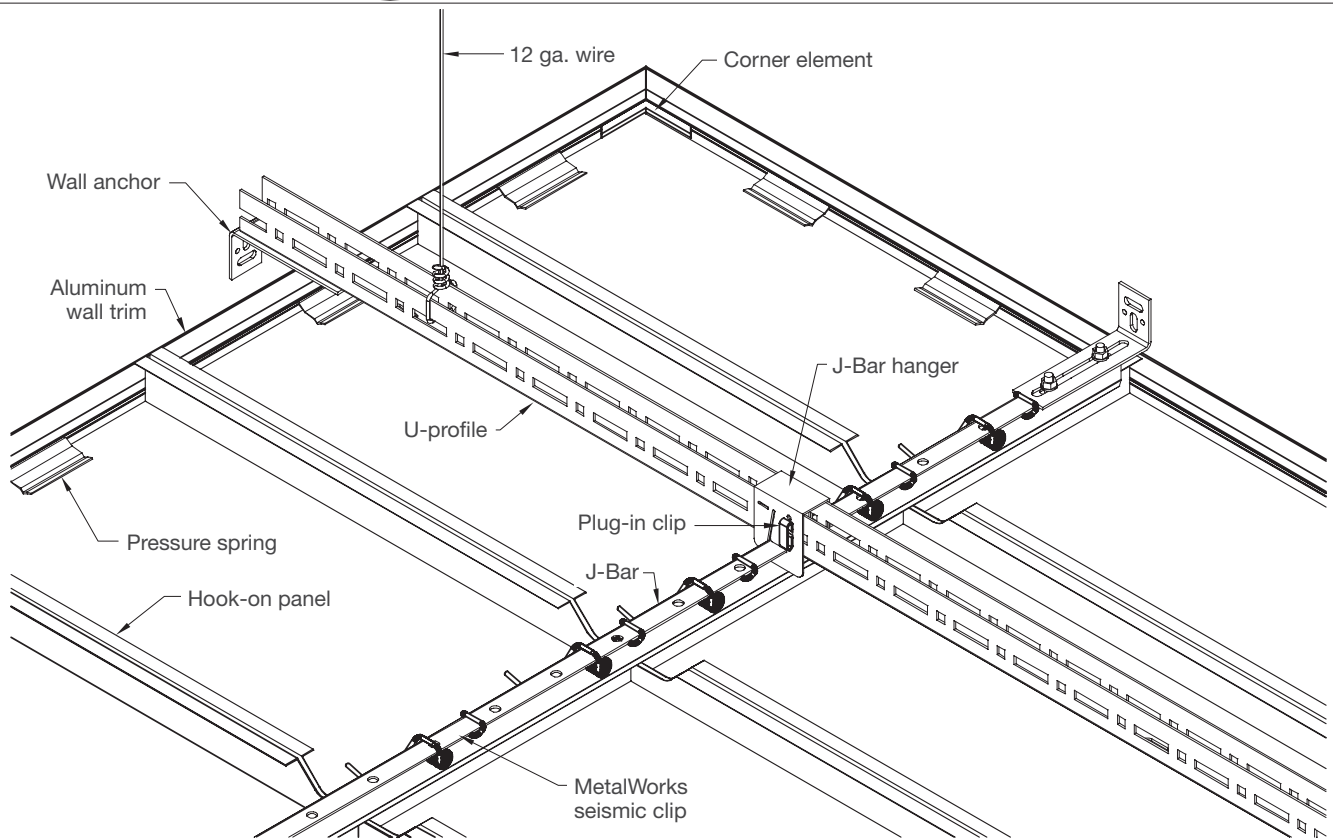
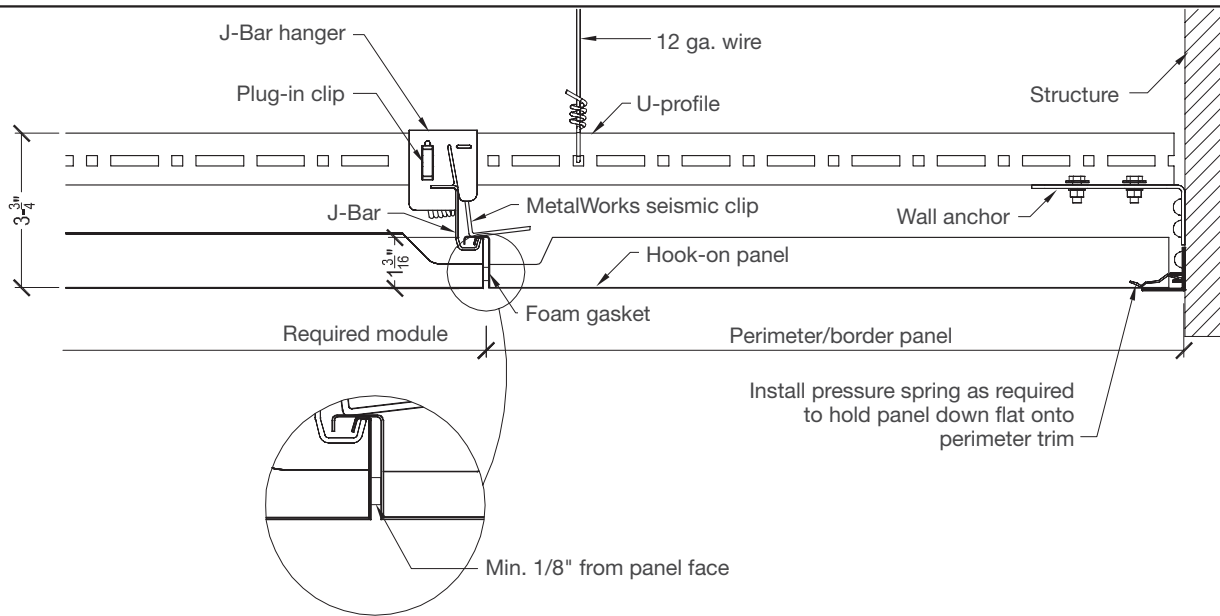

Drawing 12

RH200 (SEISMIC) PERIMETER WALL OPTIONS

Perimeter panels that require field cutting to fit on a wall trim option must have a minimum of 5/8" edge resting on the horizontal surface of the wall trim. All perimeter panel hook ends must have two (2) MetalWorks™ seismic clips to maintain secure engagement on the J-Bar.

Full panel perimeter installation, either within 1/2" of a wall or a floating cloud, require the short hook end detail and an outward facing J-Bar installation. If the MetalWorks seismic clip cannot be installed due to panel end interference or an unacceptable visual, use optional seismic hold down clip BP6036. This clip is fastened to the top of the J-Bar with a self-drilling sheet metal screw.

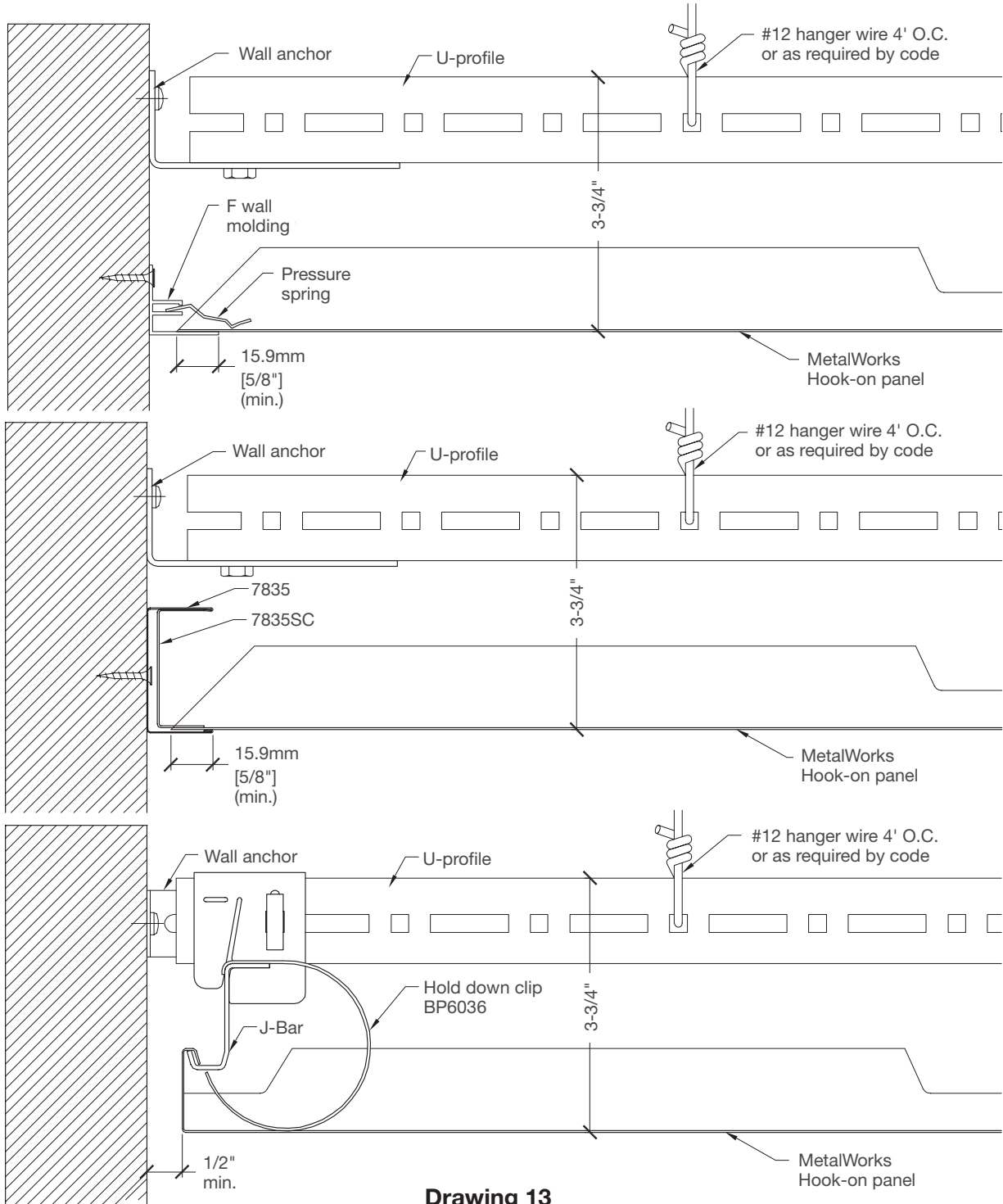

Drawing 13

MORE INFORMATION

For more information, or for an Armstrong representative, call 1 877 276 7876.

For complete technical information, detail drawings, CAD design assistance, installation information, and many other technical services, call TechLineSM services at 1 877 276 7876 or FAX 1 800 572 TECH.

For the latest product selection and specification data, visit armstrongceilings.com/metalworks.

U.S. Patents Pending, including US Publication No. 2004/0182022.

All trademarks used herein are the property of AWI Licensing Company and/or its affiliates
© 2013 AWI Licensing Company • Printed in the United States of America

BPLA-295804-413

