

METALWORKS™ Torsion Spring for Exterior Applications

Assembly and Installation Instructions

1. GENERAL

1.1 Product Description

MetalWorks™ Torsion Spring for exterior applications is a downward accessible aluminum ceiling panel available in standard 24" x 24" and 24" x 48" sizes. It is designed to install on a 15/16" Prelude® suspension system that includes items that are pre-slotted to accept the factory-applied panel springs. All non-cut panels are 100% downward accessible. (Fig 1)

1.2 Standard Installation

MetalWorks Torsion Spring uses a standard 15/16" suspension system for exterior applications. The elements of the system include pre-slotted Prelude XL 15/16" main beams and cross tees, along with standard Prelude XL cross tees, all made of hot dipped G90 galvanized steel. The installation shall in all cases conform to the requirements of the International Building Code and its referenced standards.

This instruction sheet provides details for the proper application of these products in areas requiring resistance to wind uplift forces. Please refer to standard MetalWorks Torsion Spring Installation Instructions (BPLA-297833) for general information regarding the installation of Torsion Spring panels and the supporting suspension.

The details and descriptions provided in this document for MetalWorks Torsion Spring exterior installations depict the method used during independent testing conducted according to the "Standard for Tests for Uplift Resistance of Roof Assemblies" UL 580. The result of these tests determined the class rating.

1.3 Surface Finish

MetalWorks™ Torsion Spring panels for exterior applications are pre-coated aluminum unperforated panels and post-coated aluminum perforated panels. Panels are available in three standard finishes: Whitelume (WHA), Silverlume (SLA), and Gun Metal (MYA).

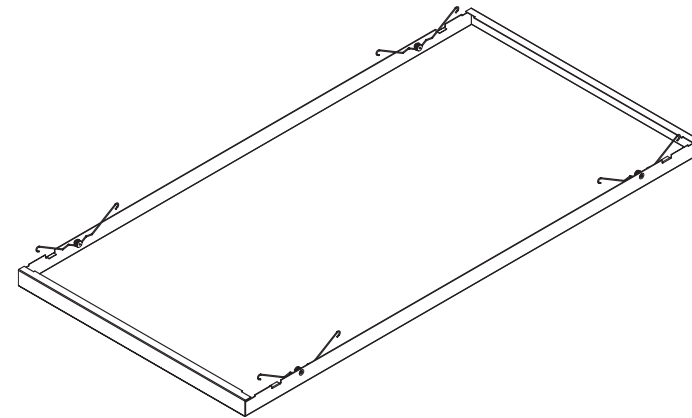

(Fig 1)

1.4 Storage and Handling

Ceiling panels shall be stored in a dry interior location and shall remain in cartons prior to installation to avoid damage. The cartons shall be stored in a vertical position. Proper care should be taken when handling to avoid damage or soiling.

NOTE: MetalWorks Torsion Spring panels may be packaged with the face of the panel toward the outside of the carton. Exercise care in moving and opening cartons to prevent damage to the panel face.

2. SUSPENSION SYSTEM

2.1 For 24" x 24" and 24" x 48" panels: Prelude® XL HD exterior main beams that are pre-slotted 6" O.C. (item 7301G90TS) for Torsion Spring panels are installed every 24" O.C. Then 24" Prelude cross tees (item XL7321G90) shall intersect the main beams at 90 degrees every 24" or 48". Springs on the panel will be inserted into main beams. (*Fig 2*)

The suspension system for both panel sizes must be leveled to within 1/4" in 10' and must be square to within 1/16" in 2'. 90° Alignment Clips (item 7134) can be used to assure the suspension system meets the squareness requirement.

2.2 Location of the first main beam shall be as detailed on the reflected ceiling plan, so as to provide borders that are equal in size and greater than one-half of the full panel width. Pay close attention when cutting this first main beam to length; make sure that the slots in the main beam are in the correct position to accept the springs attached to the panel size being installed.

2.3 Perimeters are trimmed with item 7125 Box Molding attached with appropriate fasteners. The suspension system will rest on the upper 2" flange of the box molding and the panel edges will rest on the bottom 1" flange. (*Fig 3*)

2.4 Cut edges are held down against the molding by inserting a 7126 Spreader Hold Down into the molding, between the upper and lower flanges, over each cut panel. The 7126 Spreader Hold Down is 10.625" long, so use the appropriate amount of hold downs for the panel edge dimension. (*Fig 4, next page*)

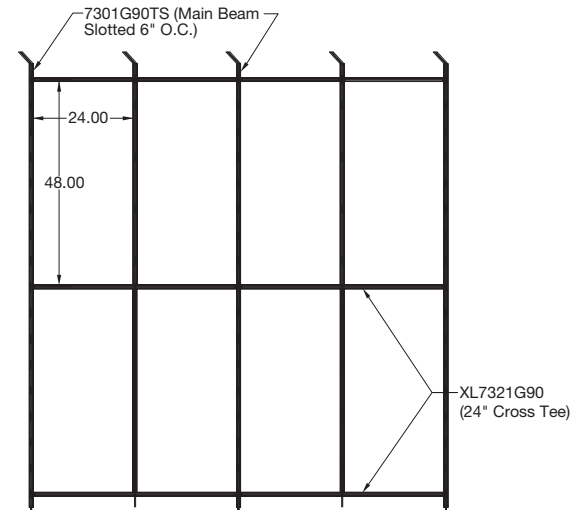

(Fig 2)

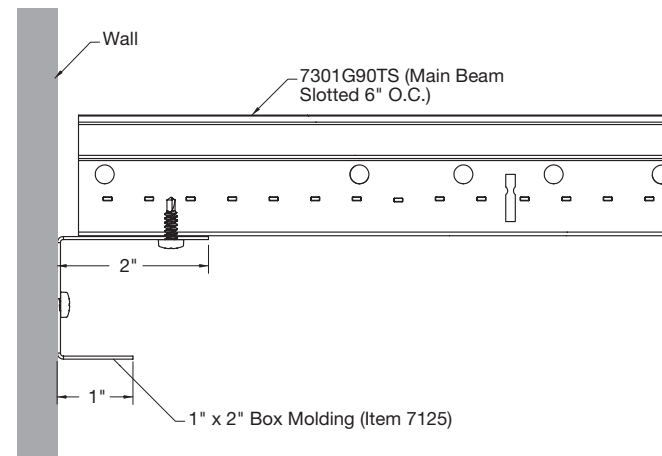

(Fig 3)

3. INSTALLATION OF THE COMPRESSION POSTS

3.1 Compression posts are required to brace the T-Bar main beams of the suspension system. The size and shape of the post material must be designed to meet the requirements of the particular application. Independent testing was successfully conducted to Class 30, Class 60, and Class 90 using 20 gauge steel stud (CSJ flange measuring 2-1/2" deep, with a 1-5/8" flange width) at a length of 30".

3.1.1 Compression post requirements for each Class are listed below.

- UL 580 Class 30, 60, or 90 – Compression posts 2' on center along T-Bar main beam

3.2 Posts 2' O.C. are to be placed on the main beams adjacent to the intersections of the cross tees.

Additionally, posts must be installed at the location of the main beam splices. These posts shall be secured by screws placed on either side of the splice detail.

3.3 Note that the bottom end of the post should extend approximately 3/8" below the bottom of the bulb of the main beam for attachment to the main beam and clip. Trim the sides of the post at an angle to ease panel insertion.

3.4 The top end of the post is fashioned by cutting through the flanges of the post and folding over a short horizontal leg of approximately 3". The top end of the post shall be attached to the structure by means of at least two metal fasteners of a type and size appropriate for the application.

3.5 Attachment to the suspension system shall be by means of the Armstrong BACG90A clip. Begin by clamping the post and BACG90A clip in position. Then use four #8 x 1/2" self-drilling sheet metal screws to fasten the post to the BACG90A clip. The top screws will fasten the post to the clip and the bottom screws will fasten the post and suspension system to the clip. (Fig 5)

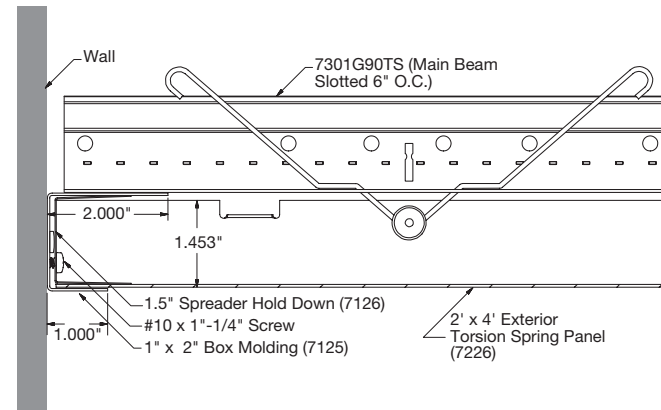

(Fig 4)

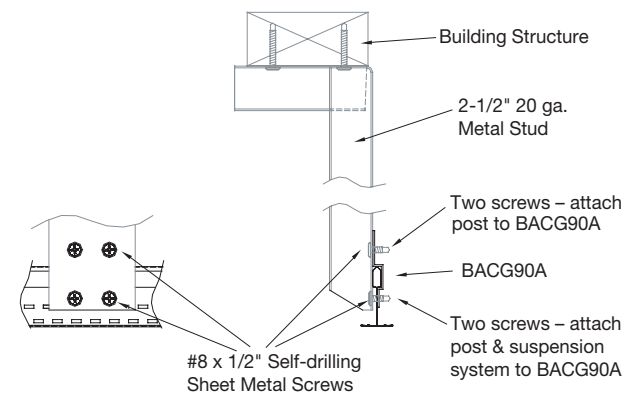

(Fig 5)

Compress Post Detail

4. PANEL INSTALLATION

Panels are mechanically directional. Two opposite sides feature a set amount of springs that engage the main beam and retain the panel.

- 4.1 Align the springs with the slots in the flange of the main beam or cross tee. Compress the spring and insert it into the corresponding slot. Follow this same process for each spring on the panel. Then press up into place with the palm of the hand. The springs should spread apart in the slots of the suspension system and seat the panel into place. (Fig 6-8)

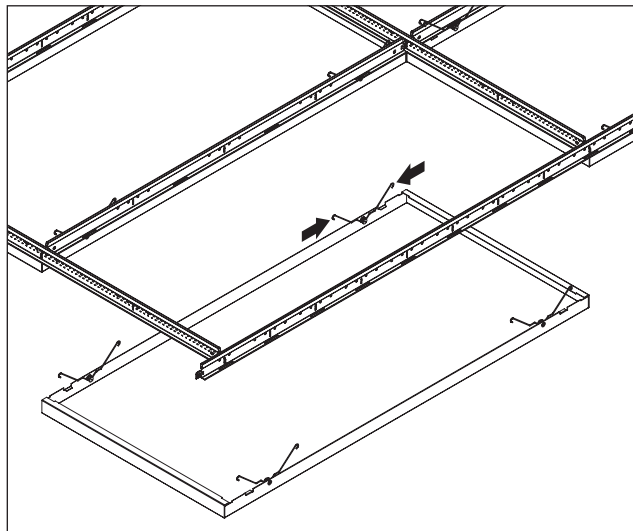

(Fig 6)

STEP 1

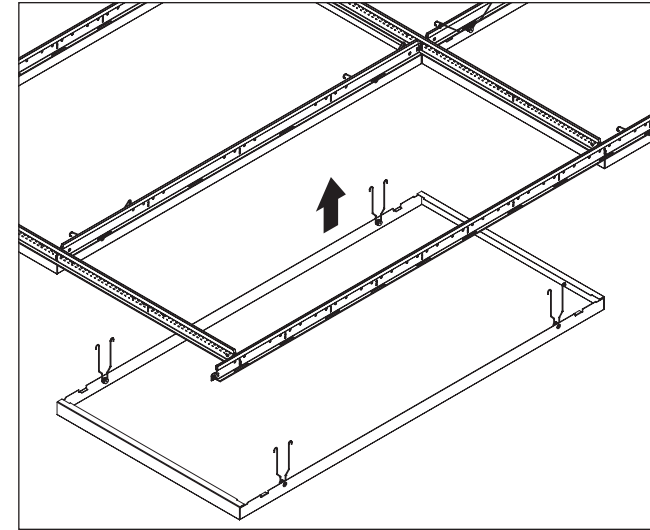

(Fig 7)

STEP 2

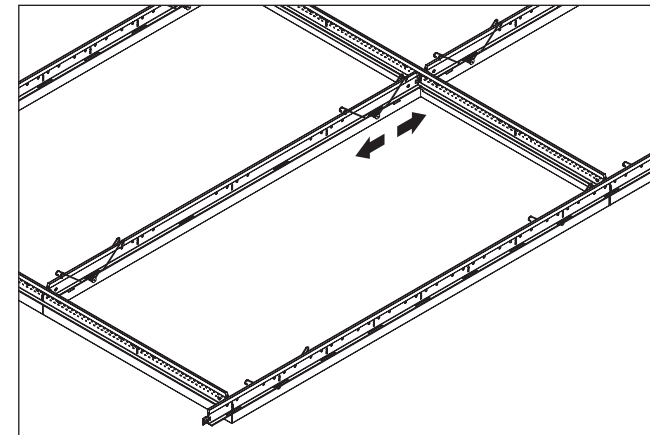

(Fig 8)

STEP 3

4.2 Cut Panels

Cut panels should never occur within the field of the ceiling. All ceiling mounted services must either replace a full panel, install into a hole that is cut into a panel, or be mounted through the face of a panel.

4.2.1 See MetalWorks™ Cutting Instructions LA-295518 for detailed information about cutting Armstrong metal ceilings. This document discusses the advantages and disadvantages of several types of equipment and how they are used when cutting our products.

4.3 Panel Removal

All panels are removable without moving up into the plenum.

4.3.1 The Hook Panel Removal Tool, item 7129, for perforated or unperforated panels, is inserted into the joint between two panels. Make sure you insert the tool within 1" from a panel intersection to grab the correct part of the panel. Twist the tool 90 degrees to hook the top of the panel. Then pull the tool downward, slowly, until the spring catches on the flange of the suspension system and can be seen. Now that the spring has become accessible, push the spring together, slide it down through the slot, and pull down gently to release the panel from the main beam. (Fig 9-12)

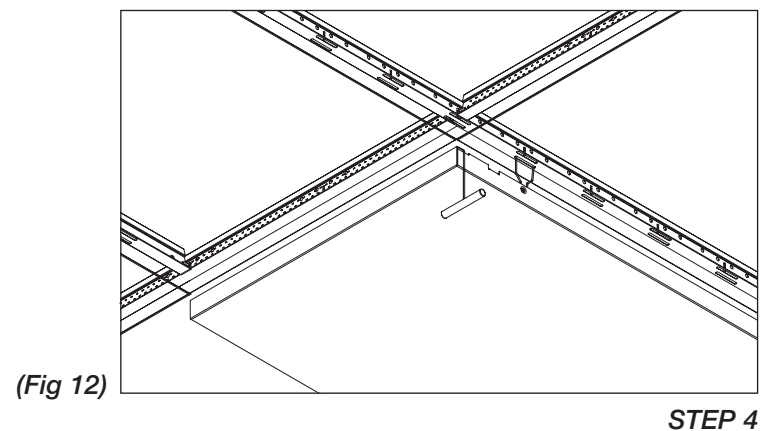
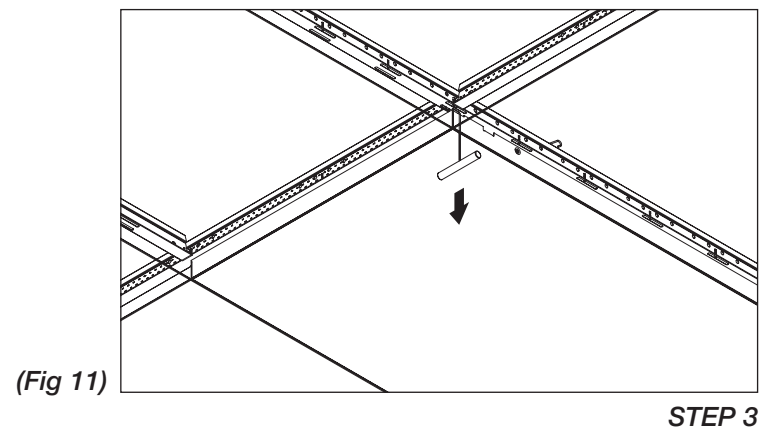
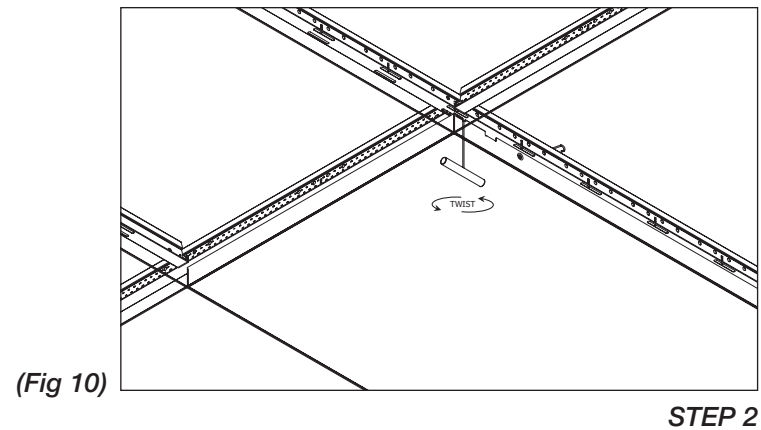
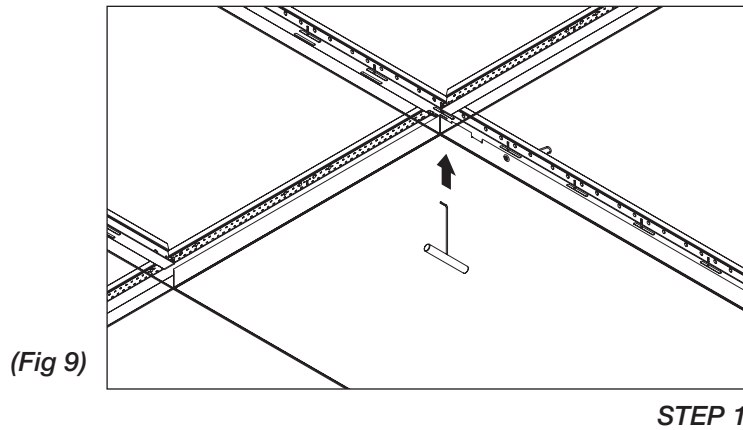

The Suction Panel Removal Tool (item 7130) is for unperforated panels only. Place the device on the corner edge of the panel and gently pull down until the spring is accessible. Push the spring together and pull down gently to release the panel from the main beam.

4.3.2 Adjacent panels may be removed from the same row of main beams without further use of the tool.

5.0 SEISMIC INSTALLATION

MetalWorks™ Torsion Spring has been engineered and tested for application in all seismic areas.

MORE INFORMATION

For more information, or for an Armstrong Ceilings representative, call 1 877 276-7876.

For complete technical information, detail drawings, CAD design assistance, installation information, and many other technical services, call TechLine customer support at 1 877 276-7876 or FAX 1 800 572-TECH.

All trademarks used herein are the property of AWI Licensing LLC and/or its affiliates.
© 2021 AWI Licensing Company Printed in the United States of America

BPLA-297922-921

