

# METALWORKS™ Torsion Spring

## Assembly and Installation Instructions

### 1. GENERAL

#### 1.1 Product Description

MetalWorks™ Torsion Spring is a downward accessible aluminum ceiling panel available in standard 2' x 2', 2' x 4', 2' x 6', 2' x 8', and 30" x 30" sizes. It is designed to install on a 15/16" Prelude® suspension system that includes items that are pre-slotted to accept the factory-applied panel springs. All non-cut panels are 100% downward accessible. (Fig 1)

#### 1.2 Standard Installation

MetalWorks Torsion Spring uses a standard 15/16" suspension system. The elements of the system include pre-slotted Prelude® XL® 15/16" main beams and standard Prelude XL cross tees. The installation shall in all cases conform to the requirements of the International Building Code and its referenced standards.

#### 1.3 Surface Finish

MetalWorks Torsion Spring panels are pre-coated aluminum and available in six standard perforations or unperforated. The perforated finishes have a black acoustical fleece factory-applied to the backside of the panel.

Optional BioAcoustic™ (item 5823) and fiberglass (item 8200T10) infill panels are available for increased sound absorption.

#### 1.4 Storage and Handling

Ceiling panels shall be stored in a dry interior location and shall remain in cartons prior to installation to avoid damage. The cartons shall be stored in a vertical position. Proper care should be taken when handling to avoid damage or soiling.

**NOTE:** MetalWorks Torsion Spring panels may be packaged with the face of the panel toward the outside of the carton. Exercise care in moving and opening cartons to prevent damage to the panel face.

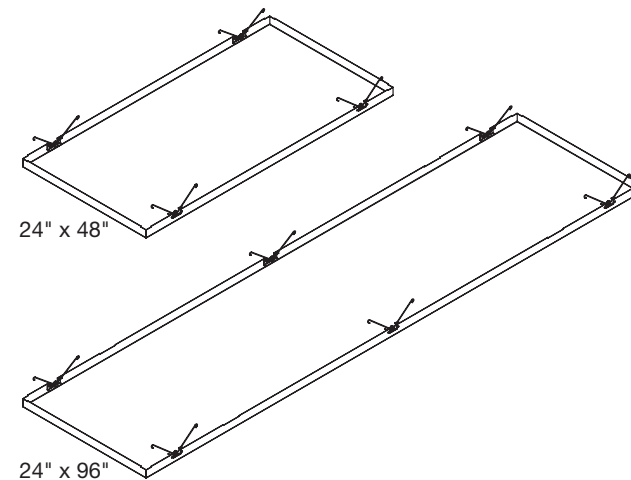

(Fig 1)

## **1.5 Site Conditions – Painted Panels**

Areas to receive ceilings shall be free of construction dust and debris. Panels should only be installed in closed and acclimatized buildings. Interior systems cannot be used in exterior applications where standing water is present or where moisture will come in direct contact with the ceiling.

## **1.6 Site Conditions – Natural Reflections Panels**

MetalWorks™ Natural Reflections ceiling materials should be permitted to reach room temperature and have a stabilized moisture content for minimum of 72 hours before installation. (Remove plastic wrap to allow panels to climatize.) They should not, however, be installed in spaces where the temperature or humidity conditions vary greatly from the temperatures and conditions that will be normal in the occupied space.

### **1.6.1 HVAC Design & Operation**

Proper design for both supply air and return air, maintenance of the HVAC filters and building interior space are essential to minimize soiling. Before starting the HVAC system, make sure supply air is properly filtered and the building interior is free of construction dust.

### **1.6.2 Temperature & Humidity During Installation**

MetalWorks Natural Reflections panels are interior finish products designed for installation in temperature conditions between 50°F and 86°F, in spaces where the building is enclosed and HVAC systems are functioning and will be in continuous operation. Relative humidity shall not fall below 25% or exceed 55%. There shall be proper ventilation of the plenum in high moisture areas. All plastering, concrete, terrazzo, or any other wet work should be completely dry. All windows and doors should be in place. The heating, ventilating, and air-conditioning system should be installed and operable where necessary to maintain proper temperature and humidity conditions before, during, and after installation of the MetalWorks Natural Reflections panels.

## **1.7 Plenum**

Since panels are installed from below, MetalWorks Torsion Spring panels require minimal clearance above the suspension system. Panels never need to travel into the plenum space during installation or removal.

**NOTE:** Light fixtures and air handling systems require more space and will usually determine the minimum plenum height for the installation.

## 2. SUSPENSION SYSTEM

**2.1** For 2' x 2' and 2' x 4' panels: Prelude® XL® HD main beams that are pre-slotted 6" O.C. (item 7301TS) for MetalWorks™ Torsion Spring panels are installed every 48" O.C. Then 48" Prelude cross tees (item XL7341) shall intersect the main beams at 90 degrees every 48". Then a 48" Prelude cross tee that is slotted (item XL7341TS) at four locations shall be bridged in at the center of the 48" cross tees to run parallel with the main beams. Springs on the panel will be inserted into main beams and cross tee slots. *(Fig 2)*

**2.2** For 2' x 6' panels: Prelude XL HD main beams that are pre-slotted 6" O.C. (item 7301TS) for Torsion Spring panels are installed every 48" O.C. Then 48" Prelude cross tees (item XL7341) shall intersect the main beams at 90 degrees every 72". Then a 72" Prelude cross tee that is slotted (item XL7390TS) at three locations shall be bridged in at the center of the 48" cross tees to run parallel with the main beams. Springs on the panel will be inserted into main beams and cross tees. *(Fig 3)*

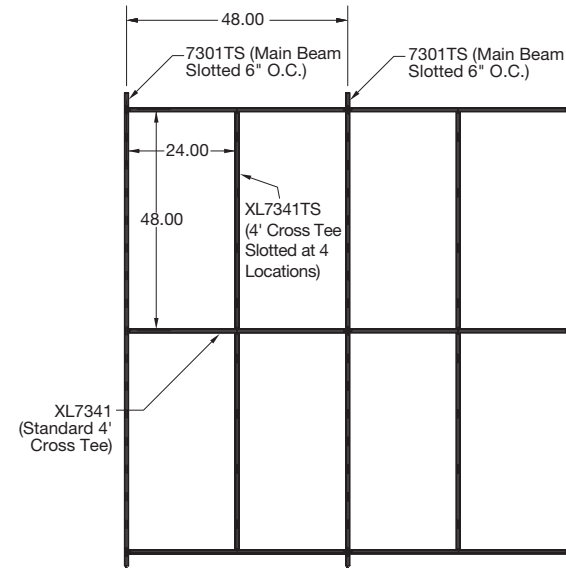

*(Fig 2)*

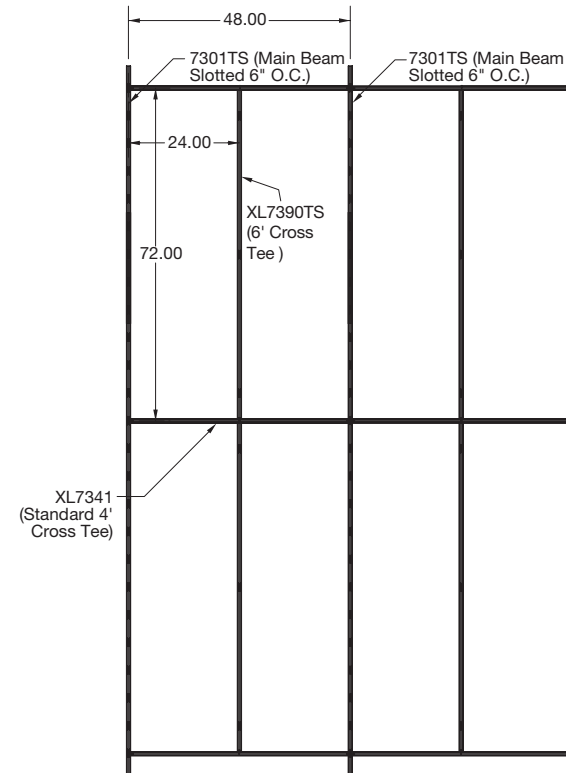

*(Fig 3)*

**2.3** For 2' x 8' panels: Prelude® XL® HD main beams that are pre-slotted 6" O.C. (item 7301TS) for MetalWorks™ Torsion Spring panels are installed every 24" O.C. Then 24" Prelude cross tees (item XL7328) shall intersect the main beams at 90 degrees every 96". Springs on the panel will be inserted into main beams only. **(Fig 4)**

**2.4** For 30" x 30" panels: Prelude XL HD main beams that are pre-slotted 6" O.C. (item 7301TS) for Torsion Spring panels are installed every 30" O.C. Then 30" Prelude cross tees (item XL7378) shall intersect the main beams at 90 degrees every 30". Springs on the panel will be inserted into main beams only. **(Fig 5)**

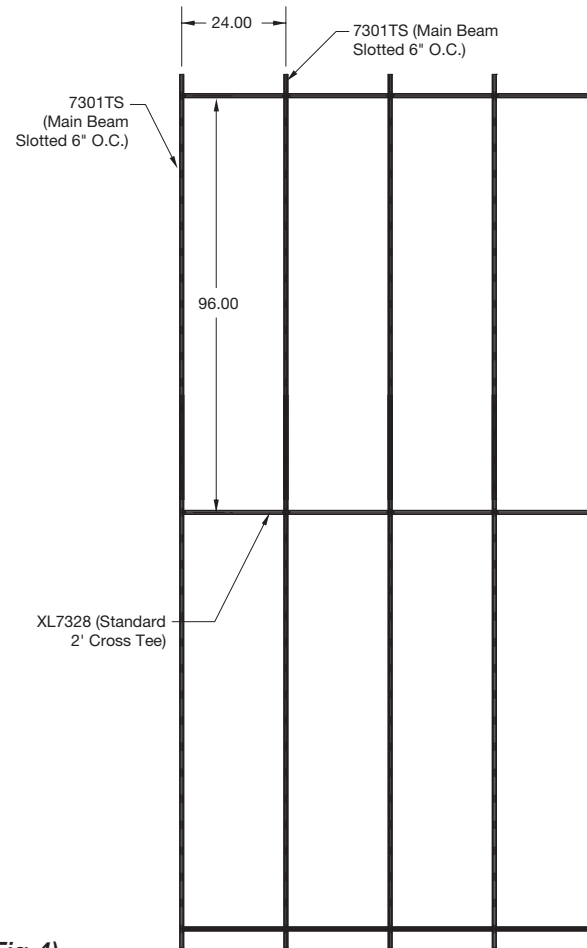

**(Fig 4)**

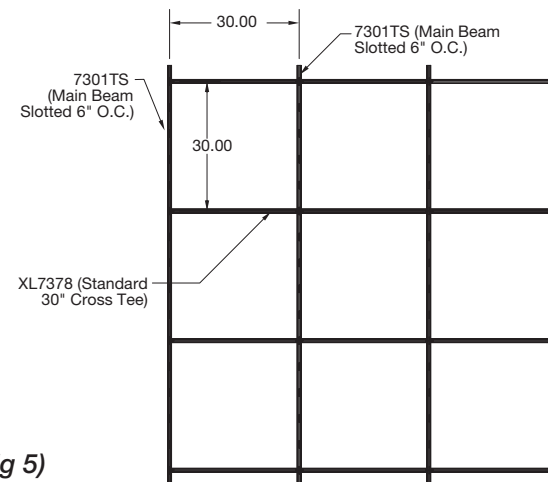

**(Fig 5)**

Hangers and bracing are to comply with all local code requirements. The suspension system shall be properly installed and leveled using not less than 12 gauge galvanized steel wire. Suspension system installation shall conform to ASTM C636 requirements.

**The suspension system for all panel sizes must be leveled to within 1/4" in 10' and must be square to within 1/16" in 2'. 90° Alignment Clips (item 7134) can be used to assure the grid system meets the squareness requirement.**

**2.5** Location of the first main beam shall be as detailed on the reflected ceiling plan, so as to provide borders that are equal in size and greater than 1/2 of the full panel width. Pay close attention when cutting this first main beam to length; make sure that the slots in the main beam are in the correct position to accept the springs attached to the panel size being installed.

**2.6** Perimeters are trimmed with item 7125 Box Molding attached with appropriate fasteners. The suspension system will rest on the upper 2" flange of the box molding and the panel edges will rest on the bottom 1" flange. *(Fig 6)*

**2.7** Cut edges are held down against the molding by inserting a 7126 Spreader Hold Down into the molding, between the upper and lower flanges, over each cut panel. The 7126 Spreader Hold Down is 10.625" long, so use the appropriate amount of hold downs for the panel edge dimension. *(Fig 7)*

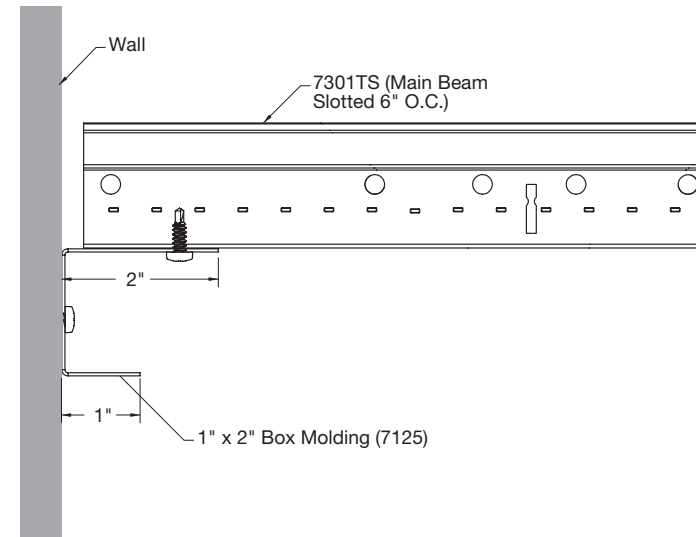

*(Fig 6)*

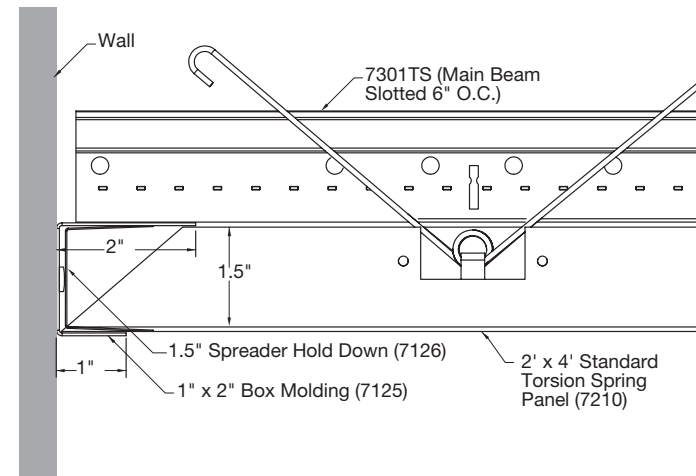

*(Fig 7)*

**2.8 Floating Perimeters:** The suspension layout for floating perimeters or cloud applications should be the same as what is detailed in Sections 2.1 - 2.4 for the specific panel sizes. Please note that main beams and cross tees need to be in place around the entire perimeter so perimeter trim can be attached to the suspension system. Item 7147 is an extruded perimeter trim available in White, Silver, Gun Metal, and Black. Item 7131 is a formed perimeter trim available in Lacquer Mill, Satin Anodized, and Brushalume finishes. The perimeter trim is designed for straight perimeters and should not be curved. *(Figs 8-11)*

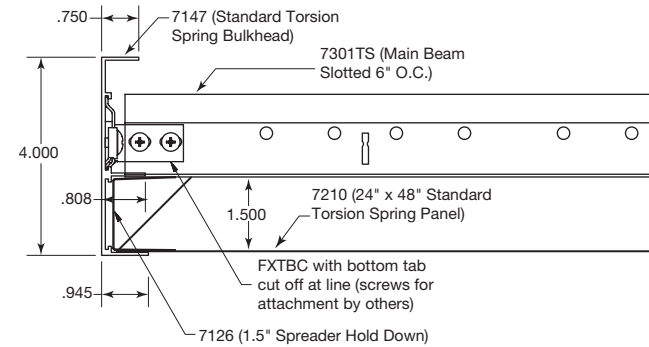

*Detail for Field Cut Panels*

*(Fig 10)*

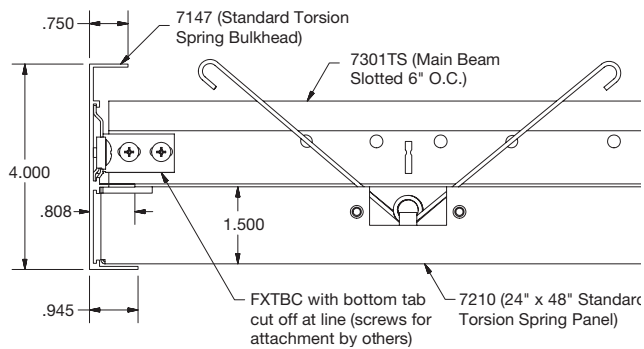

*Extruded Perimeter Trim (Item #7147) Detail for Full Size Panels*

*(Fig 8)*

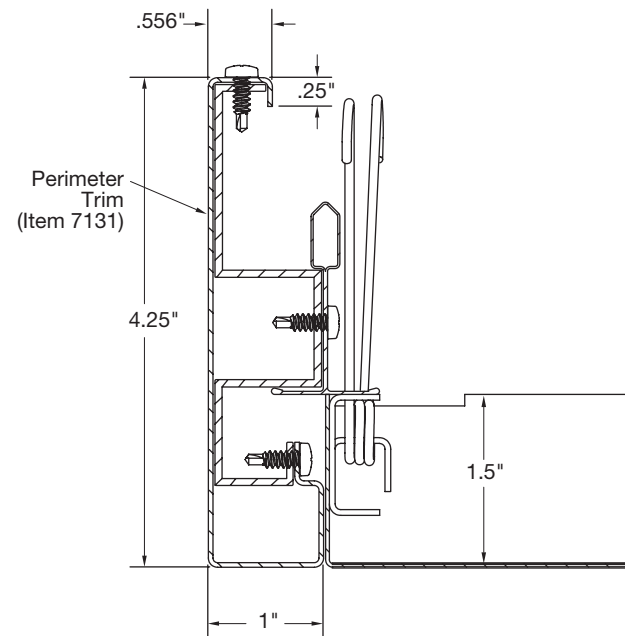

*Formed Perimeter Trim (Item #7131)*

*(Fig 11)*

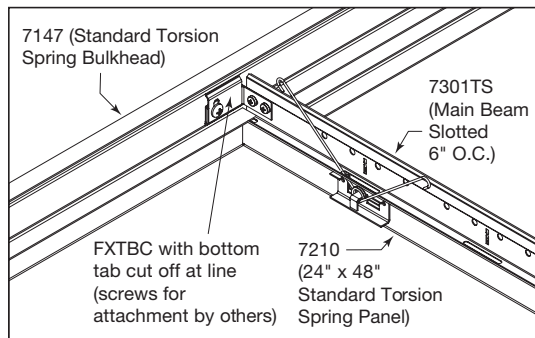

*(Fig 9)*

### 3.0 PANEL INSTALLATION

Panels are mechanically directional. Two opposite sides feature a set amount of springs that engage the main beam and retain the panel.

**3.1** Align the springs with the slots in the flange of the main beam or cross tee. Compress the spring and insert it into the corresponding slot. Follow this same process for each spring on the panel. Then press up into place with the palm of the hand. The springs should spread apart in the slots of the grid and seat the panel into place. (Figs 12-14)

(Fig 12)

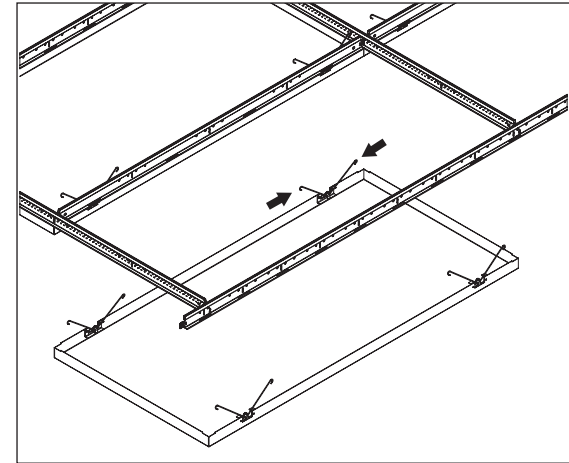

STEP 2

(Fig 13)

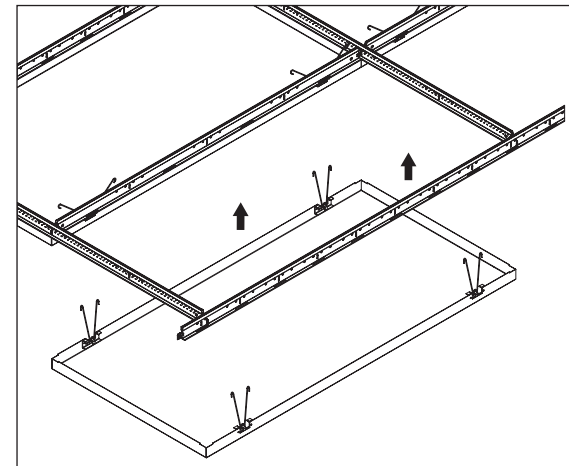

STEP 3

(Fig 14)

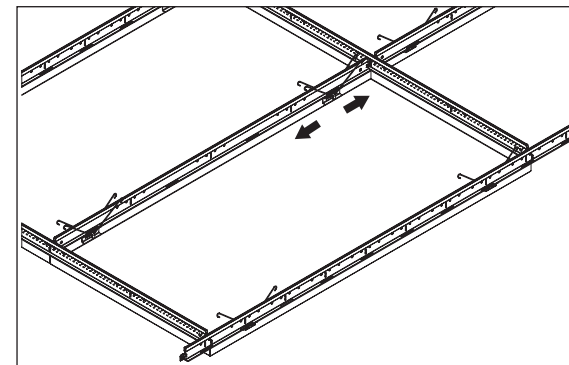

STEP 4

### 3.2 Cut Panels

Cut panels should never occur within the field of the ceiling. All ceiling mounted services must either replace a full panel, install into a hole that is cut into a panel, or be mounted through the face of a panel.

**3.2.1** MetalWorks™ panels can be cut to size at the perimeters using standard tools and methods for aluminum panels.

- For straight cuts, it is recommended to use a metal cutting circular saw with a non-ferrous metal cutting blade (consult blade manufacturer for specific recommendation).
- For curved cuts, it is recommended to use a jig saw with an aluminum cutting blade or electric metal cutting shears.
- The quality of the cut can impact the flatness of the cut edge, which may require additional Spreader Hold Downs or Effects™ Hold-Down Clips (FXSPTHDC).

**3.2.2** When BioAcoustic™ (item 5823) or fiberglass (item 8200T10) infill is used, it also must be cut to size. This is best done with a large pair of shears or scissors. Reseal the poly bag with packing tape prior to installation.

### 3.3 Panel Removal

All panels are removable without moving up into the plenum.

**3.3.1** The Hook Panel Removal Tool, item 7129, for perforated or unperforated panels, is inserted into the joint between two panels. Make sure you insert the tool within 1" from a panel intersection to grab the correct part of the panel. Twist the tool 90 degrees to hook the top of the panel. Then pull the tool downward, slowly, until the spring catches on the flange of the grid and can be seen. Now that the spring has become accessible, push the spring together, slide it down through the slot, and pull down gently to release the panel from the main beam. (Figs 15-18)

The Suction Panel Removal Tool (item 7130) is for unperforated panels only. Place the device on the corner edge of the panel and gently pull down until the spring is accessible. Push the spring together and pull down gently to release the panel from the main beam.

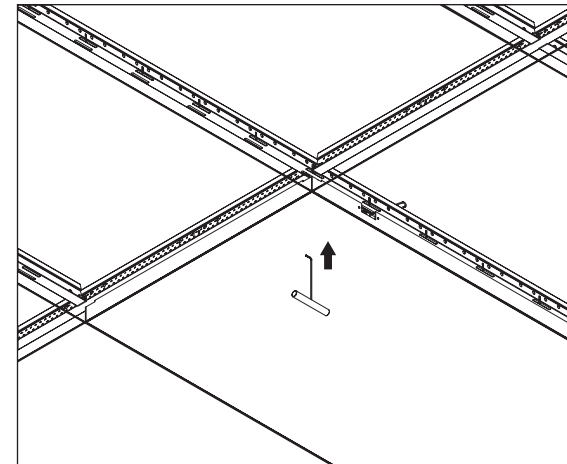

(Fig 15)

STEP 1

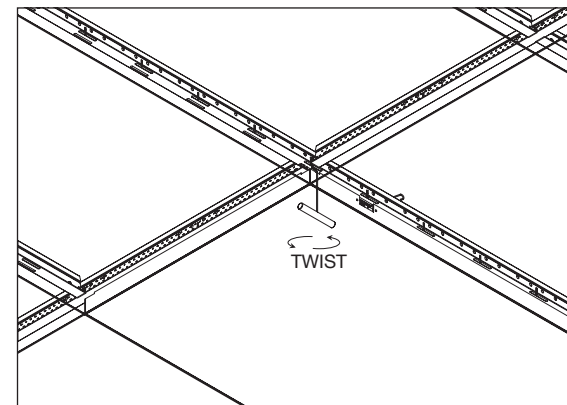

(Fig 16)

STEP 2

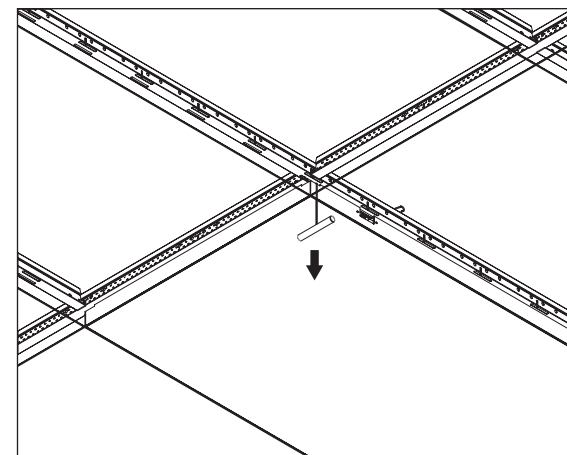

(Fig 17)

STEP 3



**3.3.2** Adjacent panels may be removed from the same row of main beams without further use of the tool.

**3.3.3** The panel is designed to provide swing-down accessibility. Using one of the above methods, pull the panel down until all springs catch on the flange of the grid and can be seen. Disengage all springs from one side of the panel. This will allow the panel to swing down and be supported by the springs on the opposing side. Be sure to 'guide' the panel into its resting position to avoid introducing unnecessary forces into the panel or system. (Fig 19)

## 4.0 SEISMIC INSTALLATION

MetalWorks™ Torsion Spring has been engineered and tested for application in all seismic areas.

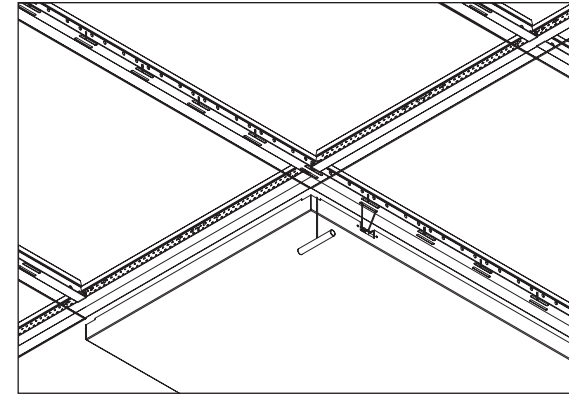

(Fig 18)

STEP 4

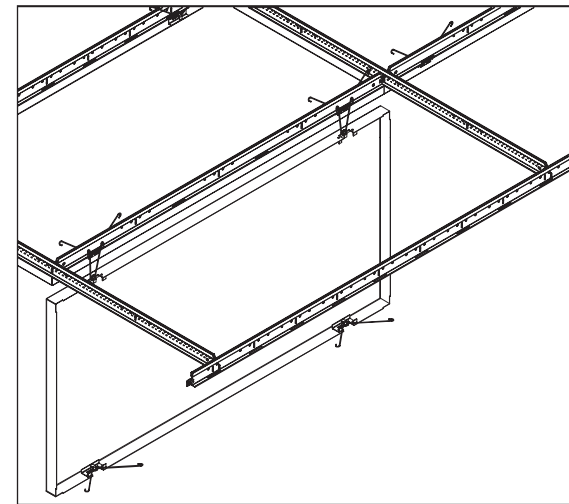

(Fig 19)

### MORE INFORMATION

For more information, or for an Armstrong Ceilings representative, call 1 877 276-7876.

For complete technical information, detail drawings, CAD design assistance, installation information, and many other technical services, call TechLine customer support at 1 877 276-7876 or FAX 1 800 572-TECH.

All trademarks used herein are the property of AWI Licensing LLC and/or its affiliates.  
© 2022 AWI Licensing Company Printed in the United States of America

BPLA-297833-422

**Armstrong**<sup>®</sup>  
CEILING & WALL SOLUTIONS