

# METALWORKS™ Torsion Spring Shapes

## Assembly and Installation Instructions

Item No.	Description	Ordered Separately/ Included with	Required for Install	Sold by the	Pcs/ Ctn
<b>2D Shapes and Perimeter Solutions on 24" x 24" Grid</b>					
BP8216 T01	MW Torsion Spring Shapes 45° Right-Triangle with 24" Base	Ordered Separately	Based on Design	500 SF min.	Bulk
BP8216 T02	MW Torsion Spring Shapes 60° Right-Triangle Left with 48" Base	Ordered Separately	Based on Design	500 SF min.	Bulk
BP8216 T03	MW Torsion Spring Shapes 60° Right-Triangle Right with 48" Base	Ordered Separately	Based on Design	500 SF min.	Bulk
BP8216 P01	MW Torsion Spring Shapes 45° Parallelogram-Left with 24" Base	Ordered Separately	Based on Design	500 SF min.	Bulk
BP8216 P02	MW Torsion Spring Shapes 45° Parallelogram-Right with 24" Base	Ordered Separately	Based on Design	500 SF min.	Bulk
BP8216 P03	MW Torsion Spring Shapes 30° Parallelogram-Left with 24" Base	Ordered Separately	Based on Design	500 SF min.	Bulk
BP8216 P04	MW Torsion Spring Shapes 30° Parallelogram-Right with 24" Base	Ordered Separately	Based on Design	500 SF min.	Bulk
BP8216 P05	MW Torsion Spring Shapes 60° Parallelogram-Left with 24" Base	Ordered Separately	Based on Design	500 SF min.	Bulk
BP8216 P06	MW Torsion Spring Shapes 60° Parallelogram-Right with 24" Base	Ordered Separately	Based on Design	500 SF min.	Bulk
BP8216 P07	MW Torsion Spring Shapes 45° Parallelogram-Left with 48" Base	Ordered Separately	Based on Design	500 SF min.	Bulk
BP8216 P08	MW Torsion Spring Shapes 45° Parallelogram-Right with 48" Base	Ordered Separately	Based on Design	500 SF min.	Bulk
BP8216 Z01	MW Torsion Spring Shapes 45° Trapezoid with 72" Base	Ordered Separately	Based on Design	500 SF min.	Bulk
BP8216 R01	MW Torsion Spring Shapes 24" x 24" Square	Ordered Separately	Based on Design	500 SF min.	Bulk
BP8216 R02	MW Torsion Spring Shapes 24" x 48" Rectangle	Ordered Separately	Based on Design	500 SF min.	Bulk
BP8216 R03	MW Torsion Spring Shapes 24" x 72" Rectangle	Ordered Separately	Based on Design	500 SF min.	Bulk
BP8216 R04	MW Torsion Spring Shapes 24" x 96" Rectangle	Ordered Separately	Based on Design	500 SF min.	Bulk
<b>3D Shapes and Perimeter Solutions on 24" x 24" Grid</b>					
BP8219 T01	MW Torsion Spring Shapes 45° Triangle 3D-01 24" Base	Ordered Separately	Based on Design	500 SF min.	Bulk
BP8219 T02	MW Torsion Spring Shapes 45° Triangle 3D-02 24" Base	Ordered Separately	Based on Design	500 SF min.	Bulk
BP8219 T03	MW Torsion Spring Shapes 45° Triangle 3D-03 24" Base	Ordered Separately	Based on Design	500 SF min.	Bulk
BP8219 R01	MW Torsion Spring Shapes 30" x 30" Square	Ordered Separately	Based on Design	500 SF min.	Bulk
<b>Suspension System for 24" Module</b>					
7891	12-gauge Hanger Wire	Ordered Separately	Yes	Bundle	
7301TS	Prelude® XL® 12' HD Main Beam – slotted for Torsion Spring	Ordered Separately	Yes	Ctn	20
XL7341TS	Prelude XL 4' Cross Tee – slotted for Torsion Spring	Ordered Separately	Required	Ctn	60
XL8320TS	Prelude XL 2' Cross Tee – slotted for Torsion Spring	Ordered Separately	Required	Ctn	60
XL7341	Prelude XL 4' Cross Tee	Ordered Separately	Optional	Ctn	60
XL8320	Prelude XL 2' Cross Tee	Ordered Separately	Optional	Ctn	60
<b>Integration Solutions for 24" Module Technical Zones</b>					
BP8266 R01	MW Torsion Spring Shapes 4" x 48" Panel	Ordered Separately	Based on Design	500 SF min.	Bulk
BP8266 R02	MW Torsion Spring Shapes 4" x 72" Panel	Ordered Separately	Based on Design	500 SF min.	Bulk
BP8266 R03	MW Torsion Spring Shapes 6" x 48" Panel	Ordered Separately	Based on Design	500 SF min.	Bulk
BP8266 R04	MW Torsion Spring Shapes 6" x 72" Panel	Ordered Separately	Based on Design	500 SF min.	Bulk
BP8266 C01	MW Torsion Spring Shapes 4" x 48" Panel with Cut Out for 2" Linear Light	Ordered Separately	Based on Design	500 SF min.	Bulk
BP8266 C02	MW Torsion Spring Shapes 6" x 48" Panel with Cut Out for 4" Linear Light	Ordered Separately	Based on Design	500 SF min.	Bulk

continued

continued

Item No.	Description	Ordered Separately/ Included with	Required for Install	Sold by the	Pcs/ Ctn
<b>2D Hexagonal Shapes and Perimeter Solutions on 15" x 30" Grid</b>					
BP8217 H01	MW Torsion Spring Shapes Hexagon 30"	Ordered Separately	Based on Design	500 SF min.	Bulk
BP8217 H02	MW Torsion Spring Shapes Half Hexagon 30"	Ordered Separately	Based on Design	500 SF min.	Bulk
BP8217 H03	MW Torsion Spring Shapes Hexagon Perimeter 30"	Ordered Separately	Based on Design	500 SF min.	Bulk
BP8217 R01	MW Torsion Spring Shapes 30" x 30" Square	Ordered Separately	Based on Design	500 SF min.	Bulk
<b>Suspension System Components for 30" Module</b>					
7891	12-gauge Hanger Wire	Ordered Separately	Yes	Bundle	
7301TS	Prelude® XL® 12' HD Main Beam – slotted for Torsion Spring	Ordered Separately	Yes	Ctn	20
XL7378TS	Prelude XL 30" Cross Tee – slotted for Torsion Spring	Ordered Separately	Required for Hexagon Panels	Ctn	60
XL7378	Prelude XL 30" Cross Tee		Optional for Hexagon Panels	Ctn	60
<b>Integration Solutions for 24" Module Technical Zones</b>					
BP8267 R01	MW Torsion Spring Shapes 4" x 15" Panel	Ordered Separately	Based on Design	500 SF min.	Bulk
BP8267 R02	MW Torsion Spring Shapes 4" x 18" Panel	Ordered Separately	Based on Design	500 SF min.	Bulk
BP8267 R03	MW Torsion Spring Shapes 4" x 36" Panel	Ordered Separately	Based on Design	500 SF min.	Bulk
BP8267 R04	MW Torsion Spring Shapes 6" x 15" Panel	Ordered Separately	Based on Design	500 SF min.	Bulk
BP8267 R05	MW Torsion Spring Shapes 6" x 18" Panel	Ordered Separately	Based on Design	500 SF min.	Bulk
BP8267 R06	MW Torsion Spring Shapes 6" x 36" Panel	Ordered Separately	Based on Design	500 SF min.	Bulk
BP8267 R07	MW Torsion Spring Shapes 4" x 30" Panel	Ordered Separately	Based on Design	500 SF min.	Bulk
BP8267 R08	MW Torsion Spring Shapes 6" x 30" Panel	Ordered Separately	Based on Design	500 SF min.	Bulk
BP8267 C01	MW Torsion Spring Shapes 4" x 36" Panel with Cutout for 2" Linear Light	Ordered Separately	Based on Design	500 SF min.	Bulk
BP8267 C02	MW Torsion Spring Shapes 6" x 36" Panel with Cutout for 4" Linear Light	Ordered Separately	Based on Design	500 SF min.	Bulk
<b>Perimeter Trim</b>					
7125	Box Molding	Ordered Separately	Based on Layout	Ctn	10
7126	Spreader Hold Down	Ordered Separately	Based on Layout	Ctn	10
7147	Torsion Spring Perimeter Trim (Extruded)	Ordered Separately	Based on Layout	Ctn	6
Varies	Axiom® Classic	Ordered Separately	Based on Layout	Pc	
7239	Adjustable Trim Clip	Ordered Separately	Required for Axiom	Ctn	50
AXSPTHDC	Axiom® Serpentina® Hold Down Clip	Ordered Separately	Based on Design	Pc	
8218	MW Torsion Spring Shapes Linear Trim	Ordered Separately	Based on Design	Ctn	10
	Metal Framing Screws (see instructions for application details)	By Others	Yes		
<b>Accessories</b>					
7129	MW Torsion Spring Hook Access Tool	Ordered Separately	Required for Access	Pc	1
7130	MW Torsion Spring Suction Access Tool	Ordered Separately	Required for Access	Pc	1
8112C02T06W37BL	Spare Gasket	Ordered Separately	Optional	Roll	100 LF

Reference Price List for min. order quantities.  
See separate product Data Pages for additional information.

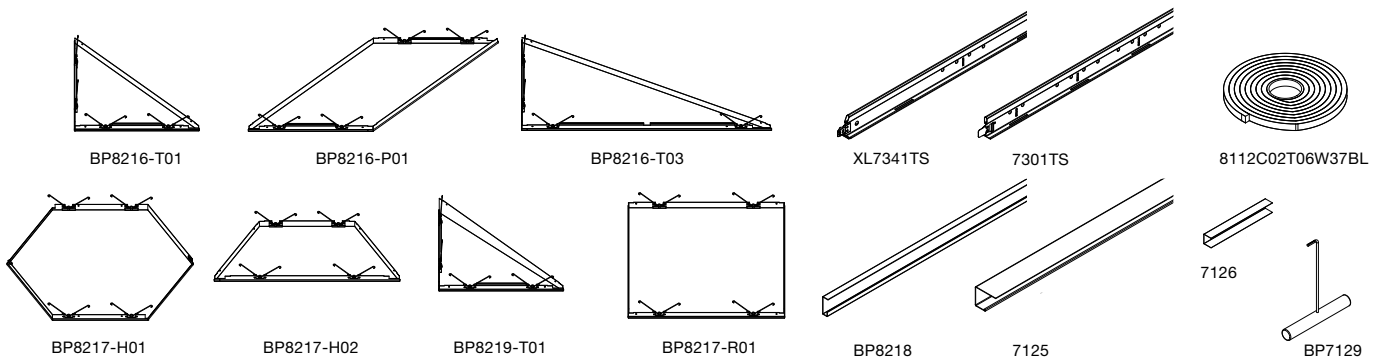

## 1. GENERAL

### 1.1 Product Description

METALWORKS™ Torsion Spring Shapes panels are made from aluminum with a factory-applied polyester coating, and designed to be suspended from Slotted Prelude® XL® 15/16" suspension system in a standard 90-degree layout. The 1.5" deep panels mount to the face of the grid system using springs that insert through the slotted grid. All panels are wrapped in a highly durable gasket that ensures even spacing between panels. METALWORKS Torsion Spring Shapes panels are available in multiple sizes of triangles, parallelograms, squares, and rectangles that can be mixed and matched to create interesting and dynamic patterns in the ceiling. The 30" hexagon panels are available to install with perimeter solutions. Torsion Spring Shapes panels for technical zones provide a great solution for visually compatible lighting, plumbing, and HVAC integration. Three 3D triangle panels can be installed in different combinations for multiple, exciting ceiling layouts.

These panels are smooth and available in four standard colors: Whitelume (WHA), Silverlume (SIA), Gun Metal (MYA), and Black (BL). Contact ASQuote@armstrongceilings.com to inquire about custom colors. Options include unperforated (M1) panels or acoustical panels with M21 perforation. Please note, unlike many Armstrong METALWORKS products, this perforation pattern goes the entire face of the panel (no unperforated border).

### 1.2 Storage and Handling

Ceiling panels shall be stored in a dry interior location and shall remain in their original crate prior to installation to avoid damage. Proper care should be taken when handling to avoid damage or soiling. **NOTE:** each panel has a clear protective film on the surface of the panel to protect from dirt and scratching, as well as to indicate any directionality in the panel as noted by small arrows. The film should be removed after installation is complete.

### 1.3 Site Conditions

Areas to receive ceilings shall be free of construction dust and debris. Panels should only be installed in closed and acclimatized buildings. The METALWORKS Torsion Spring Shapes panels are not intended for exterior applications, where standing water is present, or where moisture will come in direct contact with the ceiling.

### 1.4 Fire Performance

METALWORKS Shapes panels are tested to ASTM E84 and CAN/ULC S102 surface burning characteristics. Flame Spread Index 25 or less. Smoke Developed Index 50 or less.

### 1.5 Safety Considerations

#### Working with Aluminum Products:

Product arrives in a crate; make arrangements for safe handling.

Edges of metal parts can be sharp. Handle metal carefully to avoid injury. Always wear safety glasses and cut-resistant gloves when handling or cutting metal. When cutting panels, exposed raw edges of metal can be a safety hazard. Cutting tools should be appropriate for aluminum. Improper cutting equipment could damage or dent the metal panels and cause fit issues with the grid system.

Torsion Springs located on each panel come in a "closed" position. Use caution when unwinding the springs to avoid finger injuries. Panels are installed by compressing the spring,

inserting the spring through the slot in the grid system and carefully releasing the spring. Use caution when releasing the spring for installer's safety, as well as for potential damage to the panel face.

**⚠ Item number 8217H01 contains Rare Earth Neodymium Magnets. While these magnets are commonly used in commercial applications, individuals with pacemakers, ICDs, or other implanted medical devices must use caution as magnets can impact performance of these devices. Consult physician for specific details.**

### 1.6 Warranty

The METALWORKS Torsion Spring Shapes system has been tested based on the installation guidelines described in this document. The warranty will be voided if you do not follow instructions and guidelines.

### 1.7 Plenum

**1.7.1** Installation of METALWORKS Torsion Spring Shapes panels requires a minimum of 5" above the grid face.

**NOTE:** Due to the 1.5" depth of the flat panels, the above-finished-floor height of the ceiling will be 6.5" below the lowest ceiling plenum obstruction.

**1.7.2** Independent support of MEP devices is required. There must not be weight from any lights, diffusers, speakers, or similar devices supported by aluminum panels or the suspension system.

### 1.8 Cleaning

An abrasive or strong chemical detergent should not be used. A mild detergent diluted in warm water, applied with a soft cloth, rinsed, and wiped off with a chamois will maintain the panels in good condition. Oily or stubborn stains, if not removed by washing, can be wiped with products like Fantastik®, but care is necessary to avoid affecting the gloss level of the paint finish. The protective film that comes on the panels may leave a slight sticky residue once removed, especially around the perimeter of the panels. Fantastik and a micro-fiber cloth are effective at removing the residue.

## 2. DESIGN AND INSTALLATION CONSIDERATIONS

### 2.1 Design Layout Guidelines:

#### 2.1.1 Suspension System:

This system is designed to allow various panel layouts utilizing multiple panel shapes within standard grid layouts. All grid layouts are constructed with slotted Prelude® XL® grid set at 90° angles. Different grid layouts (e.g. 24" x 24", 15" x 30" cross-hatched) are used for different panel types (2D/3D, Hexagon). Refer to your job-specific drawings for panel layout. See section 4.3 for grid layout guidelines.

#### Standard 24" x 24" Prelude Slotted Grid System

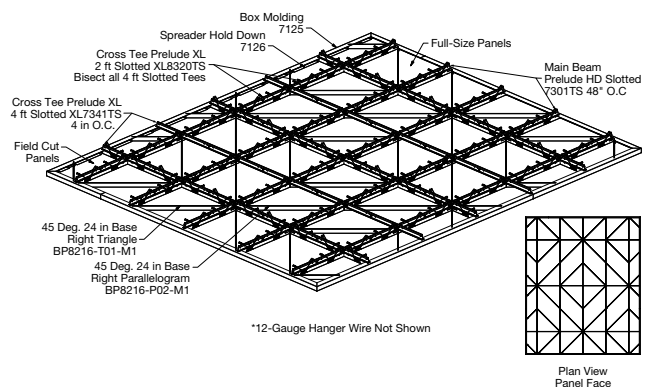

## Standard 15" x 30" Prelude Slotted Grid System

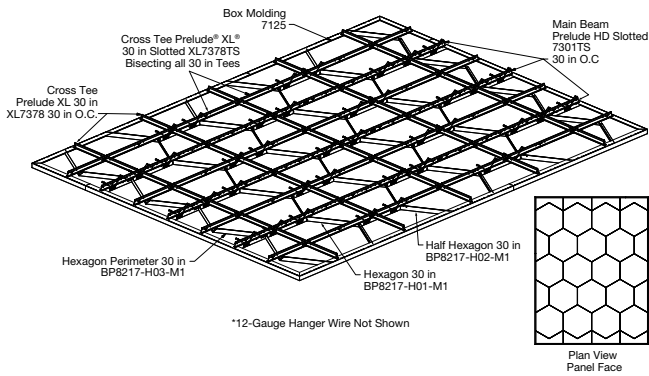

### 2.1.2 Panels

METALWORKS™ Torsion Spring Shapes has groups of panels that are designed to coordinate with each other. Refer to the online pattern gallery filtered by the Torsion Spring Product System for panel design layout examples.

Each group must be installed following these layout rules:

- For panels that fit within the 2' x 2' module system (Any panel that has a 24", 48", 72", or 96" base length dimension):
  - All panel corners must be located at grid intersections. The suspension system layout must match the spring locations on the panels.

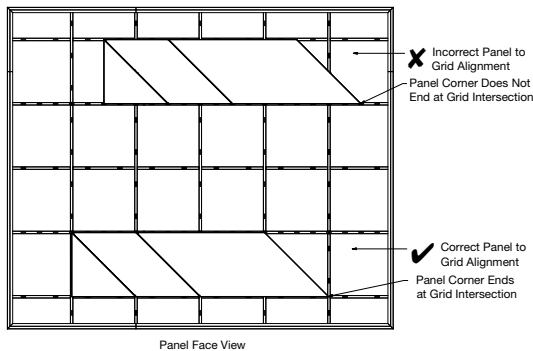

- All panel springs must be engaged in slots within the grid.
- Panel corner angles should equal 90° or 180°. (For example, a shape with a 30-degree angle will work next to a shape that has a 60-degree or 150-degree angle).

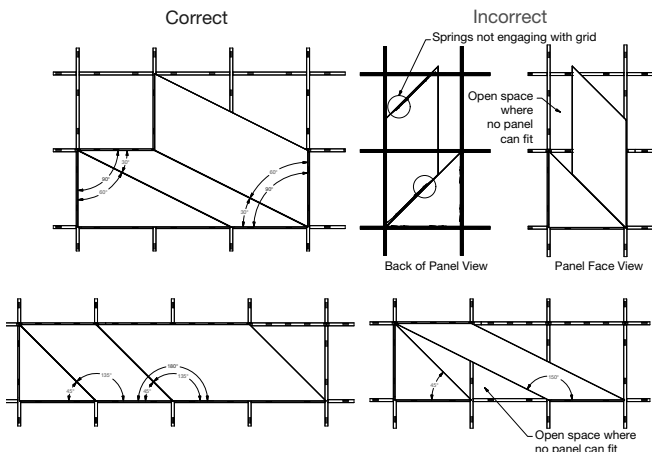

- Square and rectangle panels can be optionally used at the perimeters of an installation.

## Hexagon panels (for a 15" x 30" cross-hatched grid layout):

- Hexagon panels can only be installed in one layout pattern, where all springs run parallel with the slotted grid components.
- The Half Hexagon (BP8217 H02) and Hexagon Perimeter (BP8217 H03) panels can be used at the perimeters of an installation to square off the borders.

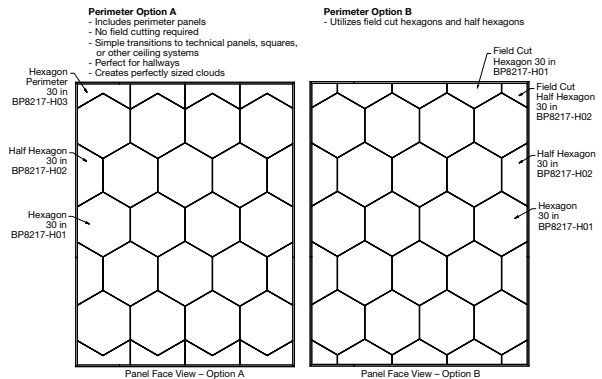

### 2.2 Directionality

**2.2.1 Panel finishes:** Panels are available in four standard colors: Whitelume (WHA), Silverlume (SIA), Gun Metal (MYA), and Black (BL). Silverlume and Gun Metal have slight directionality that might be visible in certain low-raking light conditions. Upon receipt, panels will have directionality marked by arrows on clear protective film. Do not remove film until the panels are fully installed in the ceiling system.

**2.2.2 Panel shapes:** All panels must be installed in a specific orientation in order to match the architectural ceiling plans (by others). The specified layout design will dictate the direction of the panels.

### 2.3 Panel Offset

#### 2D Panels:

The finish face of all 2D panels drops 1-1/2" below the face of the grid.

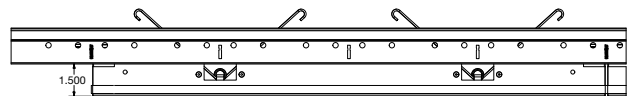

The installed height of components that interface with these ceiling panels, such as sprinkler heads and light fixture trim rings, will have to be adjusted to accommodate this 1-1/2" offset.

#### 3D Panels:

3D triangle panels have a 4" drop on one or two corners of the panel and a 1-1/2" drop on the remaining corners. Installations must follow these layout rules to avoid visibility of tooling cutouts:

- Corners with a 4" drop must only intersect with other 4" drop corners.
- Corners with a 4" drop cannot interface with perimeters of the installation.
- 2D panels should be used to transition an installation with 3D panels into the perimeter trim or technical zones for fixtures.

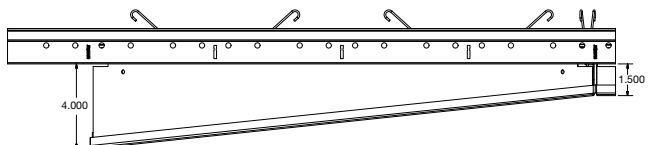

### Incorrect 2D to 3D Panel Placement

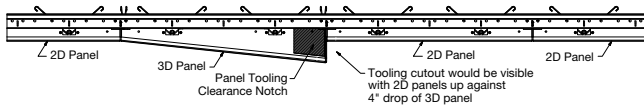

### Correct 2D to 3D Panel Placement

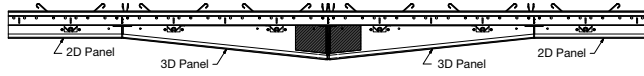

## 2.4 Panel Reveal

All METALWORKS™ Torsion Spring Shapes panels have an 1/8" reveal that is maintained with durable foam tape (gasket) around the panel edges. This reveal is designed to accentuate panel shapes while helping to account for tolerances within an installation.

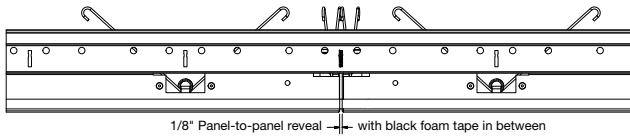

## 2.5 Plenum

**2.5.1** METALWORKS Torsion Spring Shapes panels are downward accessible and do not need to enter the plenum during installation or access.

**2.5.2** When panels are in the installed position the springs protrude 1.5" above the top of the grid.

## 2.6 Sprinklers

**2.6.1** 2D METALWORKS Torsion Spring Shapes panels drop 1-1/2" below the face of the grid. Sprinkler heads need to be installed at the proper height to accommodate this drop.

**2.6.2** Sprinkler integration in 3D panels must be approved by a Fire Protection Engineer and/or local building code officials due to the impact of the spray pattern and panel geometry.

## 2.7 Approximate System Weight

**2.7.1** Overall system weight can be calculated with the weights listed below:

METALWORKS Torsion Spring Shapes panels weigh approximately 0.98 lbs/SF.

**2.7.2** The weight of the suspension system ranges between 0.2 – 0.4lbs/SF.

**2.7.3** Hanger connections to the structure must follow the manufacturer's instructions and referenced code. Average system weight per square foot will vary based on panel types and layout.

## 2.8 Accessibility

METALWORKS Torsion Spring Shapes panels are downward accessible and do not need to enter the plenum during installation or access. All non-cut panels are 100% downward accessible.

Full-size panels without penetrations are accessible. Border panels may not be accessible based on the perimeter interface and the installation method.

## 2.9 Perimeters

### 2.9.1 2D Panels:

Installed in the same fashion as traditional Torsion Spring panels. See section 4.5.

**2.9.2** Hexagon installations: The Half Hexagon (BP8217 H02) and Hexagon Perimeter (BP8217 H03) are intended for use to fill voids at the perimeters of Hexagon installations. These panels can be used as full-size perimeter panels or for cut perimeter panels.

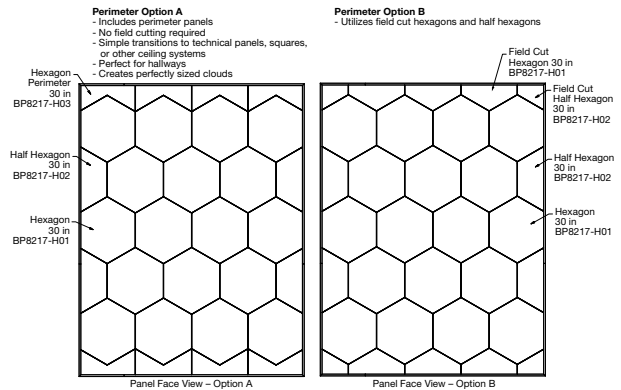

### 2.9.3 3D Installations:

3D panel installations must be surrounded by 2D panels to integrate into perimeters. The 2D panels act as a transition to ensure a 1-1/2" panel offset from the grid that the perimeter trims are designed for. See section 7.5 for additional details.

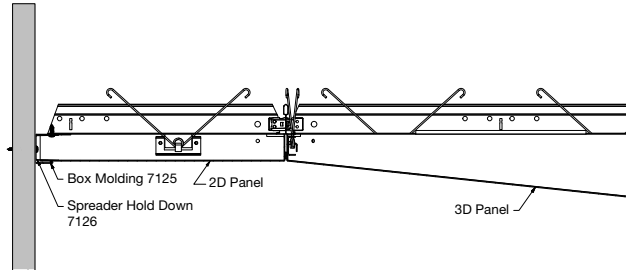

## 2.10 Fixture Integration

Panel face will not necessarily align with suspension system parts. In certain patterns, grid intersections may intersect directly behind the center of a panel, so standard light fixtures will require modifications to grid layout. For details on fixture integration, see section 8.

## 3. ACCESSORIES

### 3.1 Suspension System Accessories

#### METALWORKS Torsion Spring Shapes Linear Trim (8218)

The METALWORKS Torsion Spring Shapes Linear Trim can be used to integrate continuous linear lighting. See section 8.3 for installation guidance.

### 3.2 Panel Accessories

#### 3.2.1 Gasket as a separate item

1/16" Gasket is applied around all edges of the panels. If additional gasket is required, it can be ordered by the 100 LF roll through the Armstrong Customer Focus Center (Item BP8112C02T06W37BL).

### 3.2.2 Access Tools:

All panels are removable without moving up into the plenum. There are two recommended tools that can be used to remove a panel or to gain access into the plenum:

#### 3.2.2.1 Hook Access Tool (7129)

The Hook Panel Removal Tool, item 7129, for perforated or unperforated panels, is inserted into the joint between the gasket of two panels. Easiest insertion point is the corner of the panel. Twist the tool 90° to hook the top of the panel. Then pull the tool downward, slowly, until the spring catches on the flange of the grid and can be seen. Now that the spring has become accessible, push the spring together, slide it down through the slot, and pull down gently to release the panel from grid. See section 7.7.2 for further instructions. When removing a hexagon panel, refrain from using the pull down tool at the two opposite corner tips where the magnets are located. This is at the center of the panel and pulling from this location could cause the panel to bend and become damaged.

#### 3.2.2.2 Suction Access Tool (7130)

The Suction Access Tool (item 7130) is for unperforated panels only. Place the device on the corner edge of the panel and gently pull down until the spring is accessible. Push the spring together and pull down gently to release the panel from the main beam. Refrain from using the suction cup tool at the opposite center corners of the hexagon panel.

## 4. SUSPENSION SYSTEM – WALL TO WALL

The requirements listed here represent the manufacturer's minimum acceptable installation recommendations, and may be subject to additional requirements established by the local authority having jurisdiction. See section 9 for grid requirements in seismic installations.

- All installations should follow ASTM C636.
- All references to suspension component duty ratings are per ASTM C635 and E3090.

### 4.1 System Components

#### Main Beams:

- METALWORKS™ Torsion Spring Shapes are installed on Prelude® XL® Heavy-Duty main beams that are pre-slotted 6" O.C. (7301TS).

#### Slotted Cross Tees:

- Slotted Prelude cross tees are used to give flexibility in panel layout. These cross tees have XL end details and install just like standard Prelude cross tees.

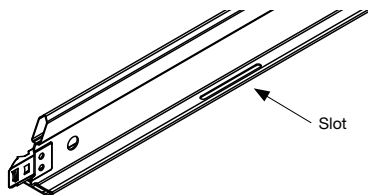

#### Standard (non-slotted) Cross Tees:

Standard Prelude cross tees can be used to replace Slotted Prelude cross tees when the panel layout does not require slots for springs at that cross tee location. Only the specific item numbers listed below can be used with METALWORKS Torsion Spring Shapes installations:

- For the 2' x 2' layout: XL7341 (4' cross tee), and XL8320 (2' cross tee)
- For the 30" layout: XL7378 (30" cross tee)

### 4.2 Suspension Rules

Hangers and bracing are to comply with all local code requirements in addition to:

- Main beams must be installed at no more than 48" O.C.
- Hanger wires must be installed no more than 48" O.C. along the mains.

### 4.3 Layouts

#### 2' x 2' Layout

A standard 2' x 2' grid layout with slotted mains, slotted 4' cross tees, and slotted 2' cross tees is recommended to achieve maximum design adaptability within the system. This grid layout will accommodate all METALWORKS Torsion Spring Shapes panels except for the Hexagon panel group. The 2' x 2' grid layout is required for system stability regardless of panel layout. Standard (non-slotted) cross tees can be substituted for slotted cross tees following the rules in section 4.1.

Slotted Prelude Main beams (7301TS) installed at 48" O.C., with Slotted 4' Prelude cross tees perpendicular to the main beams at 2' O.C., and Slotted 2' Prelude cross tees spanning the midpoints of the 4' cross tees.

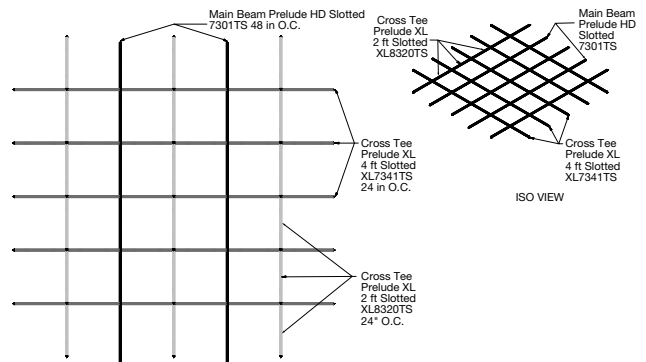

#### 15" x 30" Cross-Hatched Layout

- A 15" x 30" cross-hatched grid layout is required for installation of the 30" Hexagon panels.

Slotted Prelude Main beams (7301TS) installed at 30" O.C., with standard 30" Prelude cross tees perpendicular to the main beams at 30" O.C., and Slotted 30" Prelude cross tees spanning the midpoints of the standard 30" cross tees.

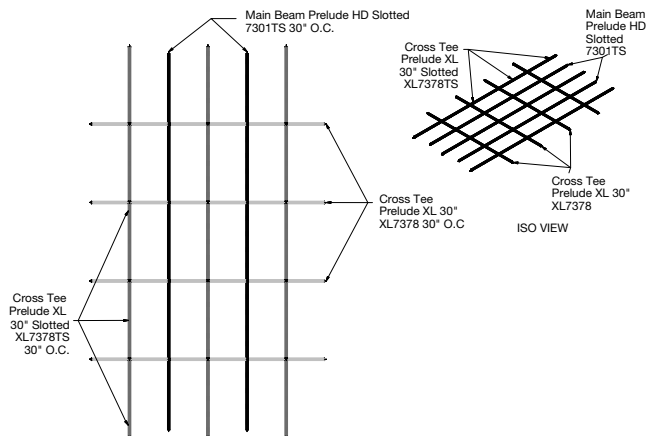

#### 4.4 Squaring and Leveling the grid

The suspension system for all panel sizes must be leveled to within 1/4" in 10' and must be square to within 1/16" in a 4' x 4' opening.

#### 4.5 Wall-to-wall Perimeter Attachment to Box Molding

Perimeters are trimmed with item 7125 Box Molding to which the suspension system can be attached with metal framing screws (provided by contractor). The suspension system will rest on the upper 2" flange of the box molding and the panel edges will rest on the bottom 1" flange.

Cut edges are held down against the molding by inserting a 7126 Spreader Hold Down into the molding, between the upper and lower flanges, over each cut panel. The 7126 Spreader Hold Down is 10.625" long, so use the appropriate amount of hold downs for the panel edge dimension.

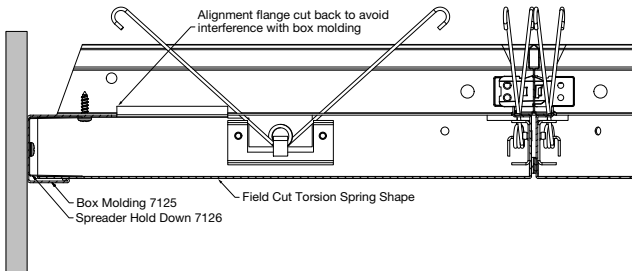

### 5. FLOATING PERIMETERS / TRIM FOR DISCONTINUOUS CEILINGS

Installations that include floating perimeters can be trimmed with Torsion Spring Perimeter Trim (7147) or Axiom® Classic trim. When using Axiom, the Adjustable Trim Clip (7239) must be used to accommodate the 1-1/2" panel face offset. Refer to the product specific installation instructions for Axiom Classic trim for full instructions.

#### 5.1 Torsion Spring Perimeter Trim (7147)

##### 5.1.1 Suspension Rules

In consideration of the suspension rules below, the trim can be independently supported to facilitate proper layout.

When the trim is not independently supported, the following suspension rules must be followed:

- All splices (including corners) require supporting grid members within 24" on each side of the splice. Where this is not possible the trim will require supplemental support directly from structure.
- The trim must be connected to supporting grid members no more than 48" O.C..
- All grid supporting the trim must have a wire at a max distance from the trim that is not greater than half the length of the grid member, up to a max of 12" (up to 8" in seismic installations).

##### 5.1.2 Grid Attachment

All grid components that interface with the trim must be attached to the trim with FXTBC clips (included with the trim).

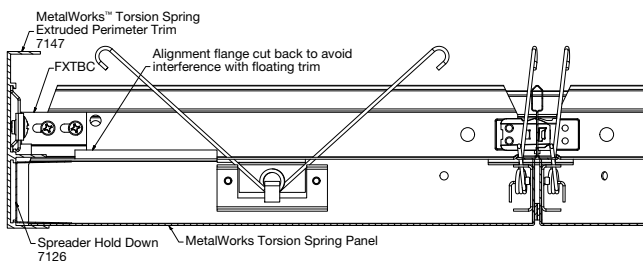

### 6. TRANSITIONS

#### 6.1 Using Axiom® Transitions

Installations that transition a METALWORKS™ Torsion Spring Shapes installation to another ceiling (i.e. mineral fiber ceiling, gypsum) must account for the 1-1/2" panel offset from the grid face. The Adjustable Trim Clip (7239) can be used with Axiom Transitions except for those with an elevation change of 2" or greater. Refer to Adjustable trim clip video and/or Axiom Transitions Installation Guide for details.

##### 6.1.1 Suspension Rules

Refer to the Axiom Transitions instructions for details on suspension rules.

##### 6.1.2 Grid Attachment

Refer to the Axiom Transitions instructions for details on grid attachment.

### 7. PANELS

#### 7.1 Edge Details/Interface

##### 2D Panels:

All 2D panels have a 1-1/2" offset between the face of grid and face of panel.

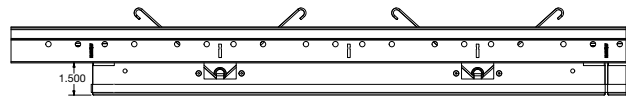

##### 3D Panels:

3D panels are triangles that have a 4" drop on one or two corners of the panel and a 1-1/2" drop on the remaining corners.

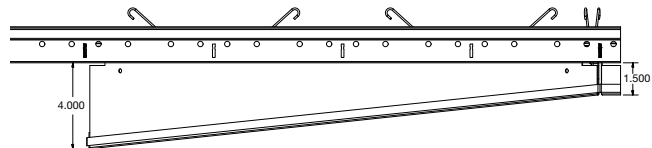

#### 7.2 Panel Reveal

Panels have a 1/8" reveal that is maintained with foam tape (gasket) around the panel edges. This reveal is designed to accentuate panel shapes while helping to account for tolerances within an installation.

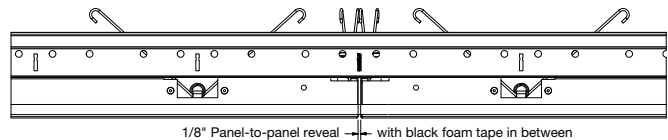

### 7.3 Directionality and Color/Finish Considerations

**7.3.1 Panel finishes:** Panels are available in four standard colors: Whitelume (WHA), Silverlume (SIA), Gun Metal (MYA), and Black (BL). Silverlume and Gun Metal have slight directionality that might be visible in certain low-raking light conditions. Upon receipt, panels will have directionality marked by arrows on clear protective film. Do not remove film until the panels are fully installed in the ceiling system.

#### 7.3.2 Panel Shapes:

All panels must be installed in a specific orientation in order to match the architectural ceiling plans (by others). The specified layout design will dictate the direction of the panels.

### 7.4 Panel Installation

**Step 1** While holding the panel vertical, compress the springs on the top edge of the panel and insert into the corresponding slots. Do not fully engage the springs at this point.

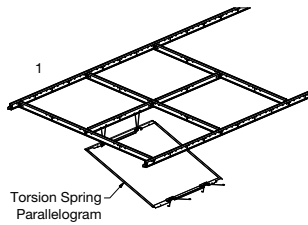

**Step 2** Swing the bottom edge of the panel up to the grid and compress and insert the remaining springs into the corresponding slots.

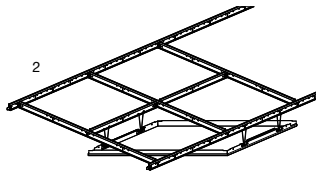

**Step 3** When all springs are inserted into slots and the panel is hanging level below the grid, press up on the panel near each spring location.

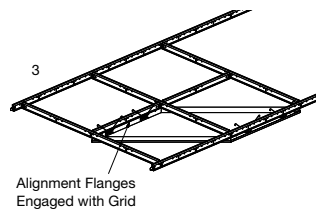

The springs will spread apart and pull the panel tight against the grid and into proper alignment. Be sure that the alignment flanges are inside of the grid flanges for proper panel alignment and levelness.

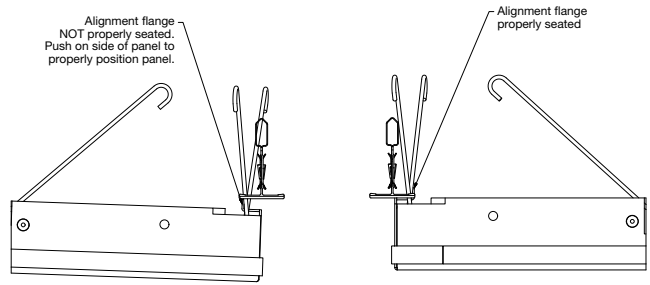
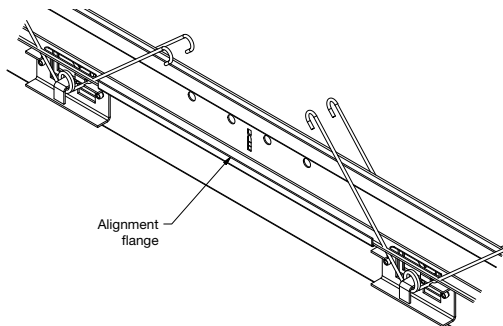

**Step 4** Upon receipt, panels will have directionality marked by arrows on clear protective film. **Do not** remove film until the panels are fully installed in the ceiling system in an attempt to keep dirt and finger prints off of the face of the panel. Once the film is removed, there may be small film remnants left on the face of the panel. These can be simply removed by taking the previously removed ball of film and touching it to the remnant.

### 7.5 Perimeter Panels

Perimeter panels are installed by concealing the edge on the flange of the perimeter trim. If panels are cut, the cut edge must be held down against the trim for a consistent visual and to help keep perimeter panels in alignment.

For perimeters using Box Molding (7125), or Torsion Spring Perimeter Trim (7147), Spreader Hold Downs (7126) must be used. Each Spreader Hold Down is 10-5/8" long and it is recommended to use one per linear foot of cut panel edge. These are needed to ensure that the cut panel face is tight against the flange of the molding.

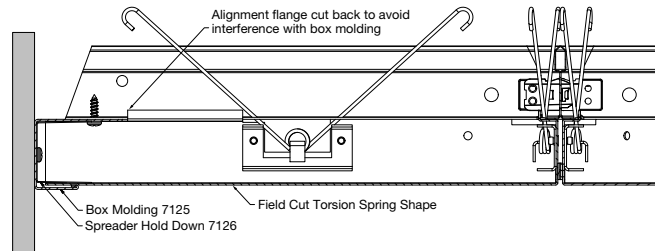

For perimeters using Axiom trim, the Axiom Serpentina Hold Down Clip (AXSPTHDC) must be used. Install as needed to ensure that the cut panel face is tight against the flange of the trim.

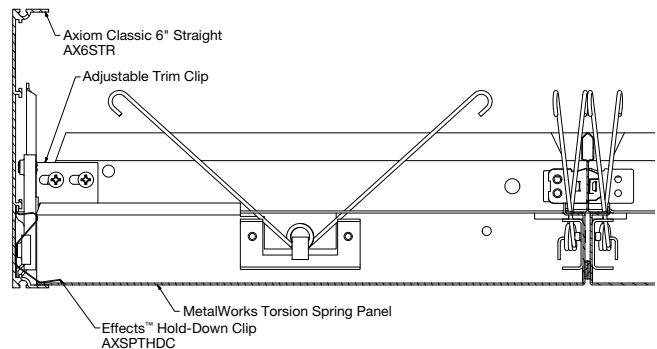

### 7.6 Cut Panels

**7.6.1** Only full-size panels are permitted within the field of the installation. Penetrations can be made in panels following instructions in section 8, but panels cannot be field cut to sizes that are not full module within the field. Instructions for the integration of MEP is addressed in section 8.1.



**7.6.2** Cut panels should never occur within the field of the ceiling. All ceiling mounted services must either replace a full panel, install into a hole that is cut into a panel, or be mounted through the face of a panel.

**7.6.3 Cutting instructions**

Panels can be cut to size at the perimeters using standard tools and methods for aluminum panels.

- For straight cuts, it is recommended to use a metal cutting circular saw with a non-ferrous metal cutting blade (consult blade manufacturer for specific recommendation).
- For curved cuts, it is recommended to use a jigsaw with an aluminum cutting blade or electric metal cutting shears.
- The quality of the cut can impact the flatness of the cut edge, which may require additional Spreader Hold Downs or Effects™ Hold-Down Clips (AXSPTHDC).
- Depending on the size and orientation of the cut, the Alignment Flange of the cut panel may have to be trimmed with tin snips so that the cut end of the panel can fit inside of the Box Molding or trim. See detail below:

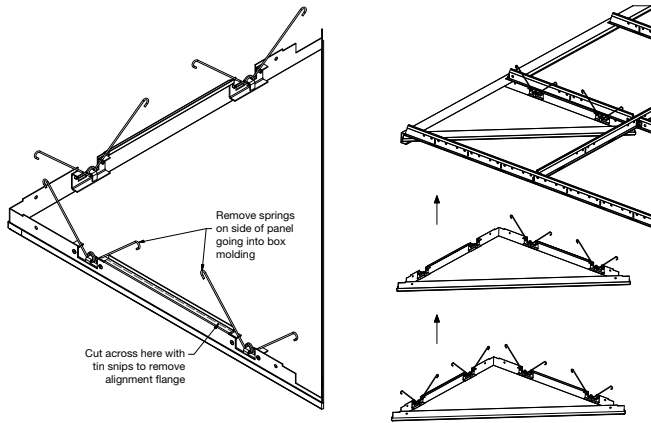

**7.7 Panel Removal**

**7.7.1** All panels are removable without moving them up into the plenum. There are two different panel removal tools. The Hook Panel Removal Tool (BP7129) can be used for non-perforated and perforated panels. The Suction Panel Removal Tool (BP7130) can only be used on non-perforated panels.

**NOTE:** For the Hexagon panel group, see separate instructions in section 7.7.3

**7.7.2** Hook Panel Removal Tool steps (BP7129) for 2D and 3D shapes:

1. The Hook Panel Removal Tool, item BP7129, for perforated or unperforated panels, is inserted into the joint between two panels.

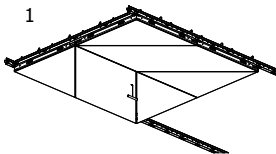

2. Make sure you insert the tool between the gaskets. Best access point is at the corner of the panels.

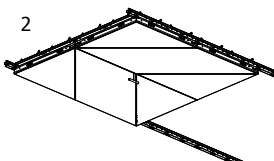

3. Twist the tool 90° to hook the top of the panel.

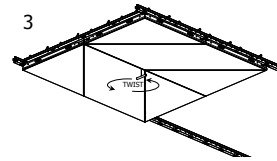

4. Then pull the tool downward, slowly, until the spring catches on the flange of the grid and can be seen.

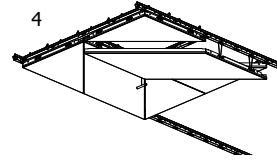

5. Now that the spring has become accessible, push the spring together, slide it down through the slot, and pull down gently to release the panel from the main beam.

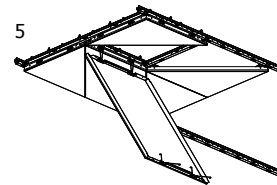

**7.7.3 Hook Panel Removal Tool steps (BP7129) for Hexagon-based shapes:**

Follow steps 1-5 in section 7.7.2 except when inserting the hook panel removal tool, be sure to only insert it along the edges of the hexagon following the main beams, never at the center corner opposing corner points where the magnets are located. Damage can occur if access tool is used at these points of the hexagon.

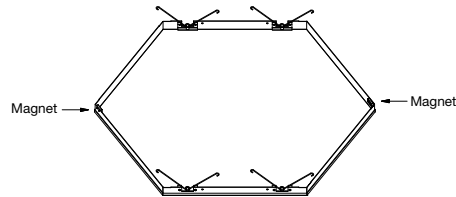

**7.7.4 Suction Panel Removal Tool Steps:**

1. The Suction Panel Removal Tool (item 7130) is for unperforated panels only. Place the device on the corner edge of the panel and gently pull down until the spring is accessible.
2. Push the spring together and pull down gently to release the panel from the main beam.

**7.7.5** Adjacent panels may be removed from the same row of main beams without further use of the tool.

**7.7.6** The panel is designed to provide swing-down accessibility. Using one of the above methods, pull the panel down until all springs catch on the flange of the grid and can be seen. Disengage all springs except the springs on one of the base sides of the panel. This will allow the panel to swing down and be supported by the springs on one base side. Be sure to “guide” the panel into its resting position to avoid introducing unnecessary forces into the panel or system.

For parallelograms (BP8216 P03-P06) it is not recommended to leave the panel in the vertical/swing-down position, as the geometry of the shape may cause the panel to torque the grid flange. For these panels, the swing-down feature is only intended to assist with panel installation and removal.

## 8. SPECIAL CONSIDERATIONS FOR MEP INTEGRATION

**8.1** Per section 2.3, the face of all MEP fixtures will be flush with the ceiling if it drops 1-1/2" below the face of the grid.

### 8.2 MEP Integration for 4" and 6" Technical Zones

#### 8.2.1 Technical Zone Integration

A linear technical zone is the recommended way to integrate linear fixtures into a METALWORKS Torsion Spring Shapes installation. This is achieved by building technical zones with mains that run parallel to the standard mains in the system.

#### 4" Technical Zone:

4" technical zones must be installed parallel to the mains in the system.

**Back view - lighting integration in 4" technical zone parallel to main beams**

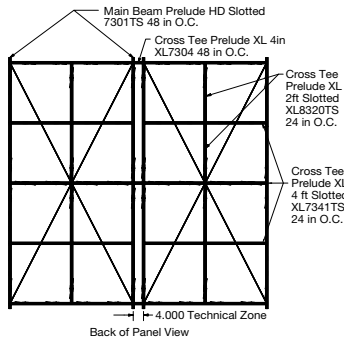

**Face view - lighting integration in 4" technical zone parallel to main beams**

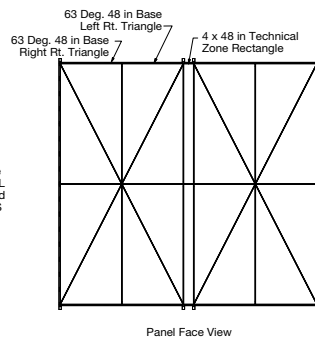

#### 6" Technical Zone:

6" technical zones can be installed parallel or perpendicular to the mains in the system.

**Back view - lighting integration in 6" technical zone parallel to main beams**

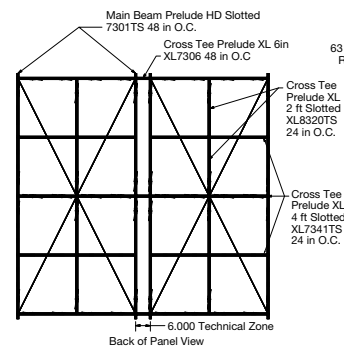

**Face view - lighting integration in 6" technical zone parallel to main beams**

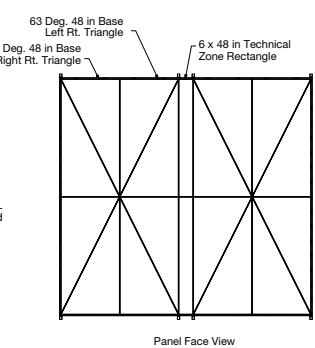

**Back view - lighting integration in 6" technical zone perpendicular to main beams**

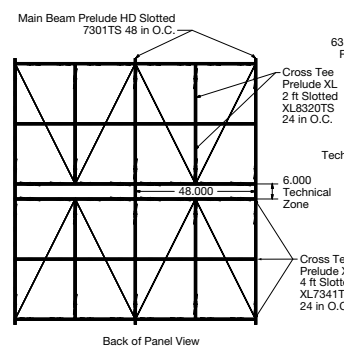

**Face view - lighting integration in 6" technical zone perpendicular to main beams**

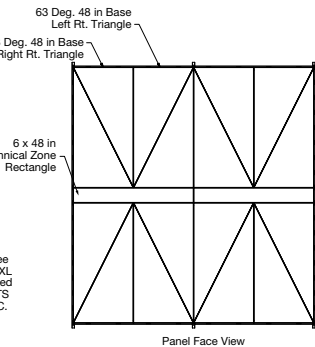

#### Technical Zone with Hexagon Panels:

Due to the panel layout, when integrating Technical zones with Hexagon Panels, the Technical Zones must be parallel with the mains.

**Back view - lighting integration in technical zone parallel to main beams**

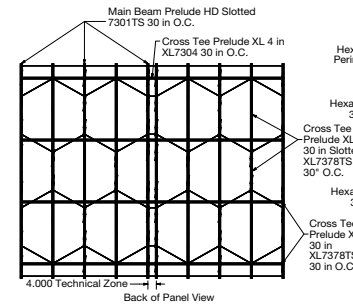

**Face view - lighting integration in technical zone parallel to main beams**

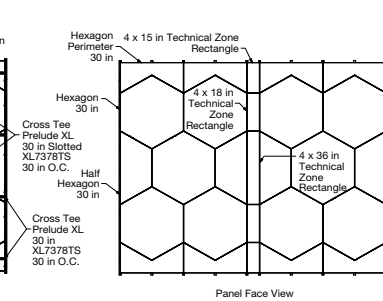
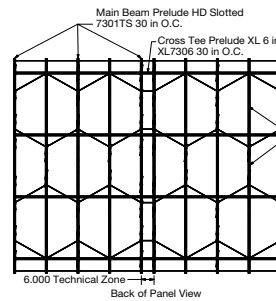
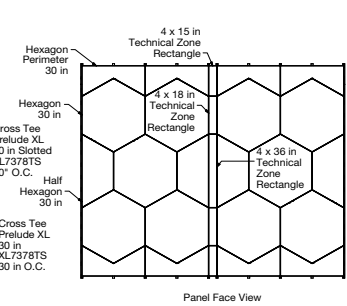

#### 8.2.2 Lights

**8.2.2.1** The following lights have been tested and qualified for integration utilizing the panel with cutout for technical integration:

- Axis™ BEAM2 LED Pendant Light with the 4" panel.
- Axis BEAM4 LED Pendant light fixtures with the 6" panel.
- Backlight FLUSH SHY 2" LED Linear Pendant lights for 4" panel.
- Backlight FLUSH SHY 4" LED Linear Pendant lights for 6" panel.

For actual dimensions, please see CAD details on [armstrongceilings.com](http://armstrongceilings.com).

#### Panel with Cutout for Lighting Integration

The panel with cutout for Lighting integration is a technical sized rectangle panel with a hole cut out of the center. There are 4 standard panel sizes with cut outs in the center to fit the BEAM2 and BEAM4 LED light fixtures as well as light fixtures by Backlight. Please reference CAD details on the website for exact panel dimensions and compatible light fixture dimensions.

Compatible lighting fixtures and drivers should be installed by a qualified electrician. Please refer to the lighting partner manufacturer (Axis™) for instructions. The 2" Axis BEAM2 LED independently suspended pendant fixture works with Armstrong panel 8266 C01 for 2' x 2' grid layouts and panel 8267 C01 for hexagon grid layouts. The Axis BEAM4 LED independently suspended pendant fixture works with Armstrong panel 8266 C02 for 2' x 2' grid layouts and panel 8267 C02 for hexagon grid layouts. Compatible Backlight independently suspended light fixtures are available as well and offer both a flush visual or a Tegrular drop visual by simply dropping the face of the light 1/4" below the 1.5" drop of the panel.

Compatible lighting fixtures and drivers should be installed by a qualified electrician. Please refer to the lighting partner manufacturer (Axis™) for instructions. The 2" Axis™ BEAM2 LED works with the 4" panel for technical zones. The 4" Axis™ BEAM4 LED works with the 6" panel for technical zones. The light and driver must be independently supported per the manufacturer's instructions.

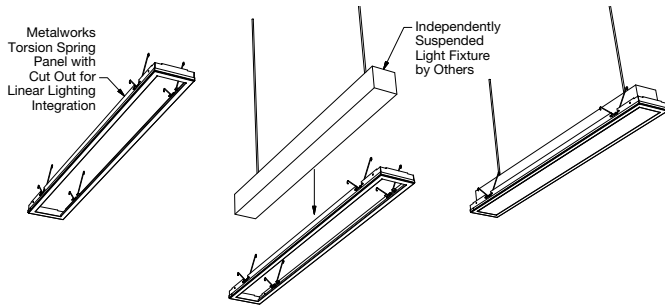

**8.2.2.2** Pendant lights are also able to be used at the intersections of panels. The electrical cord must be wrapped in foam at any locations that could come into contact with metal panel for safety precautions. The light also must be independently supported.

**8.2.2.3 Downlight Installation in a Hexagon System**  
**Hexagon grid layout modifications to allow for centered installations of lighting / diffusers / sprinklers / etc.**

When planning fixture outrigger bracing, please note that the Hexagon system utilizes 15" and 30" grid spacing. Standard fixture bracing may need to be extended if the 30" spacing is used.

STAC clips are needed at all open grid locations not paired with an adjacent cross tee.

**8.2.3 Diffusers**

**Diffuser Partners Integration:** Compatible fixtures should be installed by a qualified mechanic. Please refer to the diffuser partner manufacturer for instructions. Price® diffusers, with a 1-1/2" drop from the grid face, have been tested to integrate with METALWORKS Torsion Spring Shapes system. Diffusers must be independently supported per the manufacturer's instructions.

It is recommended to field-apply 2-3 extra layers of foam tape (gasket) to the Torsion Spring panel edge that borders a diffuser to maintain a proper reveal and reduce gaps or possible light leak from the plenum.

**8.3 Integrating Continuous Linear Fixture with BP8218 Trim**

METALWORKS Torsion Spring Shapes Trim (8218) will cover the side of the panels and allow for full-size panels to be installed up to a continuous linear fixture of any width between 3 and 9" utilizing the TechZone Yoke (TZYK) for connecting the Main Beams.

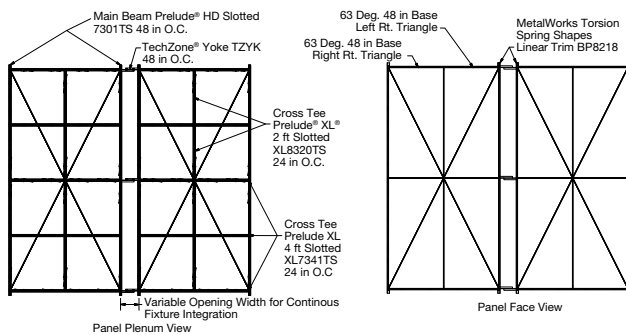

The trim is designed for use with continuous linear fixture openings that run parallel to the main beam direction, and are framed with mains. An optional layer of foam tape (gasket) can be applied to the trim, if desired. The trim is screw-attached to grid that frames the linear opening and is only compatible with full-size panels.

The trim can be used with different width linear openings, and the grid spacing can be held in place with the Adjustable Grid Spacer Clip (GSC9) or TechZone® Yoke (TZYK).

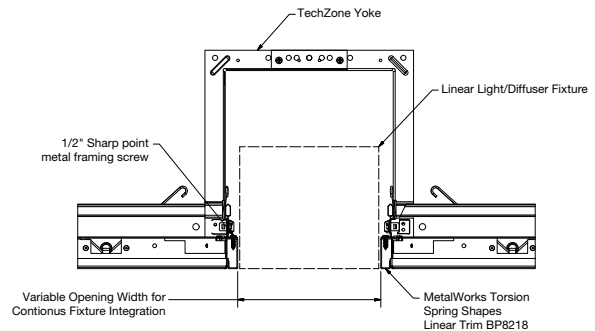
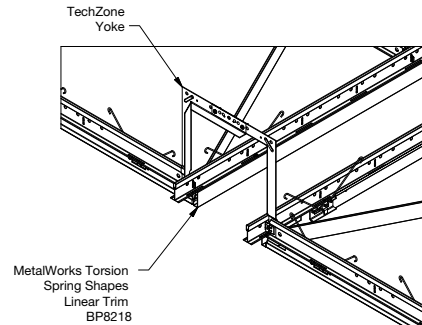

**Installation Steps:**

1. Align the face of the trim with the edge of the grid flange facing the linear opening.

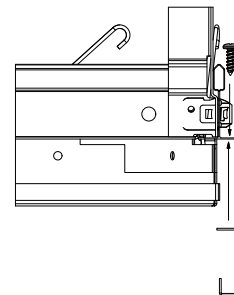

2. Use 1/2" sharp point metal framing screws (provided by contractor) to fasten the trim to the grid no more than 24" O.C. and within 8" of each end of the trim. If the fixture will interface with the grid flange then the trim must be screwed from the top down.

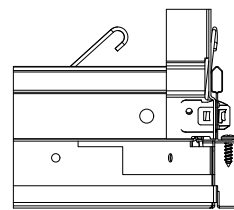

If the trim must be cut, it is recommended to use a metal cutting circular saw with a blade for non-ferrous metal.

### 8.3.1 Non-Linear Lighting/MEP Integration Hexagon grid layout modifications that allow for centered installations of lighting / diffusers / sprinklers / etc.

When planning fixture outrigger bracing, please note that the Hexagon system utilizes 15" and 30" grid spacing. Standard bracing may need to be extended if the 30" spacing is used.

STAC clips are needed at all open grid locations not paired with an adjacent cross tee.

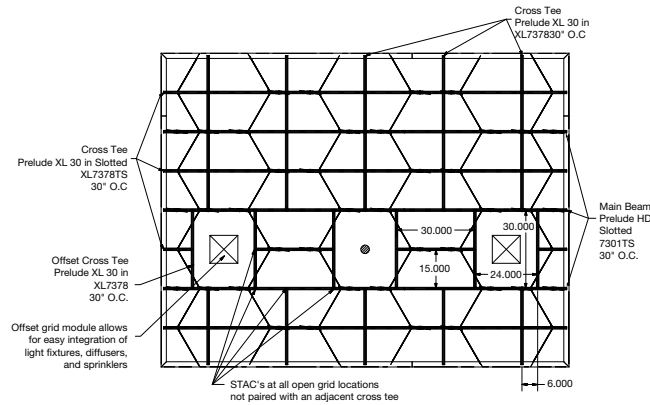

For 2' x 2' grid layouts and panels consider placing lights, diffusers, sprinklers, etc. into square panels throughout the pattern. Example: Patterns TS-0003.

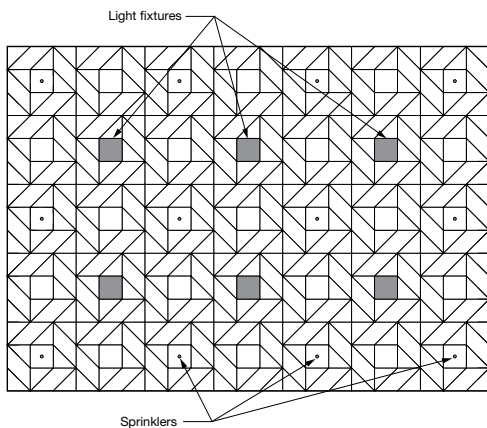

### 8.4 Sloped Installation

For more information on sloped installations, please see our brochure: "Sloped Ceilings: Technical and Installation Guide". The main beams must be installed in the direction of the slope, not perpendicular to it. The maximum ceiling slope cannot be more than 30°. Use the METALWORKS™ Torsion Spring wind retention clips to lock the spring into place to limit the spring and panel from sliding down the slope. Please note that this will limit the ease of accessibility, but the panel is still accessible after the clip is removed.

### 8.5 Single Tee Insertion

Design layouts that include single cross tee insertions of XL end details (i.e. technical zone layouts) will require use of the STAC. Refer to STAC document for full instructions on the use of this clip.

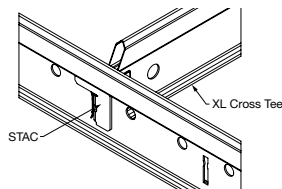

### 8.6 Exterior Application

METALWORKS Torsion Spring Shapes are designed for interior installations only and cannot be installed in any exterior applications.

## 9. SEISMIC

### 9.1 General

For more details on Seismic installations please see our brochure: "Seismic Design: What You Need to Know".

### 9.2 Suspension System

All seismic installations of METALWORKS Torsion Spring Shapes must be installed per seismic design categories D, E, F. This is regardless of the total system weight. Heavy-Duty grid is required per ASTM E580.

#### 9.2.1 Seismic Rx Cat D, E and F

Ceiling installation should conform to basic minimums established in ASTM C636, in addition to:

- Minimum 7/8" wall molding.
- Suspension system must be attached on two adjacent walls.
- Opposite walls require BERC2 and allow 3/4" movement at the wall.
- BERC2 maintains main beam and cross tee spacing; no other components required.
- Heavy-Duty systems as identified in ICC-ESR-1308.
- Safety wires required on light fixtures.
- Perimeter support wires within 8" of the perimeter angle.
- Ceiling areas over 1,000 SF must have horizontal restraint wire or rigid bracing.
- Ceiling areas over 2,500 SF must have seismic separation joints or full-height partitions.
- Ceilings without rigid bracing must have 2" oversized trim rings for sprinklers and other penetrations.
- Changes in ceiling plane must have positive bracing.
- Cable trays and electrical conduits must be independently supported and braced.
- Suspended ceilings will be subject to special inspection.
- Connection to wall – See BPCS-4141 *Seismic Design: What You Need to Know – Code Requirements Seismic Rx® Tested Solutions – SEISMIC RX® APPROACHES TO CATEGORY C and D, E, F INSTALLATIONS.*
- Special bracing required – See BPCS-4141 *Seismic Design: What You Need to Know – Code Requirements Seismic Rx Tested Solutions – Bracing and Restraint for Seismic Installations.*
- Seismic separation joints – See BPCS-4141 *Seismic Design: What You Need to Know – Code Requirements Seismic Rx Tested Solutions – Seismic Separation Joints.*

### 9.3 Perimeter Attachment

In order to use the BERC2 as part of the Seismic Rx® method, 7800 Angle Molding must be installed above the 7125 Box Molding. This 7800 Angle Molding will allow the BERC2 to be installed as detailed in the “*Seismic Design: What You Need to Know*” document.

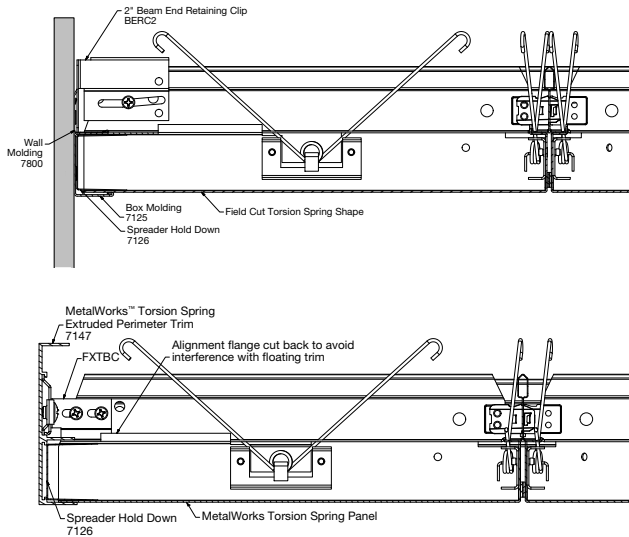

### 9.4 Panel Installation

#### 9.4.1 Field Panels

Panels within the field of the installation are installed as in Seismic Design Category A, B builds. There are no additional requirements.

#### 9.4.2 Perimeter Panels

Panels at the perimeter of the installation should be treated as in section 7.5 for Seismic Design Category A, B builds.

### MORE INFORMATION

For more information, or for an Armstrong Ceilings representative, call 1 877 276 7876.

For complete technical information, detail drawings, CAD design assistance, installation information, and many other technical services, call TechLine customer support at 1 877 276 7876 or FAX 1 800 572 TECH.

For the latest product selection and specification data, visit [armstrongceilings.com/shapes](http://armstrongceilings.com/shapes).

Inspiring Great Spaces® is a registered trademark of AFI Licensing LLC. LEED® is a registered trademark of the U.S. Green Building Council. Price® is a registered trademark of Price Industries Limited. Axis is owned by Axis Lighting. Fantastik® is a registered trademark of S. C. JOHNSON & SON, INC. All other trademarks used herein are the property of AWI Licensing LLC and/or its affiliates.

© 2019 AWI Licensing LLC • Printed in the United States of America

BPLA-299097-419

