

# CastWorks™ Metaphors® Coffers & Infill Panels

## Assembly and Installation Instructions



### 1. GENERAL

CastWorks™ Metaphors® Coffers are 24" × 24" glass fiber reinforced gypsum panels available in five designs (Convex, Crown, Cove, Bead, Linear) and four colors (White, Silver Grey, Gun Metal Grey, Black). A wide selection of nominal 18" × 18" infill panels can be installed in CastWorks Metaphors Coffers. Tegular infill panel options include: MetalWorks™ Tegular, WoodWorks® Tegular, and Ultima® Tegular. Lay-in infill panel options include Infusions® Lay-in.

#### 1.1 CastWorks Metaphors Coffers Items

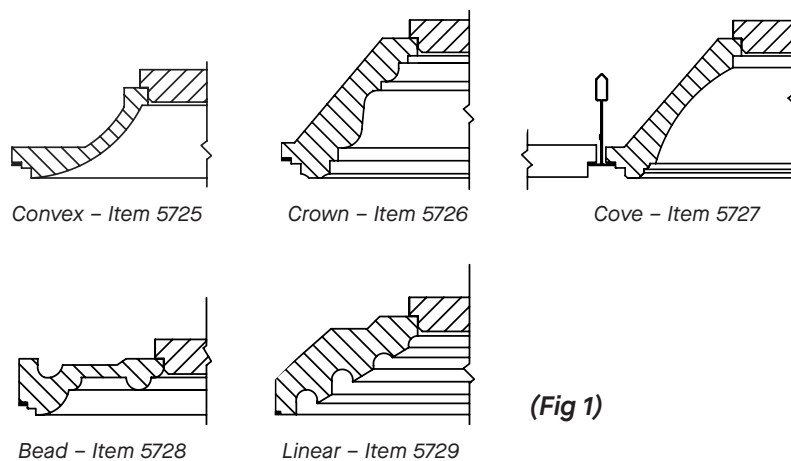

#### 1.2 Infill Panel Material and Surface Finish

MetalWorks Tegular – Electrogalvanized steel; factory-applied powder-coated finish (post-coated)

WoodWorks Tegular – Fire retardant particle board with face-cut veneers; Clear or tinted semi-gloss coating

Ultima Tegular – Wet-formed mineral fiber; DuraBrite® with factory-applied latex paint

Infusions Lay-in – Polycarbonate; smooth

#### 1.3 Storage and Handling

The ceiling components must be stored in a dry interior location and must remain in cartons prior to installation to avoid damage. The cartons must be stored in a vertical position (per red arrows on packaging). The protectors between panels should not be removed until installation. Proper care should be taken when handling to avoid damage and soiling. Do not store in unconditioned spaces with humidity greater than 55% or lower than 25% RH and temperatures lower than 50°F or greater than 86°F. Panels must not be exposed to extreme temperatures, for example, close to a heating source or near a window where there is direct sunlight.

#### 1.4 Site Conditions for WoodWorks

WoodWorks Tegular infill panels should be permitted to reach room temperature and have a stabilized moisture content for minimum of 72 hours before installation. (Remove plastic wrap to allow panels to climatize). They should not, however, be installed in spaces where the temperature or humidity conditions vary greatly from the temperatures and conditions that will be normal in the occupied space. (**NOTE:** Conditions above required for Infusions, MetalWorks, or Ultima installations.)

### 1.5 General HVAC Design & Operation

Proper design for both supply air and return air, maintenance of the HVAC filters and building interior space are essential to minimize soiling. Before starting the HVAC system, make sure supply air is properly filtered and the building interior is free of construction dust.

### 1.6 Temperature & Humidity for WoodWorks® Installation

WoodWorks Tegular infill panels are interior finish products designed for installation in temperature conditions between 50°F and 86°F, in spaces where the building is enclosed and HVAC systems are functioning and will be in continuous operation. Relative humidity should not fall below 25% or exceed 55%. There must be proper ventilation of the plenum in high moisture areas. All plastering, concrete, terrazzo, or any other wet work should be completely dry. (**NOTE:** Conditions above required for Infusions®, MetalWorks™, or Ultima® installations.)

All windows and doors should be in place. The heating, ventilating and air-conditioning system should be installed and operable where necessary to maintain proper temperature and humidity conditions before, during and after installation of the WoodWorks panels.

## 2. SUSPENSION SYSTEMS

Suspension systems, whether 9/16" or 15/16", must be installed to meet the minimum requirements established in the ASTM C636 standard and any other requirements established by local code.

The grid system for 24" × 24" coffers must consist of main beams spaced 48" O.C. The 48" cross tees must intersect the main beams at 90° every 24". The 24" cross tees must be installed at the midpoints of the 48" tees.

The requirements listed here represent the manufacturer's minimum acceptable installation recommendations, and may be subject to additional requirements established by the local authority having jurisdiction.

## 3. INSTALLATION

CastWorks™ Metaphors® Coffers are for full-size panel installation and CANNOT be cut at the border. Clear plenum height must be at least 9 inches to accommodate 24" × 24" CastWorks Metaphors Coffers. Bead profile requires only 5 inches.

### 3.1 Coffer Installation

Install Coffers in 9/16" Suprafine® or 15/16" Prelude® grid.

### 3.2 Infill Panel Installation

Install MetalWorks Tegular, WoodWorks Tegular, and Ultima Tegular panels by carefully inserting them into the Coffers (**Fig 2**).

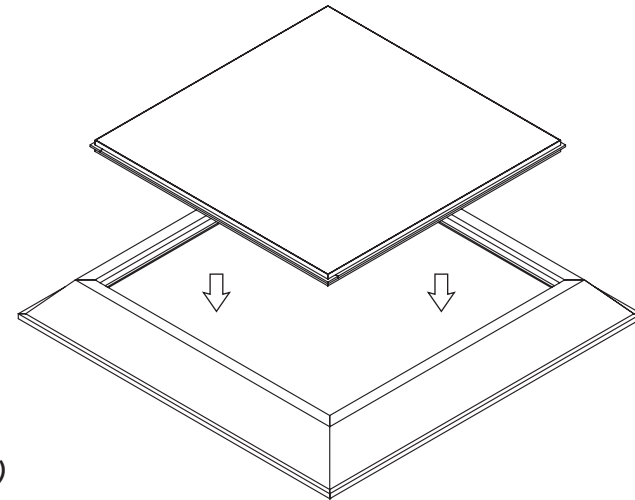

(Fig 2)

To meet seismic requirements, each Infusions Lay-in infill panel carton will include rolls of double-stick tape (Item 8127A84). To install:

1. Cut the clear plastic wrap off of the roll of tape.
2. Inspect the tape for any damage.
3. Wipe down the back of the coffer where the tape is to be placed to remove any dirt or dust.
4. Unroll the tape and cut to a length of 18.50".
5. Carefully peel off one side of the tape's contact paper and place a piece on the back of the coffer starting with the end of the tape at the outside edge of the flat platform.
6. Apply pressure to all areas of the tape to make sure it is securely attached to the back of the coffer. Be careful not to apply too much pressure or you could crack the coffer.
7. Repeat steps 5 and 6 for each coffer side.
8. Once each coffer side has tape applied, carefully peel the contact paper off of the exposed side of tape. Make sure the tape does not come up with the paper.
9. Repeat step 8 for each side.

10. Clean the face of the infill panel that will contact the tape. Line up the corners of the infill panel with the outside of the back of the coffer panel.
11. Put the infill panel in place making sure the edges of the panel are lined up with the outside edges of the flat platform.
12. Apply pressure to the back of the infill panel where it comes in contact with the tape. Be careful not to apply too much pressure or you could crack the coffer.
13. Repeat steps 1-12 for each coffer being installed (*Fig 3*).

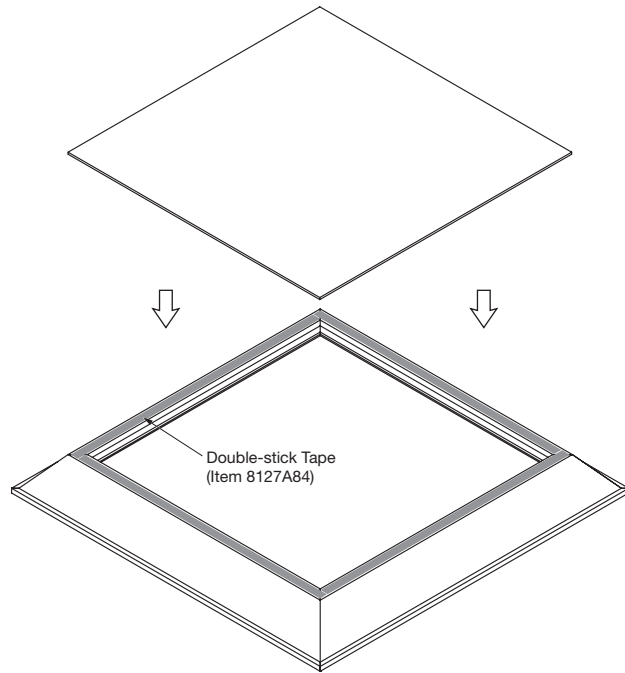

(Fig 3)

### 3.3 Infill Panel Penetrations

Refer to the following when cutting the interior of infill panels for penetrations, cutouts, etc. (sprinklers/lighting). Always wear safety glasses and gloves when cutting panels.

#### 3.3.1 Cutting Infusions Lay-in Infill Panels

Use a Jigsaw to cut a hole or irregular shape in the Infusions panel for the penetration. Use a variable speed Jigsaw with a blade that has 8-12 teeth per inch. Proper support of the part to be cut is important because vibration may induce cracking if the cut is not smooth. Sanding the edge smooth after cutting is recommended.

The Infusions Lay-in panels are easily drilled using ordinary high-speed steel drill bits or hole saw. Regulate pressure and speed until a continuous spiraling chip is observed. Use air as a coolant if required. Recommended drill speed is 350 - 1750 rpm. The Infusions Lay-in panels can be sanded using typical dry techniques. The panels can be buffed using a 2-wheel system. The first wheel uses a buffing compound to remove shallow scratches. The second buffing wheel is used for restoring the gloss.

#### 3.3.2 Cutting MetalWorks Tegular Infill Panels

**CAUTION!** Cut edges of metal parts can be extremely sharp! Handle metal carefully to avoid injury. Reminder – always wear safety glasses and gloves when working with metal.

Three different types of equipment are recommended for cutting metal panels for penetrations – electric shears, duct snips and aviation snips. Each has its own set of advantages and limitations.

#### 3.3.3 Cutting WoodWorks Tegular Infill Panels

Cut the panel using standard woodworking tools and techniques. A Jigsaw is recommended for holes and irregular cuts for penetrations. Panels should be cut face up to minimize chipping of the face veneer. Fine-toothed, down cutting blades are recommended for finish cuts. Holes can be drilled using a variable speed drill and ordinary high-speed steel drill bits or hole saw.

**CAUTION! WOOD DUST.** Sawing, sanding and machining wood products can produce dust. Airborne wood dust can cause respiratory, eye and skin irritation. The International Agency for Research on Cancer (IARC) has classified wood dust as a nasal carcinogen in humans. Precautionary measures: If power tools are used, they should be equipped with a dust collector. If high dust levels are encountered, use an appropriate NIOSH-designed dust mask. Avoid dust contact with eyes and skin. **First Aid Measure in case of irritation:** Flush eyes or skin with water for at least 15 minutes.

### 3.4 Border Panels

For border panels, use the 24" × 24" version of selected infill panel that can be field cut or a suitable acoustical panel like Ultima.

### 3.5 Floating Installations

For floating installations, Profiled Axiom® Trims are available to complement Convex, Crown, and Cove coffer designs. Profiled Axiom can also be used for ceiling transitions, light coves, or other applications. For more information, visit [armstrongceilings.com/axiom](http://armstrongceilings.com/axiom)

## 4. CLEANING AND HANDLING

CastWorks™ Metaphors® Coffers and Infill Panels can be cleaned with a soft, dry cloth.

For Infusions Lay-in infill panels, avoid wiping the panel surface with abrasive compounds of any type. Panels should be handled with clean gloves/hands to avoid fingerprints. Lightly dust with a duster or soft, clean cloth first. A soft sponge slightly damp with lukewarm water and neutral detergent may then be used, taking into account the important note below about avoiding panel edges. Never use razor blades, scrapers, squeegees, brushes, etc. **CAUTION:** Do not allow panel edges to get wet when cleaning the panel surface. This would damage the panel and void the product warranty.

## 5. SEISMIC RESTRAINT

CastWorks Metaphors Coffers and Infill Panels have been engineered for application in seismic areas. This system has been successfully tested in applications simulating seismic design categories D, E, & F.

---

### MORE INFORMATION

For more information, or for an Armstrong Ceilings representative, call 877 276-7876.  
For complete technical information, detail drawings, CAD design assistance, installation information, and many other technical services, call TechLine customer support at 877 276-7876 or FAX 800 572-TECH.

All trademarks used herein are the property of AWI Licensing LLC and/or its affiliates.  
© 2023 AWI Licensing Company Printed in the United States of America

BPLA-297772-1223



**Armstrong**®  
World Industries