

# SERPENTINA® Semi-concealed Tee System (24" x 48" and 24" x 72") Floating Clouds and Perimeter Wall Attachment

## Installation Instructions

The Serpentina Semi-concealed 3-Dimensional Ceiling System consists of a group of standard length curved and straight main beams, straight cross tees, curved and straight perimeter trims, and 24" x 48" and 24" x 72" flexible infill panels. Please read these instructions thoroughly before proceeding. In addition to these instructions, you will have a Serpentina shop drawing, which will illustrate the layout of the components on your project. For additional installation help, call 1-800-840-8521.

**Please note: Serpentina semi-concealed is available in a non-corrosive version for use in pool areas. Adequate ventilation is required in all pool applications. Please check shop drawings to make sure you have received the proper version for your use. Under no circumstances should standard Serpentina be installed in a pool area or other corrosive environment. No Serpentina panels should be used in an exterior installation. See drawing on page 8 for a list of components to be used on Serpentina installations in pool applications.**

**Main Beams** are formed from extruded aluminum and offered in nominal 4', 6', 8', and 10' lengths, straight or curved to form "hills" and "valleys." Main Beams are routed 12" on center and have clips on the ends that snap lock together. Main beams that will intersect with perimeter trim are specially sized and are shipped without splice details. Main beams are curved to form arcs that represent 7.5, 15, 22.5, 30, 37.5, 45, 52.5, 60, 75, or 90 degrees of a circle.

**Cross Tees** are 2' extruded aluminum bars fitted with the same XL® end detail used on the Armstrong exposed tee systems.

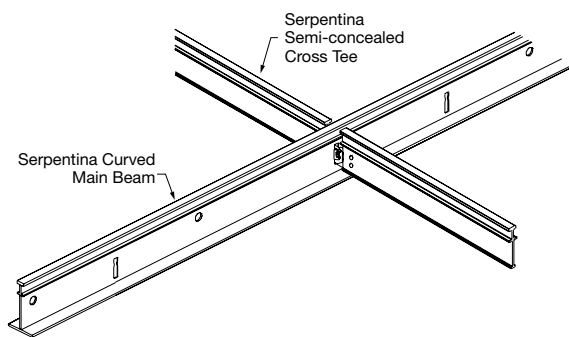

**Serpentina Perimeter Trim** is straight or curved to the same arcs as the main beams. Curved Perimeter Trim runs parallel to the main beams at each side of a floating installation. Straight Perimeter Trim closes off the ends of floating installations. The curved Perimeter Trim will be cut to size. No field cutting is required unless the job conditions alter the original design.

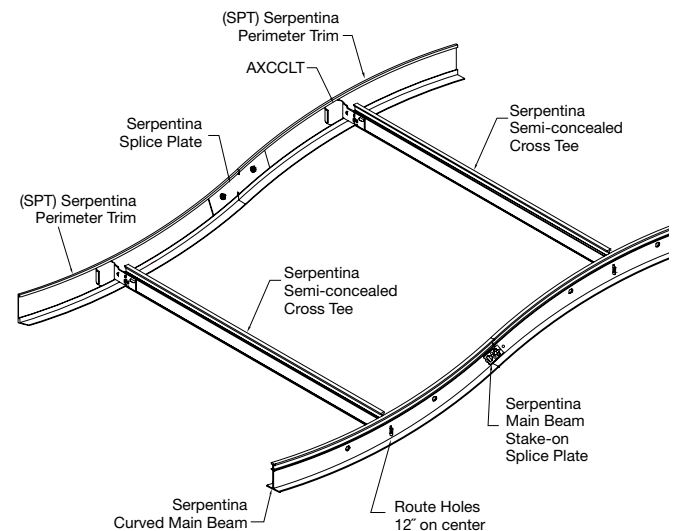

**Serpentina Perimeter Trim Clips (AXCCLT Clips)** are used for the attachment of the suspension system (main beams and cross tees) to the Serpentina Perimeter Trim. Hold the Insertion Tab with pliers and twist to lock into place.

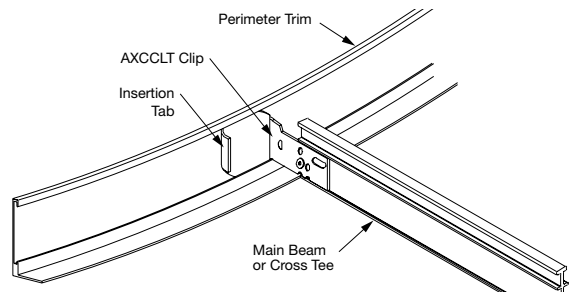

**Splice Plates (AXSPLICE)** are used to align and secure joints between sections of Serpentina® Perimeter Trim. Each joint requires one splice plate. Plates slip fit into abutting pieces of perimeter trim and are secured by tightening setscrews.

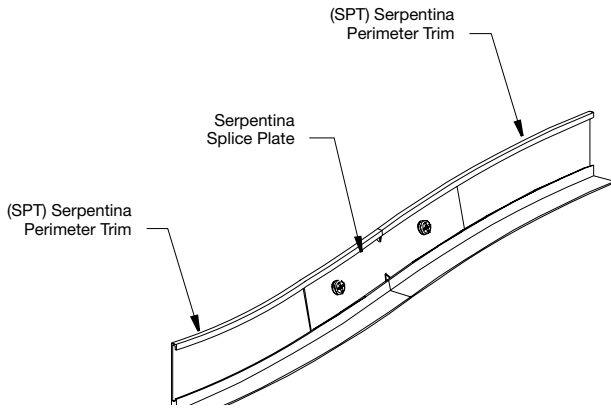

**Corner Posts (SPTOSCP)** are used at the corner intersections to connect a piece of curved perimeter trim to the straight perimeter trim. These corner posts will be shipped already attached to the correct curved perimeter trim pieces.

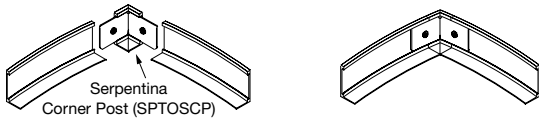

**Serpentina “J” Moldings** are aluminum wall angles that have a short vertical return on the outer edge. These “J” Moldings are for installations where the Serpentina system butts up against a wall or structure and is not “floating”. There are two “J” moldings available, one for a shallow radii (SJMS) and one for a tight radii (SJMT).

1. 90 Degree Hill Intersection
2. 90 Degree Valley Intersection
3. Obtuse Hill Intersection
4. Obtuse Valley Intersection
5. Acute Hill Intersection
6. Acute Valley Intersection
7. Serpentina Wall Molding (SJMS or SJMT)

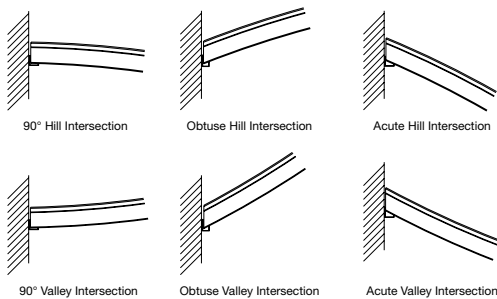

**Infill Panels** are aluminum 24" x 48" or 24" x 72" lay-in panels with short upturns at the ends. These panels are available non-perforated or perforated. There are ten different perforation patterns available (please check pattern availability).

Panels are joined together at the ends with speed clips.

**Serpentina Clear Hold Down Clips (SPTCHDC)** are used to secure the panels into the suspension system. Place clips at the corners of panels installed on a “hill” and at third points along the curved side of a “valley.” Add additional clips as required to maintain contact between the panel face and the suspension system flange.

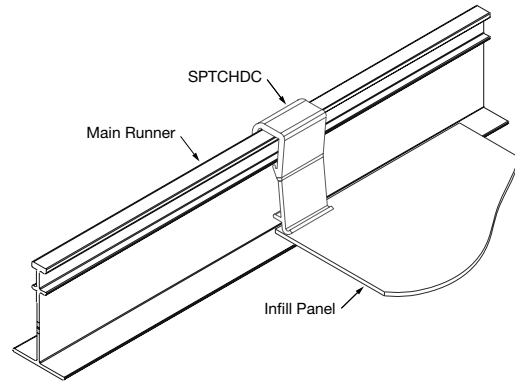

**Serpentina Perimeter Hold Down Clips (AX-SPT-HDC)** are to be used along the perimeter trim (straight and curved). Place one clip for every foot of perimeter, or as needed to maintain contact between the panel edge and the flange of the trim. Insert the top of the clip into the channel first. Press up to compress the clip and insert the bottom leg into the channel.

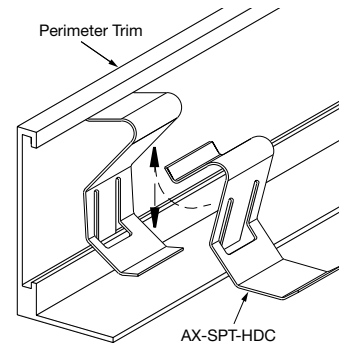

**StrongBack™ Support Channel** is a steel component that carries the weight of the outer 2' of most installations. Use of the StrongBack eliminates the need for hangers outboard of the main beams on installations 6' wide or greater.

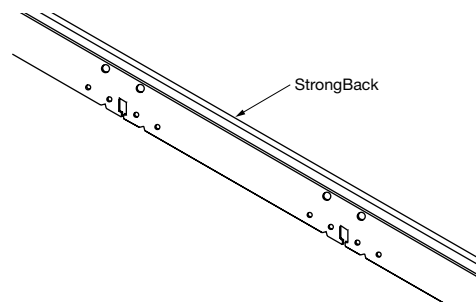

**Speed Clip** is used to join two semi-concealed panels together. Three speed clips are to be installed along each joint where two panels butt end to end.

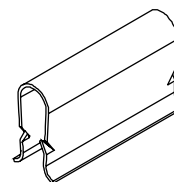

## 1. SYSTEM SUPPORT

1.1 Installations that are 2' wide (one panel width) must be supported from the perimeter trim.

1.1.1 Hangers are to be connected to the trim by means of the Direct Load Hanging Clips (AX2HGC).

1.1.2 The first and last points of support are to be not more than 2' from the ends of the run of trim.

1.1.3 Additional hangers are to be spaced not more than 4' apart along the length of the perimeter trim run.

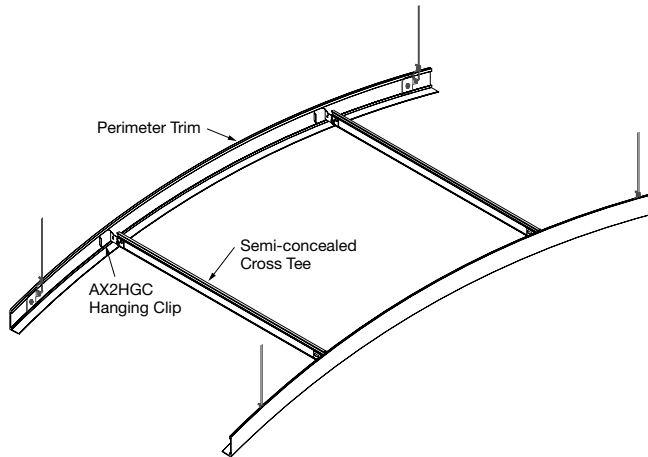

1.2 Installations that are 4' wide (two panel widths) are to be supported as described in section 1.1, but with additional hangers attached to the single row of main beam beginning not more than 2' from the ends and then not more than 4' on center along the length of the run.

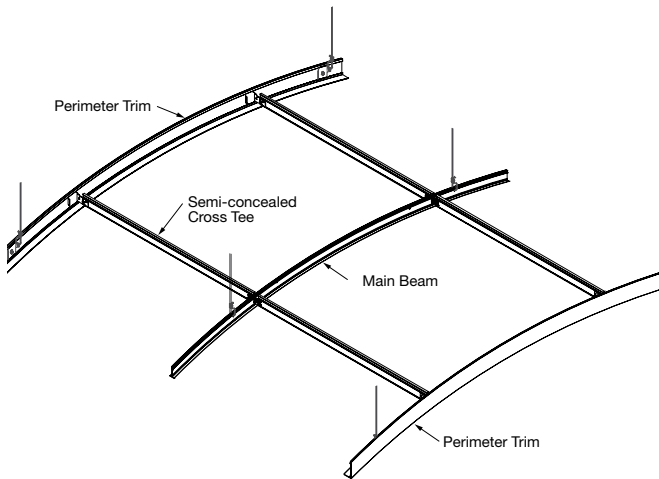

1.3 Installations that are 6' wide or greater are to be supported from the main beams as follows (see final assembly drawings on page 6):

1.3.1 The first and last points of support are to be not more than 2' from the ends of the run of main beam.

1.3.2 Additional hangers are to be spaced not more than 4' apart along the length of the main beam run.

## 2. PERIMETER TRIM PREPARATION

2.1 Mark the locations where the main beams and cross tees will connect to the perimeter trim.

2.1.1 Lay the main beams on top of the sections of perimeter trim that will run parallel and mark the location of the center of the route holes on the flange of the perimeter trim.

2.1.2 Perimeter trim sections that have corner posts attached should be matched up with main beams that have a splice attached to just one end.

2.1.3 Main beams that have splices attached to both ends are to be matched up with perimeter trim sections that are exactly the same length and shape.

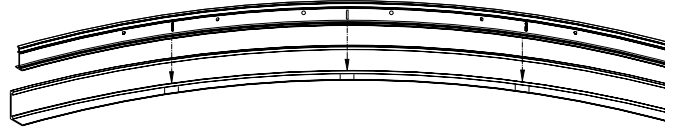

2.2 Mark the straight sections of trim that will be installed perpendicular to the main beams as follows:

2.2.1 Measure and mark 23-1/16" from one end for 15/16" systems (23-7/16" for 9/16" wide systems) and then every 24".

## 3. HANGER WIRE DROP POINTS

3.1 Begin your Serpentina® installation by laying out a reference line on the floor.

3.1.1 Snap a line that represents either the structure to which the hangers will be attached or a line parallel to that structure.

3.2 Lay out a run of main beams at the appropriate location under the reference line.

3.2.1 Protect these main beams from dirt and scratches.

3.3 Determine the location of the hangers along the run of main beams as described in section 1 above.

3.4 Plumb these hanger locations to the reference line. You have now established both the spacing between hangers and the change in length for each location relative to the reference line.

Note that the horizontal spacing between hangers is usually not constant. Map out these locations now and work carefully to maintain the correct locations so that your hangers will be plumb.

## 4. HANGER ATTACHMENT

4.1 Hangers are to be made from minimum 12 gauge soft annealed galvanized steel wire or 1/16" diameter stainless or galvanized steel aircraft cable.

4.2 Hardware used to attach hangers to the building structure shall be appropriate for the site conditions and capable of supporting a minimum of 100 pounds. **If this is a pool application, Monel 400 (Nickel-Copper Alloy) equal in strength to 12 gauge galvanized steel hanger wire is recommended. Please contact the wire manufacturer for technical information on Monel wire.**

4.3 Wire hangers shall be secured at the structure and to the suspension system with a minimum of three wraps completed within three inches.

4.4 Hangers shall be secured to the structure and to the suspension system by means of clamps or compression sleeves appropriate for the cable used and capable of supporting the design load with a safety factor of two.

## 5. INSTALL MAIN BEAMS

5.1 Select main beams carefully, as components are fabricated to be placed in specific locations within the installation.

5.1.1 Main beams are connected end to end by means of factory-applied splices.

5.1.2 Ends of main beams that terminate at perimeter trim DO NOT have splices attached.

5.2 Attach Serpentina® Perimeter Trim Clips (AXCCLT) to the ends of main beams that will terminate at perimeter trim.

5.2.1 Use pliers to twist a clip into the short section of perimeter trim included with the kit of material. It will be located in the bag with the AXCCLT clips.

5.2.2 Clamp the clip to the plain end of the main beam so that the flange of the main beam butts tightly against the flange of the trim.

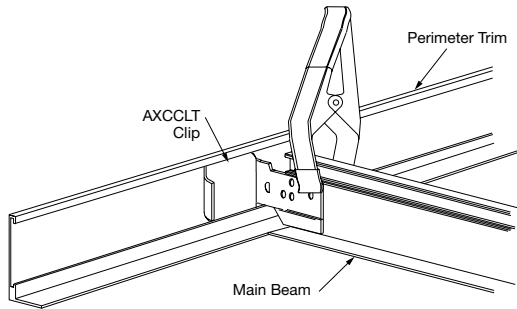

5.2.3 Secure the clip to the main beam with two screws or pop rivets. **NOTE:** Standard framing screws will interfere with the placement of panels into the suspension system. Use 1/4" long screws or pop rivets to reduce this interference.

**NOTE: For pool applications, use only stainless steel screws (provided).**

## 6. INSTALL INTERIOR CROSS TEES

6.1 Install only the cross tees that connect one main beam to another. Perimeter cross tees will be added later.

6.2 Insert the concealed cross tees into the set of route holes that are raised 1/8" higher than normal.

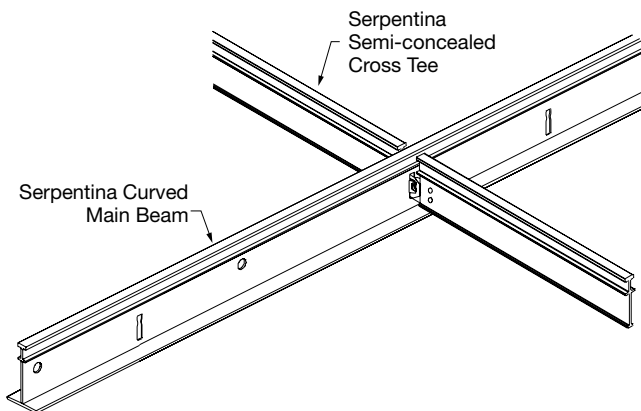

## 7. INSTALL STRAIGHT PERIMETER TRIM

7.1 Install the sections of straight perimeter trim that run perpendicular to the main beam.

7.1.1 Hold the trim in approximate position.

7.1.2 Engage the AXCCLT clips by twisting the ends of the main beams in the counterclockwise direction until the top and bottom edges of the clip engage the grooves in the perimeter trim.

7.1.3 Rotate the clips back to the vertical position. Use a pair of pliers to hold the Insertion Tab. Do not twist the suspension system.

7.1.4 Align the end of the suspension system with the reference marks made on the perimeter trim (section 3). Use a screwdriver or similar tool to tap the clip into position.

**NOTE:** Omit this section for installations that run to a wall. Replace the perimeter trim with the appropriate Serpentina "J" molding (SJMS for shallow radii or SJMT for tight radii). Main beam ends will rest on the Serpentina J molding.

## 8. INSTALL THE STRONGBACK™

8.1 Prepare the StrongBack bars as follows:

8.1.1 Bend open one side of the notch that is located 12" from the end of the bar, and additional notches spaced 24" on center.

8.1.2 Bend all notches in the same direction.

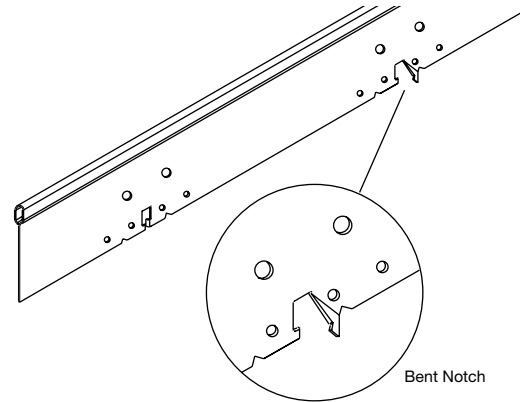

8.1.3 Bend the small tab closest to the end of the bar in the same direction as the notches.

8.1.3.1 These small tabs will ride under the bulb of the perimeter cross tees during final assembly.

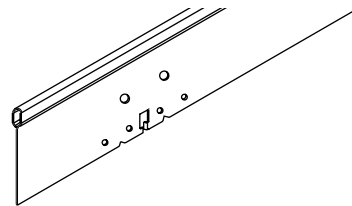

8.2 Place a StrongBack bar over the main beams next to each row of cross tees indicated on the assembly drawing.

8.3 Lock the StrongBacks to the main beams by straightening the bends made in step 8.1.

**8.4** Attach the StrongBack™ bar to the cross tees by inserting screws through the holes provided near each end of each cross tee.

**NOTE: For pool applications, use only stainless steel screws (provided).**

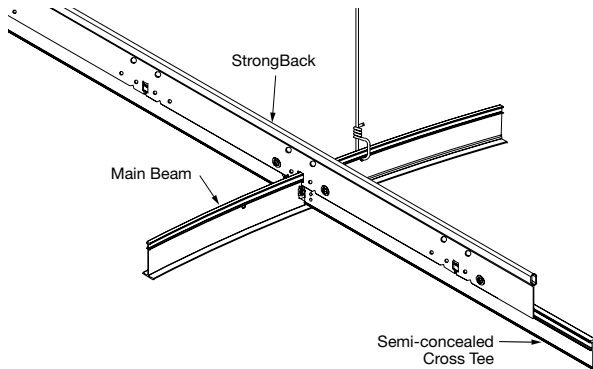

## 9. INSTALL PERIMETER CROSS TEES

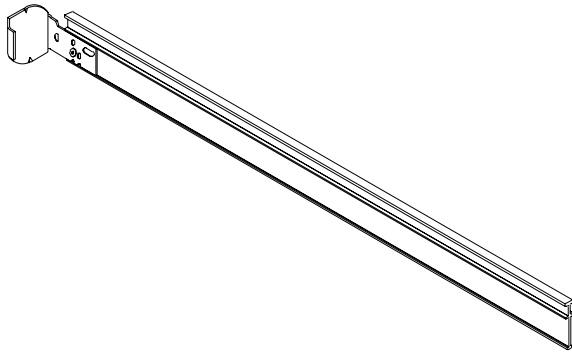

**9.1** Attach the perimeter cross tees to the main beams.

**9.1.2** Rest the bulb of the cross tee on the tab bent in section 8.1.2 and insert a screw through the hole nearest the end of the StrongBack bar.

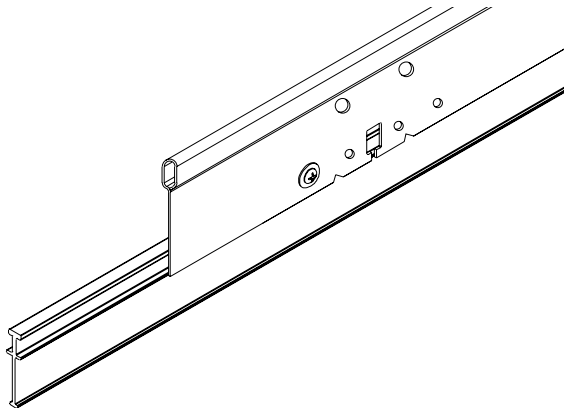

## 10. INSTALL CURVED PERIMETER TRIM

**10.1** Attach the remaining perimeter trim as follows:

**10.1.1** Engage the splice plate that is inserted into the corner post in the grooves on the inside of the straight perimeter trim.

**10.1.2** Twist each cross tee in the counterclockwise direction and engage the AXCLT clip into the grooves in the trim.

**10.1.3** Rotate the clips back to vertical and align to the reference marks you made on the trim (see section 2).

**10.1.3.1** Use pliers to rotate the clips back to vertical by holding the Insertion Tab.

**10.1.4** Attach additional sections of trim as required, inserting a Splice Plate (SPTSPLICE) at each joint.

**10.1.4.1** Use care when tightening the setscrews. Excessive force will deform the face of the perimeter trim.

**10.1.5** Snug up the setscrews on the corner posts to complete the suspension system assembly.

**NOTE:** This perimeter trim may be replaced with main beams for installations that run up against a wall.

## 11. INSTALL PANELS AND HOLD DOWN CLIPS

**11.1** Install panels and hold down clips progressively

**11.2** Install three speed clips along each joint where two panels butt end to end.

**11.2.1** Cut panels using a shear or by scoring with a sharp utility knife.

**11.2.2** Place hold down clips near the corners of panels installed on “hills” and at 1/3 or 1/4 points on “valley” panels.

**11.2.3** Use the clear Serpentina® Hold Down Clips (SPTCHDC) on main beams and the Serpentina® Perimeter Hold Down Clips (AX-SPT-HDC) at the perimeter trim.

## 12. FINAL ASSEMBLY

**12.1** Adjust and clean components as necessary.

**12.2** Use only mild detergent and a damp cloth.

**12.3** Never use abrasives or solvents.

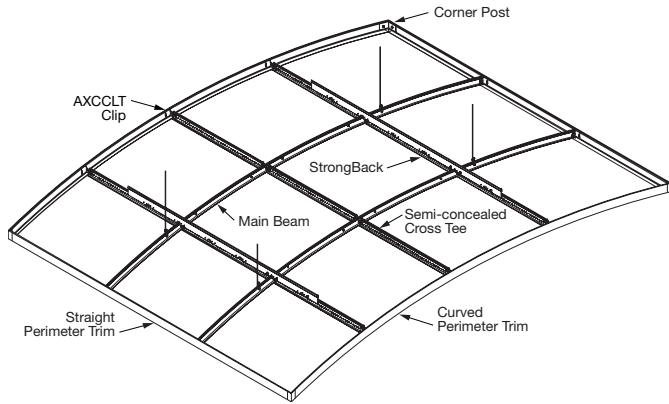

**Assembly Drawing  
(one main beam long)**

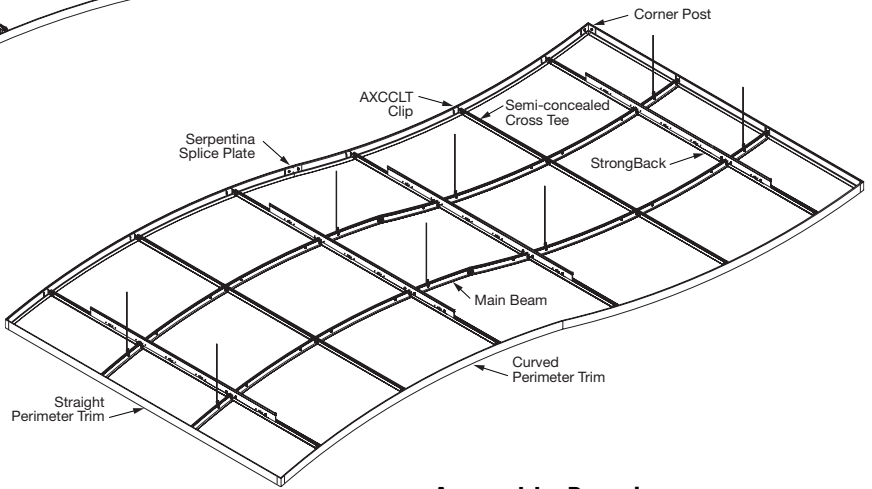

**Assembly Drawing  
(main beams connected end to end)**

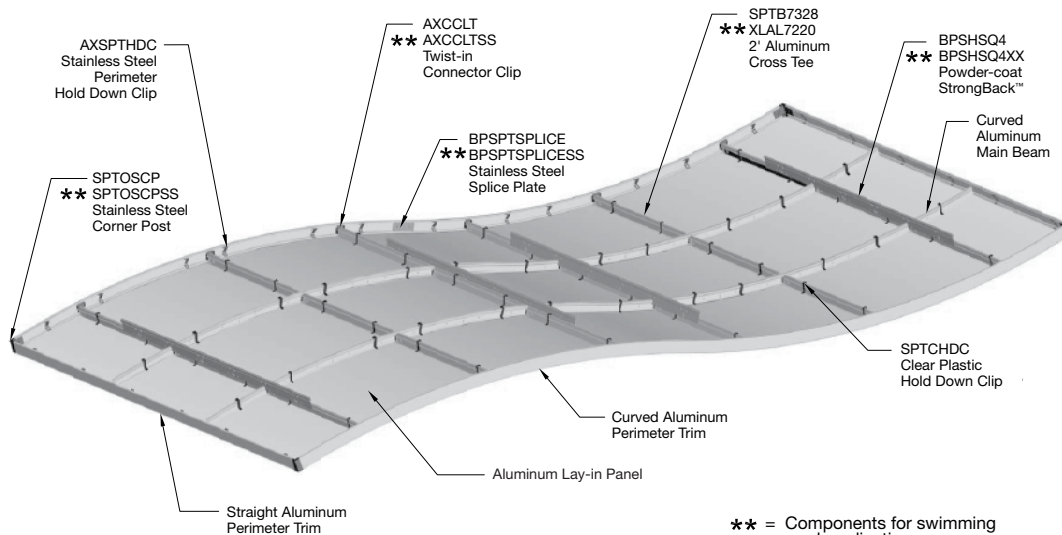

\*\* = Components for swimming pool applications

**Assembly Drawing for Above a Pool  
(144" x 72" module, 630 H/V main beam, 24" x 24" lay-in panel)**



Printed on recyclable paper with vegetable-based inks. Please Recycle. ♻️

**MORE INFORMATION**

For more information, or for an Armstrong representative, call 1 877 ARMSTRONG.

For complete technical information, detail drawings, CAD design assistance, installation information, and many other technical services, call TechLine™ services at 1 877 ARMSTRONG or FAX 1 800 572 TECH.

For the latest product selection and specification data, visit [armstrong.com/serpentina](http://armstrong.com/serpentina) U.S. Patents Pending, including US Publication No. 2004/0182022.



All trademarks used herein are the property of AWI Licensing Company and/or its affiliates © 2014 AWI Licensing Company • Printed in the United States of America

BPLA-297306-414