

# Serpentina® Waves™ Floating Clouds

## Assembly and Installation Instructions

**NOTE:** Please read these instructions thoroughly before proceeding, as the sequence of steps is not the same as for Serpentina exposed or semi-concealed systems. In addition to these instructions, you will have a Serpentina Waves shop drawing, which will illustrate the layout of the components on your project. For additional installation help, call 877 276-7876.

The Serpentina® Waves™ 3-dimensional Ceiling System consists of a group of standard length curved main beams, straight cross tees, curved and straight perimeter trims, and 2' wide flexible infill panels available in lengths from 4' to 12' in 2' increments.

### Main Beams

Main beams are formed from extruded aluminum and offered in nominal 4', 6', 8', and 10' lengths, curved to form “hills” and “valleys.” Main beams are routed to receive concealed spacer tees and have clips on the ends that snap lock together. Main beams are curved to form arcs that represent 7.5°, 15°, 22.5°, 30°, 37.5°, 45°, 52.5°, 60°, 75°, or 90° of a circle.

### Concealed Tees

Concealed tees are 2' extruded aluminum bars fitted with the same XL® end detail used on the Armstrong® exposed tee systems. Tees that will intersect with perimeter trim are specially sized and are shipped with perimeter trim attachment clips factory-installed.

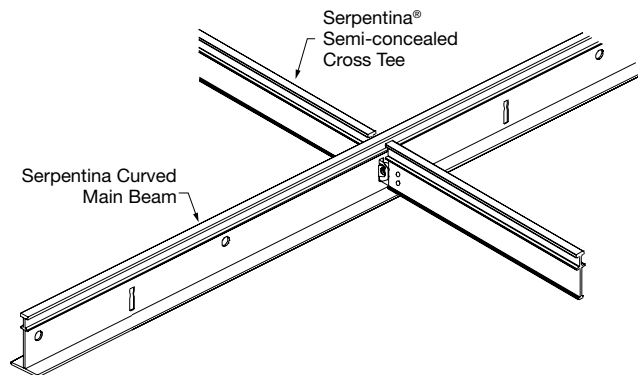

### Serpentina Perimeter Trim

Serpentina Perimeter Trim (SPT) is straight or curved to the same arcs as the main beams. Curved perimeter trim runs parallel to the main beams at each side of a floating installation. Straight perimeter trim closes off the ends of floating installations. All perimeter trim will be cut to size. No field-cutting is required unless the job conditions alter the original design.

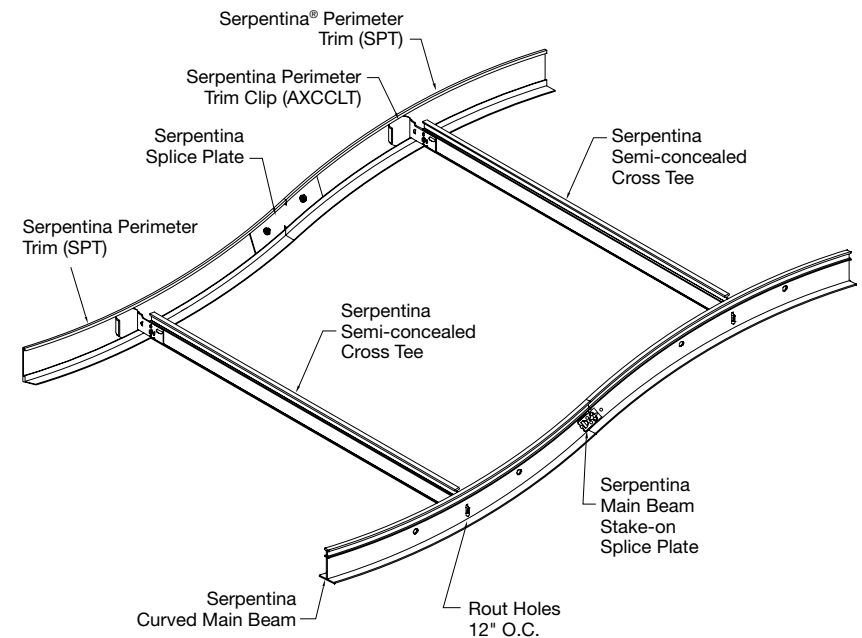

## Serpentina® Perimeter Trim Clips

Serpentina Perimeter Trim Clips (AXCCLT) are used for the attachment of the suspension system (main beams and concealed tees) to the Serpentina perimeter trim. Hold the insertion tab with pliers and twist to lock into place.

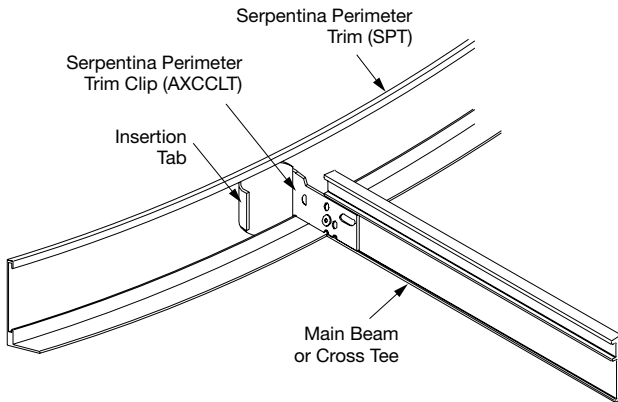

## Splice Plates

Splice Plates (SPTSPLICE) are used to align and secure joints between sections of Serpentina perimeter trim. Each joint requires one splice plate. Plates slip-fit into abutting pieces of perimeter trim and are secured by tightening set screws.

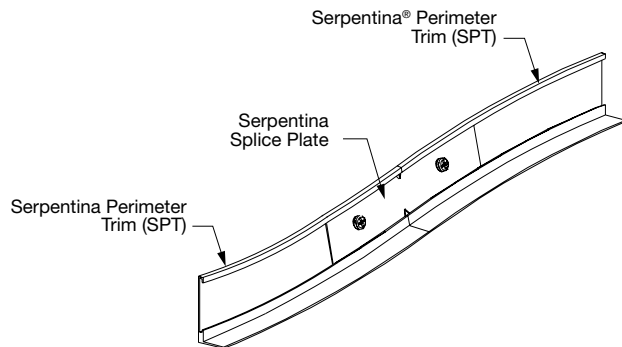

## Corner Posts

Corner Posts (SPTOSCP) are used at the corner intersections to connect a piece of curved perimeter trim to the straight perimeter trim. These corner posts will be shipped already attached to the correct curved perimeter trim pieces.

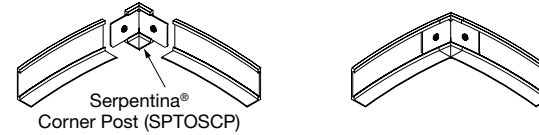

## Infill Panels

Infill panels are aluminum, 2' wide, and supplied in lengths as specified for the project. There are eight different perforation patterns and one non-perforated option available (please check pattern availability). Panels are supplied with PVC hanger strips factory-applied along the full length of long edges on the back side. Panels in the field of the installation will have hangers on both edges. Perimeter panels will have hangers on one edge only.

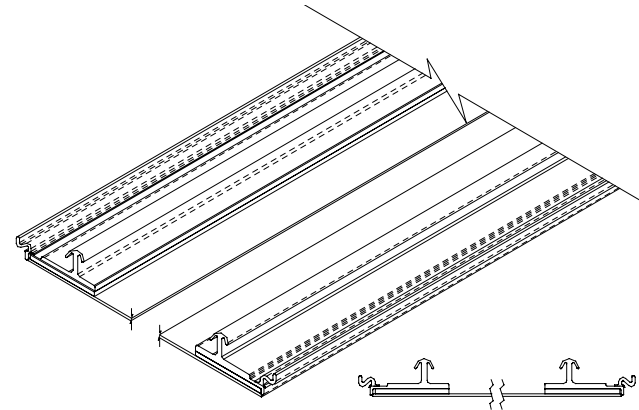

### Serpentina® Waves™ Connector Sleeve

Serpentina Waves Connector Sleeve (SPTCS4-12) is a PVC extrusion that slips over the flange of the main beams. The panel hangers, mounted on the back side of the panels, slide into the grooves on the sleeve. The main beams are completely concealed from view when the panels have been installed.

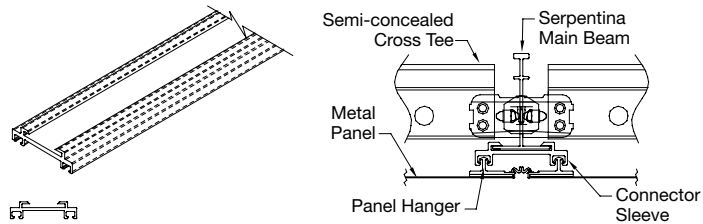

### Serpentina Perimeter Hold-down Clips

Serpentina Perimeter Hold-down Clips (AX-SPT-HDC) are used along the curved perimeter trim. Place clips as needed to maintain contact between the panel edge and the flange of the trim. Insert the top of the clip into the channel first. Press up to compress the clip and insert the bottom leg into the channel.

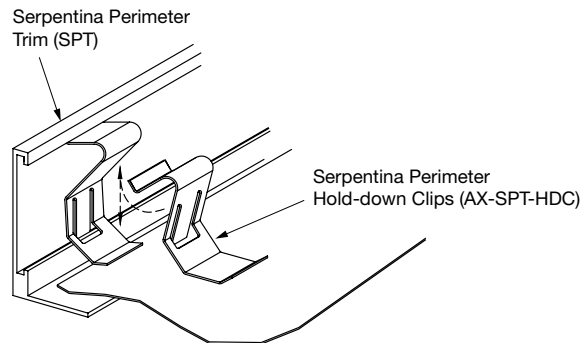

### StrongBack™ Support Channel

StrongBack Support Channel is a steel component that carries the weight of the outer 2' of most installations. Use of the StrongBack system allows the hangers to be placed 2' from the edges on installations 6' wide or greater.

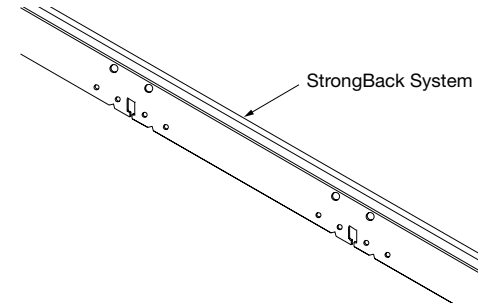

### Speed Clip

Speed Clip is used to join two panels together. Three speed clips are to be installed along each joint where two panels butt end-to-end.

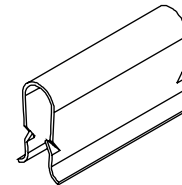

## 1. JOBSITE INSTALLATION GUIDELINES

- 1.1.** A minimum horizontal distance of 24" on the straight perimeter end where the panels will be installed is required.
- 1.2.** A 12" minimum vertical distance to the ceiling is required above the straight perimeter trim where the panels will be installed.
- 1.3.** A minimum distance of 8" is needed on the remaining three sides of the Serpentina® Waves™ cloud. This is to allow installation of our Serpentina Perimeter Hold-down Clips (AX-SPT-HDC). The clearance on the sides can be eliminated by installing the perimeter panels before the adjacent field panels.

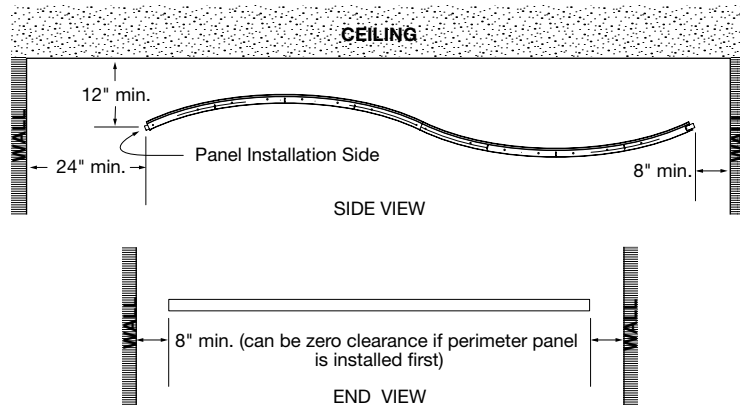

## 2. SYSTEM SUPPORT

**2.1.** Installations that are 4' wide (two panel widths) must be supported from the perimeter trim, with additional hangers attached to the single row of main beams.

- 2.1.1.** Hangers are to be connected to the perimeter trim by means of the Axiom® Vector Hanging Clip (AX2HGC).
- 2.1.2.** The first and last points of support are to be not more than 2' from the ends of the run of perimeter trim.
- 2.1.3.** Additional hangers are to be spaced not more than 4' apart along the length of the perimeter trim run.

**2.1.4.** Hangers are to be attached to the single row of main beams beginning not more than 2' from the ends and then not more than 4' O.C. along the length of the main beam run.

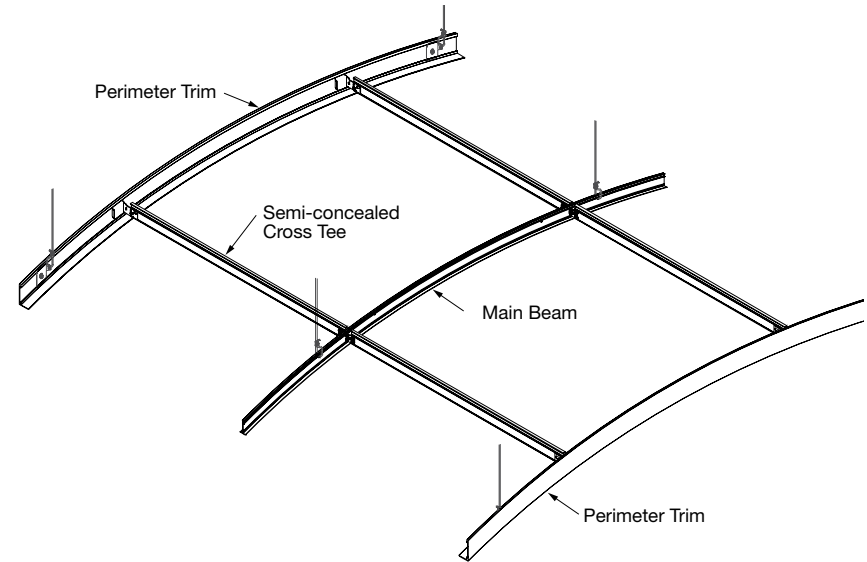

**2.2.** Installations that are 6' wide or greater are to be supported from the main beams as follows (see final assembly drawings on page 8):

- 2.2.1.** Hanger wires are to support the rows of main beams closest to the curved perimeter trim at each side of the installation.
- 2.2.2.** Additional hanger wires should support rows of main beams spaced not more than 4' O.C. Rows of main beams that fall in between those supported by hanger wires will be supported by the StrongBack™.
- 2.2.3.** The first and last points of support are to be not more than 2' from the ends of the run of main beam.
- 2.2.4.** Additional hangers are to be spaced not more than 4' apart, along the length of the main beam run.

### 3. PERIMETER TRIM PREPARATION

**3.1.** Mark the locations where the main beams and cross tees will connect to the perimeter trim.

**3.1.1.** Lay the main beams on top of the sections of perimeter trim that will run parallel, and mark the location of the center of the lower rou holes on the flange of the perimeter trim.

**3.1.2.** Perimeter trim sections that have corner posts attached should be matched up with main beams that have a splice attached to just one end.

**3.1.3.** Main beams that have splices attached to both ends are to be matched up with perimeter trim sections that are exactly the same length and shape.

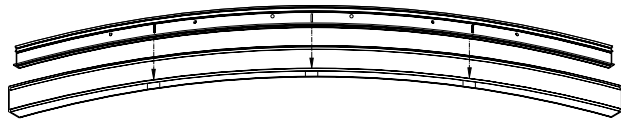

**3.2.** Mark the straight sections of trim that will be installed perpendicularly to the main beams as follows:

**3.2.1.** Measure and mark 23-1/16" from the end.

**3.2.2.** Make additional marks 24" apart along the length of the trim section.

### 4. HANGER WIRE DROP POINTS

**4.1.** Begin your Serpentina® installation by laying out a reference line on the floor.

**4.1.1.** Snap a line that represents either the structure to which the hangers will be attached or a line parallel to that structure.

**4.2.** Lay out a run of main beams at the appropriate location under the reference line.

**4.2.1.** Protect these main beams from dirt and scratches.

**4.3.** Determine the location of the hangers along the run of main beams as described in Section 1.

**4.4.** Plumb these hanger locations to the reference line. You have now established both the spacing between hangers and the change in length for each location relative to the reference line.

**NOTE:** The horizontal spacing between hangers is usually not constant. Map out these locations now, and work carefully to maintain the correct locations so that your hangers will be plumb.

### 5. HANGER ATTACHMENT

**5.1.** Hangers are to be made from minimum 12-gauge soft-annealed galvanized steel wire or 1/16" diameter stainless or galvanized steel aircraft cable.

**5.2.** Hardware used to attach hangers to the building structure must be appropriate for the site conditions and capable of supporting a minimum of 100 pounds.

**5.3.** Wire hangers shall be secured at the structure and to the suspension system with a minimum of three wraps completed within three inches.

**5.4.** Cable hangers must be secured to the structure and to the suspension system by means of clamps or compression sleeves appropriate for the cable used and capable of supporting the design load with a safety factor of two.

### 6. INSTALL SUSPENDED MAIN BEAMS

**6.1.** Select main beams carefully, as components are fabricated to be placed in specific locations within the installation.

**6.1.1.** Main beams are connected end-to-end by means of factory-applied splices.

**6.1.2.** Ends of main beams that terminate at perimeter trim will have holes for Perimeter Trim Clips (AXCCLT) attachment. Use pliers to grab the insertion tab, and twist clip into place.

**6.2.** Suspend the rows of main beams that will have hangers attached.

## 7. INSTALL THE STRONGBACK™

7.1. Prepare the StrongBack bars as follows:

7.1.1. Bend open one side of the notch that is located 12" from the end of the bar, and additional notches spaced 24" O.C.

Bend all notches in the same direction.

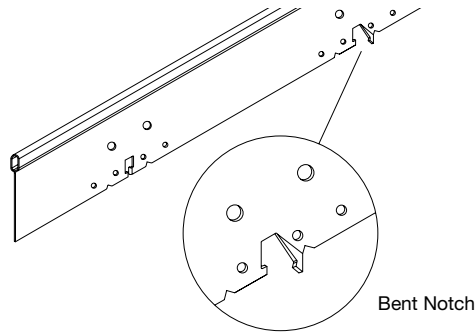

7.2. Place a StrongBack bar over the suspended main beams.

7.3. Lock the StrongBack bars to the main beams by straightening the bends made in Step 7.1.

7.4. Install any remaining rows of main beams (those that are not supported by hanger wires).

## 8. INSTALL INTERIOR CROSS TEES

8.1. Install only the cross tees that connect one main beam to another. Perimeter tees will be added later.

8.2. Insert the concealed tees into the normal rout holes (not those that are raised 1/8" higher).

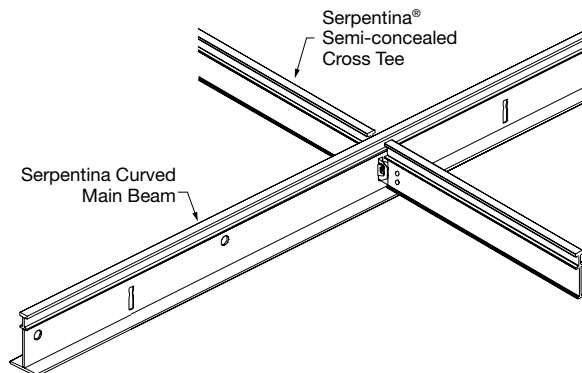

8.3. Attach the StrongBack bars to the cross tees by inserting screws through the holes provided near each end of each tee.

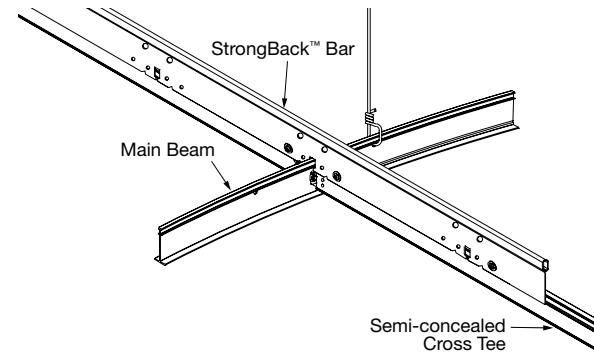

## 9. INSTALL PERIMETER CROSS TEES

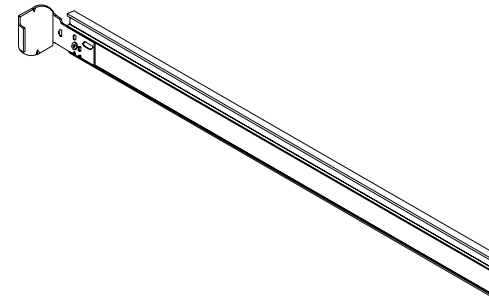

9.1. Attach the perimeter cross tees to the main beams.

9.1.1. Align the tee so that it is parallel to the bottom edge of the StrongBack, and insert a screw through the hole nearest the end of the StrongBack bar.

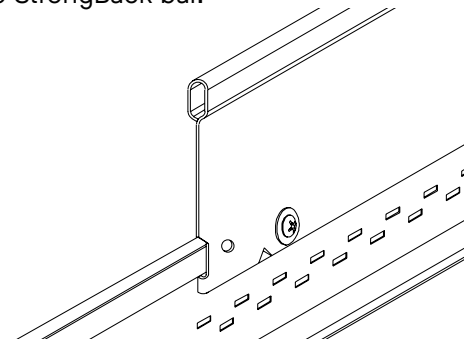

## 10. INSTALL CURVED PERIMETER TRIM

**10.1.** Attach the perimeter trim that will be parallel to the main beams as follows:

- 10.1.1.** Twist each cross tee in the counterclockwise direction, and engage the Perimeter Trim Clip (AXCCLT) clip into the grooves in the trim.
- 10.1.2.** Rotate the clips back to vertical, and align to the reference marks you made on the trim (see Section 2).
  - Rotate the clips back to vertical, by holding the insertion tab with pliers.
- 10.1.3.** Attach additional sections of trim as required, inserting a Splice Plate (SPTSPLICE) at each joint.
  - Use care when tightening the setscrews. Excessive force will deform the face of the perimeter trim.

## 11. INSTALL STRAIGHT PERIMETER TRIM (ONE SIDE ONLY)

**11.1.** Install the sections of straight perimeter trim that run perpendicular to the main beams on just one side of the cloud. The opposite side will remain open until after the panels have been installed. Panel installation will be easiest if this side is curving toward the floor.

- 11.1.1.** Align the end of the grid with the reference marks made on the perimeter trim (Section 2). Use a screwdriver or similar tool to tap the clip into position.
- 11.1.2.** Snug up the set screws on the corner posts to complete the grid assembly.
  - Attach the Perimeter Trim Clips (AXCCLT) to the ends of the main beams by inserting screws into pre-drilled holes located on the main beam. Use care when tightening the set screws. Excessive force will deform the face of the perimeter trim.

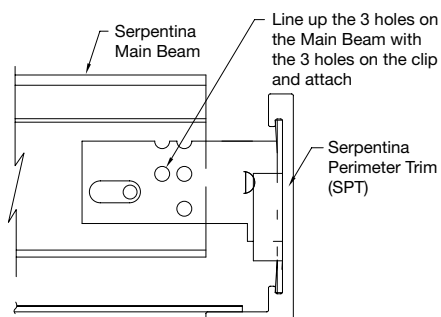

## 12. INSTALL PANELS AND HOLD-DOWN CLIPS

- 12.1.** Working from the open side of the installation, slide connector sleeves over the flange of the each main beam.
- 12.2.** Handle panels with care to avoid damage. Two people are recommended for this operation.
- 12.3.** Identify the perimeter panels (those with a panel hanger on one edge only).
- 12.4.** Install all panels by sliding the panel hangers into the connector sleeves.
  - 12.4.1.** For projects two or more panels in length (short sides touching), installation must be progressive. Install three speed clips on each panel-to-panel joint, and apply perimeter hold-down clips as needed.
  - 12.4.2.** Continue this pattern and speed clip installation to complete the assembly. Hold-down Clips for the last row must be installed from over the top of the perimeter trim.
- 12.5.** Insert Serpentina Perimeter Hold-down Clips (AX-SPT-HDC) along the perimeter trim as needed to maintain contact between the panel face and the flange of the trim.

## 13. COMPLETE PERIMETER TRIM INSTALLATION

**13.1.** Install the perimeter trim on the last side of the cloud by repeating the steps outlined in Section 10.

## 14. FINAL ASSEMBLY

14.1. Adjust and clean components as necessary.

14.2. Use only mild detergent and a damp cloth.

14.3. Never use abrasives or solvent.

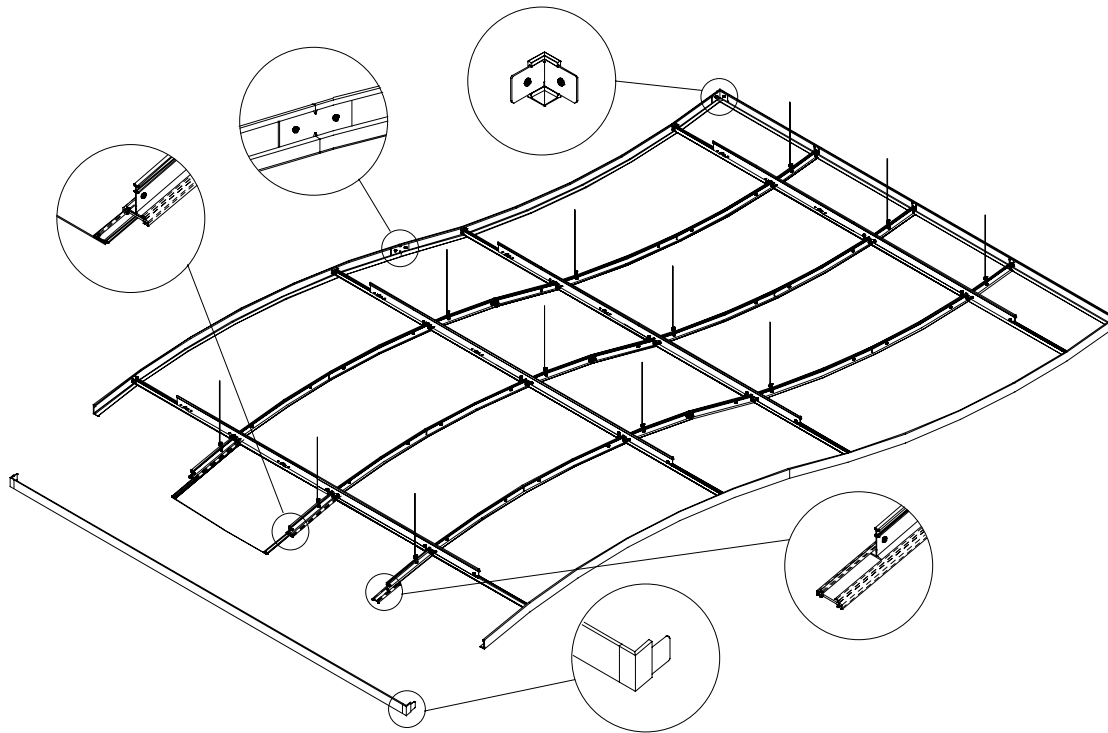

---

### MORE INFORMATION

For more information, or for an Armstrong Ceilings representative, call 877 276-7876.

For complete technical information, detail drawings, CAD design assistance, installation information, and many other technical services, call TechLine customer support at 877 276-7876 or FAX 800 572-TECH.

All trademarks used herein are the property of AWI Licensing LLC and/or its affiliates.  
© 2023 AWI Licensing Company

BPLA-297436-1023



**Armstrong**<sup>®</sup>  
World Industries