

SoundScapes® Blades Linear Acoustical Panels

Assembly and Installation Instructions

DO NOT REMOVE SOUNDSCAPES® BLADES PANELS FROM THE CARTON UNTIL YOU HAVE READ THESE INSTRUCTIONS IN THEIR ENTIRETY.

1. GENERAL

1.1 Product Description

SoundScapes® Blades panels are vertical, acoustical fiberglass panels designed to be suspended from a Prelude® XL® heavy-duty suspension system in groups, independently from cables/wires, or independently directly attached to a ceiling structure.

Additionally, SoundScapes Blades 5" panels (items 8250FO_RH05 and 8250FO_RH06) can be installed on walls. See Section 4.6 for more details.

SoundScapes Blades panels are engineered for use in seismic areas only when indicated components are used and installed in accordance with these installation instructions.

SoundScapes Blades panels are made from fiberglass and finished on all edges and surfaces (except for the top edge) with a DuraBrite® scrim or acoustically transparent membrane.

SoundScapes Blades panels are available in 20 different shapes and sizes, including rectangular panels as well as wave panel designs that have curved edges. See data page for dimensions of each panel. Additionally, custom shape panels can be ordered through the Architectural Specialties group.

There are 15 standard color options and 4 wood look finish options for the finished Blades panels. Premium and custom finishes can also be manufactured. Contact TechLine customer support, Architectural Specialties, or an Armstrong representative for additional information. Field painting will void the product warranty.

For minor surface and edge scratches on white Blades panels, use Armstrong SuperCoat™ Touch-up Paint Item #5761. This paint provides an excellent one-coat edge treatment that will blend with the original panel. For minor surface and edge scuffing, or scratches on colored Blades panels, use matching Sherwin-Williams paint that can be purchased from your local Sherwin-Williams® store.

Paint Type: Sherwin-Williams Pro Mar 200 Zero VOC – Flat		
Armstrong Color Name	Sherwin-Williams Color #	Sherwin-Williams Color Name
White (DWH)	N/A	N/A
Black (DBL)	SW6990	Caviar
Riverstone (DRV)	SW7047	Porpoise
Stone (DSE)	SW7642	Pavestone
Light Grey (DLG)	SW7044	Amazing Gray
Sandstone (DSS)	SW6119	Antique White
Oat (DOT)	SW7038	Tony Taupe
Boxwood (DBW)	SW9132	Acacia Haze
Fern (DFN)	SW6193	Privilege Green
Ivy (DIV)	SW6468	Hunt Club
Ocean (DOC)	SW6244	Naval
Twilight (DTT)	SW6250	Granite Peak
Rainstorm (DRS)	SW6516	Down Pour
Mist (DMT)	SW9138	Stardew
Topaz (DTZ)	SW7701	Cavern Clay

1.2 Storage and Handling

SoundScapes® Blades panels must be stored in a dry interior location and must remain in their original cartons prior to installation to avoid damage. The cartons must be stored in a flat, horizontal position. The vertical panels should not be removed from the carton until the suspension system is installed. Proper care should be taken when handling Blades panels to avoid damage and soiling. White cotton or latex gloves are recommended for handling. It is recommended that two installers handle 94" Blades panels.

NOTE: Blades panels in colors other than white are paper wrapped. To avoid fingerprints, do not remove paper wrapping until installation is complete.

1.3 Site Conditions

SoundScapes Blades panels can be installed where the temperature is between 40°F (4°C) and 120°F (49°C). Panels cannot be used in exterior applications, where standing water is present, or where moisture will come in direct contact with the Blades panel.

1.4 SoundScapes Blades Panel Layout

SoundScapes Blades acoustic panels are available in a variety of lengths and shapes and are able to be attached to a Prelude® suspension system in groups or individually suspended using the 6655 hanging kit or Axiom® molding, as described in Section 4. Please note that panels require a minimum of 2" gap between ends of panels for best visual due to potential bowing up to 1/8".

1.5 Fire Performance

SoundScapes Blades panels may obstruct or skew the existing or planned fire sprinkler water distribution pattern or possibly delay the activation of the fire sprinkler or fire detection system. Designers and installers are advised to consult a fire protection engineer, NFPA 13, and follow their local codes for guidance on the proper installation techniques where fire detection or suppression systems are present.

1.6 Safety Considerations – Working with Fiberglass and Mineral Fiber Products

General Construction Site Safety Information: Precautions should be taken to ensure that handling and installation procedures are taken to minimize dust generation. It is recommended that the work site is well ventilated. If high dust levels are anticipated during installation, use an appropriate NIOSH designated dust respirator. Safety glasses and gloves are recommended during installation.

First Aid Measures: If contact occurs, flush eyes and/or skin with water for at least 15 minutes and remove contaminated clothing. Wash work clothes with warm water and mild soap. Refer to Armstrong World Industries SDS (which includes information on established occupational exposure limits), available at armstrongceilings.com/commercial

1.7 Warranty

The SoundScapes Blades system has been tested based on the installation method described in this document. Warranty will be voided if you do not follow these instructions and guidelines.

1.8 HVAC Design & Operation and Temperature & Humidity Control

Proper design for both air supply and return air, maintenance of the HVAC filters, and building interior space are essential to minimize soiling. Before starting the HVAC system, make sure the supply air is properly filtered and the building interior is free of construction dust. SoundScapes Blades are for interior use only and cannot be used where standing water is present or where moisture will come in direct contact with the ceiling.

1.9 Plenum

SoundScapes Blades panels allow downward accessibility to the plenum. Blades panels can be unattached and re-attached to grid or cable hanging kits.

Blades panels are installed below the suspension system and do not need to travel above the suspension system during installation.

Installations with grid require a minimum of 3" of space in the plenum to install the hanger wires for the suspension system.

NOTE: Light fixtures and air handling systems require more space and will determine the minimum plenum height for the installation.

1.10 Cleaning

Dust and loose dirt may be easily removed by brushing or with a vacuum cleaner. Vacuum cleaner brush attachments such as those designed for cleaning upholstery or walls do the best job. Be certain to clean in one direction only. This will prevent rubbing dust into the surface of the ceiling. Use a melamine eraser sponge to wipe off any dirt or greasy fingerprints. If this does not clean the Blades panel, cover the spot with touch up paint as described on next page. Make sure to dab the touch up paint onto the panel to match the existing texture rather than smearing or painting.

For minor surface and edge scratches on white Blades panels, use Armstrong® SuperCoat™ Touch-up Paint Item #5761. This paint provides an excellent one-coat edge treatment that will match the original vertical panel.

For minor surface and edge scuffing, or scratches on colored Blades panels, use matching Sherwin-Williams® paint that can be purchased from your local Sherwin-Williams store.

For minor scratches and scuffs on wood looks Blades, contact TechLine for support.

2. DESIGN AND INSTALLATION CONSIDERATIONS

2.1 Directionality

Ceilings

The surface of SoundScapes® Blades is a non-directional, slightly textured surface. Overall installation designs are non-directional with differences based on installation method. Blades panels installed using Prelude® suspension system will be limited to panels running parallel or 90 degrees to the main beams.

However, SoundScapes Blades panels installed with the Item 6655 hanging kit or with Axiom® molding can be installed in any direction, allowing for complete freedom in designs. See installation Section 4 for further details.

The embedded hanging clip in SoundScapes Blades with a wood look finish is black, therefore a black suspension system is recommended. Embedded hanging clips for painted Blades are white. **(Fig 1)**

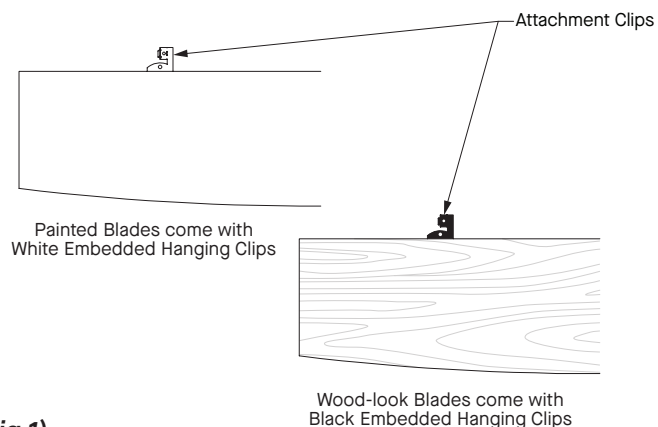

(Fig 1)

Walls

For guidelines and instructions on wall installations, see Section 4.6.

2.2 Sprinklers

SoundScapes Blades panels may obstruct or skew the existing or planned fire sprinkler water distribution pattern, or possibly delay the activation of the fire sprinkler or fire detection system. Designers and installers are advised to consult a fire protection engineer, NFPA 13, and follow their local codes for guidance on the proper installation techniques where fire detection or suppression systems are present.

The minimum drop of the SoundScapes Blades panels will be 6" drop from the plenum when using the 5" panel with the direct-attach method (AXM34STR3XX). Alternate product sizes and installation methods can have greatly varying drops.

2.3 Plenum

SoundScapes Blades panels allow downward accessibility to the plenum. Blades panels can be unattached and re-attached to grid or cable hanging kits.

Blades panels are installed below the suspension system and do not need to travel above the suspension system during installation.

Installations with grid require a minimum of 3" of space in the plenum to install the hanger wires for the suspension system.

NOTE: Light fixtures and air handling systems require more space and will determine the minimum plenum height for the installation.

2.4 Approximate System Weight and Attachment to Deck/Wall

Overall system weight will be based on the weight of the Blades panels and installation method.

SoundScapes Blades panels have an approximate weight of 1.0 LBS/SF. Based on your layout and the panels used, you will need to calculate LBS/SF for the installation method. See table on page 12 for weight per panel.

Ceiling Hanger Connections: Hanger connections to the ceiling structure must follow the fastener manufacturer's instructions and referenced code based on system weight and structure into which the suspension system will be fastened. Average system weight per square foot will depend on the design layout and must be calculated by installer.

Wall Connections: For guidelines and instructions on wall installations, see Section 4.6.

Correct mechanical fasteners must be used to install Axiom® molding and SoundScapes Blades panels directly to a wall. It is advised that connections be screwed directly to wall studs. When this is not possible, contractor must select appropriate anchors for the wall substrate as well as the weight of the system.

2.5 Accessibility

SoundScapes Blades systems are vertically mounted panels. While installed, accessibility will be limited to reaching through panels to suspension system or plenum/ceiling deck. Alternatively, Blades panels can be removed. Blades panels installed in grid rout holes can be lifted up and pulled free. Blades panels installed with screws can be unscrewed and replaced, as necessary. See installation Section 7 for further details on panel attachments to grid.

2.6 Cutting Blades Panels

SoundScapes Blades panels cannot be field cut. Contact Architectural Specialties for custom length Blades panels.

2.7 Blades Panel Layout

Minimum spacing between Blades panels depends on the installation method.

- Independent Suspension with Hanging Kits – 12" O.C.
- Attached to Grid – 6" O.C.
- Directly Attached to Axiom® Molding – 6" O.C.

3. ACCESSORIES

The installation hardware for SoundScapes® Blades panels is already included in the panel and can be used with multiple suspension options.

Four-point Hanging Kit (Item 6655)

SoundScapes Blades panels can be independently suspended using aircraft cables and quick release, fork gripper adjusters. The Item 6655 hanging kit includes: (4) 96" long cables with stops, (4) fork gripper adjusters, and (4) top end connectors. See installation Section 4.2 for further details. (Fig 2)

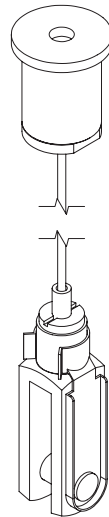

(Fig 2)

Axiom® Molding (Item AXM34STR3XX) for Direct Attach to Walls or Ceilings

SoundScapes Blades panels can be independently installed direct to a ceiling or wall surface using Axiom molding. Molding will be mostly hidden behind the Blades vertical panel, and will assist with alignment of the installation. The 360 degree painted finish ensures that the molding will be less visible upon final installation. Molding is 120" and is sold by the piece. See installation Sections 4.5 and 4.6 for further details. (Fig 3)

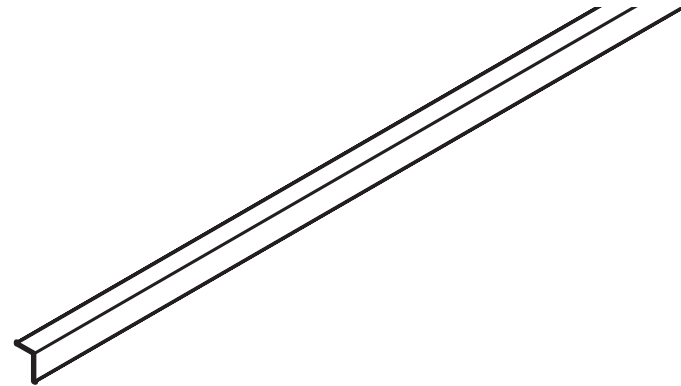

(Fig 3)

4. SUSPENSION SYSTEM

The requirements listed here represent the manufacturer's minimum acceptable installation recommendations, and may be subject to additional requirements established by the local authority having jurisdiction.

- All installations should follow ASTM C636
- All references to suspension component duty ratings are per ASTM C636
- The suspension system chosen must be fastened to the structure per code in your area

4.1 Suspension Options

There are four different types of suspension options for use with SoundScapes Blades panels. These methods are:

- Independently suspended from structure with the Item 6655 4-point hanging kit
- On a heavy-duty Prelude® XL® 15/16" suspension system in a standard 2' x 2' layout

- On a heavy-duty Prelude XL 15/16" suspension system in a "Rail" layout attached to deck by Rigid Attachment Clip (Item # 6459BL) or Adjustable Hanger Bracket (ARBRKT)
- Attached to Axiom® molding which is directly attached to structure in order to minimize the distance from the ceiling deck to the Blades. This attachment method can also be used for wall installations. See Sections 4.5 and 4.6 for further details on this installation method.

Each vertical panel has embedded attachment clips along the top of each panel. **(Fig 4)**

NOTE: All 4' and 8' panels share hardware spacing.

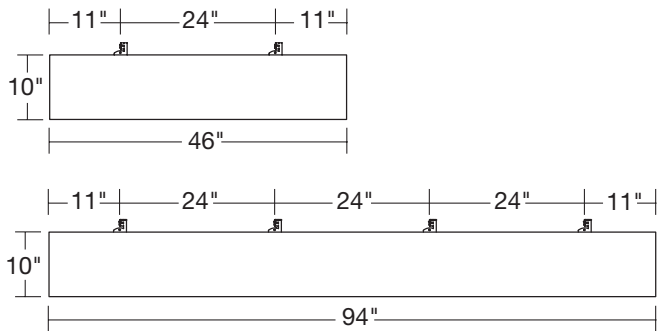

(Fig 4)

4.2 Independent Suspension with Hanging Kit

SoundScapes Blades panels can be independently suspended using aircraft cables and quick release fork gripper adjusters. **(Fig 5)** The Item 6655 hanging kit includes:

- (4) 96" long cables with stops
- (4) fork gripper adjusters
- (4) gripper structure anchors

NOTE: For layout considerations in a seismic installation, refer to Section 9.0.

- Determine the location to hang the Blades panels
- Fasten the appropriate anchor to the structure that will interface with the gripper structure anchors

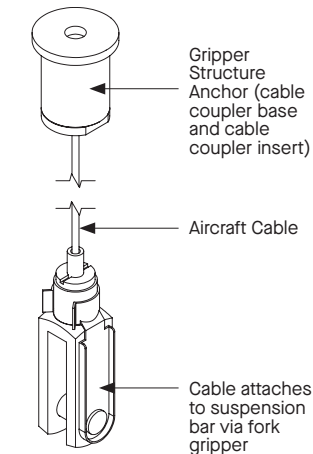

(Fig 5)

Remove the unneeded portion of the clip with tin snips **(Fig 6)**

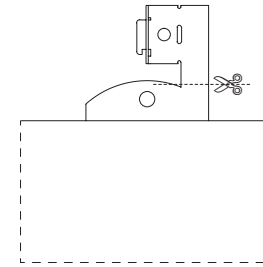

(Fig 6)

1. Attach the fork gripper and pin through the hole in the embedded attachment clip within the Blades panel. **(Fig 7)**

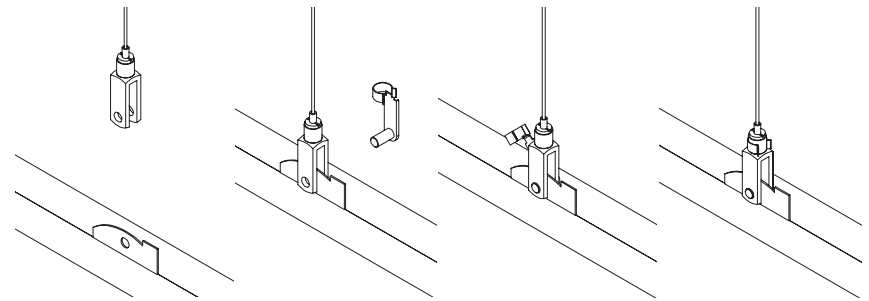

(Fig 7)

2. Thread the aircraft cable through the fork gripper with cable extending beyond the gripper by at least 1".
3. Level the Blades panel to the finished height, carefully ensuring that the cable does not scratch or puncture the Blades panel, and trim the aircraft cable at the desired length once finished.
4. To release the cable and lower the Blades panel, take all weight off the fork gripper, push the release mechanism, and simply slide the cable out as needed.

NOTE: An 8' aircraft cable is included in the standard Deck Hanging Kit. If additional cable length is needed for high ceiling applications, order the Extended Hanging Cables Kit (Item 625530), which has (4) 30' aircraft cables per kit.

IMPORTANT SAFETY AND QUALITY NOTE: Do not allow any portion of wire or aircraft cable to drop below the top of a panel while adjusting final height. Doing so could cause damage to the edge of the panel.

4.3 Group Installation on a Standard 2' x 2' Layout of Heavy-duty Prelude® XL® 15/16" Grid

SoundScapes® Blades panels can be installed on Prelude XL heavy-duty suspension system by using the embedded attachment clips on the top of the SoundScapes Blades panels that rest on the flange of the grid.

- The suspension system must use Prelude XL heavy-duty main beams (includes 360° Painted Grid) and full-height cross tees (1-11/16"). These suspension components are necessary despite the seismic design category of the installation.
- For Seismic Design Category C, D, E, and F installations refer to Section 9 Seismic Installations and the Armstrong® Seismic Rx® guide to modify the suspension system to meet IBC requirements. For seismic category A and B installations refer to the following guidelines:
- Main beams closest to the perimeter must be no farther than 24" from each wall
- Main beams must have a hanger wire within 24" of the walls, and a maximum of 4' O.C.
- The field of the suspension system assembly must be a standard 24" x 24" module build (main beams 48" O.C., 48" cross tees perpendicular to the main beams at 24" O.C., and 24" cross tees spanning the midpoints of the 48" cross tees.) Once the suspension system is in place refer to Section 4.0 Blades Panel Attachment to Suspension System. **(Fig 8)**

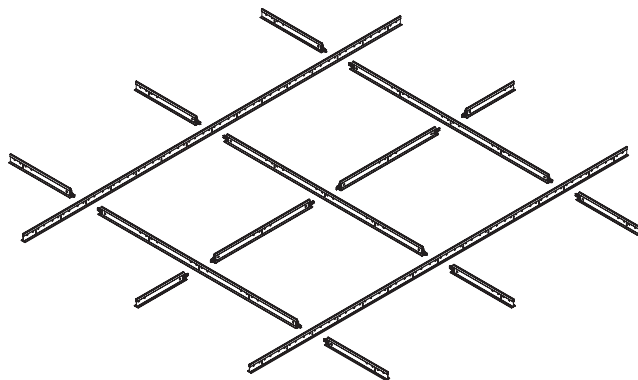

(Fig 8)

2' x 2', 4 FT O.C.

4.4 Group Installation on a "Rail" Layout of Heavy-duty Prelude® XL® 15/16" Grid

SoundScapes® Blades panels can be installed on a grid "Rail" system, using the following components:

- Prelude® XL® heavy-duty main beams (includes 360° painted grid main beams)
- Main beams must be spaced at 24" O.C.
- The rigid attachment clip (Item 6459BL) or ARBRKT brackets to attach main beams to the deck
- 2' cross tees installed at 4' or 6' O.C. for alignment and squaring **(Fig 9)**

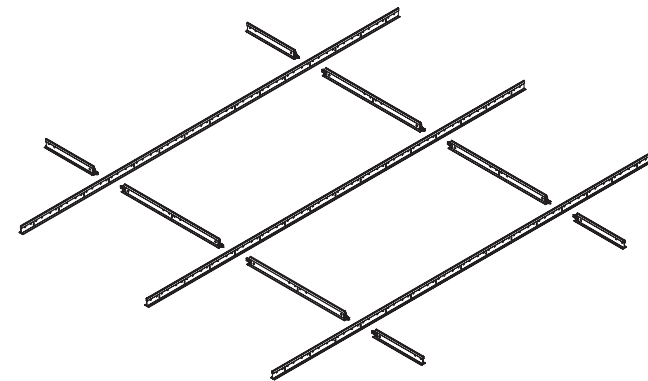

(Fig 9)

2' x 4', 2 FT O.C.

4.4.1 Brackets

Brackets are used to attach the main beams to structure. Brackets are recommended within 12" of the ends and not more than 48" O.C. along the run of main beams. Brackets allow suspension system elevation adjustment from 1-3/4" to 5-1/2". Avoid installing the bracket on the main beam at the location of cross tees.

6459BL Rigid Attachment Clip – This clip must be accurately located before fastening to the structure for correct suspension system alignment and proper panel fit. Use a string line or laser to establish a straight row for bracket attachment. Use the appropriate fastener to anchor the clip to the structure.

ARBRKT Adjustable Hanger Bracket – This bracket is adjustable after fastening to the structure with a screw. This allows flexibility and minor variations for attachment to the structure. Use of a string line or laser is still recommended for this bracket. The suspension system can easily be aligned and squared for proper panel fit. Use the appropriate fastener to anchor the clip to the structure.

4.4.2 Main Beams

Main beams will run perpendicular to the Blades panel length and will act as carrying rails. Blades panel attachment will only be to main beams, and cross tees are added only for alignment and squaring of the system.

- 7301 Prelude XL main beams are installed at 24" O.C. to align with the embedded attachment clips
- The main beams must be attached to the brackets so that cross tee rout holes are located for proper spacing of the Blades panels per the reflected ceiling plan

First Row of Main Beams:

Use clamps or vise grips to temporarily secure the first main beam to the brackets. Adjust for proper location and elevation. Use two sheet metal screws (Type #8 × 1/2" sharp point screw) to fasten the bracket to the main beam. Use the typical method to join sections of main beams for long runs.

Additional Rows of Main Beams:

Brackets should be installed accurately to accommodate 24" O.C. main beam spacing. Use clamps or vise grips to temporarily secure the main beam in the second row to the brackets. To aid in alignment and squaring of the system, use 2' cross tees. These cross tees can be installed 48" or 72" O.C., in order to avoid rout holes that are needed for attachment of the Blades panels per the RCP.

Check System Squareness:

System squareness is a critical stage of suspension system installation. System squareness must be within 1/16" for the measurement of a 24" × 48" module. The system must be square or this will result in improper panel fit, poor alignment, and an unacceptable visual. To measure diagonals use a carpenter's square, or run a laser or dry line perpendicular to the mains to align rout holes. Secure the second main beam to the brackets with sheet metal screws.

For installations with multiple rows of main beams:

Once the first two main beams are square, temporarily clamp the furthest main beam of the installation. Clamp a dry line to a reference rout hole in the furthest main beam and then pull tight and clamp to the matching rout hole in the first main beam. Adjust the furthest main beam so that the dry line intersects the rout holes of the first two squared main beams. Screw attach the furthest main beam. Next, install all remaining main beams within the field of the installation so that the rout holes intersect the dry line. This will ensure proper alignment throughout the installation.

Trim off any excess main beam ends to keep the main beam concealed.

4.4.3 Cross Tees

Continue to install the remaining 24" cross tees at 48" O.C. throughout the rest of the installation. Since the main beams are secured with rigid brackets, you may need to roll the top bulb away to ease insertion of the cross tee clip. All single tee connections at the perimeters will need to be reinforced with an STAC clip for both seismic and non-seismic installations. (Fig 10)

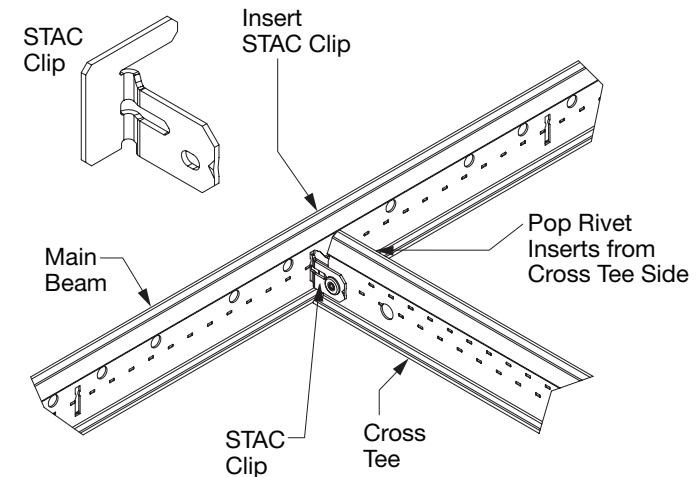

(Fig 10)

4.5 Direct Attach with Axiom® Molding for Ceilings

See Pictorial Installation Instructions in the Appendix
SoundScapes® Blades panels can be directly attached to Axiom® molding that is fastened to a ceiling structure using the following components:

- Axiom molding (AXM34STRXX)
- Fasteners for Blades panels to Axiom molding attachment (#8 × 7/16" self-drilling wafer head screws, provided by contractor)
- Appropriate fastener for Axiom molding to structure connection (specified and provided by contractor) based on the weight of the panels (1 LB/SF) and the ceiling substrate.

4.5.1 Axiom Molding to Ceiling Structure

Axiom molding (AXM34STRXX) comes in 10' lengths and can butt end to end for long runs of Blades panels. When terminating a row, the molding can be cut to match the length of the panel it is suspending. The molding can be cut with tin snips or a circular saw.

Each piece of Axiom molding must be attached to structure at 16" - 24" O.C. and within 12" of the ends. The attachment must be made with the appropriate fastener based on the material the molding is being attached to (i.e. steel framing, concrete, etc.) and the weight it must hold. The molding should be pre-drilled to facilitate the fastener connection.

The Axiom molding must be installed flush to the ceiling and can be installed on up to a 30-degree slope, with the molding and panels running up the slope.

See Appendix for detail drawings of Direct Attach Installation.

4.5.2 Blades Panels Attachment to Axiom Molding (Ceiling)

For direct attachment to the Axiom molding the top portion of the embedded attachment clip must be cut off with tin snips. **(Fig 11)**

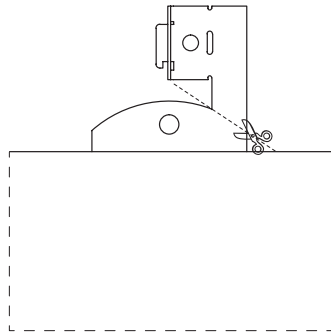

(Fig 11)

- The embedded attachment clip should be placed on the inside edge of the molding with the back (unfinished) edge of the blade pressed up against the molding. **(Fig 12)**

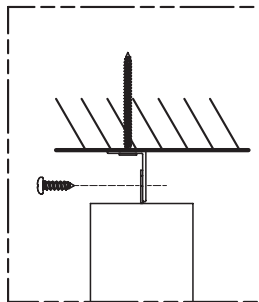

(Fig 12)

- Screws must go through the pilot hole in the embedded attachment clip first, and then into the Axiom® molding.
- Blades panels are screw-attached to the Axiom molding with #8 x 7/16" self-drilling wafer head screws (provided by contractor).
- Screw attachments must be made at each embedded hardware location along the panel (two per 46" panel, and four per 94" panel).
- Screw tips may be visible based on spacing of Blades panels and viewing angle. Flexible 1/8" - 3/16" screw thread protectors can be used to cover screw points coming through the Axiom® molding. These are optional and provided by the contractor.
- Screw heads for the Axiom molding to wall attachment and Blades panels to Axiom molding may be visible based on panel spacing and viewing angle. Touch up paint (provided by contractor) to match the Axiom molding and embedded hardware can be used in these scenarios.
- Blades panels should not be installed with less than 2" between ends.
- Minimum spacing between rows of Blades panels is 6" O.C.
- Spacing between rows and depth of the Blades panels may require a progressive installation.

4.6 Direct Attach with Axiom Molding for Walls (5" Blades panels only)

See Pictorial Installation Instructions for Direct Attach in the Appendix. SoundScapes® Blades 5" panels (8250FO_RH05 and 8250FO_RH06) can be directly attached to Axiom molding that is fastened to a wall structure using the following components:

- Axiom molding (AXM34STR3XX)
- Fasteners for Blades panels to Axiom molding attachment (#8 x 7/16" self-drilling wafer head screws, provided by contractor)
- Appropriate fastener for Axiom molding to structure connection (specified and provided by contractor) based on the weight of the panels (1 LB/SF) and the wall substrate.

NOTE: All 5" panels being installed on the wall should be attached no less than 7' above the floor.

4.6.1 Axiom Molding to Wall Structure

Axiom molding (AXM34STR3XX) comes in 10' lengths and can butt end-to-end for long runs of Blades panels. When terminating a row, the molding can be cut to match the length of the blade panel it is suspending. The molding can be cut with tin snips or a circular saw.

Each piece of Axiom molding must be attached to structure at 16 - 24" O.C. and within 12" of the ends. The attachment must be made with the appropriate fastener based on the material the molding is being attached to (i.e. steel framing, concrete, etc.) and the weight it must hold. Item 8250FO_RH05 – 46" Blades panels weigh approximately 1.52 LBS each, and Item 8250FO_RH06 – 94" Blades panels weigh approximately 3.25 LBS each. The molding should be pre-drilled to facilitate the fastener connection.

The Axiom molding must be installed flush to the wall and can be installed at angles up to 30 degrees off of vertical. All wall installations should be installed at least 6' above finished floor or higher to avoid damage. (Fig 13)

Blades panels should never be installed horizontally to the floor or used as a support for other weight.

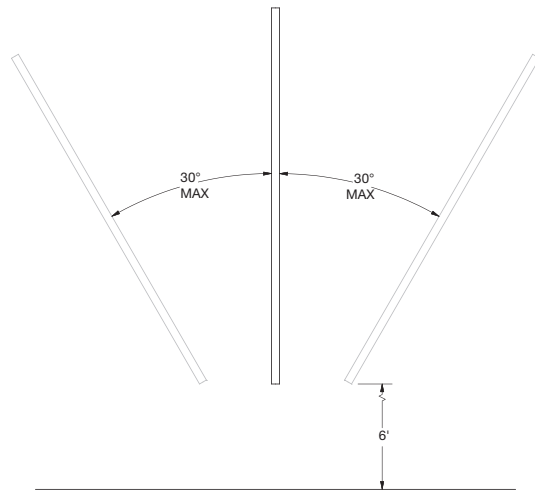

(Fig 13)

4.6.2 Blades Panels Attachment to Axiom® Molding (Wall)

For direct attachment to the Axiom molding the top portion of the embedded attachment clip must be cut off with tin snips.

Please note: Cut the panel hardware on an angle to mirror the shape of the rounded portion of the hardware for best clean-cut results. Installer should ensure that sharp edges are not accessible to building occupants. (Fig 14)

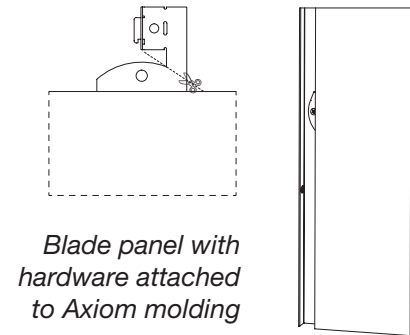

(Fig 14)

- The embedded attachment clip should be placed on the inside edge of the molding (see section detail) with the back (unfinished) edge of the blade panel pressed up against the molding.
- Screws must go through the pilot hole in the embedded attachment clip first, and then into the Axiom molding.
- Blades panels are screw attached to the Axiom molding with #8 x 7/16" self-drilling wafer head screws (provided by contractor).
- Screw attachments must be made at each embedded hardware location along the Blades panel (two per 46" panel, and four per 94" panel).
- Screw tips may be visible based on spacing of Blades panels and viewing angle. Flexible 1/8" - 3/16" Screw thread protectors can be used to cover screw points coming through the Axiom molding. These are optional and provided by the contractor. Installer is responsible to ensure that sharp points are not accessible to building occupants. (Fig 15)

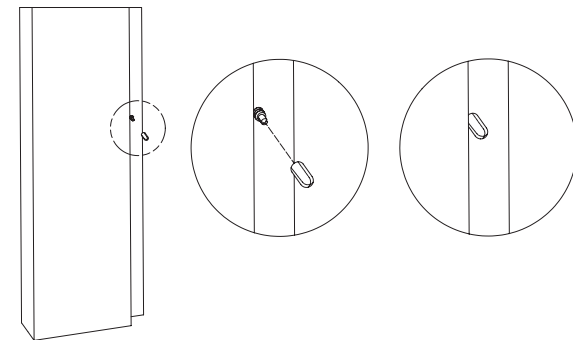

(Fig 15)

- Screw heads for the Axiom molding to wall attachment and Blades panels to Axiom molding may be visible based on spacing of Blades panels and viewing angle. Touch up paint (provided by contractor) to match the Axiom molding and embedded hardware can be used in these scenarios.
 - Blades panels should not be installed with less than 2" between ends.
 - Minimum spacing between rows of Blades panels is 6" O.C.
 - Spacing between rows and depth of the Blades panels may require a progressive installation.

5. FLOATING PERIMETER/TRIM FOR DISCONTINUOUS SYSTEMS

For discontinuous grid installations Axiom® trim can be used to provide a professional, finished aesthetic around the grid.

It is recommended that Axiom interfaces at the grid level because SoundScapes® Blades hang at various elevations below the face of the grid system. **(Fig 16)**

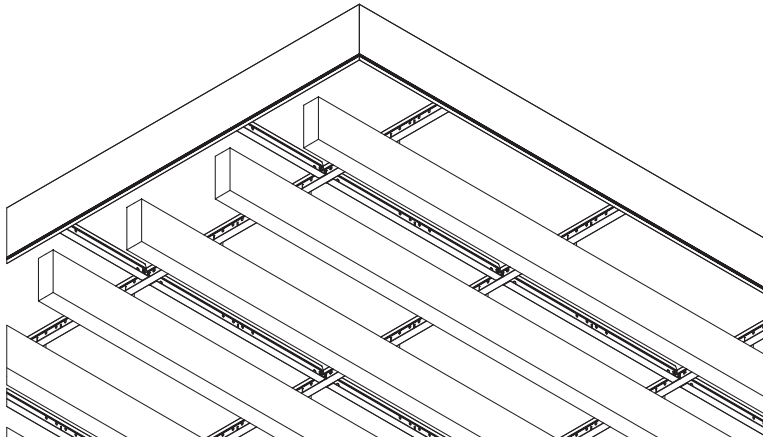

(Fig 16)

6. TRANSITIONS

SoundScapes Blades can be installed adjacent to other ceiling types or in conjunction with other ceilings. Transitions to a SoundScapes Blades installation can be made similarly to a traditional acoustical grid ceiling but must account for the elevation drop of the Blades panels below the suspension system.

7. BLADES PANEL ATTACHMENT TO SUSPENSION SYSTEM

The Blades panels can be installed by aligning the embedded attachment clip into the rout holes in the Prelude® XL® main beams. The 6" O.C. rout holes in the suspension system act as alignment and spacing indicators. Additional measuring and modifying of the suspension or embedded attachment clip is necessary when installing Blades panels off the 6" O.C. rout holes. In cases where the clip does not align with a rout hole, the clip can be modified and screw-attached as detailed in the note below:

Always consider load and swinging of vertical panels for any installation type. A 6" O.C. minimum spacing is recommended for all standard SoundScapes Blades panels installed on a Prelude XL suspension system.

1. Align the clip tabs on the embedded hardware in the appropriate rout holes of the suspension system.
2. Once the tabs are engaged, Blades panels will be level and ready to secure to the suspension system.
3. Attach to the suspension system with a short framing screw through the clip convenience hole and the web of the grid. One screw per Blades panel if the installation is Seismic Category A or B. One screw at each hardware-to-suspension connection if the installation is Seismic Category C, D, E, or F. **(Fig 17)**

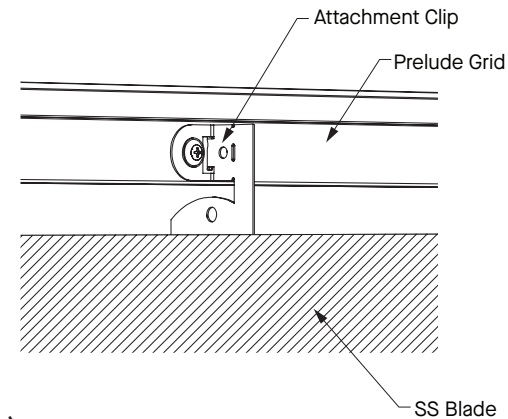

(Fig 17)

NOTE: In order to install Blades panels in a location where a rout hole is not present to accept the clip tab, use aviation snips to cut off the tab on the embedded hardware so that the remaining hardware can press firmly against the web of the suspension system. Once aligned, simply drive a short framing screw through each clip convenience hole at the location desired along the suspension system component. (Fig 18)

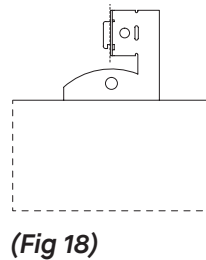

7.1 Attached to Axiom® Molding That is Directly Attached to Ceiling Structure

SoundScapes® Blades panels can be directly attached to Axiom molding that is fastened to structure using the following components:

- Axiom molding (AXM34STR3XX)
- Fasteners for Blades panels to molding attachment (#8 × 7/16" self-drilling wafer headscrews, provided by contractor).
- Appropriate fastener for Axiom molding to structure connection (provided by contractor).

Refer to Sections 4.5.2 and 4.6.2 for more details.

8. SPECIAL INSTALLATION CONSIDERATIONS

8.1 Sloped Installations

The following rules apply to sloped installations for SoundScapes Blades and are based on the installation method:

Independent Suspension with Hanging Kit

Blades panels should not be sloped and are intended for the bottom edge to be on a horizontal plane. This applies to all Seismic Design Categories.

Attached to Prelude® Grid

Blades panels should not be installed on sloped grid. This applies to all Seismic Design categories.

Directly Attached to Axiom Molding

When directly attached to Axiom molding, Blades panels can be installed on up to a 30-degree slope as long as the Blades panels and Axiom molding are running up the slope.

Ceilings with a slope angle >30 degrees require project specific engineering, which is the design team's responsibility. This applies to all Seismic Design categories.

8.2 MEP Integration

Mechanical fixtures such as lights, speakers, and sprinklers should be installed into the acoustical suspension system before installing the SoundScapes® Blades panels. Fixtures can be installed at the suspension system height or flush with the bottom of the panels (refer to Section 1.5 for sprinkler considerations). Fixture weight or housing must not be supported by the Blades panels.

8.3 Exterior Installations

SoundScapes Blades cannot be installed in exterior installations.

9. SEISMIC INSTALLATIONS

The following are modifications to installations that are Seismic Category C, D, E, or F.

For more details on seismic installations please see our brochure: [Seismic Design: What You Need to Know](#)

9.1 Aircraft Cable Installation

The International Building Code states the ceiling system connection to structure must allow the ceiling to move 360° in horizontal plane. Blades panels suspended individually with aircraft cable must be spaced a minimum of 12" apart or from surrounding surfaces to avoid contact during a seismic event.

9.2 Grid Suspension System:

- All seismic installations of SoundScapes® Blades panels must be installed per Seismic Categories C, D, E, F. This is regardless of the total system weight.
- Prelude® heavy-duty grid is required per ASTM E580 and the cross tees may have to match the mains in load-carrying capacity based on the grid layouts as defined in Section 4.
- SoundScapes Blades directly attached to grid have been engineered for application in all seismic areas.
- One screw is required at each embedded hardware-to-grid connection.

10. DIRECT-ATTACH INSTALLATION

- 1) Using metal snips, cut the SoundScapes® Blades hardware and the Axiom® molding to the desired length (matching the length of the Blades panel looks great.)

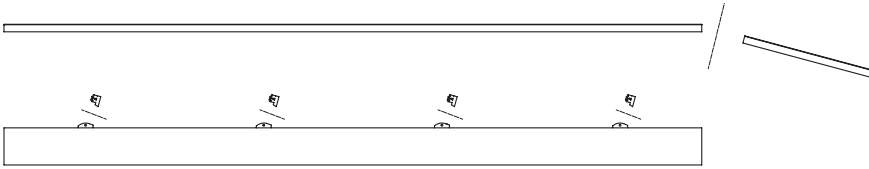

- 2) After marking specified location of the Blades panel on the wall or ceiling, attach the 3/4" face of the Axiom molding using appropriate fasteners for the surface type.

Drywall screw anchors will work well when studs aren't easily located.

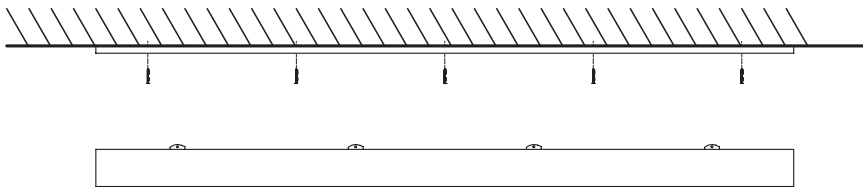

- 3) Lastly, screw the SoundScapes Blades panel hardware to the 1" surface of the Axiom molding. Consider coordinating screw color to match the 360° degree painted Axiom molding.

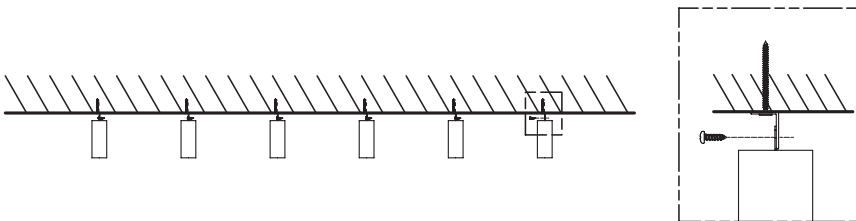

SoundScapes® Blades Acoustical Panel Items						
Item No.◆	Item Name	Included with panels	Sold by the:	PCS/CTN	LBS per panel Wood-Looks	LBS per panel Colors
8250FO_RH05_ _ _	Rectangular Vertical Panel – 5 × 46 × 2"	–	carton	4	2.9	2.2
8250FO_RH06_ _ _	Rectangular Vertical Panel – 5 × 94 × 2"	–	carton	4	5.8	4.3
8250FO_RH01_ _ _	Rectangular Vertical Panel – 10 × 46 × 2"	–	carton	4	5.1	3.6
8250FO_RH02_ _ _	Rectangular Vertical Panel – 10 × 94 × 2"	–	carton	4	10.3	7.2
8250FO_RH07_ _ _	Rectangular Vertical Panel – 16 × 46 × 2"	–	carton	4	7.8	5.4
8250FO_RH08_ _ _	Rectangular Vertical Panel – 16 × 94 × 2"	–	carton	4	15.6	10.6
8250FO_RH03_ _ _	Rectangular Vertical Panel – 22 × 46 × 2"	–	carton	4	10.5	7.2
8250FO_RH04_ _ _	Rectangular Vertical Panel– 22 × 94 × 2"	–	carton	4 or 2	20.9	14.1
8250FO_RH09_ _ _	Rectangular Vertical Panel – 28 × 46 × 2"	–	carton	4	13.1	8.9
8250FO_RH10_ _ _	Rectangular Vertical Panel – 28 × 94 × 2"	–	carton	4 or 2	26.2	17.6
8250FO_CH01_ _ _	Hill Vertical Panel – 7-1/2 × 46 × 2"	–	carton	4	4	2.9
8250FO_CH03_ _ _	Hill Vertical Panel – 19-1/2 × 46 × 2"	–	carton	4	9.4	6.4
8250FO_CH02_ _ _	Valley Vertical Panel – 10-1/2 × 46 × 2"	–	carton	4	5.4	3.8
8250FO_CH04_ _ _	Valley Vertical Panel – 22-1/2 × 46 × 2"	–	carton	4	10.7	7.3
8250FO_WH01_ _ _	Wave Vertical Panel – 10-1/2 × 94 × 2"	–	carton	4	10.7	7.5
8250FO_WH02_ _ _	Wave Vertical Panel – 22-1/2 × 94 × 2"	–	carton	4 or 2	21.3	14.4
8250FO_WH03_ _ _	Wave Vertical Panel – 10 × 46 × 2"	–	carton	4	5.1	3.6
8250FO_WH04_ _ _	Wave Vertical Panel – 22 × 46 × 2"	–	carton	4	10.5	7.2
8250FO_WH05_ _ _	Double Wave Vertical Panel – 10 × 94 × 2"	–	carton	4	10.3	7.2
8250FO_WH06_ _ _	Double Wave Vertical Panel – 22 × 94 × 2"	–	carton	4 or 2	20.9	14.1

◆ Add a number suffix for blades that will have a color (3) or have a Wood Look (4) finish and 3 letter suffix for the actual finish (e.g., 8250FO3RH03DWH = A color blade that's painted White or 8250FO4RH03WHO = A wood look blade in Honey Oak finish)

SoundScapes Blades Acoustical Panels Suspension and Accessories				
Item No. ♦	Item Name	Included with panels	Sold by the:	PCS/CTN
For Group Suspension				
7301	12' HD Main Beam	no	carton	20
XL7342	4' Cross Tee	no	carton	60
XL7328	2' Cross Tee	no	carton	60
7800	12' Angle Molding	no	carton	30
6459BL	Rigid Attachment Clip	no	carton	25
ARBRKT	Adjustable Hanger Bracket	no	carton	80
STAC	Single Tee Adapter Clip	no	carton	120
For Group Suspension – 360° Painted Grid				
56418	12' HD Main Beam – 360° Painted Grid	no	carton	20
56421	4' Cross Tee – 360° Painted Grid	no	carton	60
56419	2' Cross Tee – 360° Painted Grid	no	carton	60
7800	12' Angle Molding	no	carton	30
For Individual Suspension				
6655	4-Point Hanging Kit (4 Suspension Points)	no	bag	4 per bag
AXM34STR3XX	Axiom Molding 360° (for Direct Attach)	no	piece	(360° Paint Recommended; order by the piece)
625530	Extended Hanging Cables (30' Aircraft Cable)	no	bag	4 per bag

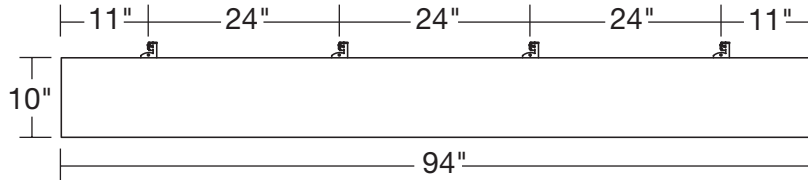
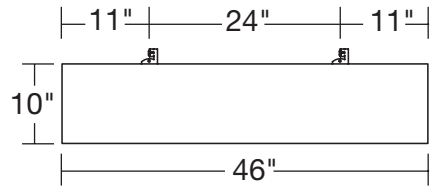

*NOTE: All 4' and 8' panels have the same hardware (clip) spacing.
To see drawings of all SoundScapes® Blades panels,
see data page.*

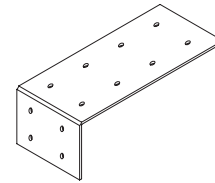

*Rigid Attachment
Clip – 6459BL*

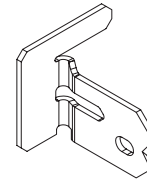

*Single Tee
Adapter Clip –
STAC*

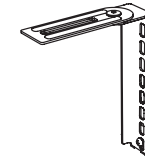

*Adjustable
Hanger Bracket –
ARBRKT*

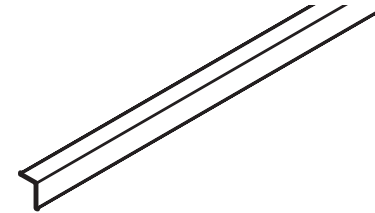

AXM34STR3XX

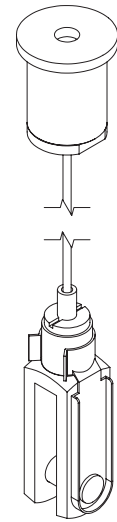

*4-Point Hanging
Kit – 6655*

MORE INFORMATION

For more information, or for an Armstrong Ceilings representative, call 1 877 276-7876.
For complete technical information, detail drawings, CAD design assistance, installation information, and many other technical services, call TechLine customer support at 1 877 276-7876 or FAX 1 800 572-TECH.

Sherwin-Williams® is a registered trademark of The Sherwin-Williams Company
All other trademarks used herein are the property of AWI Licensing LLC and/or its affiliates.
© 2024 AWI Licensing Company Printed in the United States of America

BPLA-297844-524



Armstrong®
World Industries