

WOODWORKS® Channeled Vector®

Assembly and Installation Instructions

1. GENERAL

1.1 Product Description

WoodWorks Channeled Vector ceiling panels consist of perforated, veneered 2' x 2' panels and Images™ finished panels in 2' x 2', 2' x 4', 1' x 4', and 30" x 30". Both types of panels are designed to be installed on a conventional 15/16" T-Bar suspension system. All full panels can be removed and reinstalled without the need for access to the plenum. Only two sides support installed panels. These edges have specially designed kerf details, which allow one edge of the panel to be raised slightly off of the suspension system flange, and then moved out of position. The other two sides are fitted with rabbeted edges, which work to center the panel within the suspension system opening.

1.2 Surface Finish

Natural Variations™ finished panels are constructed of MDF bonded together between two layers of wood veneer finish. All exposed edges are banded with the same finish as the face.

Panels with Images finish are constructed of MDF with a visual printed directly to the panel and a semigloss coating. All exposed edges are banded with the same finish as the face.

1.3 Storage and Handling

Ceiling components should be stored in a dry interior location and shall remain in cartons prior to installation to avoid damage. The cartons should be stored in a flat, horizontal position.

The protectors between panels should not be removed until installation. Proper care must be taken when handling to avoid damage and soiling. Do not store in unconditioned spaces with humidity greater than 55% or lower than 25% RH and temperatures lower than 50°F or greater than 86°F. Panels must not be exposed to extreme temperatures; for example, close to a heating source or near a window where there is direct sunlight. NOTE: Vector panels feature exposed edges. Exercise appropriate care to avoid unnecessary contact with the panel edges. Remember that the suspension system flanges will not conceal panel edge damage.

1.4 Site Conditions

WoodWorks Channeled Vector ceiling should be permitted to reach room temperature and have a stabilized moisture content for minimum of 72 hours before installation. (Remove plastic wrap to allow panels to climatize.) They should not, however, be installed in spaces where the temperature or

humidity conditions vary greatly from the temperatures and conditions that will be normal in the occupied space.

1.4.1 HVAC Design and Operation

Proper design for both supply air and return air, maintenance of the HVAC filters, and building interior space are essential to minimize soiling. Before starting the HVAC system, make sure air supply is properly filtered and the building interior is free of construction dust.

1.4.2 Temperature and Humidity During Installation

WoodWorks panels are interior finish products designed to be installed in temperature conditions between 50°F and 86°F, in spaces where the building is enclosed, and HVAC systems are functioning and will be in continuous operation. Relative humidity should not fall below 25% or exceed 55%. There shall be proper ventilation of the plenum in high moisture areas. All plastering, concrete, terrazzo, or any other wet work should be completely dry. All windows and doors should be in place. The heating, ventilating, and air-conditioning system should be installed and operable where necessary to maintain proper temperature and humidity conditions before, during, and after installation of the WoodWorks panels.

1.4.3 Plenum

Installation of Vector panels requires a minimum of space in the plenum, primarily that which is required to install the hanger wires for the suspension system. Three inches (3") is generally accepted as the minimum practical space that is needed to attach these wires. **NOTE:** Light fixtures and air handling systems require more space and will determine the minimum plenum height for the installation.

1.5 Color

WoodWorks panels with Natural Variations finishes are made with a variety of real wood veneers. Natural variations in color and grain are characteristic of wood products. To maximize visual consistency, panels should be unpacked and examined collectively to determine the most desirable arrangement for installation. Where consistency is critical, Armstrong can offer custom solutions to meet your budget and aesthetic requirements. Consult HPVA for additional information on veneers and veneer grades.

WoodWorks panels with Images finishes are high quality visual reproductions of wood printed directly onto MDF. A pattern repeat occurs approximately once every 29". To maximize visual consistency, panels should be unpacked and examined collectively to determine the most desirable arrangement for installation.

2. PANEL EDGES

2.1 General

The edges of the Vector® panels feature unique detailing. The following section is intended to define and explain the function of the edge details.

2.2 Access Kerf Edge

The panel edge designated as "A" has a stepped groove detail and is called the access kerf. This edge is the first to engage the suspension system. Review the drawings below to familiarize yourself with this unique detail. Remember that the "A" edge is always installed first. This panel edge is also the one that must rise when the ceiling must be accessed.

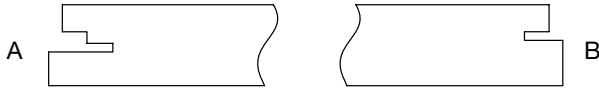

2.3 Registration Kerf

Edge "B" has a single kerf detail that supports the second side and centers the panel in the A – B direction. This edge is referred to as the registration kerf and is opposite edge "A".



2.4 Reverse Tegral Edges

The two remaining panel edges are rabbeted to fit between the flanges of the suspension system. These edges center the panel in the C – D direction and are called reverse Tegral edges.

3. SUSPENSION SYSTEM

3.1 General

The suspension system shall be standard 15/16" exposed tee grid. The installation shall, in all cases, conform to ASTM C636 requirements and the International Building Code. Because these panels weigh in excess of 2.5 lbs/SF, the ceilings shall be installed per IBC Seismic Design Categories D, E, and F. Additionally, walls or soffits that serve to support a panel edge must be braced to structure so as not to allow movement greater than 1/8" when subjected to design lateral force loads. The requirements listed here represent the manufacturer's minimum acceptable installation recommendations, and may be subject to additional requirements established by the local authority having jurisdiction.

3.2 Load Capacity

WoodWorks® Channeled Vector veneered ceiling panels weigh 2.75 lbs/SF; WoodWorks Channeled Vector Images™ finished ceiling panels weigh 2.2 lbs/SF. Main beams must be capable of carrying the weight of the panels plus any additional ceiling components that are not independently supported from the building structure. Heavy-duty components are recommended. The minimum acceptable load capacity for the main beam, when supporting only ceiling panels, is 12 lbs/LF, and the 4' cross tees must be capable of carrying a minimum of 6 lbs/LF.

3.3 Suspension System

The suspension system for 2' x 2' Vector panels shall consist of main beams spaced 48" on center. The 48" cross tees shall intersect the main beams at 90 degrees every 24". The 24" cross tees shall be installed at the midpoints of the 48" tees.

3.2.1 The suspension system for 1' x 4' panels shall consist of main beams installed at 48" centers. The 4' cross tee may be installed parallel or perpendicular to the main beams.

3.2.2 The suspension system for 2' x 4' panels shall consist of main beams installed at 2' centers with 2' cross tees completing the assembly.

3.2.3 The suspension system for 30" x 30" panels shall consist of main beams installed every 30" on center with 30" cross tees completing the assembly.

3.2.4 In all cases, the suspension system must be leveled to within 1/4" in 10' and must be square to within 1/16" in 2'. Installation on suspension systems that do not meet this tolerance will produce unacceptable panel alignment.

3.4 Safety Clips

The weight of the panels and the downward nature of the access suggest the need for a mechanism to prevent panels from dropping when disengaged from the suspension system. Two safety clips are provided for each panel. These clips must be attached to each panel by means of the #8 x 9/16" screws provided. Pre-drilled pilot holes are located along each kerfed edge of the panel. Use the hole closest to the hook for Channeled panels.

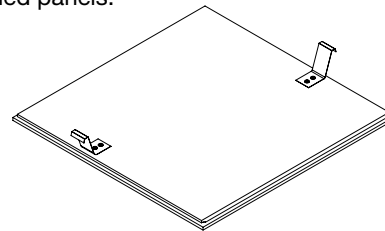

3.5 Seismic Hold Down Clips

Seismic Hold Down Clips are recommended for all installations. Two clips are required for each panel and are included in the carton. Clips should be applied to the suspension system before the placement of the panels, and should be located near ends of the kerfed edges (see Figure 1 on page 5)

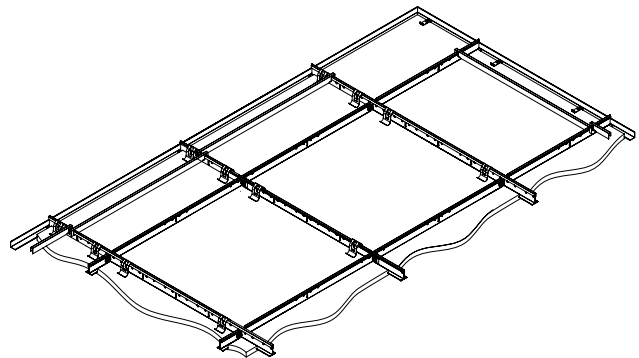

3.6 Panel Face Offset

The face of the Vector panel extends 7/16" below the suspension system. The height of components that interface with the ceiling panels, such as sprinkler heads and light fixture trim rings, will have to be adjusted to accommodate this 7/16" offset.

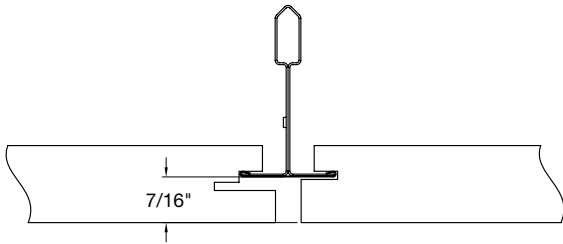

3.7 Panel Penetrations

Holes cut for sprinkler heads and other services that penetrate the ceiling panel must be cut slightly oval shaped to allow the panel to move 1/4" in the direction of the "A" edge. Additionally, trim rings for these devices must be wide enough to accommodate this 1/4" movement.

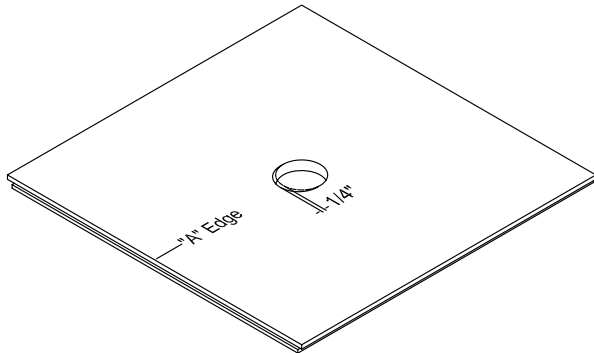

4. PANEL INSTALLATION AND REMOVAL

4.1 General

Vector® ceiling panels are easily installed and removed from below the suspension system without the aid of tools or special equipment, allowing easy downward access to the plenum.

4.2 Installing Full-size Panels

The Vector panels are installed in a simple three-step process.

STEP 1: Fully insert the deepest kerf of edge "A", the access kerf, onto the exposed suspension system flange.

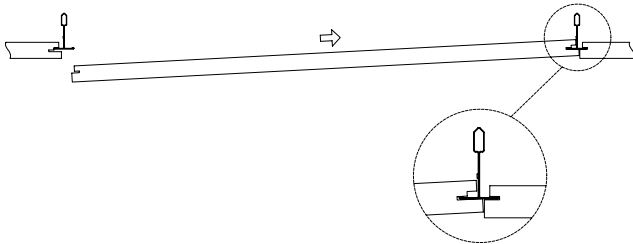

STEP 2: Raise the "B" edge of the panel, the registration kerf, into the suspension system opening until the kerf lines up with the suspension system flange.

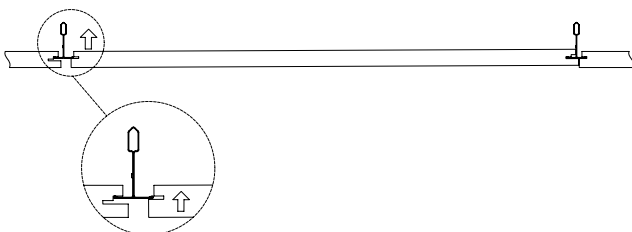

STEP 3: Slide the panel so that the registration kerf on edge "B" engages the suspension system flange. Ensure that the access kerf on edge "A" drops down into the correct position.

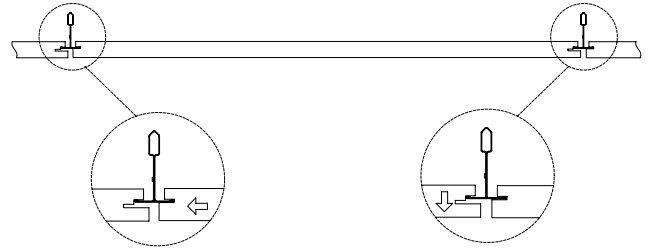

4.3 Orientation of Full-size Panels

Install all full-size panels with the "A" edge facing in the same direction to provide access consistency. Align panels as you proceed to ensure a uniform reveal width in both directions. Pay particular attention to this alignment process. Minor variations in placement can be difficult to see from the scaffold, but will become obvious when looking down long runs of panels.

4.4 Panel Removal

Press against the panel face to identify the edge that raises easily. This is the "A" edge. Move the "A" edge up and toward the web of the grid member until the "B" edge disengages and drops out of the ceiling plane.

5. PERIMETER DETAILS

5.1 General

Perimeters must be detailed as described in the following section.

5.2 Suspension System Resting on Perimeter Trim

The face of the suspension system components rests directly on the molding or trim flange. The border panels are cut to butt against the molding as shown here. The grain pattern on the panels dictates that they can be rotated 180°, but not 90°. Cutting borders will require two different techniques, one to use when the kerfs are perpendicular to the wall and another when they are parallel.

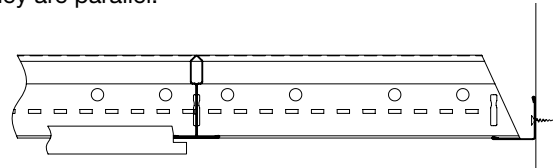

5.2.1 Kerfs Perpendicular to the Wall

Measure the size of the opening from the edge of the T-Bar to the edge of the molding and add 3/8". Measure and mark the face side of the panel at both edges.

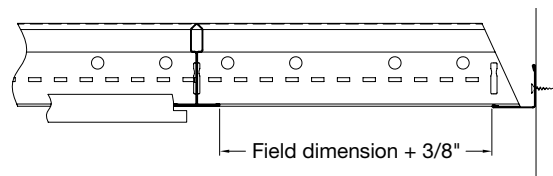

5.2.2 Cutting the Panel

WoodWorks® Channeled Vector panels should not be cut for borders. WoodWorks Vector panels should be used at borders to adequately support the ceiling installation. Cut the panel using standard woodworking tools and, where possible, a straight edge.

A table saw is recommended for straight cuts and a band saw for curved cuts. In general, these practices will be typical of those employed in finish carpentry.

▲ CAUTION! WOOD DUST. Sawing, sanding, and machining wood products can produce dust. Airborne wood dust can cause respiratory, eye, and skin irritation. The International Agency for Research on Cancer (IARC) has classified wood dust as a nasal carcinogen in humans.

Precautionary measures: If power tools are used, they should be equipped with a dust collector. If high dust levels are encountered, use an appropriate NIOSH-designed dust mask. Avoid dust contact with eyes and skin.

First Aid Measure in case of irritation:

Flush eyes or skin with water for at least 15 minutes.

5.2.3 Installing the Border Panel

Install these borders just like full-size panels. Place the cut edge toward the wall and engage the "A" edge on the suspension system flange, rotate the "B" edge up into the suspension system opening, and draw it back into place.

5.2.4 Kerfs Parallel to the Wall

Measure the panel as described in section A. Mark and cut the panel so as to retain the "A" edge.

5.2.5 Attach Border Clips

Apply two WoodWorks® Vector® border clips (provided in the carton) to the cut edge of the panel as shown. Use one #8 x 9/16" screw in each clip.

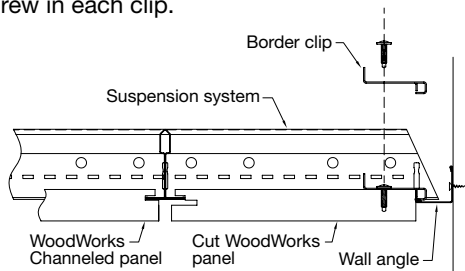

5.2.6 Installing the Panel

Engage the kerfed edge of the panel on the suspension system flange parallel to the wall. Rotate the cut edge up into the suspension system opening and draw the panel toward the wall until the border clips rest on the molding and the "A" edge drops into place.

5.2.7 Corner Panel Installation

Preparation of the corner panel will require the removal of two edges. Mark and cut the panel to retain a portion of the "A" edge. Support the opposite side of the panel by installing two WoodWorks Vector Border clips as shown above.

5.2.8 Treating Exposed Edges

Cut panel edges that are exposed to view will have to be treated to look like factory edges. Prefinished peel and stick edge banding is recommended for this purpose. Cut edge must be clean and smooth before applying edge banding. Peel

off the release paper and apply the edge banding using finger pressure or a small trim roller. Trim excess material with a sharp knife blade or a chisel.

5.3 Ordering Edge Banding Material

Prefinished pressure sensitive adhesive banding is available 15/16" wide and in 50' lengths. Standard colors include Cherry, Maple, and Anigre (Steamed Beech). Many other standard veneer choices are also available. Several vendors can provide prefinished banding. The brand of banding used is of no consequence as long as the finish is an acceptable match to the face veneer. One such vendor is:

Fastcap (Fastedge products)

3725 Irongate Road, Suite 105

Bellingham, WA 98226

Customer Service Phone: (888) 443-3748

Web: www.fastcap.com for distributor locations

6. ODD SIZE PANELS

6.1 General

Special size panels are available to accommodate less than full modules within the field of the ceiling.

6.2 Measuring the Panel

Measure, mark, and cut the panel 1/4" smaller than the "nominal" dimension required. For example, if the panel is to fit into a nominal 18" x 24" opening, it would be cut 17-3/4" wide.



6.3 Recut the Edge Detail

Turn the panel over and recut the reverse Tegular edge as dimensioned in the drawing below. Protect the face of the panel from damage.

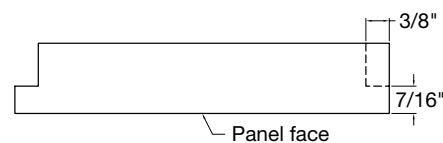

6.4 Treat the Cut Edge

Treat the remanufactured edge as described in section 5.2.8. Install like a full-size panel.

7. FIXTURE TRIM

7.1 General

The design of the edge details used on Vector creates a gap between the face of the suspension system and the edge of the panel. This gap is necessary to allow the panel to lift sufficiently to allow installation and removal. This gap may be objectionable when type G light fixtures and air diffusers are used. For this reason, fixture trim kits are available for use with Vector panels.

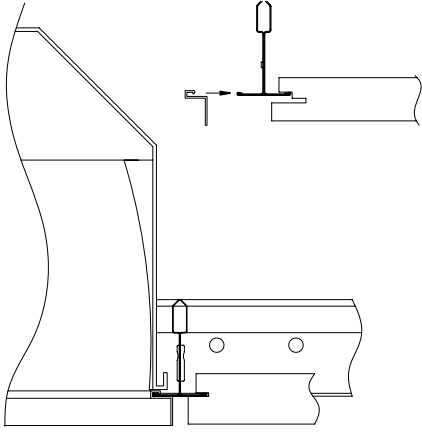

7.2 Trim Installation

Fixture trims are provided in pre-mitered lengths of plastic molding that snap onto the exposed flanges of the suspension system at the location of lay-in light fixtures or other accessories that sit into the suspension system in place of a ceiling panel. Trim elements may be installed before or after the placement of the ceiling panels.

Woodworks® Channeled Vector® Clip Arrangement

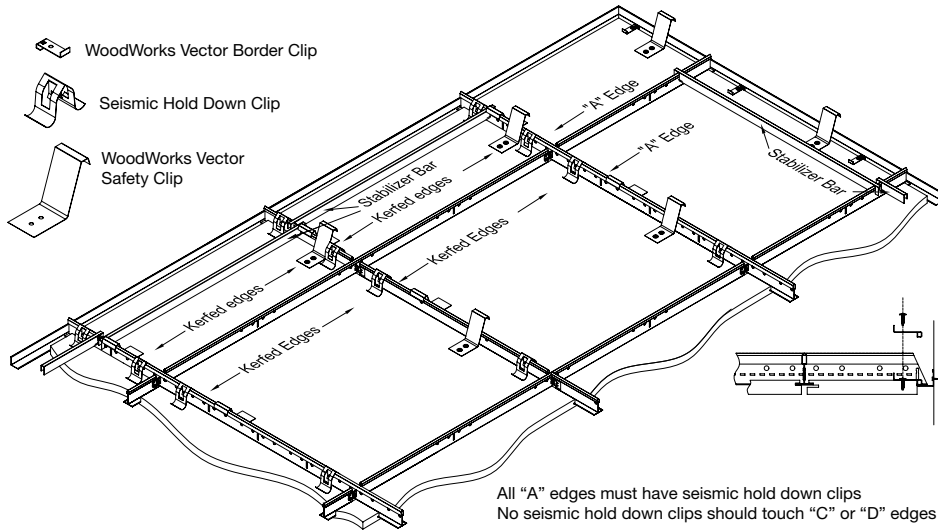

Figure 1

MORE INFORMATION

For more information, or for an Armstrong representative, call 1 877 ARMSTRONG.

For complete technical information, detail drawings, CAD design assistance, installation information, and many other technical services, call TechLine™ at 1 877 ARMSTRONG or FAX 1 800 572 TECH.

For the latest product selection and specification data, visit armstrong.com/woodworks. U.S. Patents Pending, including US Publication No. 2004/0182022.

All trademarks used herein are the property of AWI Licensing Company and/or its affiliates © 2014 AWI Licensing Company • Printed in the United States of America

BPLA-297691-1214



CEILING & WALL SYSTEMS