

WoodWorks® Grille – Tegular & WoodWorks® Linear Tegular

Integrated Light Connection Clip Assembly and Installation Instructions

This installation guide is a supplement to the standard WoodWorks® Grille Tegular and WoodWorks® Linear Tegular installation instructions.

1. SOLUTION OVERVIEW

Integrated Light Connection Clips enable installation of Backlight® srl CHIARO light fixture and XAL® PANO Low-Profile Linear Plank light fixture with the specified panel – eliminating the need for modification of the grid system and independent suspension of the light fixture. System ensures the Sliding Integration Bracket is housed in the lighting track, while the Integrated Light Connection Clip slides into and is secured in the Sliding Integration Bracket. The Integrated Light Connection Clip is attached to the Armstrong® Ceiling Heavy Duty Prelude® XL® or Suprafine® XL Suspension System. Continuous and discontinuous lighting layouts are possible with this system.

NOTE: Linear light fixtures and Sliding Integration Bracket are sold by Backlight srl and XAL.

These instructions represent the specific WoodWorks Grille Tegular and WoodWorks Linear Tegular panels that are referenced in the chart on the last page. No other WoodWorks Grille Tegular and WoodWorks Linear Tegular panel type should be field modified for use with the Integrated Light Connection Clip.

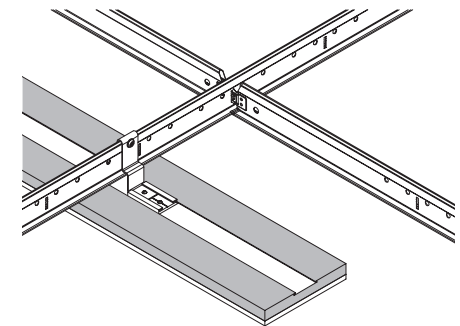
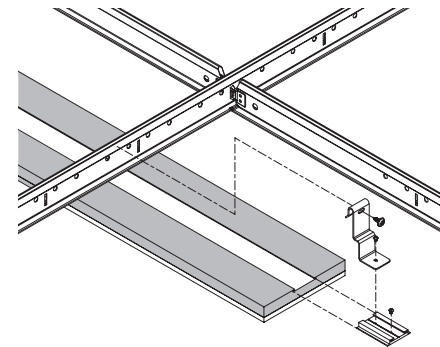
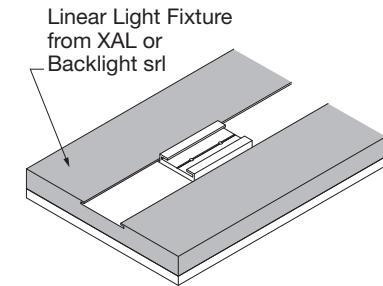
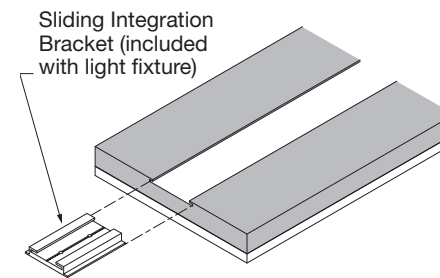

Installation of this ceiling and integrated lighting solution will require coordination between the ceiling contractor and the electrical contractor.

The following installation instructions recommend installation by different trades for the purpose of assigning responsibilities during installation. However, role clarification can be determined on a job-per-job basis. General Contractor should work with electrical contractor and ceiling contractor to clearly assign responsibilities.

As with all integrated construction solutions, coordination and collaboration between trades is critical for a successful and efficient installation.

2. DESIGN CONSIDERATIONS

2.1 Lights

- Lights must be supported by attachment to the grid at no more than 2' O.C.
- Lights must be supported within 1' of each end (max cantilever of 12" from nearest support)
- Length of lights are designed to coordinate with the length of panels
- Lights must be installed parallel with linear visual of panels
- Only one light may be installed in a modified panel
- Lights must be installed within field of install and not integrated into cut perimeter panels
- 24" x 24" WoodWorks® Grille Tegular panels (Item 6723F51L2T9_ _ _) are designed for basketweave installation
- Based on the number of slats removed for the width of the light fixture, only 3-1/4" width fixtures can be centered within a panel. 2" and 5-1/4" width lights require an odd number of slats to be removed.

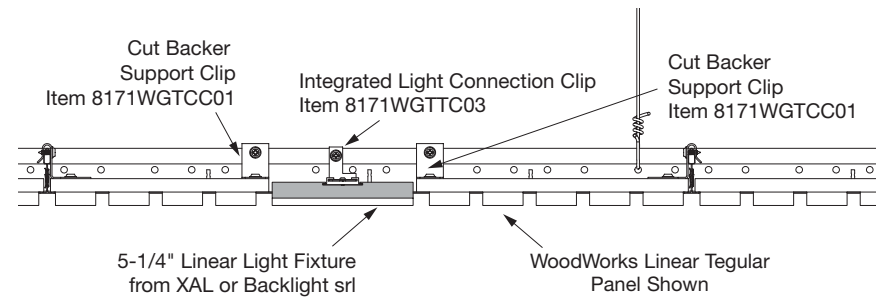

Side View

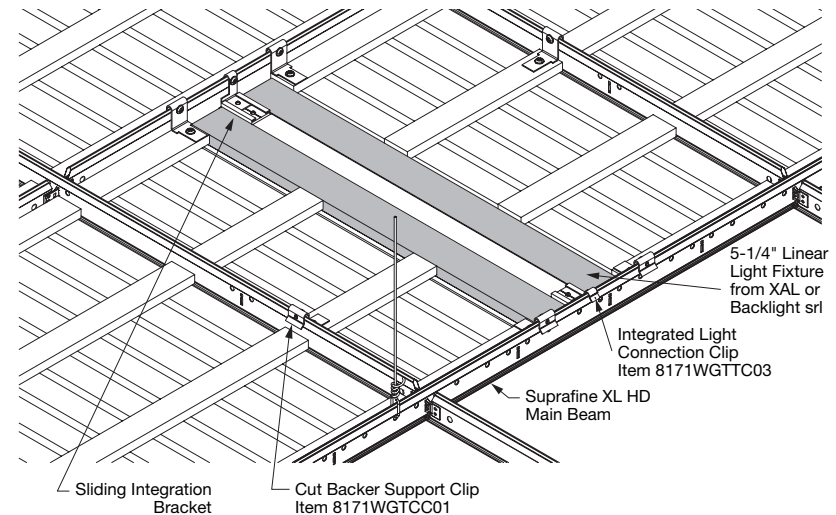

24" x 24" Panel with 23-3/8" Linear Light Fixture

2.2 WoodWorks® Grille Tegular and WoodWorks® Linear Tegular Panels

- 2", 3-1/4", or 5-1/4" lights may be used with WoodWorks® Grille Tegular and WoodWorks® Linear Tegular
- Reveal between light and slats will coordinate with the reveal from slat to slat
- Modified panels are required to be secured in the grid system with Cut Backer Support Clips (Item 8171WGTCC01)
- Coordination between ceiling contractor and electrician is required for installation
- When modifying the panels, the entire slat must be removed

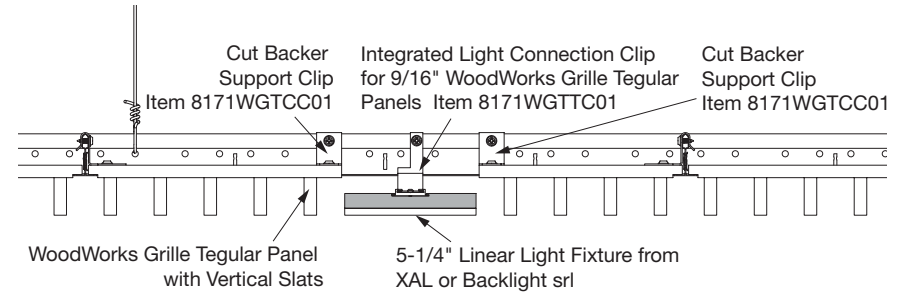

Side View

2.3 Suspension System

The suspension system does not require modification and must be installed following the standard WoodWorks Grille Tegular and WoodWorks Linear Tegular instructions.

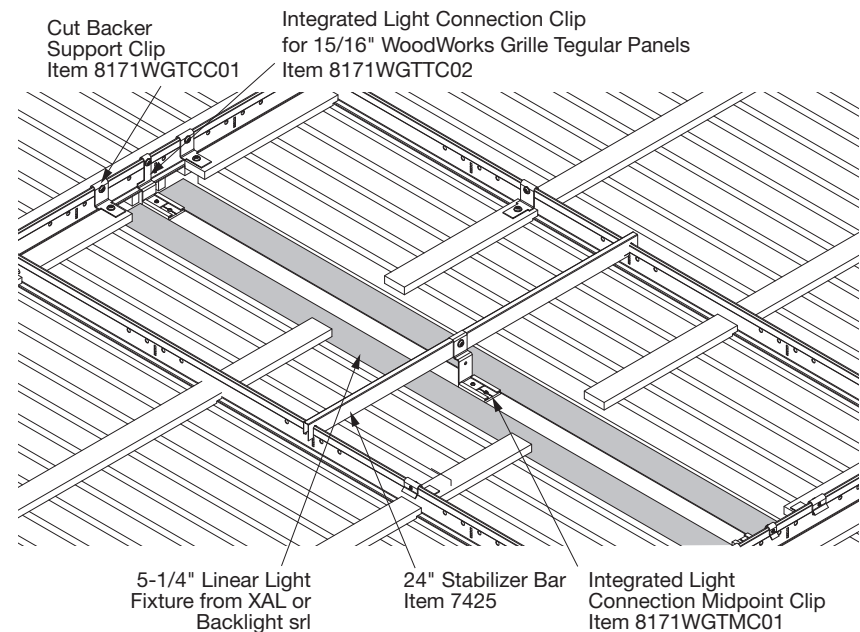

24" x 48" Panel with 47" Linear Light Fixture

3. SYSTEM MODIFICATIONS

The following installation method uses WoodWorks® Grille Tegular and WoodWorks® Linear Tegular panels. Refer to section 5 for additional steps required for seismic design category D, E, and F installations.

3.1 Standard Panel Modification – Cut Panel to Remove Slats/Backers

Panels must be cut and modified to install lights within the panel module (*Fig 1*). The slats and backers are both removed by this cut (or cuts) where the light will be replacing that panel portion. If a middle slat(s) is removed you will be left with two panel portions and a scrap portion. If an end-slat(s) is removed you will be left with one panel portion and a scrap portion. The width of the backer of the panel portion that has been removed should be equal to the width of the light to ensure the light has enough room to install in the modified space. Remaining panel portions for installation will have Cut Backer Support Clips attached to the backers to secure the panel portions in place within the grid. These clips should be attached with screws no smaller than #7 in diameter and no longer than 1/2" to avoid piercing the face of the backer.

Pre-drilling is recommended to avoid splitting the backers. Remaining panel portions must have two slats at a minimum.

3.2 Integrated Light Connection Clip Spacing

- **15/16" Grid System:** Integrated Light Connection Clips should be spaced so that the center of the feature that hooks over the grid is positioned 1/2" past the end of the fixture. The 47" long lights require a Integrated Light Connection Midpoint Clip (Item 8171WGTMC01) to be attached to a Stabilizer Bar (Item 7425) to ensure the light remains flush with the panels. See (*Fig 2, 3*) referencing the general locations of the Sliding Integration Brackets for each light. There are two Sliding Integration Brackets per 23" light and three per 47" light.

- **9/16" Grid System:** Integrated Light Connection Clips should be spaced so that the center of the feature that hooks over the grid is positioned 5/16" past the end of the fixture. The 47" long lights require a Integrated Light Connection Midpoint Clip (Item 8171WGTMC01) to be attached to a Stabilizer Bar (Item 7425) to ensure the light remains flush with the panels. See (*Fig 4, 5*) referencing the general locations of the Sliding Integration Brackets for each light. There are two Sliding Integration Brackets per 23-3/8" light and three per 47" light.

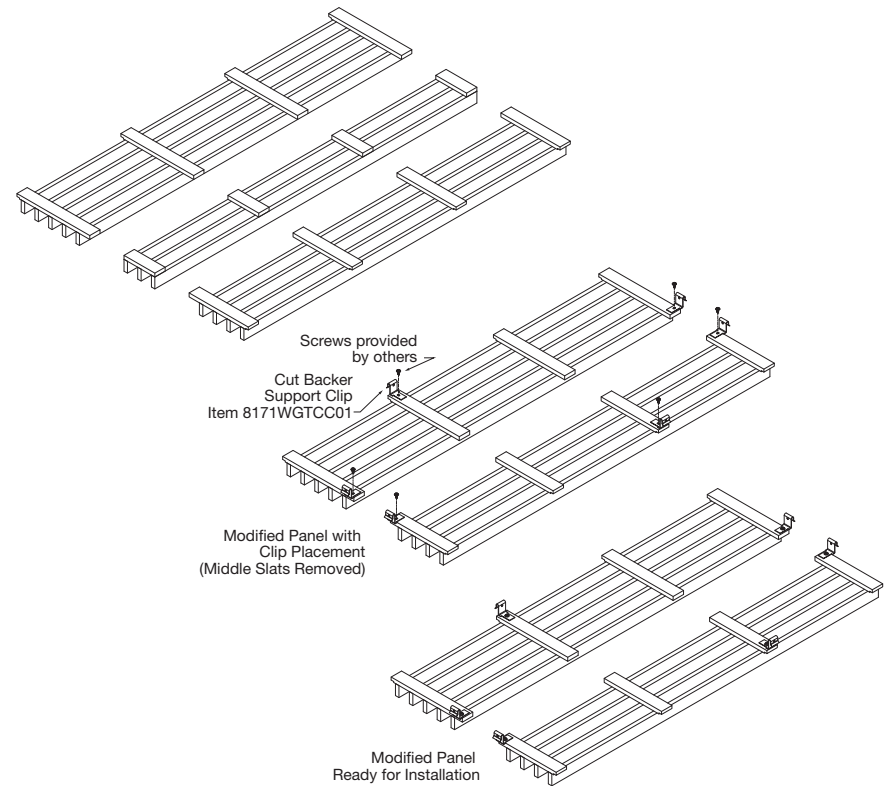

(Fig 1)

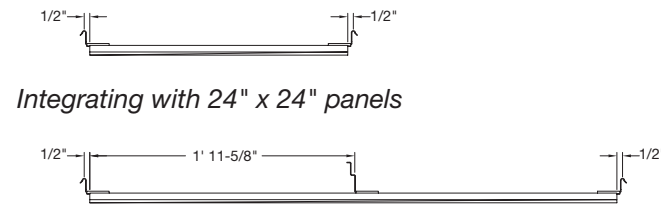

Integrating with 24" x 24" panels

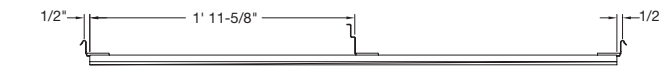

Integrating with 24" x 48" panels

(Fig 2, 3)



Integrating with 24" x 24" panels

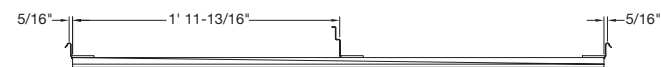

Integrating with 24" x 48" panels

(Fig 4, 5)

4. INSTALLATION OF THE ASSEMBLY

Place the remaining panel portions, modified with Cut Backer Support Clip and the light, into the grid opening at their specified locations. Secure any Cut Backer Support Clips to grid members with fasteners in a D, E, or F seismic area. The compatible lighting fixture and driver should be installed by a qualified electrician in accordance with the light manufacturer's instructions.

NOTE: 47-3/8" and 47" lights used with products 6733F51L4T9___, 6733F51L4T5___, and 6723F51L4T5___ require additional support to prevent sag. The 24" Stabilizer Bar (Item 7425) will need to be added across the grid members, and the Integrated Light Connection Midpoint Clip (Item 8171WGTMC01) will need to be attached to the WoodWorks® Grille Tegular and WoodWorks® Linear Tegular panel and screwed into the Stabilizer Bar (Item 7425).

5. SEISMIC

This system has been engineered for application in seismic areas based on the instructions listed in this document and has been successfully tested in applications simulating seismic design categories D, E, and F. Refer to the seismic section in the standard WoodWorks Grille Tegular and WoodWorks Linear Tegular instructions for all requirements related to seismic performance for this product.

All Integrated Light Connection Clips must be screw attached to the bulb of the grid system with metal framing screws (minimum of #8 x 1/2") provided by the contractor.





All modified panels must be secured to the suspension system by inserting a metal framing screw (minimum of #8 x 1/2") through the Cut Backer Support Clip and bulb of the grid.

Certain jurisdictions may have additional requirements for lighting systems. Consult your local authority having jurisdiction for specific requirements. Consult your local authority having jurisdiction for specific requirements.

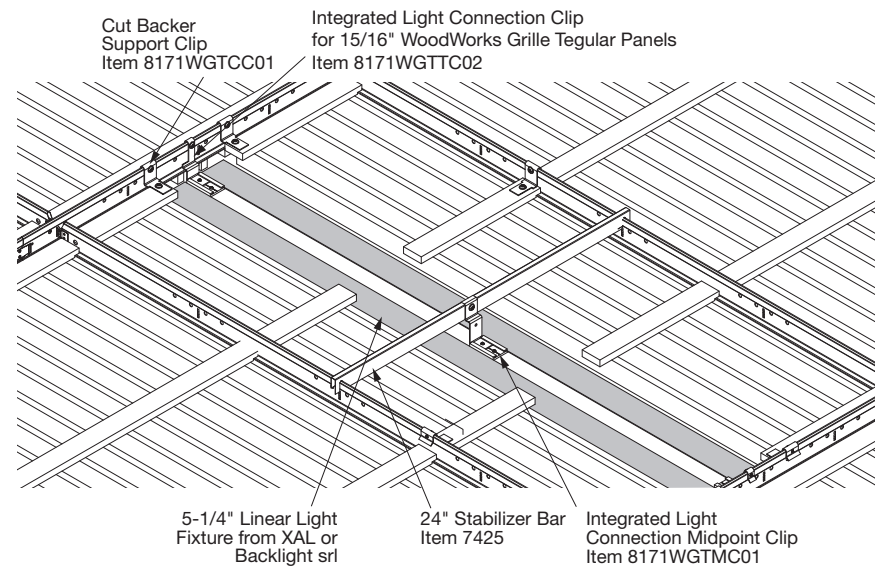
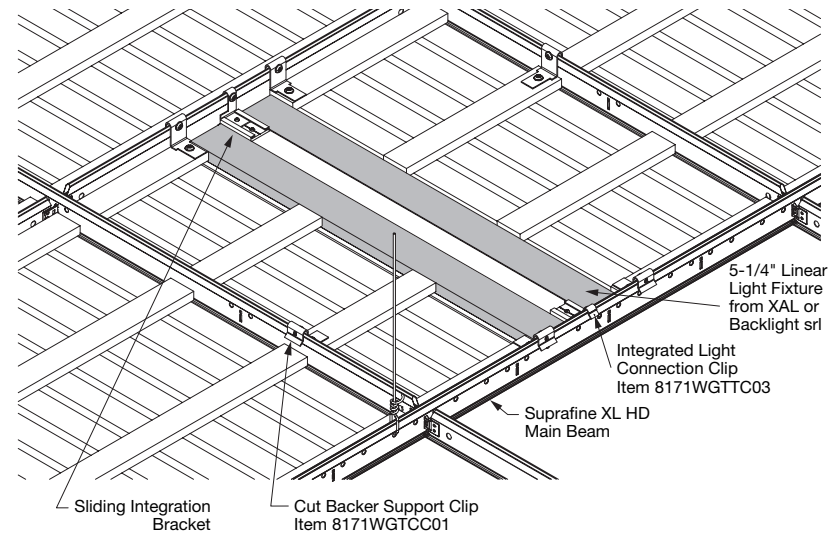
6. LIGHTING FIXTURES

Compatible with Backlight® srl CHIARO light fixture and XAL® PANO Low-Profile Linear Plank light fixture. For detailed lighting information, contact your local Backlight srl or XAL representative.



Clip Item No.	Description	Coordinating WoodWorks® Panel Item No.	Panel Field Modification Required*	Compatible Partner Light Fixture Dimensions W x L (Inches)	Clips Required per Light Fixture	
WoodWorks® Grille Tegular and WoodWorks® Linear Tegular						
 8171WGTC01	Integrated Light Connection Clip for 9/16" WoodWorks Grille Tegular	6723F51L2T9_ _ _	Remove 1 slat	2" x 23-3/8"	2	
				Remove 2 slats	3-1/4" x 23-3/8"	2
				Remove 3 slats	5-1/4" x 23-3/8"	2
 8171WGTC02	Integrated Light Connection Clip for 15/16" WoodWorks Grille Tegular	6723F51L4T5_ _ _	Remove 1 slat	2" x 47"	2	
				Remove 2 slats	3-1/4" x 47"	2
			Remove 3 slats	5-1/4" x 47"	2	
 8171WGTC03	Integrated Light Connection Clip for WoodWorks Linear Tegular	6733F51L2T9_ _ _	Remove 2 slats	3-1/4" x 23-3/8"	2	
				Remove 3 slats	5-1/4" x 23-3/8"	2
		6733F51L4T9_ _ _	Remove 2 slats	3-1/4" x 47-3/8"	2	
			Remove 3 slats	This item is for 9/16" grid 5-1/4" x 47-3/8"	This item is for 9/16" grid	2
		6733F51L2T5_ _ _	Remove 1 slat	2" x 23"	2	
			Remove 2 slats	3-1/4" x 23"	2	
			Remove 3 slats	5-1/4" x 23"	2	
		6733F51L4T5_ _ _	Remove 1 slat	2" x 47"	2	
			Remove 2 slats	3-1/4" x 47"	2	
			Remove 3 slats	5-1/4" x 47"	2	
 8171WGTC01	Integrated Light Connection Midpoint Clip for 24" x 48" panels (installed with item 7425, 24" Stabilizer Bar)	6723F51L4T5_ _ _	—	—	1	
		6733F51L4T9_ _ _	—	—	1	
		6733F51L4T5_ _ _	—	—	1	
 8171WGTC01	Cut Backer Support Clip	6723F51L2T9_ _ _	—	—	6	
		6723F51L4T5_ _ _	—	—	6	
		6733F51L2T9_ _ _	—	—	6	
		6733F51L4T9_ _ _	—	—	6	
		6733F51L2T5_ _ _	—	—	6	
		6733F51L4T5_ _ _	—	—	6	

*Made-to-order panels that eliminate the need for field modification of standard panels are available via ASQuote@armstrongceilings.com

MORE INFORMATION

For more information, or for an Armstrong Ceilings representative, call 1 877 276 7876.

For complete technical information, detail drawings, CAD design assistance, installation information, and many other technical services, call TechLine customer support at 1 877 276 7876 or FAX 1 800 572 TECH.

XAL® is a registered trademark of XAL Inc.; Backlight® srl is a registered trademark of BACKLIGHT srl;

All other trademarks used herein are the property of AWI Licensing LLC and/or its affiliates.

© 2023 AWI Licensing Company Printed in the United States of America

