

WOODWORKS® Linear – Solid Panels

Interior Installation Instructions

1. GENERAL

1.1 Product Description

WoodWorks® Linear Solid Wood panels are constructed of solid poplar wood. Panel dimensions are 12 x 95 x 3/4" and install on a 96" module (with a 1/2" backer, total panel thickness is 1-1/4"). Panels are available in two plank widths and a variety of finishes. Panels use the Prelude® XL® 15/16" suspension system. Custom finishes and plank widths are offered through the Architectural Specialties department. Black fleece or black acoustic infills can be specified for use with the panels to minimize the view of the plenum and provide acoustical performance (*Fig 1*).

1.2 Material and Surface Finish

Planks and backers are solid poplar (yellow or hybrid) wood. Backers have a black factory finish.

1.3 Storage and Handling Prior to Installation

All ceiling components should be stored in a dry interior location and must remain in the original packaging prior to installation to avoid damage. The materials must be stored off the floor in a flat, level condition. Do not store in unconditioned spaces with humidity greater than 55% RH or lower than 25% RH, or with temperatures above 86°F or lower than 50°F. Use proper care when handling to avoid damage or soiling.

CAUTION: Use proper care and caution when handling suspension systems due to the sharp edges on all exposed clips.

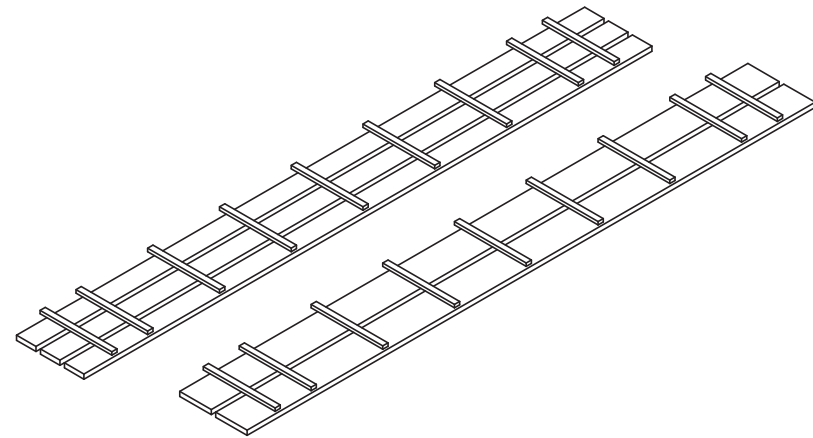

(Fig 1)

1.4 Site Conditions for Installation

Building areas that will receive a ceiling must be free of construction dust and debris. Installation of the products must be carried out where the temperature is between 50°F and 86°F and relative humidity levels maintained between 25% RH and 55% RH. These temperature and humidity conditions must be met throughout the lifetime of the ceiling.

Real wood products are natural building materials and they will react to changes in humidity. (Wood tends to contract with lower humidity and expand with higher humidity.)

Wood may also have a tendency to warp, twist, or bow due to the natural stresses in the components and these humidity changes. Be aware of these natural tendencies when evaluating the products.

It is also necessary for the area to be enclosed and for the HVAC systems to be functioning and in continuous operation. All wet work (plastering, concrete, etc.) must be complete and dry. These products cannot be used in exterior applications.

To ensure that the ceiling panels have stabilized to the current building conditions, prior to their installation, the planks must be placed in an environmentally stable building location for a minimum of 72 hours.

1.5 Warranty

The WoodWorks® Linear Solid Wood panels have been tested based on the installation method described in this document. The warranty will be voided if you do not follow these instructions.

1.6 Color

WoodWorks Linear Solid Wood panels are made of solid wood and are available in 15 standard finishes. Custom options are available. Beautiful natural variations in color and grain are characteristic of solid wood products. Knots of up to 1/2" in diameter can be expected in this product. To maximize visual consistency, panels should be unpacked and examined collectively to determine the most desirable arrangement for installation.

1.7 Ordering Considerations

Be sure to account for extra material that is normally needed for wood installations. When installing WoodWorks Linear Solid Wood panels, you should consider ordering at least 5% extra material.

Up to 10% more may be needed for odd size or diagonal installations. It is the customer's responsibility to plan each layout and order the correct amount of installation material needed, taking into account the design.

1.8 Fire Performance

As with other architectural features located at the ceiling, WoodWorks Linear Solid Wood panels may obstruct or skew the planned fire sprinkler water distribution pattern, or possibly delay or accelerate the activation of the sprinkler or fire detection systems by channeling heat from a fire either toward or away from the device. Designers and installers are advised to consult a fire protection engineer, NFPA 13, and their local codes for guidance where automatic fire detection and suppression systems are present.

1.9 Cleaning Recommendations

WoodWorks Linear Solid Wood panels can be cleaned with a soft, dry cloth.

2. DESIGN AND INSTALLATION CONSIDERATIONS

2.1 Directionality

WoodWorks® Linear Solid Wood panels have a female and male side. Installation should be started with the male side closest to the wall (*Fig 2*).

Grain direction runs parallel with the length of the panels. The length of the panels must be installed perpendicular to the main beams (see ceiling layout and section details on page 13 of this document).

2.2 Sprinklers

Linear wood, as with other architectural features located at the ceiling, may obstruct or skew the planned fire sprinkler water distribution pattern, or possibly delay or accelerate the activation of the sprinkler or fire detection systems by channeling heat from a fire either toward or away from the device. Designers and installers are advised to consult a fire protection engineer, NFPA 13, and local codes for guidance where automatic fire detection and suppression systems are present.

2.3 Plenum

Panels are screw-attached to the face of the suspension system, and do not need to travel above the suspension system during installation.

2.4 Approximate System Weight (lbs/SF) and Attachment to Deck

Panels weigh approximately 1.88 lbs/SF. Fasteners for suspending grid from structure should be specified by contractor to hold system weight plus safety factor required by local code.

The weight of the suspension system ranges between 0.2-0.3 lbs/SF based on grid layout and components used.

2.5 Accessibility

Panels installed with screws to the suspension system are accessible but are not intended for repeated access. Panels can be unscrewed and re-attached to allow access. For increased accessibility, 3" slat panels can be installed with backer clips. See Section 3.1.

For areas that require repeated accessibility, an access panel can be field-fabricated. Contact TechLine for details.

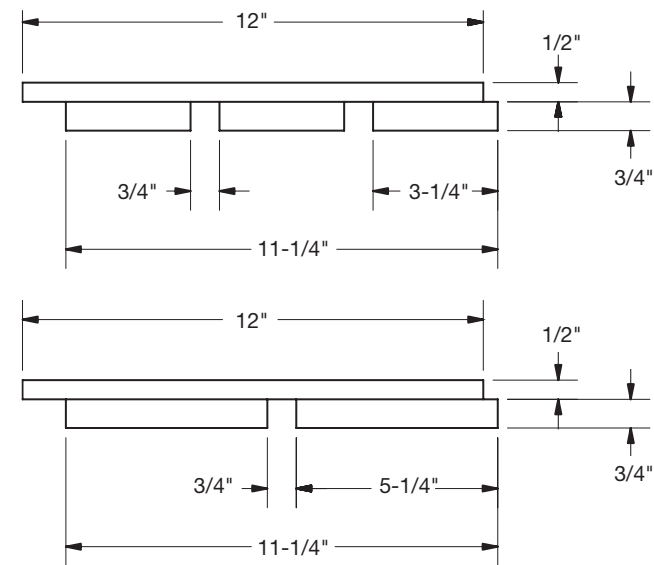

(Fig 2)

3. ACCESSORIES

3.1 Backer Clips

Metal spring clips attach panels to 15/16" Prelude® grid. Based on clip spacing requirements (Section 7.2), backer clips are only compatible with the 3" slat panels, Item 8176.

3.2 Trim Accessories

Wood trim is available in coordinating finishes. Trims come in 96" lengths with clip, Use Item 5925 to fasten trim to the grid (*Fig 3*):

- 7146H4L96_ _ _: 4" Solid Wood Trim
- 7146H6L96_ _ _: 6" Solid Wood Trim

3.3 BioAcoustic™ Infill panel

An 11 x 48 x 1" black BioAcoustic infill panel (Item 6657) can be installed to improve acoustical performance. Refer to the Acoustical Infill Panels installation guide for details.

3.4 Flat Backer Kit: Item 7290GBL

Replacement backers for field-cut panels.

3.5 Finish Stain for Cut Ends

- 5457GAL1_ _ _: Gallon size stain to finish cut ends of solid wood panels
- 5457QT1_ _ _: Quart size stain to finish cut ends of solid wood panels

3.6 Acoustic Fleece

WoodWorks® Linear Solid Wood panels do not come with acoustic fleece as standard. Contact ASQuote for factory-applied black fleece backer.

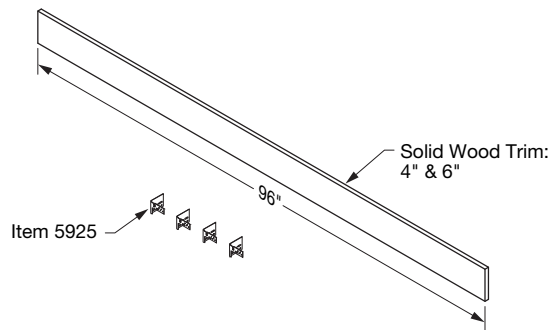

(Fig 3)

4. SUSPENSION SYSTEM

The requirements listed here represent the manufacturer's minimum acceptable installation recommendations, and may be subject to additional requirements established by the local authority having jurisdiction.

- All installations should follow ASTM C636
- All references to suspension component duty ratings are per ASTM C635 and E3090

4.1 System Components

The suspension system must be standard heavy-duty 15/16" Prelude grid.

- Cross tees must have XL® end details, be 1-11/16" tall, and heavy-duty equivalent (16 lbs/LF)
- Acceptable cross tees are listed on the panel property table found on the last page
- Use black 360° painted suspension system for the best overall visual in installations where the suspension system may be visible or in line of sight

4.2 Suspension Rules (Wall to Wall)

- Main beams must be installed within 36" of the perimeter and then at 48" O.C. (On Center)
- Hanger wires must be installed within 24" of the perimeter and then no more than 48" O.C.
- The ARBRKT or Rigid Attachment Clip (Item 6459BL, available in black) can be substituted for hanger wires in uptight-to-deck installations and must follow the same rules for spacing

4.3 Layout

Due to the weight of the panels (1.88 lbs/SF), WoodWorks® Linear Solid Wood panels can be installed on a 24" x 48" "H" or "cross-hatched" layout. Main beams are installed at 48" O.C., with 4' cross tees installed perpendicular to the main beams every 48" O.C. 4' cross tees are then installed parallel to the mains at the midpoints of the perpendicular 4' cross tees (Fig 4).

- Main beams must run perpendicular to the panel length
- The suspension system must be leveled to within 1/4" over 120" and must be square to within 1/8" in a 48" x 48" module. Installation on suspension systems that do not meet this tolerance will produce unacceptable panel alignment.

See page 13 of this document for a grid and panel layout example.

4.4 Installation Steps

1. Refer to the reflected ceiling plan for the finished height of the ceiling. Add the overall height of the WoodWorks Linear Solid Wood panel to determine the elevation of the suspension system. The face of the linear panels drops 1-1/4" below the face of the grid.
2. Install wall molding along the perimeter at the established suspension system elevation.
3. Refer to the reflected ceiling plan to determine the panel orientation and border panel sizes. Main beams are installed perpendicular to the panel length.
4. Install grid components per the layout in Section 4.3. This layout is required to keep the WoodWorks Linear Solid Wood panels perpendicular to the main beams and backers aligned along the suspension system for screw and clip attachment.

4.5 Additional cross tees can be installed in the system, as needed, to frame out mechanical fixtures such as lights and speakers. If 2' cross tees are required, they must meet the cross tee requirements in Section 4.1.

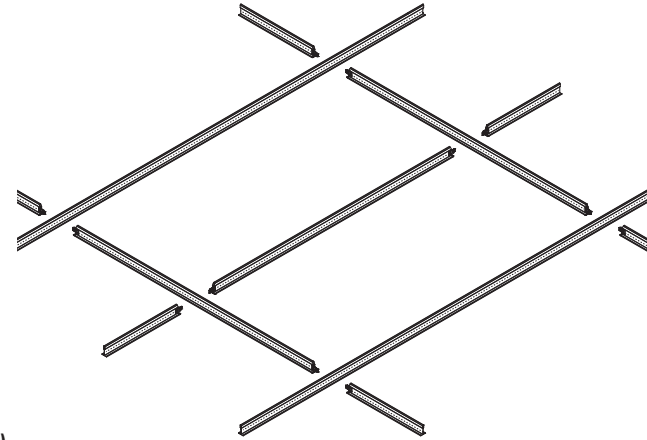

(Fig 4)

5. FLOATING PERIMETER / TRIM FOR DISCONTINUOUS INSTALLS

5.1 Solid Wood Perimeter Trim

Perimeter trim should be installed using a mechanical fastener to secure the Item 5925 clip to the suspension system and the trim. The trim must be supported by having hanger wires within 8" of the trim along the grid at 48" O.C. along the length of the trim.

4" and 6" solid wood trims are available in coordinating finishes. These trim pieces are to be used in clouds with straight perimeter borders only. Refer to Section 5.2 for curved conditions. Use a #20 biscuit and wood glue to join two pieces of trim together on a straight run or at a mitered corner. Use one biscuit for 4" and two biscuits for 6" trim. A finishing pin nail can be used to hold your mitered corners together while the biscuit joint dries. The clip (Item 5925 included with trim) is fastened to the trim and suspension system using #8 x 1/2" pointed truss head screw. The clip (Item 5925) can also be used to attach straight pieces together at the joint once the biscuit and glue have been applied **(Fig 5 & Fig 6)**.

WoodWorks® Linear Solid Wood panels drop 1-1/4" below the face of the grid.

5.2 Axiom® Perimeter Trim

Axiom® Vector inverted trim can be used for straight or curved cloud installations with WoodWorks Linear Solid Wood panels. The use of the adjustable trim clip, Item 7239, will fasten the trim to the suspension system and allow for trim height adjustments as needed **(Fig 7)**.

6. TRANSITIONS

Any transitions between WoodWorks Linear Solid Wood panels and other products/ceiling will have to account for the 1-1/4" panel drop below the face of the grid.

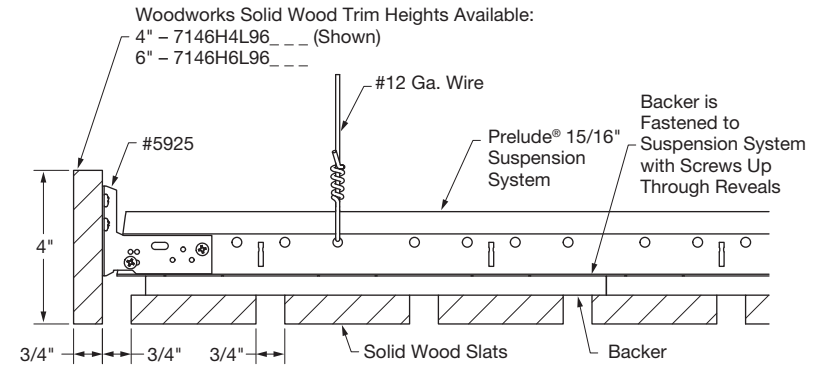

(Fig 5)

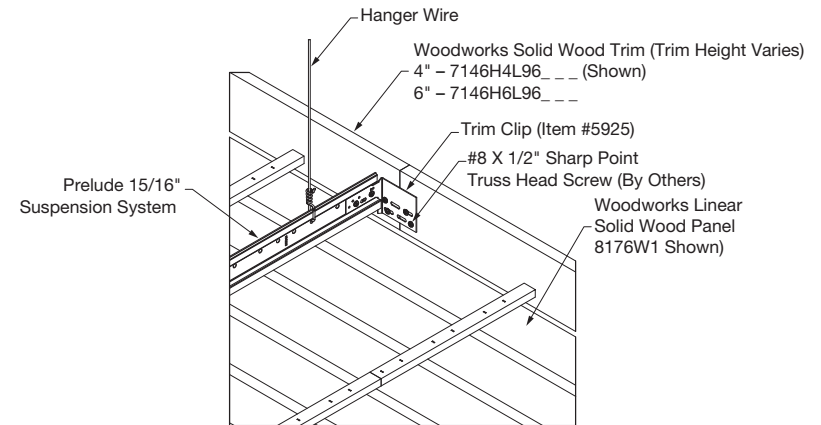

(Fig 6)

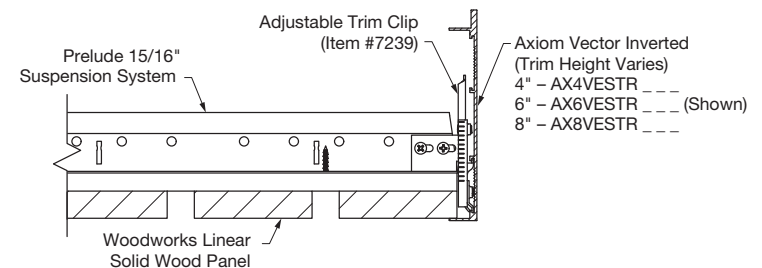

(Fig 7)

7. PANEL INSTALLATION

7.1 Edge Detail/Interface

- Panel dimensions are 12 x 95 x 3/4" (with a 1/2" backer, total panel thickness is 1-1/4")
- WoodWorks® Linear Solid Wood panels have a female and male side. Installation should be started with the male side closest to the wall. Backer may need to be trimmed for proper panel alignment (*Fig 8 & Fig 9*).

7.2 Attachment Methods

7.2.1 Screw Attachment

WoodWorks Linear Solid Wood panels can be attached to the grid with screws. The screws must be equivalent to #6 x 1-1/4" bugle head Hi-Lo screws. Four of the backers will align with the grid system. It is recommended that pilot holes are drilled into these backers before screw attachment. Use two screws in each backer that aligns with the grid system, totaling eight screws per full-size panel (*Fig 10 & Fig 11*). Caution is necessary when screwing panels to the suspension system; over insertion of fasteners could cause backers to splinter.

7.2.2 Backer Clip Installation

Backer Clips (Item 5687) are an optional method for panel attachment to grid. These clips can only be used with panels that have the nominal 3" planks to ensure proper clip placement. Insert two clips between the planks on each backer that aligns with the grid, totaling eight backer clips per full-size panel.

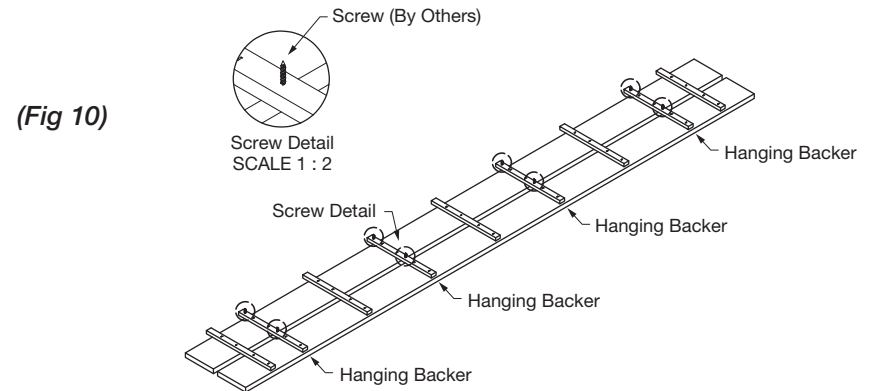
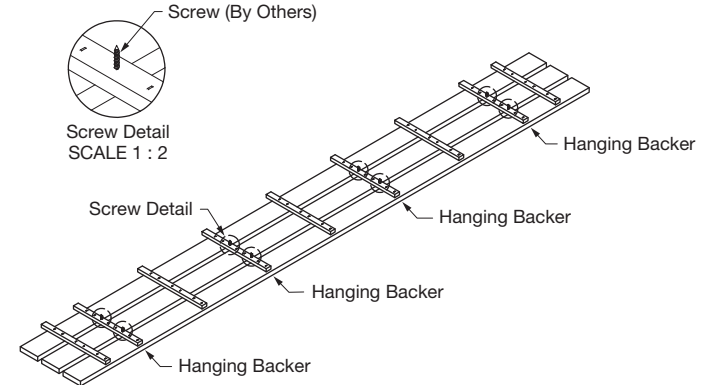
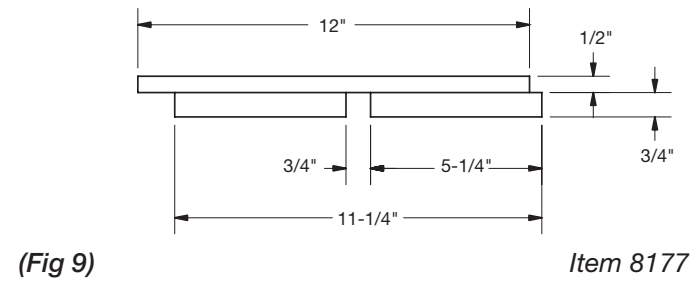
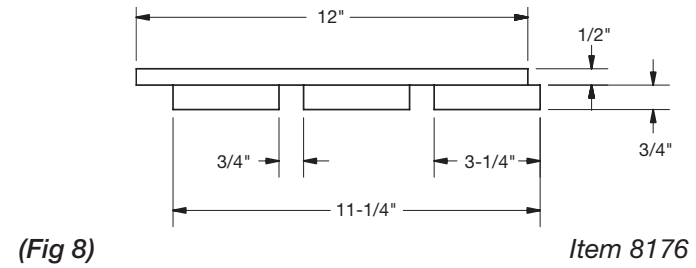

(Fig 11)

Push upwards on the clip to engage the clip tabs onto the suspension system flange. Make sure both clip tabs engage the suspension system flange (*Fig 12*).

7.3 Panel Installation

WoodWorks® Linear Solid Wood panels are installed in sequence across the space. The first row of panels will have the male side toward the wall. The backers may need to be trimmed for proper panel alignment.

Begin at one wall, raise the panel up against the suspension system and align the backers with it.

Attach the panels to the grid using either of the attachment methods in Section 7.2.

Continue installing WoodWorks Linear Solid Wood panels — male to female — across the room.

7.4 End-to-End Panel Reveal

WoodWorks Linear Solid Wood panels will have a 1" reveal between panel ends. This uniform spacing and alignment is maintained by the 15/16" suspension system (*Fig 13*).

7.5 Border Panels

Refer to the ceiling plan for border panel size and spacing.

Panels require support within 12" of the panel end. When panels are cut to length, additional cross tees may need to be installed for backer attachment with screws or backer clips. This means that wherever a panel is cut, the backer closest to the end of the panel must be attached to grid. If new backers are needed, Item 7290GBL can be purchased separately to be field-applied using 1/2" wide flat crown staples with 3/4" legs.

For panels that are screw-attached to the grid, no additional steps are required to secure border panels.

When using backer clips, the border panels must be secured at the specified dimension by using a mechanical fastener to secure the panel to the suspension system. This can be a direct screw attachment as described in Section 7.2.1.

7.6 Cutting Panels

When you cut a panel to length, you can use normal woodworking tools (e.g., circular saws, saber saws, coping saws, etc.). Cut through the face of the panels to the back to avoid visible rough edges.

Penetrations for sprinklers (or other fixtures) can be accomplished by simple interruption of the wood planks at those locations or by using normal woodworking tools to cut access in the planks.

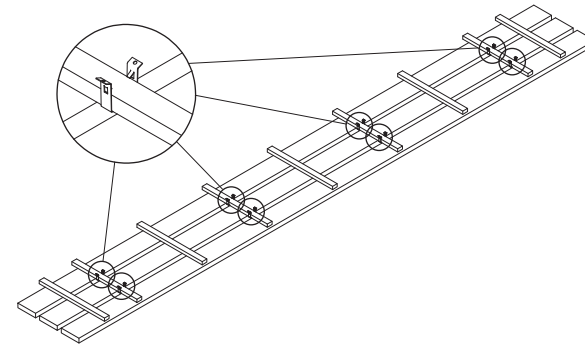

(Fig 12)

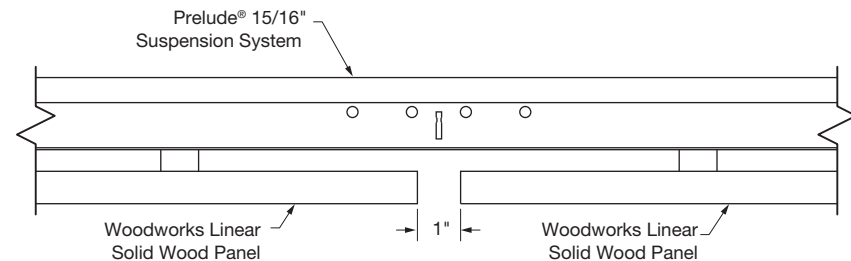

(Fig 13)

▲ CAUTION! WOOD DUST. Sawing, sanding, and machining wood products can produce dust. Airborne wood dust can cause respiratory, eye, and skin irritation. The International Agency for Research on Cancer (IARC) has classified wood dust as a nasal carcinogen in humans.

Precautionary measures: If power tools are used, they should be equipped with a dust collector. If high dust levels are encountered, use an appropriate NIOSH-designed dust mask. Avoid dust contact with eyes and skin.

First Aid measure in case of irritation: In case of irritation, flush eyes or skin with water for at least 15 minutes.

7.7 Treating Exposed Panel and Backer Edges

All WoodWorks® Linear Solid Wood panels and backers are fully finished from the factory to protect from the elements.

All exposed panel edges from cuts or penetrations can be finished by using the finish stain for cut ends in coordinating finishes. Cut backer ends can be finished with black paint.

8. SPECIAL CONSIDERATIONS

8.1 Wall Installations

8.1.1 Panel orientation can be horizontal or vertical, but must be installed on an 96" O.C. module to ensure a 1" gap between panel ends.

8.1.2 3/4" plywood or furring should be attached to the wall structure to provide a surface that the WoodWorks Linear Solid Wood panels can be screw attached to (*Fig 14*).

8.1.3 Considering the panel orientation (horizontal or vertical), if furring is used the layout must provide screw attachment locations for the following screw spacing (*Fig 15*).

2 screws at every 24" O.C. backer, 8 total screws per full-size panel.

8.1.4 For panel attachment, use #6 x 1-1/4" or greater bugle head Hi-Lo or wood screws. Backers must be pre-drilled at screw locations to avoid splitting.

8.1.5 WoodWorks panels can be cut to fit receptacles or other wall fixtures. Use normal woodworking tools to achieve the desired opening. Attach additional backers (Item 7290GBL – ordered separately) for extra support as needed.

8.1.6 Follow instructions in Section 7.7 for treating exposed panel and backer edges.

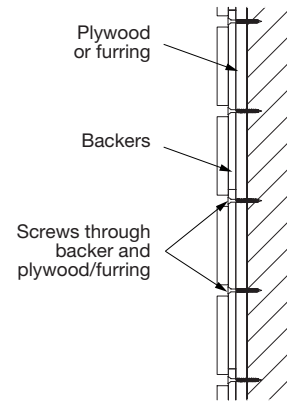

(Fig 14)

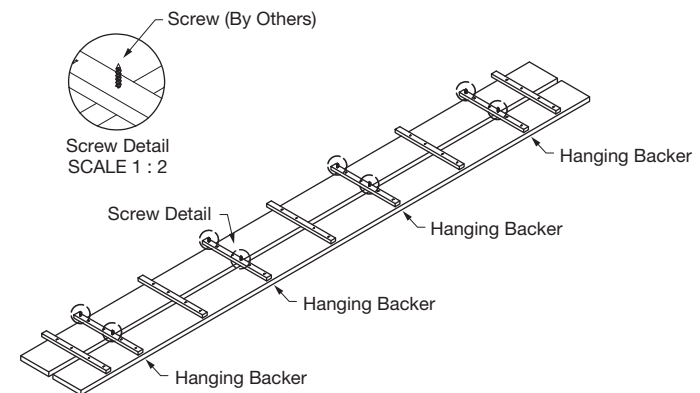

(Fig 15)

8.2 Sloped Installations

Refer to the Sloped Ceilings Technical Guide for general installation instructions for the suspension system build (seismic and non-seismic).

All sloped installations require a standard 24" x 24" grid layout, with 4' cross tees spaced 24" O.C.

Main beams must be installed parallel with the slope, resulting in the planks running perpendicular to the slope.

Panels are attached to the grid the same way as in a flat ceiling installation.

8.3 MEP Integration

Mechanical fixtures such as lights, speakers, and sprinklers should be installed into the acoustical suspension system before installing the WoodWorks® Linear Solid Wood panels. Fixtures can be installed at the suspension system height or flush with the bottom of the panel.

- Fixture weight or housing must not be supported by the panels
- Install additional cross tees to frame out fixtures as needed
- Supplemental or independent support for the fixtures may be required to prevent the total load from exceeding the deflection capability of the grid
- Refer to the ceiling plans for specific details

WoodWorks Linear Solid Wood panels can be cut to fit around fixture openings. Follow the steps in Section 7.7 for treating exposed panel and backer edges.

8.4 Pools

WoodWorks Linear Solid Wood panels cannot be installed in areas containing chemically treated water.

8.5 Exterior Installations

Panels are intended for interior use only.

9. SEISMIC INSTALLATION

9.1 For more details on seismic installations please see our brochure:
Seismic Design – What You Need to Know.

9.2 Suspension System

All seismic installations of WoodWorks® Linear Solid Wood panels must be installed per Seismic Design Categories D, E, and F. This is regardless of the total system weight. Heavy-duty Prelude® is required per ASTM E580.

All seismic installations require a standard 24" x 24" grid layout. Main beams are installed at 48" O.C., with 4' cross tees installed perpendicular to the main beams every 24" O.C., and 2' cross tees installed parallel to the mains at the midpoints of the 4' cross tees. The same grid components are required as listed in Section 4.1.

All grid connections to the wall are required to use the WoodWorks Heavy-duty Wall Anchor (Item 7100) in lieu of the BERC2 to meet the attached and unattached wall requirements (**Fig 16 & Fig 17**).

The installation must, in all cases, conform to the ASTM C636 requirements and the International Building Code. Installations may require independent engineering.

The requirements listed here represent the manufacturer's minimum acceptable installation recommendation, and may be subject to additional requirements established by the local authority having jurisdiction.

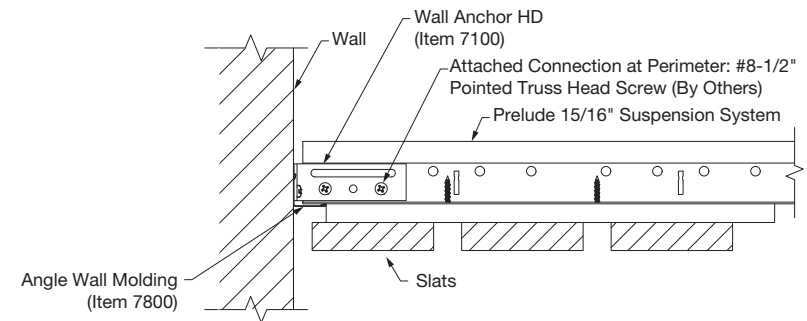

(Fig 16)

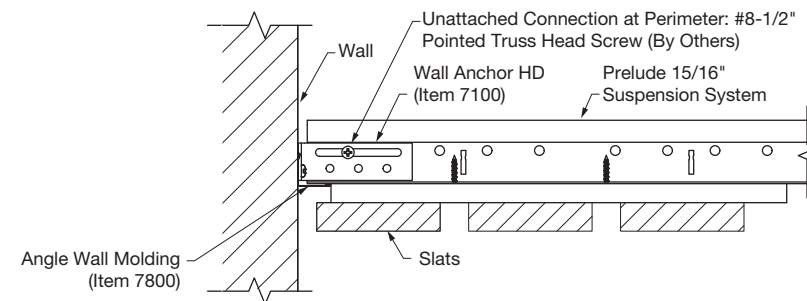

(Fig 17)

9.3 Seismic Rx Category D, E and F

- Ceiling installation should conform to basic minimums established in ASTM C636
- Minimum 7/8" wall molding
- Suspension system must be attached on two adjacent walls
- Opposite walls require 3/4" clearance
- BERCC2 maintains main beam and cross tee spacing; no other components required
- Heavy-duty systems as identified in ICC-ESR-1308
- Safety wires required on light fixtures
- Perimeter support wires within 8"
- Ceiling areas over 1,000 SF must have horizontal restraint wire or rigid bracing
- Ceiling areas over 2,500 SF must have seismic separation joints or full height partitions
- Ceilings without rigid bracing must have 2" oversized trim rings for sprinklers and other penetrations
- Changes in ceiling plane must have positive bracing
- Cable trays and electrical conduits must be independently supported and braced
- Suspended ceilings will be subject to special inspection
- Suspension layouts are the same as described in Section 4: Suspension System
- Connection to wall – See BPCS-4141 Seismic Design: What You Need to Know – Code Requirements Seismic Rx® Tested Solutions – SEISMIC RX® APPROACHES TO CATEGORY C and D, E, and F INSTALLATIONS
- Special bracing required – See BPCS-4141 Seismic Design: What You Need to Know – Code Requirements Seismic Rx Tested Solutions – Bracing and Restraint for Seismic Installations
- Seismic separation joints – See BPCS-4141 Seismic Design: What You Need to Know – Code Requirements Seismic Rx Tested Solutions – Seismic Separation Joints

9.4 Panel Attachment

All WoodWorks® Linear Solid Wood panels must be mechanically secured to the suspension system for installations in IBC Seismic Design Categories C, D, E, and F.

Position the WoodWorks Linear Solid Wood panels on the suspension system and direct screw attach to the suspension system using #6 x 1-1/4" bugle head Hi-Lo screws.

Eight screws are required for each full-size panel (two per backer that aligns with grid), following the placement detailed in Section 7.2.1.

Testing conducted at the Structural Engineering Earthquake Simulation Laboratory, located at the State University of New York – Buffalo campus, produced satisfactory results.

NON-SEISMIC GRID (REFER TO SECTION 9.2 FOR SEISMIC INSTALLATIONS)



SECTION DETAIL

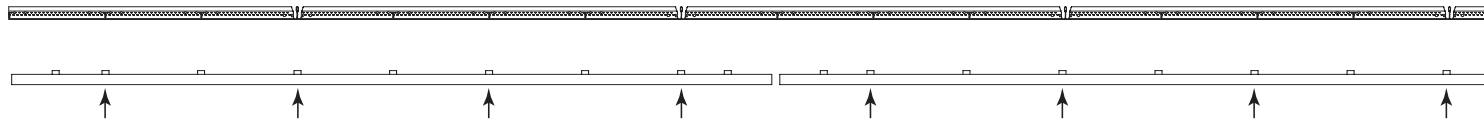

WOODWORKS® LINEAR SOLID WOOD PANELS				
Item #	Item Name	Included with Planks	Sold by the:	Pcs/Ctn
8176W1G__	Interior only 12" x 96" panel with nominal 3" planks	-	piece	bulk shipped
8177W1G__	Interior only 12" x 96" panel with nominal 5" planks	-	piece	bulk shipped
SUSPENSION AND ACCESSORIES				
Item #	Item Name	Included with Planks	Sold by the:	Pcs/Ctn
7301	Prelude® XL® 12' HD Main Beam	no	carton	20
XL7341	Prelude 4' Cross Tee (1-11/16" bulb)	no	carton	60
XL8320	Prelude 2' Cross Tee (1-11/16" bulb)	no	carton	60
7800	12' "L" Angle Wall Molding	no	carton	30
7891	12' 12-gauge hanger wire	no	carton	140
5687	Backer Clips (optional) (for use with 3" plank panels only)	no	pail	250
5671___	8' Ledger	no	piece	bulk shipped
6657	BioAcoustic™ Infill Panel in Black	no	carton	10
Premium	Black Fleece (premium option) specify thru ASQuote	yes, when specified	n/a	
By Others	1-1/4" Drywall sharp-point screws	no	sold by others	
7146H4L96___	4" Solid Wood Trim – for solid wood panels/4 clips, Item 5925 included	no	piece	1
7146H6L96___	6" Solid Wood Trim – for solid wood panels/4 clips, Item 5925 included	no	piece	1
5457GAL1___	WoodWorks® Solid End-Stain (Gallon)	no	piece	1
5457QT1___	WoodWorks Solid End-Stain (Quart)	no	piece	1
7290GBL	Flat Backer Kit	no	carton	18
5925	Replacement Trim Clip to fasten wood trim to suspension system	no	carton	1

When specifying or ordering, include the appropriate 3-letter color suffix that coordinates with your WoodWorks ceiling: (e.g., 8176W1 G M P).

MORE INFORMATION

For more information, or for an Armstrong Ceilings representative, call 1 877 276-7876.

For complete technical information, detail drawings, CAD design assistance, installation information, and many other technical services, call TechLine customer support at 1 877 276-7876 or FAX 1 800 572-TECH.

All trademarks used herein are the property of AWI Licensing LLC and/or its affiliates.

© 2023 AWI Licensing Company Printed in the United States of America

BPLA-297853-223

