

WoodWorks® Linear Veneered Open

Assembly and Installation Instructions



1. GENERAL

1.1 Product Description

WoodWorks® Linear Veneered Open consists of unperforated nominal 4-1/2" and 6" wide planks that are 8' long. The planks are designed to install on a linear carrier with factory-applied clips. Each plank width incorporates a 3/4" reveal between planks that is covered by black fleece applied to the back side of the planks at the top of the reveal.

1.2 Material & Surface Finish

WoodWorks Linear Veneered Open planks are constructed of fire-retardant particle board with real wood veneer. The exposed edges along the length of the planks are edge-banded with a similar finish as the face, and the ends of the planks are unfinished. Edge-banded ends are available upon request.

1.3 Storage and Handling

All ceiling components should be stored in a dry interior location and should remain in the original packaging prior to installation to avoid damage. The materials must be stored off the floor in a flat, level condition. Do not store in spaces with humidity greater than 55% RH or lower than 25% RH, or with temperatures above 86°F or lower than 50°F. Use proper care when handling to avoid damage or soiling.

CAUTION: Use proper care and caution when handling suspension systems due to the sharp edges on all exposed clips.

1.4 Site Conditions

Building areas that will receive ceiling planks must be free of construction dust and debris. Installation of the products must be carried out where the temperature is between 50°F and 86°F and relative humidity levels maintained between 25% RH and 55% RH. These temperature and humidity conditions must be met throughout the lifetime of the ceiling.

Real wood and wood composite products are natural building materials and they will react to changes in humidity. (Wood tends to contract with lower humidity and expand with higher humidity.)

Wood may also have a tendency to warp, twist, or bow due to the natural stresses in the components and humidity changes. Be aware of these natural tendencies when evaluating the products.

It is also necessary for the area to be enclosed and for the HVAC systems to be functioning and in continuous operation. All wet work (plastering, concrete, etc.) must be complete and dry. These products cannot be used in exterior applications.

To ensure that the ceiling planks have stabilized to the current building conditions prior to their installation, the planks must be placed in an environmentally stable building location for a minimum of 72 hours.

1.5 Veneer Options

WoodWorks Linear Veneered Open ceiling planks are available in 14 standard real wood veneer options: Maple (NMP), Light Cherry (NLC), Walnut (CWA), Redux Wood Wheat (CRW), Plain Slice White Maple (NWM), Plain Slice White Ash (NWA), Plain Slice White Oak (NOK), Plain Slice Cherry (NPC), Plain Slice Walnut (NWN), Vertical Grain Fir (NVF), Rift White Oak (NRO), Quartered Walnut (NQW), Quartered Sapele (NQS), and Quartered Mahogany (NQM). Natural variations in color and grain are characteristic of wood products. To maximize visual consistency, planks should be unpacked and examined collectively to determine the most desirable arrangement for installation. Consult the Hardwood Plywood and Veneer Association (HPVA) for additional information on veneers.

1.6 Cleaning Recommendations

WoodWorks® Linear Veneered Open ceiling planks can be cleaned with a soft, dry cloth.

1.7 Plenum

WoodWorks Linear Veneered Open ceiling planks attach to a linear carrier with factory-applied clips. The planks do not travel into the plenum for installation, so minimal plenum space is required.

1.8 Fire Performance and Sprinklers

As with other architectural features located at the ceiling, WoodWorks Linear Veneered Open ceiling planks may obstruct or skew the planned fire sprinkler water distribution pattern, or possibly delay or accelerate the activation of the sprinkler or fire detection system by channeling heat from a fire either towards or away from the device. Designers and installers are advised to consult a fire protection engineer, NFPA 13, and their local codes for guidance where automatic fire detection and suspension systems are present.

1.9 Ordering Considerations

Be sure to account for extra material that is normally needed for linear wood installations. Typical installations should consider ordering at least 5% extra material. Up to 10% more may be needed for odd size or diagonal installations. It is the customer's responsibility to plan each layout and order the correct amount of installation material needed, taking into account their design and the dimensions of the nominal 8' long by 4-1/2" or 6" wide planks.

2. ACCESSORIES

2.1 Linear Wood Panel Splice (Item 5843) (*Fig 1*).

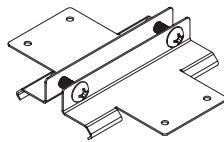

2.2 Radius Clip for Faceted Grid Application in black finish (Item RC2BL) (*Fig 2*).

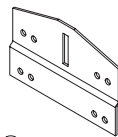

2.3 Rigid Attachment Clip in black finish (Item 6459BL) (*Fig 3*).

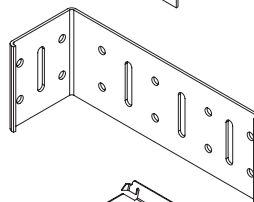

2.4 Replacement WoodWorks Linear Veneered Open Grid Tee Snap-in Clip (Item 5373) (*Fig 4*).

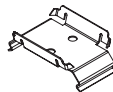

3. DESIGN CONSIDERATION

3.1 Plank Movement & Expansion Joints

Because the planks are butted together end-to-end, installations are required to account for 1/4" of movement for every 8' of run in the plank length direction.

- Runs up to 24' can account for this movement at the perimeters. Available molding includes 1-1/2" angle molding (Item 7805) and 2" shadow molding (Item 7823).
- Runs greater than 24' must account for movement by using expansion joints so there are no runs of planks longer than 24'. See Section 6 for additional details on expansion joints.

3.2 Accessibility

The linear wood planks are not accessible after installation. Refer to Section 8 for additional information on creating an access door in the field.

3.3 Exterior Installation

WoodWorks Linear Veneered Open ceiling planks are not intended for exterior use.

3.4 Ceiling Plank Layout

The ceiling plank layout should have perimeter planks equal in width on opposite ends. These cut perimeter planks should be more than 50% of their original width. See Section 12 for cutting instructions. If the plank is less than 50% of the original width, divide the room dimension by the nominal width of the plank (4-1/2" or 6"). Determine the remainder, add one full plank width, and divide by two to determine the width of the border plank.

Example: 6" nominal plank width; room dimension is 10'-4". Divide 10'-4" by 6" = 20 full Sections with 4" remainder. Add 4" to 6" = 10" divided by 2 = 5" border plank with 19 full rows of planks. This will create the best visual.

4. SUSPENSION SYSTEM INSTALLATION

4.1 General

WoodWorks Linear Veneered Open ceiling planks are supported by linear carriers installed no more than 2' O.C. The heavy-duty linear carriers are supplied with factory-applied linear clips spaced to accommodate either the nominal 4-1/2" or 6" wide planks.

4.2 Load Capacity

WoodWorks® Linear Veneered Open ceiling planks weigh 0.8 LBS/LF for 4-1/2" module and 1.2 LBS/LF for 6" module. The heavy-duty linear carriers supplied as part of the system are capable of carrying the weight of the planks in the manner prescribed.

4.3 Preparation

Determine the desired height of the new ceiling. Strike a level line around the perimeter of the area to indicate the height of the top of the molding to be installed. Determine the desired direction of the linear wood ceiling.

4.4 Perimeter Molding

If the installation is to run from wall to wall, install wall molding on a level line around the perimeter of the area. The natural expansion and contraction of wood products must be considered when planning the installation. Because the planks are butted together end-to-end, installations are required to account for 1/4" of movement for every 8' of run in the plank length direction. This space can be at the moldings or by introducing expansion joints within the field of the ceiling (see Section 6). Available molding includes 1-1/2" Angle Molding (Item 7805) and 2" Shadow Molding (Item 7823) (**Fig 5**). **NOTE:** Black is a special color that can be ordered with extended lead time. Fasten the molding with screws appropriate for the wall construction (supplied by others).

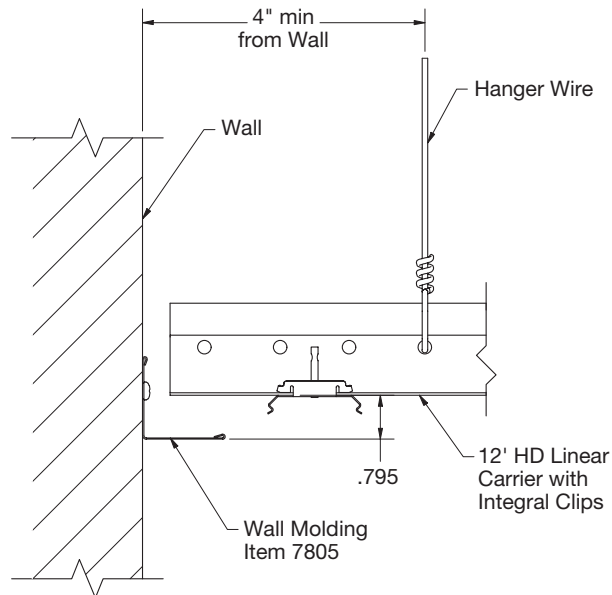

(Fig 5)

4.5 Hanger Wires

Secure 12-gauge hanger wires to the structure above. The linear carrier must be supported by hanger wires no more than 24" from the perimeter wall and then 48" O.C. Bend the hanger wires so the bottom of the linear carriers are 7/8" above the bottom of the molding when using angle molding (Item 7805) (**Fig 5**). When using shadow molding (Item 7823), wires should bend about 3/4" so the bottom of the linear carrier sits on top step of shadow molding.

4.6 Linear Carriers

Linear carriers are to be spaced no more than 6" from the walls and 2' O.C. across the room. (**NOTE:** This is for flat installations. For faceted grid, see Section 9.) The linear carrier will run perpendicular to the desired plank length direction.

The linear carrier will need to be cut based on the following steps:

4.6.1 Measure the width of the room in the direction perpendicular to the length of the planks. Divide the dimension by the width of the plank plus reveal, 4-1/2" for narrow planks or 6" for the wider version, and determine the remainder in inches. Add the width of a single plank to the remainder and divide by two. This is the width of your border planks.

4.6.2 Measure from the starting wall the dimension determined in Section 4.6.1 minus 1" for narrow planks (4-1/2") or 1-3/4" for wide planks (6") and stretch a guide string from one side of the room to the other. Cut the carrier so that the edge of the first clip on each carrier will align with the string line (**Fig 6**).

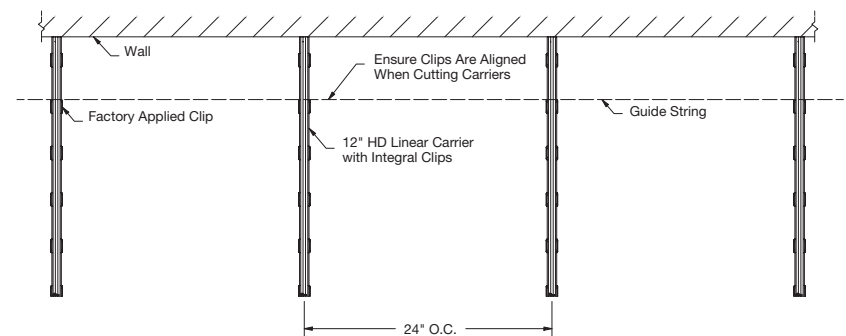

(Fig 6)

Hang the carriers on the hanger wires, align the clips with the guide string at the starting end. Join carriers together to reach the other end of the installation.

4.6.3 Installation will not use cross tees, therefore, it is recommended to use a 2' stabilizer bar every 6' along the linear carrier to maintain the 2' spacing (**Fig 7**). Stabilizer bar will then be removed as the plank installation progresses (**Fig 8**). Once removed, stabilizer bars can be saved and be re-used in any future project.

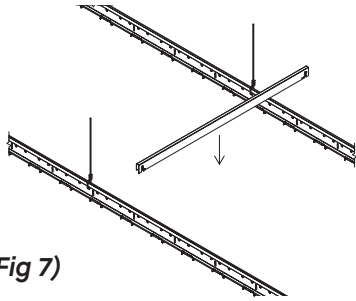

(Fig 7)

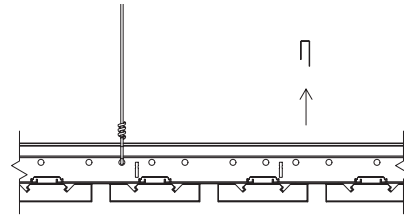

(Fig 8)

CAUTION: The exposed edges of the clips on the linear carrier are very sharp. Be cautious in handling and installing near the carriers.

5. PLANK INSTALLATION

5.1 Starting Perimeter Plank Row

5.1.1 Cut the first row of planks to the correct width. Position the plank grooves against the factory-applied clips on the linear carrier. If the results of this cut prevent the clip from engaging the grooves on the back of the plank, remove the clip from the carrier and attach the first row of planks by inserting 1/2" long screws through the flange of the main beam into the back of the plank. A 1/8" thick shim must be inserted between the plank and suspension system at every location where the clip has been removed.

5.1.2 If the end of the first plank in any row ends directly under a carrier, cut the one end of the plank so the other end of the plank falls between carriers no less than 3" from carrier (**Fig 9**).

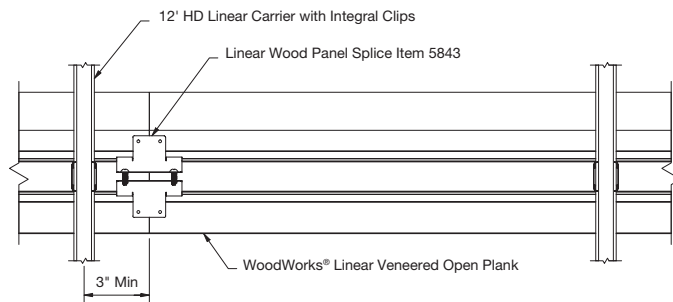

(Fig 9)

5.1.3 Position the starting end of each row of planks as described in Section 5.1.1 (temporary spacers can be used for this), and the black fleece backer toward you, push the plank into the clips on the carriers allowing the clip to enter the grooves on the back of the plank. Hold the carrier down while pushing up on the plank. Make sure the clip is fully entered into the grooves. You should hear an affirmative “snap” noise once the plank is in its proper position. Work from one end of the strip to the other. Hand pressure should be enough to seat a clip into the kerfs fully (**Fig 10**).

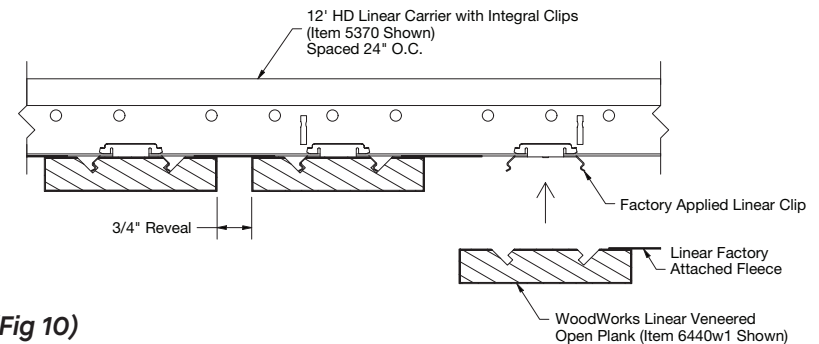

(Fig 10)

NOTE: Should a clip fail to hold for any reason, insert a 1/2" long sharp point screw through the dimple on the flange of the main beam and into the back side of the plank.

CAUTION: Be careful not to damage a clip. If a clip is damaged, a replacement clip can be put on from a spare piece of carrier.

5.3 Plank Splices

When installing additional planks end-to-end to complete a row, butt tightly together and secure each joint with a splice (Item 5823). Insert the splice into the grooves on the back of the planks and tighten the screws to secure the connection (**Figs 11 - 14**).

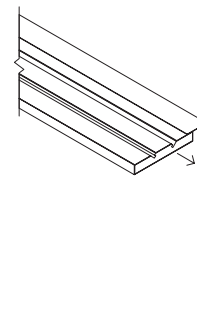

(Fig 11)

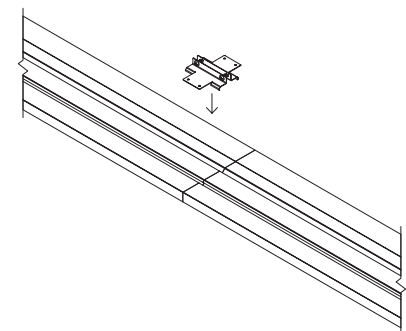

(Fig 12)

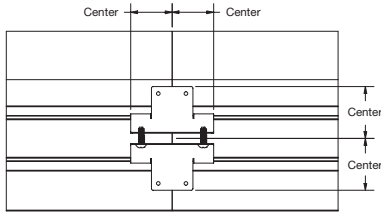

(Fig 13)

Holes are provided in the splice for the insertion of the screws into the back of the planks. Drill pilot holes in the wood; this is only required where warp or twist causes the plank ends to misalign, or in severe seismic applications (See Section 13).

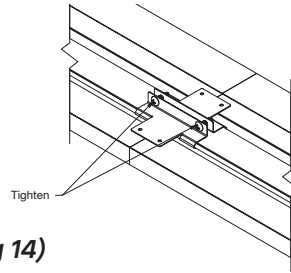

(Fig 14)

5.4 Last Plank in a Row

Cut the last wood plank to provide the required end clearance and install to complete the row.

5.5 Field Plank Installation

As you start the second row of planks, make sure the black fleece from the first row lays over the back side of the adjacent planks in the second row (Figs 15 & 16). If there are any gaps between the fleece at the plank end joints, cut the scrap of fleece from a leftover plank, apply a drop of glue to it, and apply the patch over the gap on the back of the fleece.

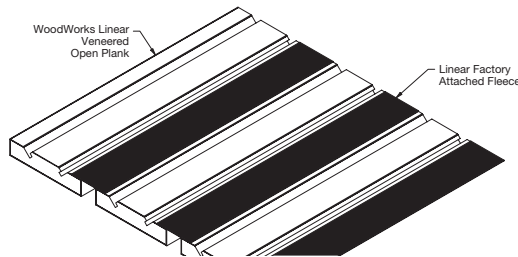

(Fig 15)

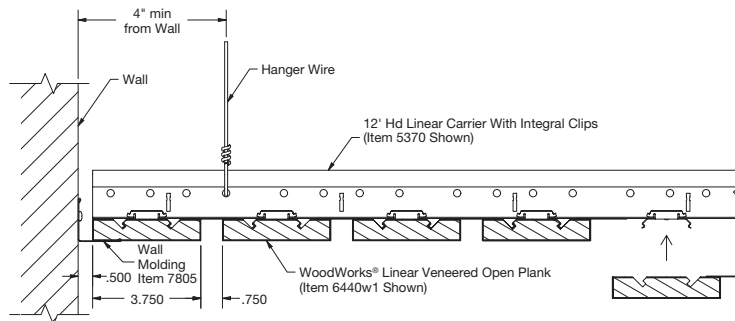

(Fig 16)

5.6 Last Perimeter Row

Continue installation as noted in Section 5.5 to the other end of the room. Do not install the last three rows in full width planks until the final row is completed. Cut and install the border as described in Section 5.1.1, then complete the installation of full-width planks.

6. EXPANSION JOINTS

As referenced in Section 3.1, the natural expansion and contraction of wood products must be considered when planning the installation. Because the planks are butted together end-to-end, installations are required to account for 1/4" of movement for every 8' of run in the plank length direction.

- Runs up to 24' can account for this movement at the perimeters (as addressed in Section 4.4).
- Runs greater than 24' must account for movement by using expansion joints so there are no runs of plank longer than 24'.

Expansion Joint Guidance:

- Linear carriers must be installed within 4" of each side of the expansion joint.
- If cut plank ends are exposed at the expansion joint, they should be edge-banded, and the gap can be covered from above with black BioAcoustic™ Infill (Item 6657).
- Cut plank ends can alternatively be concealed by an independently supported component (e.g. Axiom® Slip Joint)

(Fig 17)

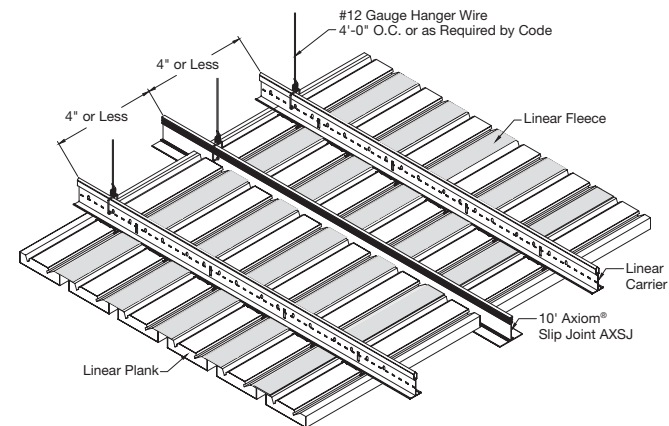

(Fig 17)

7. PERIMETER TREATMENT

When the installation is not slated to run from wall to wall, cut the ends of the planks before installing and paint or edge-band exposed ends. (**CAUTION:** The fleece could jam the saw blade. Consider taping it down to the wood first.) Then stain or edge-band the cut ends of the planks.

The first and last carriers must be no more than 4" from the sides of the floating installation. An alternate method is to cap the end of the installation using either veneered trim, available in 4", 6", and 8" or Axiom® Vector Inverted.

7.1 Floating Trim

When the installation is not slated to run from wall to wall, cut the ends of the planks before installing and paint or edge-band exposed ends. (**CAUTION:** The fleece could jam the saw blade. Consider taping it down to the wood first.) Then stain or edge-band the cut ends of the planks.

Veneered and Axiom® trim can be used to cap the perimeters of a cloud installation.

7.1.1 Axiom Trim

The Modified Twist Clip (Item 5948) or Adjustable Trim Clip (Item 7239) can be used to set the grid at the correct height in relation to the trim flange and fasten the linear carrier to the Axiom Vector Trim. (**Fig 18**).

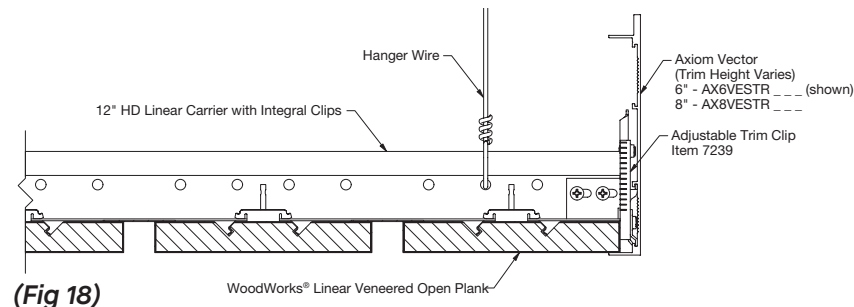

(Fig 18)

7.1.2 Veneered Trim

Veneered trim should be used for straight conditions only, no curves. Cut the trim to fit as required and join the pieces with a biscuit joint. Use a #20 biscuit and wood glue to join two pieces of trim together on a straight run or at a mitered corner. Use one biscuit for 4" and two biscuits with 6" and 8" trims. A finishing pin nail can be used to hold your mitered corners together while your biscuit joint dries. The 5925 Clip (included with trim) is used to fasten trim to the suspension system every 2' O.C. (**Fig 19**).

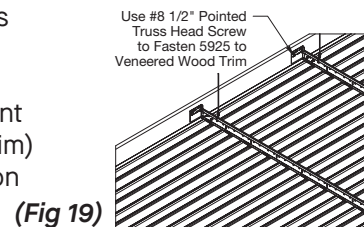

(Fig 19)

Use #8 × 1/2" pointed truss-head screws (by others) to attach 5925 to trim. It is recommended that hanger wires are no less than 4" from the perimeter. This will allow the 5925 clip to fasten to the grid without interference (**Fig 20**).

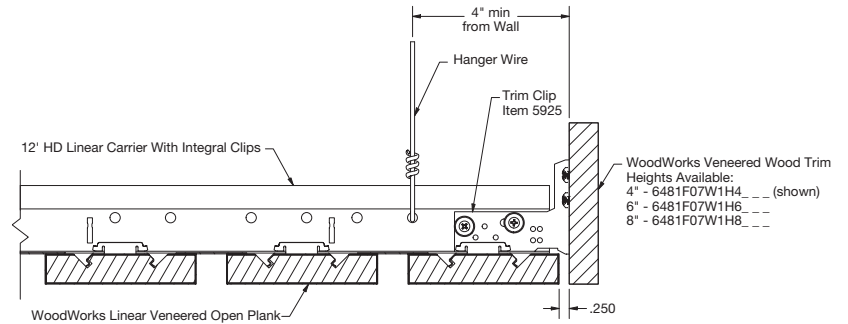

(Fig 20)

8. ACCESS OPTIONS

To create an access door in the field, first attach several field cut planks together with field cut carriers. Then use two pieces of 1-1/2" channel at least 3' long to act as outriggers to support the access panel. The channels should be attached at the top to the linear carriers with UTC clips. The weight of the access door will rest on the adjacent carriers. If the face of the access door rests slightly lower than the rest of the installation, fasten a metal shim to the top side of the suspension system where the 1-1/2" channel rests on it (**Figs 21 & 22**).

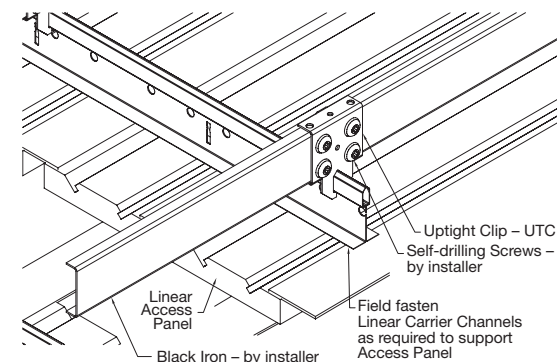

(Fig 21)

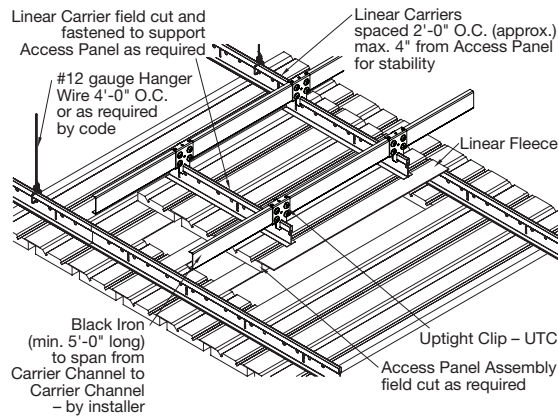

(Fig 22)

9. FACETED APPLICATIONS

9.1 Linear wood can be installed to show a curved look by faceting the linear carriers. Follow these guidelines for faceted applications.

To facet the linear carriers, field cuts must first be made to the suspension system. Cuts should be centered exactly between the linear clips.

9.2 Bend the suspension system at the cuts to the specified curve. A 12" radius is the tightest recommended radius for these applications. See examples of convex and concave curves as detailed (Figs 23 & 24). The reveal will vary according to the tightness of the curve.

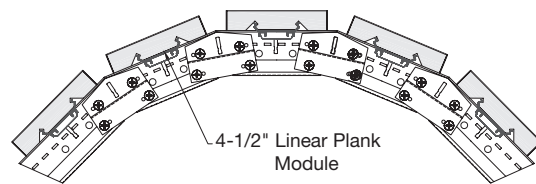

(Fig 23)

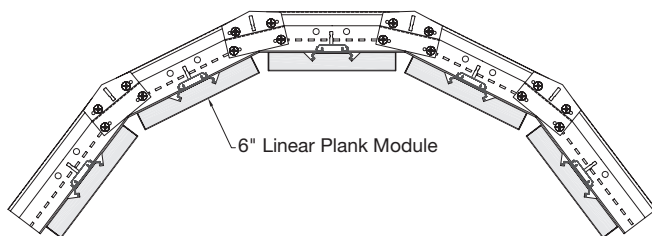

(Fig 24)

9.3 To bend the suspension system correctly, it is recommended to draw the specified curve first on an appropriate background material, like plywood. Then, screw a flexible drywall track to the backer to match the curve. Take the field cut linear carrier and match it to the flex curve and clamp it into place.

9.4 Position an RC2 radius clip (typically used in drywall grid installations) over each cut in the carrier to stabilize the curve. Screw the RC2 clip over each cut with four #6 x 7/16" sharp point screws per clip – two screws each on either side of the cut suspension system (Fig 25).

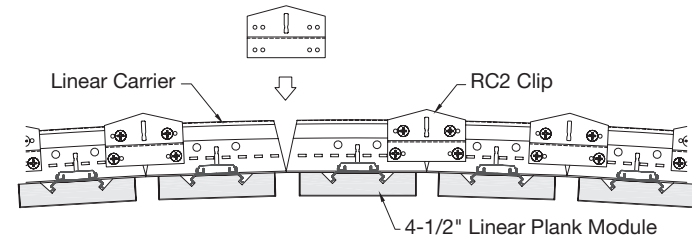

(Fig 25)

9.5 Install the newly faceted linear carriers. Space the hanger wires every eight planks (or clips) for 6" modules or every 11 planks (or clips) for the 4-1/2" modules.

9.6 Proceed with the linear plank installation by installing planks to the faceted carriers.

CAUTION: The exposed edges of the clips on the linear carriers are very sharp. Be cautious in handling and installing near the carriers.

9.7 Add a strut (brace) to structure every 8' along the first row of main beams. Repeat on additional rows at 12' centers.

9.8 For perimeter wall trim on curved applications, use the 1-1/2" angle molding (Item 7805). (NOTE: Black is recommended. This is a special order color with extended lead time.) Cut and install the angle molding progressively with the cuts centered between the planks after each plank is installed. Curve the molding by cutting the back leg with a straight cut and bending it to the specified shape.

NOTE: Each flat face of molding will have a plank resting on it. The cut or joint of the wall molding should match the cut in the faceted linear carrier.

10. WALL INSTALLATION

The following instructions are for installations with the planks running horizontally across the wall. Installations with the planks running vertically up the wall are not recommended. Install wood furring strips horizontally, securing them to wall studs or a solid wall with appropriate fasteners for the substrate. Spacing between furring should not be more than 24". The first furring strip at the bottom should be elevated from the floor by no more than 8". The last furring strip at the top should be 8" from the existing ceiling.

Install Rigid Attachment Clips (Item 6459BL) to the furring strips, flush, going up the wall and 24" O.C. (Figs 26 - 28) The first and last carriers must be no more than 4" from the end of the plank. You must place a 3/4" expansion joint at every 24' run of plank. Splice plate installations will be blind and will need a Phillips screwdriver as detailed.

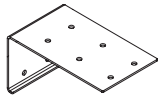

6459BL
Rigid Attachment Clip

(Fig 26)

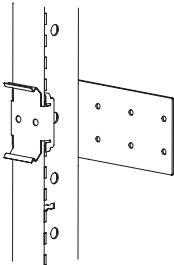

(Fig 27)

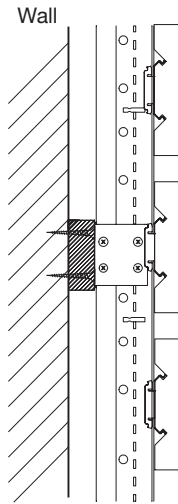

(Fig 28)

Install panels from the bottom up with felt down.

For receptacle cutouts or other wall fixtures, trim or finish edges with the appropriate molding or tape (fastcap).

11. CEILING-TO-WALL TRANSITIONS

11.1 Ceiling-to-Wall transition - 90 degree (Fig 29)

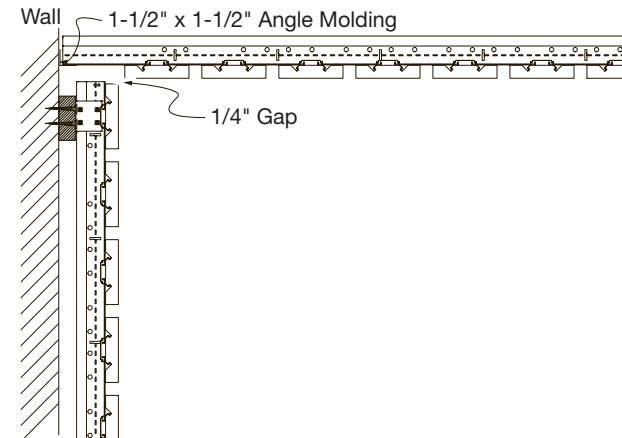

(Fig 29)

Use 1-1/2" angle molding. Install the ceiling and wall planks per instructions given leaving a 1/4" gap between the ceiling planks and the last wall plank. If installing adjacent walls, leave 1/4" gap between the end of the plank and the face of the adjacent plank. For exposed plank ends, use fastcap edge-banding matching the wood veneer.

11.2 Ceiling-to-Wall Transition – Faceted (Fig 30)

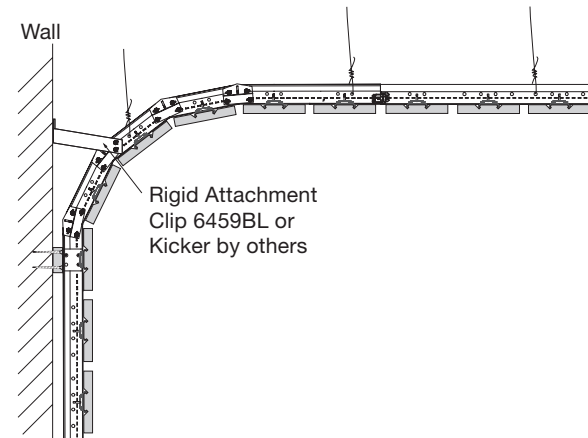

(Fig 30)

11.2.1 WoodWorks® Linear Veneered Open ceiling planks can be installed to create a curved transition from ceiling to wall by faceting the suspension system. (See Section 10 Faceted Applications to correctly facet the suspension system.)

If possible, make the transition from ceiling to wall from one WoodWorks® linear carrier. Attach the curved transition to the wall as stated in Section 10. Use Rigid Attachment Clips (Item 6459BL) or a rigid kicker (by others) to stabilize the curved section of the transition. Attach hanger wire to the deck starting 6" from the wall and then use 24" spacing going up the curved carrier.

11.2.2 Use of WoodWorks Linear accessories for curved installations is not recommended. When trim accessories are required, the installer must field miter, join, and attach the trim to exactly match the faceted panels.

11.2.3 If installation is not wall to wall, treat the exposed ends with fastcap edge-banding matching the wood veneer or build a curved bulkhead to hide untreated ends.

WoodWorks Linear curved transitions are single wall only.

12. CUTTING

When you cut a plank to length, first tape the fleece to the wood and then cut the plank with normal woodworking tools of your choice.

Penetrations for sprinklers (or other fixtures) can be accomplished by simple interruption of the wood planks at those locations or by using normal woodworking tools to cut access in the planks.

CAUTION: WOOD DUST. Sawing, sanding, and machining wood products can produce dust. Airborne wood dust can cause respiratory, eye, and skin irritation. The International Agency for Research on Cancer (IARC) has classified wood dust as a nasal carcinogen in humans.

Precautionary measures: If power tools are used, they should be equipped with a dust collector. If high dust levels are encountered, use an appropriate NIOSH-designed dust mask. Avoid dust contact with eyes and skin. First Aid measure in case of irritation: In case of irritation, flush eyes or skin with water for at least 15 minutes.

13. SEISMIC INSTALLATION

WoodWorks Linear Veneered Open ceiling planks have been engineered for application in seismic areas. This system has been successfully tested in applications simulating Seismic Design Categories D, E, and F. For applications in seismic zones, review the following guidelines.

The suspension system is to be hung using #12 gauge steel suspension wires at 4' O.C. Additional perimeter wires should be installed within 8" of all walls and installed 2' O.C. to support the perimeter grid members. All of the vertical wires were attached to the ceiling suspension member and to structure with a minimum of 3 turns within 3" of each connection.

Secure the ceiling to the wall on two adjacent sides using heavy-duty wall anchors (Item 7100). On the "end" wall, apply heavy-duty wall anchors to secure the ends of the carriers to the wall. Every 4' a row of planks is to be screwed at every carrier. One end of this row is to be attached to the wall. Use two #6 × 7/16" sharp point screws to attach an XTAC clip to the back of the plank. Use screws appropriate for the wall construction to secure the other leg of the clip to the wall. Join the ends of the planks in these rows by inserting four (4) #6 × 7/16" screws through the holes in the splice plates and into the back of the wood. The other two sides must not be attached to the walls and must have 3/4" clearance from the wall (**Figs 31 & 32**).

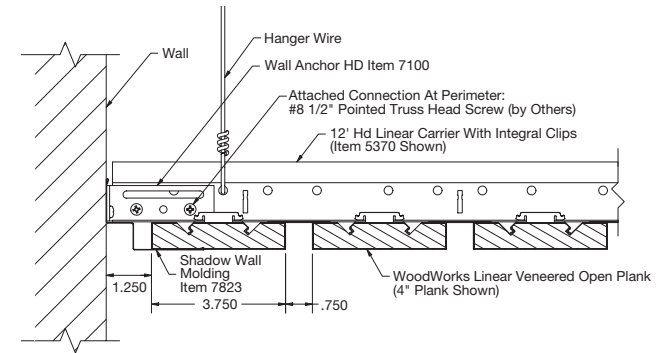

(Fig 31)

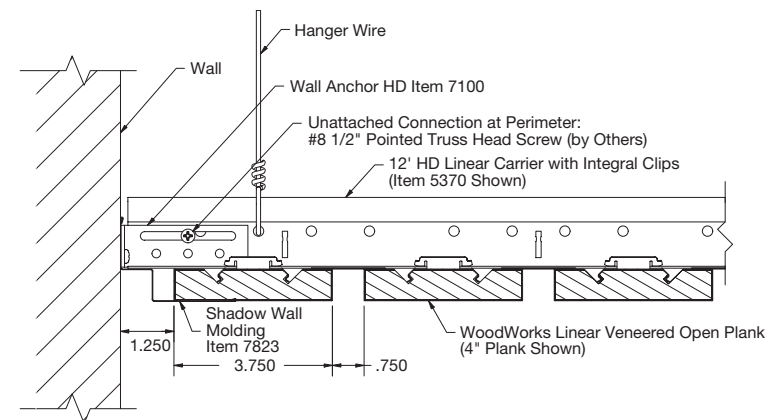

(Fig 32)

Check local code for the need for lateral bracing and/or compression posts/splay wires, perimeter wires, and for additional installation requirements for faceted or curved ceiling installations.

| Item No.◆ | Description | Ordered Separately/ Included With | Required for Install |
|--|---|-----------------------------------|------------------------|
| WOODWORKS® LINEAR VENEERED OPEN | | | |
| 6440F01W1 _ _ _ | Nominal 4-1/2" Linear Planks | Ordered Separately | Based on Design |
| 6460F01W1 _ _ _ | Nominal 6" Linear Planks | Ordered Separately | Based on Design |
| Suspension System | | | |
| 5370 | 12' HD Linear carriers (Concealed) with Integral Clips (factory-applied) for Nominal 4-1/2" Modules | Ordered Separately | Yes |
| 5371 | 12' HD Linear carriers (Concealed) with Integral Clips (factory-applied) for Nominal 6" Modules | Ordered Separately | Yes |
| 7891 | 12-Gauge Hanger Wire | Ordered Separately | Yes |
| Perimeter Trim | | | |
| 7805 | 1-1/2" Angle Wall Molding | Ordered Separately | Based on Design |
| 7823 | 2" Shadow Molding | Ordered Separately | Based on Design |
| 6481F07W1H4 _ _ _ | 4" Veneer Trim - For Veneer Panels/Clips Included | Ordered Separately | Based on Design |
| 6481F07W1H6 _ _ _ | 6" Veneer Trim - For Veneer Panels/Clips Included | Ordered Separately | Based on Design |
| 6481F07W1H8 _ _ _ | 8" Veneer Trim - For Veneer Panels/Clips Included | Ordered Separately | Based on Design |
| AX_VESTR _ _ _ | Axiom® Vector Straight Trim - Recommended in Black | Ordered Separately | Based on Design |
| Accessories | | | |
| 6408D5 _ _ _ | Veneer Edge-banding | Ordered Separately | Based on Design |
| 5925 | Replacement Trim Clip | Ordered Separately | Based on Design |
| 7100 | Heavy-duty Wall Anchor – Seismic | Ordered Separately | Yes – Seismic D,E, & F |
| 7239 | Adjustable Trim Clip (ATC) | Ordered Separately | Based on Design |
| BERC2 | 2" Beam End Retaining Clip | Ordered Separately | Based on Design |
| SH12 | Support Hanger | Ordered Separately | Based on Design |
| XTAC | Cross Tee Adapter Clip | Ordered Separately | Yes – Seismic D,E, & F |
| 5843 | Linear Wood Panel Splice | Ordered Separately | Yes |
| RC2BL | Radius Clip for Faceted Grid Application (Black) | Ordered Separately | Based on Design |
| 6459BL | Rigid Attachment Clip (Black) | Ordered Separately | Based on Design |
| 5373 | Replacement WoodWorks Linear Veneer Plank Grid Tee Snap-in Clip | Ordered Separately | – |

◆ When specifying or ordering, include the appropriate 3-letter color suffix (e.g., 6440F01W1 N M P)

MORE INFORMATION

For more information, or for an Armstrong Ceilings representative, call 1 877 276-7876.

For complete technical information, detail drawings, CAD design assistance, installation information, and many other technical services, call TechLine customer support at 1 877 276-7876 or FAX 1 800 572-TECH.

All trademarks used herein are the property of AWI Licensing LLC and/or its affiliates.
© 2023 AWI Licensing Company Printed in the United States of America

BPLA-297443-623



Armstrong®
World Industries