

WoodWorks® Tegular & WoodWorks® TechZone®

Assembly and Installation Instructions



1. GENERAL

1.1 Product Description

WoodWorks® Tegular ceiling panels consist of perforated and unperforated 12" x 48", 12" x 72", 24" x 24", 24" x 48", and 24" x 72" panels designed to be installed on heavy-duty 9/16" wide T-Bar suspension systems.

WoodWorks® TechZone® ceiling panels consist of perforated and unperforated 24" x 42", 27" x 30" and 30" x 30" panels designed to be installed on conventional 9/16" wide T-Bar suspension systems.

1.2 Surface Finish

All wood panels are constructed of wood chips factory bonded together between two layers of wood veneer finish. All exposed edges are banded with the same finish as the face.

1.3 Storage and Handling

The ceiling components must be stored in a dry interior location and must remain in cartons prior to installation to avoid damage. The cartons must be stored in a flat, horizontal position. The protectors between panels should not be removed until installation. Proper care should be taken when handling to avoid damage and soiling. Do not store in unconditioned spaces with humidity greater than 55% or lower than 25% RH and temperatures lower than 50°F or greater than 86°F. Panels must not be exposed to extreme temperatures, for example, close to a heating source or near a window where there is direct sunlight.

1.4 Site Conditions

WoodWorks Tegular ceiling materials should reach room temperature and have a stabilized moisture content for minimum of 72 hours before installation. (Remove plastic wrap to allow panels to climatize.) They should not, however, be installed in spaces where the temperature or humidity conditions vary greatly from the temperatures and conditions that will be normal in the occupied space.

1.5 HVAC Design & Operation

Proper design for both supply air and return air, maintenance of the HVAC filters, and building interior space are essential to minimize soiling. Before starting the HVAC system, make sure supply air is properly filtered and the building interior is free of construction dust.

1.6 Temperature & Humidity During Installation

WoodWorks panels are interior-finish products designed for installation in temperature conditions between 50°F and 86°F, in spaces where the building is enclosed and HVAC systems are functioning and will be in continuous operation. Relative humidity must not fall below 25% or exceed 55%. There must be proper ventilation of the plenum in high moisture areas. All plaster, concrete, terrazzo, or any other wet work should be completely dry. All windows and doors should be in place. The heating, ventilating, and air-conditioning systems should be installed and operable where necessary to maintain proper temperature and humidity conditions before, during, and after installation of the WoodWorks panels.

1.7 Color

WoodWorks panels are made with a variety of real wood veneers. Natural variations in color and grain are characteristic of wood products. To maximize visual consistency, panels should be unpacked and examined collectively to determine the most desirable arrangement for installation. Where consistency is critical, Armstrong can offer custom solutions to meet your budget and aesthetic requirements. Consult HPVA for additional information on veneers and veneer grades.

1.8 Cleaning Recommendations

WoodWorks® Tegular and WoodWorks® TechZone® panels can be cleaned with a soft, dry cloth.

2. PANEL EDGES

2.1 General

The edges of the WoodWorks Tegular panels feature 1/8" thick splines which support the panel on the grid flanges.

3. SUSPENSION SYSTEM

3.1 General

The requirements listed here represent the manufacturer's minimum acceptable installation recommendations, and may be subject to additional requirements established by the local authority having jurisdiction.

- All installations should follow ASTM C636
- All references to suspension component duty ratings are per ASTM C635

The suspension layout (main beam and cross tee spacing) will depend on the panel size being installed. Please refer to the appropriate section for the layout specific to your panel size. Contact TechLine for information on alternate grid layouts if it is required for changing the grain direction or integrating fixtures. Perimeter support and attachment options will change on non-seismic vs. seismic installations. Please refer to Section 5 for seismic perimeter attachment details.

3.2 Suspension System Layout

3.2.1. The suspension system for 2' x 2' panels must consist of main beams (Item 7501) spaced 48" O.C. The 48" cross tees (Item XL7549) must intersect the main beams at 90° every 24". The 24" cross tees (Item XL7520) must be installed at the midpoints of the 48" tees.

3.2.2. The suspension system for 1' x 4' panels must consist of main beams (Item 7501) installed at 48" O.C. 4' cross tees (Item XL7549) may be installed parallel or perpendicular to the main beams.

3.2.3. The suspension system for 1' x 6' panels must consist of main beams (Item 7501) at 2' O.C. 2' cross tees (Item XL7520) must intersect the main beam at 90° every 6' with 6' cross tee (Item XL7590) installing parallel to the main beam completing the assembly.

3.2.4. The suspension system for 2' x 4' and 2' x 6' panels must consist of main beams (Item 7501) installed at 2' O.C. with 2' cross tees (Item XL7520) installing at 90° every 48" (for 2' x 4') or 72" (for 2' x 6') completing the assembly.

3.2.5. In all cases, hangers must be spaced no more than 4' O.C. along the length of the main beams and should be located not more than 6" from a cross tee/main beam intersection.

4. INSTALLATION

4.1 Cutting the Panel

Cut the panel using standard woodworking tools and techniques. A table saw is recommended for straight cuts and a band saw for curved cuts. In both cases, panels should be cut face up to minimize chipping of the face veneer. Fine-toothed blades recommended for finish cuts will yield the best results.

4.2 Cutting the Border Panel

A router can be used to cut a tegular edge on border panels, or a straight cutoff is possible if border clips are used to support the cut edge of perimeter panels. One (1) border clip is required for each foot of panel edge (i.e., one (1) clip for edges up to 12" long and two (2) clips for edges greater than 12" up to 24"). Clips and screws are included with the panels.

CAUTION! WOOD DUST. Sawing, sanding, and machining wood products can produce dust. Airborne wood dust can cause respiratory, eye, and skin irritation. The International Agency for Research on Cancer (IARC) has classified wood dust as a nasal carcinogen in humans.

Precautionary measures: If power tools are used, they should be equipped with a dust collector. If high dust levels are encountered, use an appropriate NIOSH-designed dust mask. Avoid dust contact with eyes and skin.

First Aid Measure in case of irritation: Flush eyes or skin with water for at least 15 minutes.

4.3 Attach Border Clips

Apply WoodWorks® Tegular border clips to the cut edge of the panel as shown (Fig 1). Use one #8 × 9/16" screw in each clip.

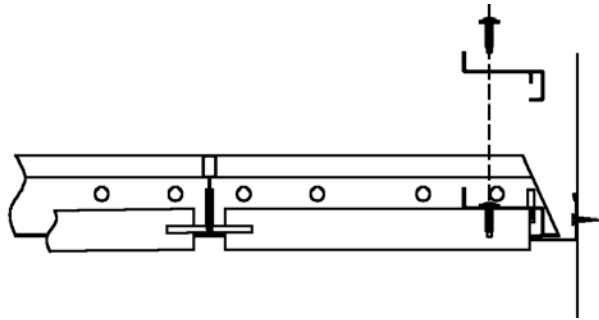

(Fig 1)

4.4 Odd Size Panels

Special size panels are available to accommodate less than full modules within the field of the ceiling. A second option would be to field cut these panels to the correct dimension. Examples of conditions that might require this procedure would be odd-sized panels next to a linear air diffuser or 1' x 4' light fixtures.

4.5 Attach Safety Cables for 2' x 4' and 2' x 6' Panels

2' x 4' and 2' x 6' panels weigh in excess of 20 pounds and, therefore, must have safety cables attached to prevent them from falling to the floor in the event of a grid failure. The safety cables will consist of an 18" length of wire rope with a small loop formed at each end and a bag snap fitted to one of the loops. Two cables are required at diagonal corners of each panel as detailed in Fig 2.

4.5.1. Attach two 18" long sections of 1-1/2" drywall grid, near opposite corners, on the back of the panels. Use six (6) #8 × 9/16" long framing screws to secure each piece of grid. Be careful not to strip out the holes when screwing. Cinch the plain end of the cable around the hanger wire closest to the corner of the panel and connect the bag snap to a hanger wire hole on the grid section.

4.5.2. Attach Grid Stabilizer Clips to 1' x 6' and 2' x 6' Panels

Attach two (2) grid stabilizer clips to the long side of each panel. Clips should be offset to clips of adjacent panels. See below (Fig 2).

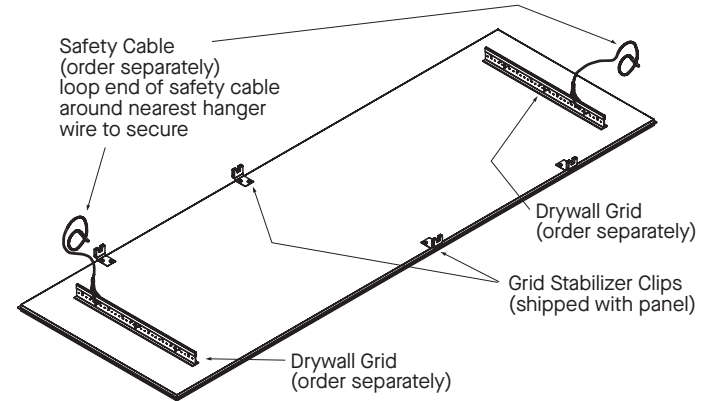

(Fig 2)

4.6 Treating Exposed Edges

Cut panel edges that are exposed to view will have to be treated to look like factory edges. Prefinished peel-and-stick edgebanding is available for this purpose. Cut edge must be clean and smooth before applying edgebanding. Peel off the release paper (edgebanding and trimming tools are ordered directly from Armstrong through the Customer Focus Center) and apply the edgebanding using finger pressure or a small trim roller. Apply a thin layer of wood glue to the edgebanding to ensure it creates a solid bond to the panel. Trim excess material with a sharp knife blade or with the edge trimmer available for order through Armstrong.

4.7 Edgebanding

Prefinished pressure-sensitive adhesive banding is available 15/16" wide and in 25' lengths.

5. SEISMIC INSTALLATION (C AND D, E, F)

WoodWorks Tegular and WoodWorks® TechZone® panels have been engineered for application in seismic areas. This system has been successfully tested in applications simulation Seismic Design Categories D, E, and F. For more details on seismic installations please see our Seismic Design: What You Need To Know brochure.

5.1 General

The installation must, in all cases, conform to the requirements of the International Building Codes and its referenced standards. Because these panels weigh in excess of 2.5 LBS/SF, all seismic installations of this product must be installed following the additional requirements:

- ASTM C635 rated heavy-duty 9/16" T-Bar suspension system
- Stabilizer bars are required on all perimeter edges unless some other means is provided to prevent spreading (such as fixed mechanical attachments to the perimeter, i.e. BERC2 clips)
- Walls or soffits that serve to support a panel edge must be braced to structure so as not to allow movement greater than 1/8" when subjected to design lateral force loads. When such bracing is not practical or is not effective, additional mechanically connected suspension system components must be provided to capture the edges of every panel. Axiom® Perimeter Trim connected to the suspension system with AXTBC clips will also meet this requirement.

The requirements listed here represent the manufacturer's minimum acceptable installation recommendations, and may be subject to additional requirements established by the local authority having jurisdiction.

5.2 Suspension System Layout

Reference Section 3.2 in this document (Suspension System Layout) for the suspension components and system layout. The following are the additional components required in addition to what's detailed in Section 3.2.

Attached and Unattached Walls: All grid connections to the wall are required to use the BERC2 to meet the attached and unattached wall requirements (**Figs 3 & 4**).

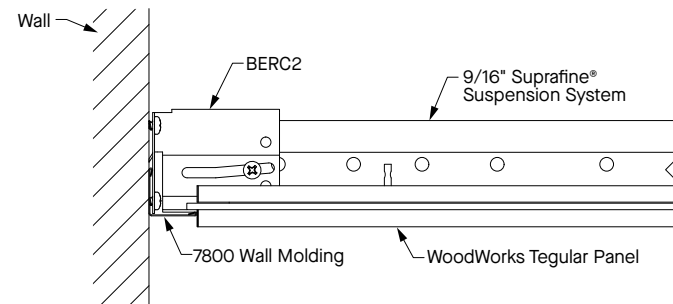

(Fig 3)

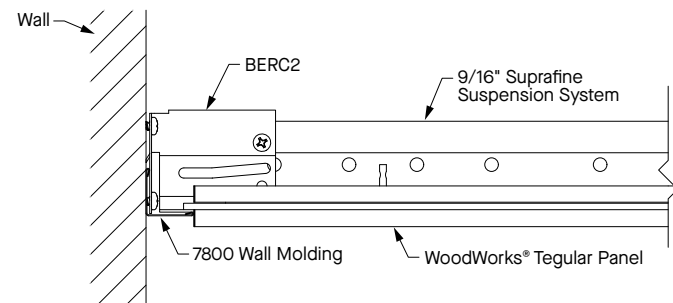

(Fig 4)

Seismic Rx® Suspension System Category C, D, E, & F

- The installation must conform to basic minimums established in ASTM C636
- Minimum 7/8" wall molding
- Suspension system must be attached on two adjacent walls
- The opposite pair of adjacent walls require BERC2 with 3/4" clearance
- BERC2 maintains main beam and cross tee spacing; no other components required
- Heavy-duty systems as identified in ICC-ESR-1308
- Safety wires required on light fixtures
- Perimeter support wires within 8"
- Ceiling areas over 1,000 SF must have horizontal restraint wire or rigid bracing
- Ceiling areas over 2,500 SF must have seismic separation joints or full-height partitions

- Ceilings without rigid bracing must have 2" oversized trim rings for sprinklers and other penetrations
- Changes in ceiling plane must have positive bracing
- Cable trays and electrical conduits must be independently supported and braced
- Suspended ceilings will be subject to special inspection
- Suspension layouts are the same as described in Section 4: Suspension System. Alternate grid layouts (cross-hatched) are not recommended
- Connection to wall – See BPCS-4141 Seismic Design: What You Need to Know – Code Requirements Seismic Rx® Suspension System Solutions – Seismic Rx Suspension System Approaches To Category C and D, E, and F Installations
- Special bracing required – See BPCS-4141 Seismic Design: What You Need to Know – Code Requirements Seismic Rx Suspension System Solutions – Bracing and Restraint for Seismic Installation

Item No. ♦	Description	Ordered Separately/ Included with	Required for Install	Sold by the	PCS/CTN
WOODWORKS® TEGULAR PANELS					
5404F01_ _ _ _ _	24 × 24 × 3/4" Panel	Ordered Separately	Based on Design	64 SF Min.	Bulk
6484F01_ _ _ _ _	12 × 48 × 3/4" Panel	Ordered Separately	Based on Design	64 SF Min.	Bulk
6485F01_ _ _ _ _	12 × 72 × 3/4" Panel	Ordered Separately	Based on Design	64 SF Min.	Bulk
6486F01_ _ _ _ _	24 × 48 × 3/4" Panel	Ordered Separately	Based on Design	64 SF Min.	Bulk
6487F01_ _ _ _ _	24 × 72 × 3/4" Panel	Ordered Separately	Based on Design	64 SF Min.	Bulk
WOODWORKS® TECHZONE® PANELS					
6510F01_ _ _ _ _	24 × 42 × 3/4" Panel	Ordered Separately	Based on Design	64 SF Min.	Bulk
6511F01_ _ _ _ _	30 × 30 × 3/4" Panel	Ordered Separately	Based on Design	64 SF Min.	Bulk
6512F01_ _ _ _ _	27 × 30 × 3/4" Panel	Ordered Separately	Based on Design	64 SF Min.	Bulk
FSC® CERTIFIED WOODWORKS TEGULAR PANELS					
5404F02_ _ _ _ _	24 × 24 × 3/4" Panel	Ordered Separately	Based on Design	64 SF Min.	Bulk
6484F02_ _ _ _ _	12 × 48 × 3/4" Panel	Ordered Separately	Based on Design	64 SF Min.	Bulk
6485F02_ _ _ _ _	12 × 72 × 3/4" Panel	Ordered Separately	Based on Design	64 SF Min.	Bulk
6486F02_ _ _ _ _	24 × 48 × 3/4" Panel	Ordered Separately	Based on Design	64 SF Min.	Bulk
6487F02_ _ _ _ _	24 × 72 × 3/4" Panel	Ordered Separately	Based on Design	64 SF Min.	Bulk
FSC-CERTIFIED WOODWORKS TECHZONE PANELS					
6510F02_ _ _ _ _	24 × 42 × 3/4" Panel	Ordered Separately	Based on Design	64 SF Min.	Bulk
6511F02_ _ _ _ _	30 × 30 × 3/4" Panel	Ordered Separately	Based on Design	64 SF Min.	Bulk
6512F02_ _ _ _ _	27 × 30 × 3/4" Panel	Ordered Separately	Based on Design	64 SF Min.	Bulk
SUSPENSION SYSTEM COMPONENTS					
7501	Suprafine® HD Main Runner	No	Yes	CTN	20
XL7549	Suprafine HDE 4' Cross Tee	No	Based on Design	CTN	60
XL7590	Suprafine HDE 6' Cross Tee	No	Based on Design	CTN	60
XL7520	Suprafine 2' Cross Tee	No	Based on Design	CTN	60
7800	7/8" Angle Molding	No	Yes (Wall-to-Wall)	CTN	30
ACCESSORIES					
7425, 7455	24" and 48" Stabilizer Bars	No	Yes*	CTN	1000
BERC2	2" Beam End Retaining Clip	No	Required	CTN	200/50
6408_ _ _	3/4" Edgebanding	No	No	1 roll	25 FT
6091	Safety Cable	No	Yes**	CTN	50
-	Border Clips	Yes	Yes – Cut Perimeter Panels	-	-

♦ When specifying or ordering, include the appropriate 2-digit perforation and 3-letter veneer suffixes

*Stabilizer bars are required if grid is not attached to perimeter with BERC2

**2' x 4' and 2' x 6' panels weigh in excess of 20 pounds and therefore must have safety cables.

MORE INFORMATION

For more information, or for an Armstrong Ceilings representative, call 877 276-7876.

For complete technical information, detail drawings, CAD design assistance, installation information, and many other technical services, call TechLine customer support at 877 276-7876 or FAX 800 572-TECH.

FSC® is a registered trademark of Forest Stewardship Council®, A.C., license code FSC-C007626

All other trademarks used herein are the property of AWI Licensing LLC and/or its affiliates.

© 2023 AWI Licensing Company Printed in the United States of America

BPLA-295694-1023



Armstrong®
World Industries