



**TECHNICAL GUIDE**



**HANGING  
& FRAMING  
CURVED CEILINGS**

**DRYWALL GRID SYSTEM**  
**FRAMEALL™**



**Armstrong®**  
World Industries

# AHEAD OF THE CURVE

## FRAMEALL™ DRYWALL GRID

FrameAll™ Drywall Grid offers a worry-free approach to incorporating hills, valleys, undulating waves, vaults, and domes into your design. Combining our faceted main beam with our RC2 clip allows you to:

- Create custom radii to suit any design
- Have ultimate control of the curve
- Expand your design beyond traditional pre-selected or pre-determined radii



Flat Drywall Grid barrel vault installation

## TABLE OF CONTENTS

- 2 Code Compliance
- 2-3 Performance
- 4-5 Components & Moldings
- 6-7 Axiom® Trim
- 8-9 Accessories
- 10 Curved Main Beams
- 11-12 Creating a Template
- 13-15 Vaults
- 16-20 Domes
- 21 Finishing and Exterior Application
- 22 Radius in Feet
- 23 Estimating Materials

## CODE COMPLIANCE YOU CAN TRUST

- Meets:
- ASTM C1858
  - ASTM C635
  - ASTM C645
  - ASTM C754
  - ASTM C840
  - ASTM E3090
  - ASTM A653
  - ASTM A1003
  - ASTM C1925
  - City of LA – RR 25348
  - International Building Code, Continuous Membrane, One Level.
  - Per Section 25.210 single level drywall ceilings do not require lateral bracing when walls are more than 50 feet apart. When walls are more than 50 feet apart, the ceiling should be examined for bracing requirements
  - IBC categories D, E and F single layer drywall ceilings are exempt from lateral force bracing requirements, regardless of room size.
  - Consult local codes for specific requirements.



## PERFORMANCE (cont...)

- PeakForm® profile increases strength and stability for improved performance during installation
- XL® (staked-on end detail) cross tees provide secure locked connection; fast and easy to install
- SuperLock™ main beam clip is engineered for a strong, secure connection and fast accurate alignment confirmed with an audible click; easy to remove and relocate
-  Knurled Ridges on cross tees for speed of screw insertion during board installation

## (...cont.) PERFORMANCE

- ScrewStop™ reverse hem prevents screw spinoff on 1-1/2" wide face
- Faceted main beam – prenotched main beam to simplify assembly of curved sections; all notched locations along main beam require installation of RC2 clip HD8906F08 – Prenotched 8" O.C. HD8906F16 – Prenotched 16" O.C.
- Rotary-stitched – Greater torsional strength and stability
- 1-1/2" wide face main beams and cross tees – easy installation of screw applied gypsum wallboard
- G40 Hot dipped galvanized coating – corrosion resistance
- G90 Hot dipped galvanized coating – superior corrosion resistance for exterior applications (HD8906F08 and HD8906F16 not available in G90 coating)
- Cross tee spacing: 24" O.C. for 5/8" drywall 16" O.C. for 1/2" drywall 8" O.C. for tight radius

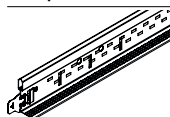
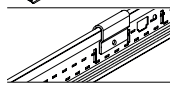
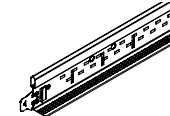
MAIN BEAMS

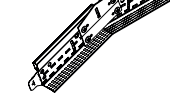
Perspective	Item No.	Length	Height	Pcs./Ctn	LF/Ctn	Load Test Data (Lbs/LF)					
						L/240 Simple Span			L/360 Simple Span		
						24"	36"	48"	24"	36"	48"
	HD8906 HD8906G90 HD8906HRC	144"	1-11/16"	12	144	120.0	48.95	28.14	95.5	43.19	18.66
	HD8906IIC	144"	1-11/16"	12	144	120.0	48.95	28.14	95.5	43.19	18.66
	HD890610	120"	1-11/16"	12	120	120	48.95	28.14	95.5	43.19	18.66
	HD8906F08*	144"	1-11/16"	12	144	-	-	18.4	-	-	12.3
	HD8906F16*	144"	1-11/16"	12	144	-	-	18.4	-	-	12.3

\*Tested flat per ASTM C635 with RC2 clips at each faceted location  
 Red Numbers are Fire Guard items. For fire-rated assemblies, use Type C gypsum board as noted in the UL® fire-rated assembly designs.

FACETED MAIN BEAM

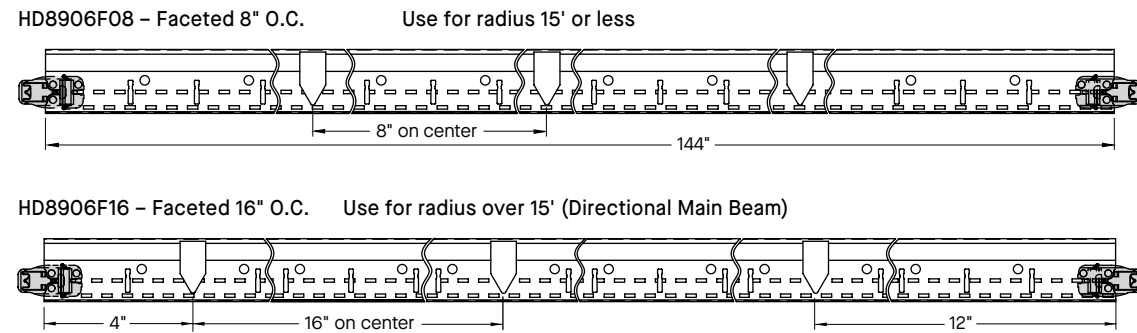

CROSS TEES

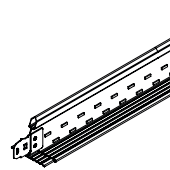
Perspective	Item No.	Length	Height	Pcs./Ctn	LF/ Ctn	Load Test Data (Lbs/LF)	
						L/240 Simple Span	L/360 Simple Span
						72"	72"
	XL8965 XL8965HRC XL8965G90	72"	1-1/2"	36	216	6.87 @ 72"	4.58 @ 72"
	XL8947P XL8947PG90	50"	1-1/2"	36	150	19.5 @ 50"	12.79 @ 50"
	XL8945P XL8945HRC XL8945PG90	48"	1-1/2"	36	144	22.5 @ 48"	14.27 @ 48"
	XL8940	40"	1-1/2"	36	119	36.22 @ 40"	24.15 @ 40"
	XL7936G90**	36"	1-1/2"	36	108	45.7 @ 36"	31.33 @ 36"
	XL8926 XL8926G90	24"	1-1/2"	36	78	119.0 @ 24"	90.25 @ 24"

CROSS TEES (...CONT.)

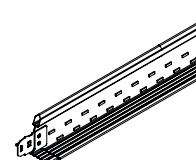
Metric	Perspective	Item No.	Length	Height	Pcs./Ctn	LF/ Ctn	Load Test Data (Lbs./LF)		Load Test Data (KG./LM)	
							L/240 Simple Span	L/360 Simple Span	L/240 Simple Span	L/360 Simple Span
								Drywall Cross Tees – Metric	XL7961*	1600mm
		XL7930*	1200mm	38mm	36	138.8	22.4 @ 48"	14.93 @ 48"	33.48 @ 1200mm	21.24 @ 1200mm
		XL7925*	900mm	38mm	36	108	51.92 @ 36"	34.61 @ 36"	68.01 @ 900 mm	46.62 @ 900mm
		XL7920*	600mm	38mm	36	69.4	114.59 @ 24"	79.39 @ 24"	177.15 @ 600mm	134.31 @ 600mm

Red Numbers are Fire Guard items. For fire-rated assemblies, use Type C gypsum board as noted in the UL® fire-rated assembly designs.  
 NOTE: All load test data based on flat installation per ASTM C635.  
 \*Indicates items that are not Type F Fixture compatible

MOLDINGS

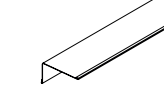
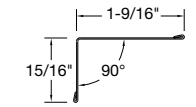
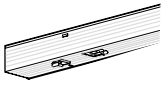
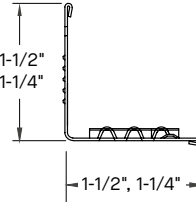
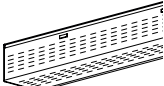
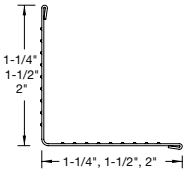
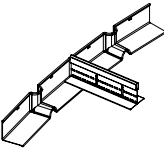
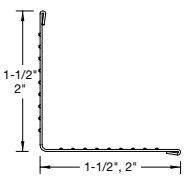
Perspective	Item No.	Length	Height	Metal Thickness	Pcs/Ctn	LF/Ctn	Profile	
	Reverse Angle Molding	7858	144"	15/16"	0.018"	20	240	
	Locking Angle Molding	LAM12	144"	1-1/4"	0.018"	10	240	
		LAM12G90	144"	1-1/4"	0.018"	10	240	
		LAM12HRC	144"	1-1/4"	0.018"	10	240	
		LAM151220E	144"	1-1/2"	0.028"	10	120	
	Knurled Angle Molding (KAM)	KAM10	120"	1-1/4"	0.018"	10	100	
		KAM12	144"	1-1/4"	0.018"	10	120	
		KAM12G90	144"	1-1/4"	0.018"	10	120	
		KAM1510	120"	1-1/2"	0.018"	10	100	
		KAM1512	144"	1-1/2"	0.018"	10	120	
		KAM151020E	120"	1-1/2"	0.028"	10	100	
		KAM151220E	144"	1-1/2"	0.028"	10	120	
		KAM151020	120"	1-1/2"	0.033"	10	100	
		KAM1525G90	120"	1-1/2"	0.018"	10	100	
		KAM1520G90	120"	1-1/2"	0.018"	10	100	
		KAM21025	144"	2"	0.018"	10	100	
		KAM21020EQ	120"	2"	0.028"	10	100	
		KAM21020	120"	2"	0.033"	10	100	
	SimpleCurve® KAM	SC151220EQ (37" Radius)	148"	1-1/2"	0.028"	10	124	
		SC151225 (32" Radius)	148"	1-1/2"	0.018"	10	124	
		SC21220EQ (55" Radius)	148"	2"	0.028"	10	124	
		SC21225 (40" Radius)	148"	2"	0.018"	10	124	

**AXIOM DRYWALL TRANSITIONS**

Material: Extruded aluminum, alloy 6063

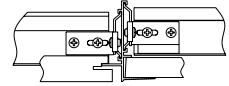
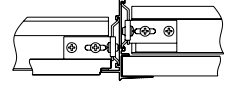
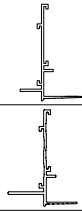
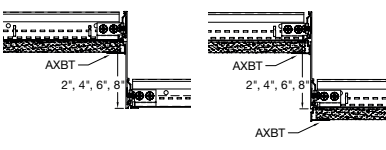
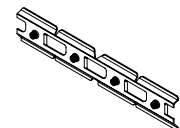
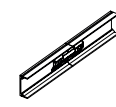
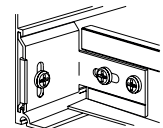
Item No.	Length/Item Description	Dimensions	
AXTRVSTR	Straight Transition for Axiom® Vector® Ceiling	120 × 2-9/16 × 1-11/16"	 Axiom® - Transitions with Vector® panel to drywall perimeter (AXTRVSTR)
AXTRTECUR	Curved Transition for Tegular	120 × 2-9/16 × 1-11/16"	 Axiom® - Transitions with Tegular panel to drywall perimeter (AXTRTESTR, AXTRTECUR)
AXTR7907STR	9/16" Tegular Transition Molding, Straight	120 × 2-9/16 × 1-11/16"	
AXTR7907CUR	9/16" Tegular Transition Molding, Curved	Vary x 2-9/16 × 1-11/16"	
AXTR7908STR	15/16" Tegular Transition Molding, Straight	120 × 2-9/16 × 1-13/16"	
AXTR7908CUR	15/16" Tegular Transition Molding, Curved	Vary x 2-9/16 × 1-13/16"	
AXTR2STR	2" Straight Transition	120 × 2 × 1-1/2"	 Acoustical-to-Drywall      Drywall-to-Drywall
AXTR2CUR	2" Curved Transition	120 × 2 × 1-1/2"	
AXTR4STR	4" Straight Transition	120 × 4 × 1-1/2"	
AXTR4CUR	4" Curved Transition	120 × 4 × 1-1/2"	
AXTR6STR	6" Straight Transition	120 × 6 × 1-1/2"	
AXTR6CUR	6" Curved Transition	120 × 6 × 1-1/2"	
AXTR8STR	8" Straight Transition	120 × 8 × 1-1/2"	
AXBTSTR AXBTCUR	Drywall Bottom Trim for Straight and Curved 5/8" Drywall	120 × 1-1/8 × 27/32"	
AXBTASTR AXBTACUR	Bottom Trim for AcoustiBuilt® Ceiling Systems (straight or curved)	-	
<b>ACCESSORIES</b>			
AX4SPICEB	Splice Plate	-	
AXSPICE2	Axiom Splice Plate Galvanized sheet steel formed to fit into the trim channel bosses. Provides positive lock between abutting channels with factory-installed setscrews.	-	
AXTBC	T-Bar Connector Clip	-	

**AXIOM ONE-PIECE DRYWALL TRIM**

Material: Commercial-quality extruded aluminum alloy 6063

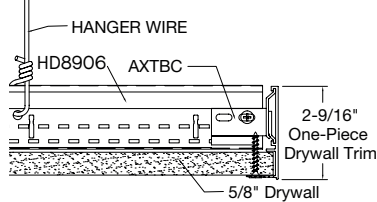
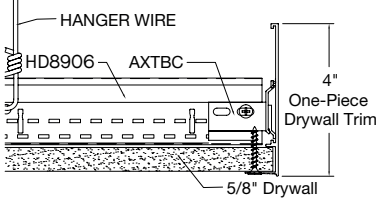
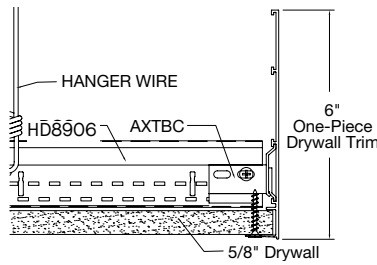
Item No.	Length/Item Description	
AX1PC2STR	2-9/16" One-Piece Straight Drywall Trim	 HANGER WIRE HD8906    AXTBC 2-9/16" One-Piece Drywall Trim 5/8" Drywall
AX1PC2CUR	2-9/16" One-Piece Curved Drywall Trim	
AX1PC4STR	4" One-Piece Straight Drywall Trim	 HANGER WIRE HD8906    AXTBC 4" One-Piece Drywall Trim 5/8" Drywall
AX1PC4CUR	4" One-Piece Curved Drywall Trim	
AX1PC6STR	6" One-Piece Straight Drywall Trim	 HANGER WIRE HD8906    AXTBC 6" One-Piece Drywall Trim 5/8" Drywall
AX1PC6CUR	6" One-Piece Curved Drywall Trim	

NOTE: For use with 5/8" drywall only

**DRYWALL GRID ACCESSORIES**

**DRYWALL GRID ACCESSORIES**

A variety of drywall grid accessories are available to provide problem-solving solutions that save time, labor, and money. For a complete list of accessories, request submittal BPCS-3082.

Item No.	Quantity	Description	Perspective	Application
DWACS	100	Drywall Attachment Clip facilitates transition from drywall to acoustical ceiling; locks under bulb of grid section to prevent upward movement and provide secure attachment surface on one side of exposed grid.		
FZDWACS	50			
DW30C	250	30-, 45-, 60-, and 90-degree Drywall Angle Clips are used to create positive and secure angles for drywall and ceiling installations on either main beams or cross tees.		
DW45C	250			
DW60C	250			
DW90C	250			
FZDW30C	50			
FZDW45C	50			
FZDW60C	50			
DW58LT	125	DW58LT – Transition Clip for 5/8" Drywall with Locking Tabs; facilitates transition from drywall to acoustical ceiling; one-sided hold down clip; eliminates need for drywall bead. Locking tabs provide secure location for Drywall Grid System tees.		
FZDW58LT	50			
DW50LT	125	DW50LT – Transition Clip for 1/2" Drywall with Locking Tabs; facilitates transition from drywall to acoustical ceiling; one-sided hold down clip; eliminates the need for a drywall bead. Locking tabs provide secure location for Drywall Grid System tees.		
FZDW50LT	50			
IIC	36	Impact Isolation Clip (IIC) for use with HD8906IIC drywall grid main beam. Provides up to 8 points of IIC improvement to ensure your project meets IBC requirements.  IIC2 for use with HD8906IIC drywall grid main beam. For conditions requiring two layers of drywall. Clip Color: Green IIC Clip must be used with HD8906IIC Drywall Grid Main Beam		
IIC2	36			
MBSC2	200	Main Beam Spacer Clip (2" in length) is used to space two parallel main beams 2" O.C. for air supply or return.		
GSC9	100	Adjustable Grid Spacer Clip is used to space two parallel main beams for light fixtures, air diffusers, etc.; allows for 1/4" adjustments with three different clips.		
GSC12	100			
GSC16	100			
FZGSC9	50			
FZGSC12	50			
RC2AG	205	RC2 – Radius Clip is used for drywall applications which form curved installations; attaches to the cavity side of web of the main beam with four 7/16" pan head screws. Install at all knockout locations.		
FZRC2AG	50			
RC1	200	RC1 – Splice Clip is used as a main beam splice or partition top trim splice.		
FZRC1	50			

Item No.	Quantity	Description	Perspective	Application
XTAC	100	Cross Tee Adapter Clip – is used to attach field cut cross tees to main beams.		
FZXTAC	50			
DDC	250	Double Drywall Clip to hang suspension system below existing 1-1/2" grid face, transferring weight directly to hanger wire; may be used to preserve the fire rating of an existing ceiling and to support heavy accessories; allows for double layer of 5/8" gypsum board.		
FZDDC	50			
DLCC	250	Direct Load Ceiling Clip to hang suspension system below existing 15/16" grid face, transferring weight directly to hanger wire; may be used to preserve the fire rating of an existing ceiling and to support heavy accessories.		
FZDLCC	50			
DWC	250	Drywall Clip allows for a "second" ceiling to be installed below a drywall ceiling; attach through installed drywall to supporting structure.		
MBAC	70	Main Beam Adapter Clip attaches to web of suspension system section; provides larger surface for screw attachments; used as a hold down clip for thin material (metal or plastic lay-in panels); fastens drywall track to underside of exposed suspension system with lay-in panels, leaving suspension system face free of screw holes.		
FZMBAC	50			
CBS4SS	50	4", 6", 8", 10", and 12" CBS Hangers – Channel Beam Support Hanger for SimpleSoffit™ is used for easier C Channel installations (New York City market only).		
CBS6SS	50			
CBS8SS	50			
CBS10SS	50			
CBS12SS	50			
CBS4A	200	4", 6", 8", 10", and 12" Channel Beam Splice – Used to suspend main beams to 1-1/2" black iron carrying channels CBS2004A (4"), CBS2006A (6"), and CBS2008A (8") used for 2" black iron carrying channels		
CBS6A	200			
CBS8A	200			
CBS10A	150			
CBS12A	150			
CBS2004A	75			
CBS2006A	75			
CBS2008A	75			

**XAL LED Light Drywall Trim Kit**

Item No.	Description	Fixture Length
<b>DRYWALL LINEAR LIGHTING</b>		
DGSLTK24	24" Linear Light Trim Kit	24" x 4"
DGSLTK30	30" Linear Light Trim Kit	30" x 4"
DGSLTK48	48" Linear Light Trim Kit	48" x 4"
DGSLTK60	60" Linear Light Trim Kit	60" x 4"
DGSLTK72	72" Linear Light Trim Kit	72" x 4"
DGSLTK90	90" Linear Light Trim Kit	90" x 4"
DGSLTK96	96" Linear Light Trim Kit	96" x 4"
DGSLTK120	120" Linear Light Trim Kit	120" x 4"
DGSLTKCON	120" Continuous Linear Light Trim Kit	120"

NOTE: Linear Light Trim Kits designed to work with 5/8" drywall

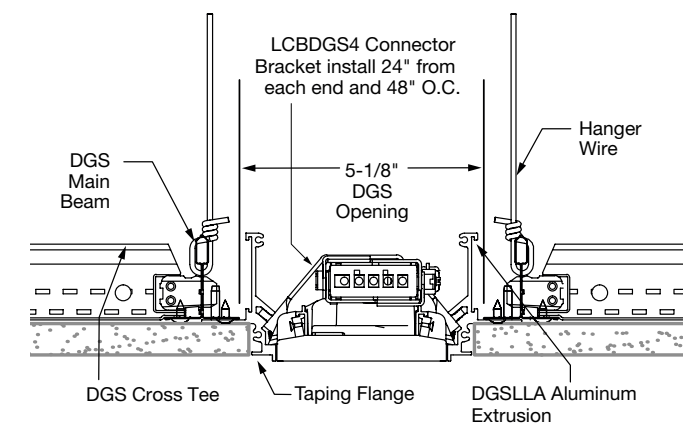

CREATING CURVES

- Creating curved framing for drywall is easy and offers unlimited possibilities.
- Custom radii to suit any design installation.
- You control the curve.
- Not limited to a pre-selected or pre-determined curved radius.
- Full range of clips and accessories make installation easier than bending stud and track.

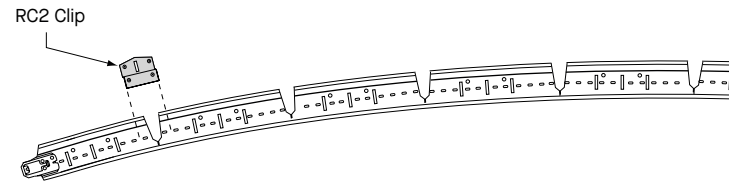

Radius and drywall thickness will determine on-center spacing of cuts. Refer to "Establishing An Arc" on page 9 for creating a curved template.

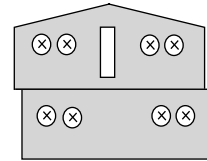

Install RC2 clip using four screws per clips.

RC2 Clip is used to secure the main beam at the desired angle in curved ceiling with rout for installing cross tees. Refer to "Making a Template" on page 9.

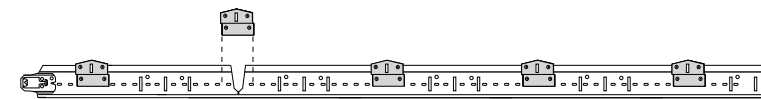

RC2 Clip must be installed at all knockout locations when used to frame a flat or curved ceiling.

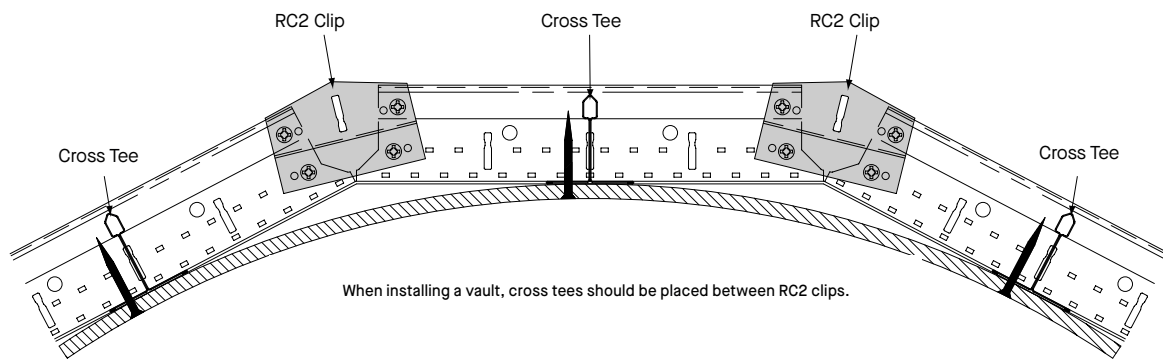

When installing a vault, cross tees should be placed between RC2 clips.

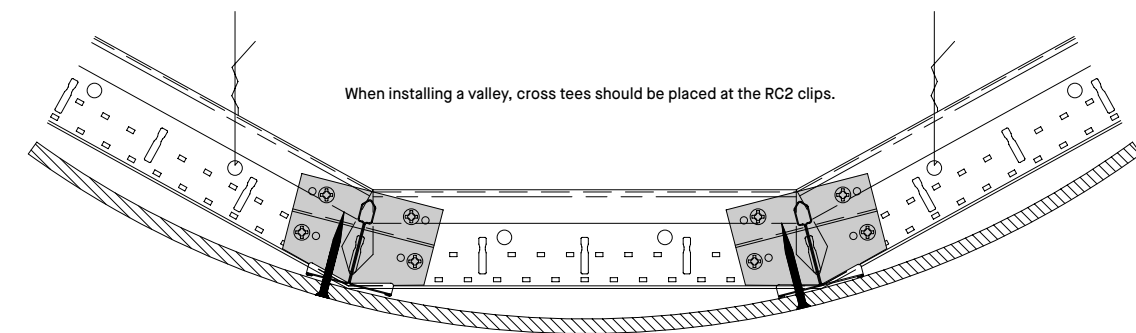

When installing a valley, cross tees should be placed at the RC2 clips.

ESTABLISHING AN ARC

How to draw a radius on a template (plywood, gypsum board, etc.)

- 1 Establish a center line.
- 2 Mark 2' increments on line perpendicular to center line.
- 3 At 2' marks, identify points of arc below perpendicular line (maintain consistent spacing of point). See radius charts on page 20.
- 4 Connect points to form a smooth arc.

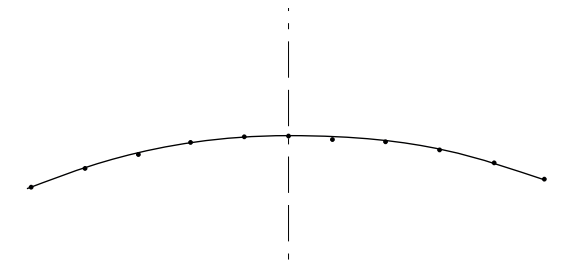
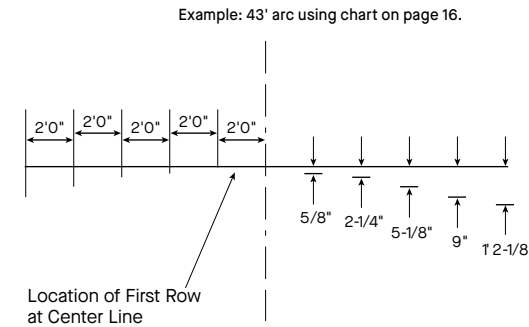

COMPLETING THE TEMPLATE - OPTION 1

- 1 Cut along the arc and remove section of template
- 2 Cut main beam as required and position along the cut radius on the template (use the chart on page 20).
- 3 Screw RC2 clips to faceted main beam at all knockout locations.\*
- 4 On the template, mark a rout location reference point to maintain consistent rout location.

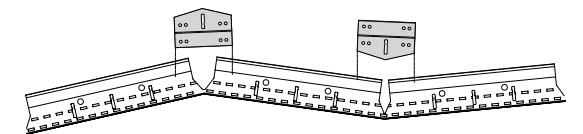
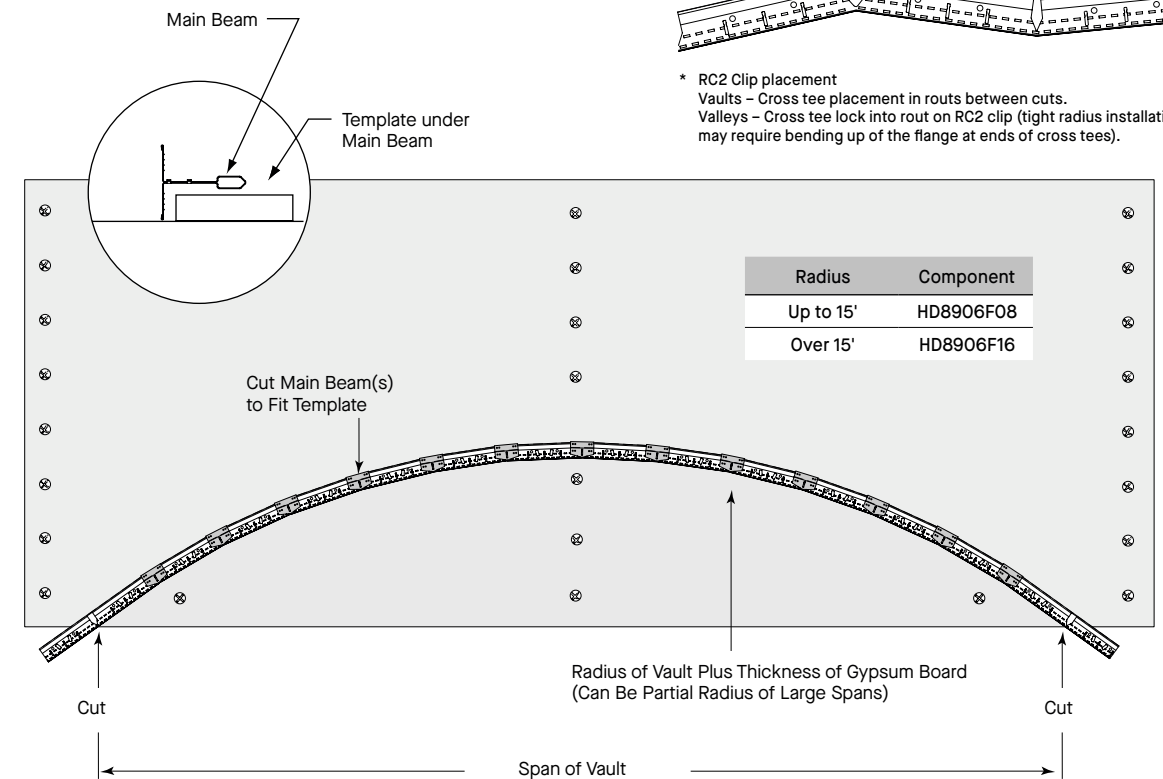

\* RC2 Clip placement  
Vaults - Cross tee placement in routs between cuts.  
Valleys - Cross tee lock into rout on RC2 clip (tight radius installations may require bending up of the flange at ends of cross tees).

COMPLETING THE TEMPLATE - OPTION 2

WORKING WITH VAULTS

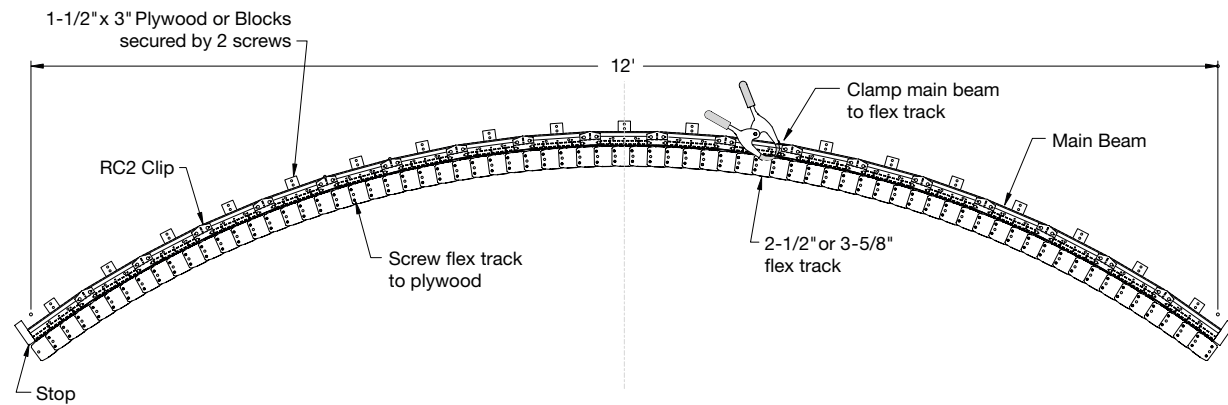

- 1 Draw radius on board.
- 2 Screw flex track to board along radius line.
- 3 Cut main beams as required and position along the flex track on the template.
- 4 Screw RC2 clips to faceted main beam at all knockout locations.
- 5 On the template, mark a rout location reference point to maintain consistent rout location.

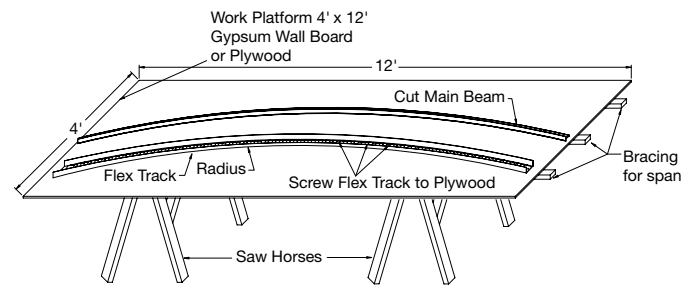

- Contractors' efficiency and understanding of the suspended grid system construction provides performance benefits and cost savings.
- An unlimited range of vaults and valleys can be constructed using faceted main beams made on the job to meet design needs.
- Single and multiple curved ceilings can be framed quickly and easily.

- 1 Hanger wires must be minimum 12 gauge and spaced along the main beams not more than 4' O.C. for gypsum board construction and not more than 3' O.C. for plaster work (spaced as required to support load).
- 2 Add vertical braces as required to stabilize the frame.
- 3 Thickness of the sheeting material is determined by its plasticity. Refer to table titled "Drywall Bending Radius" on page 19.
- 4 For vaults, space the main beams 4' O.C. for gypsum board construction and 3' O.C. for plaster. Angle or channel molding is used to frame the ends of the structure.

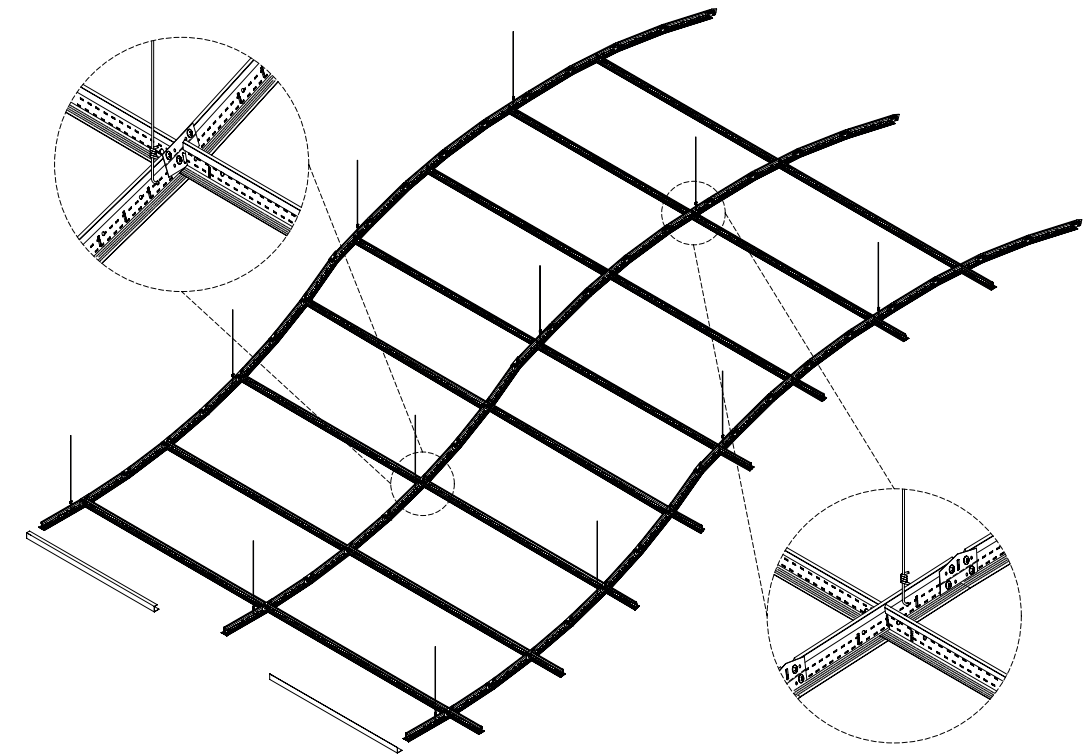

BARREL VAULT

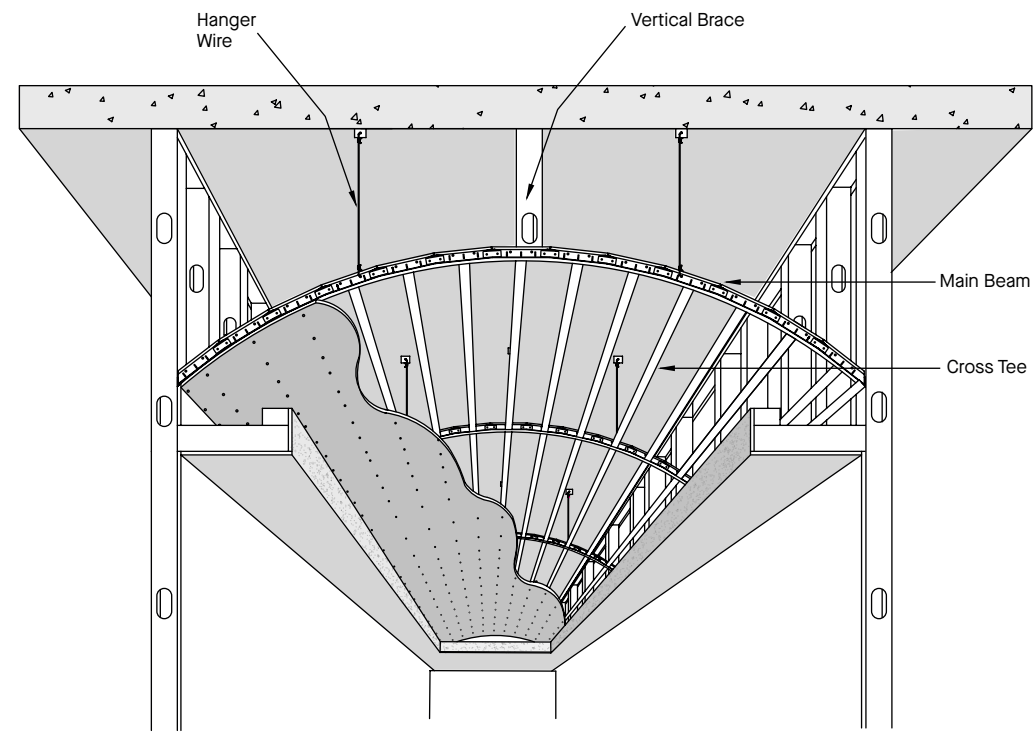

DOUBLE BARREL VAULT

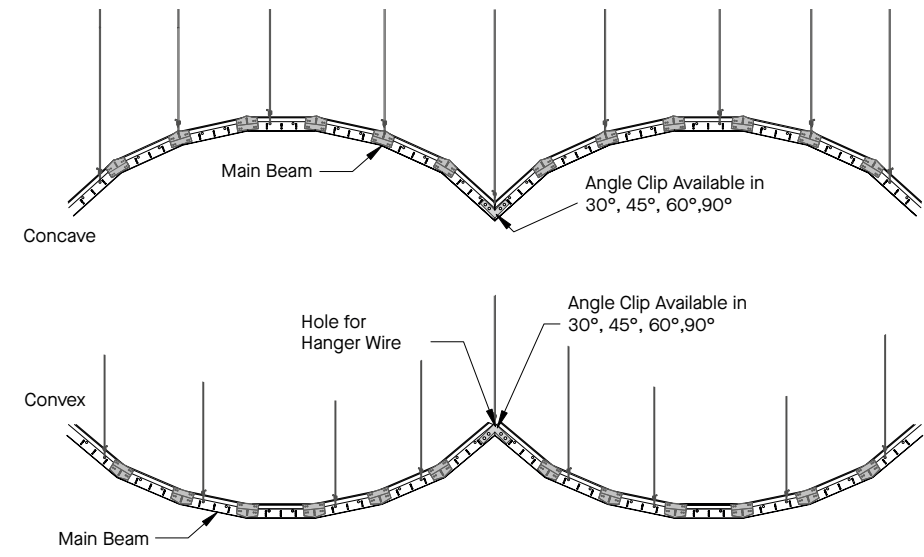

VAULT WITH PERIMETER LIGHT COVE

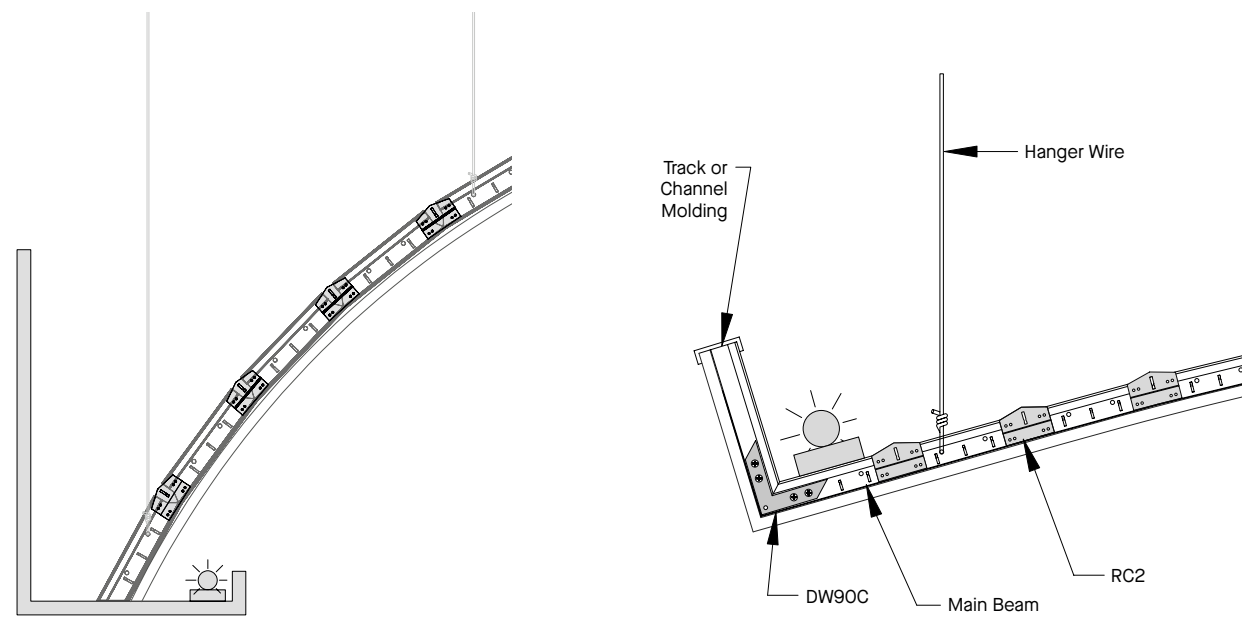

CEILING CLOUD

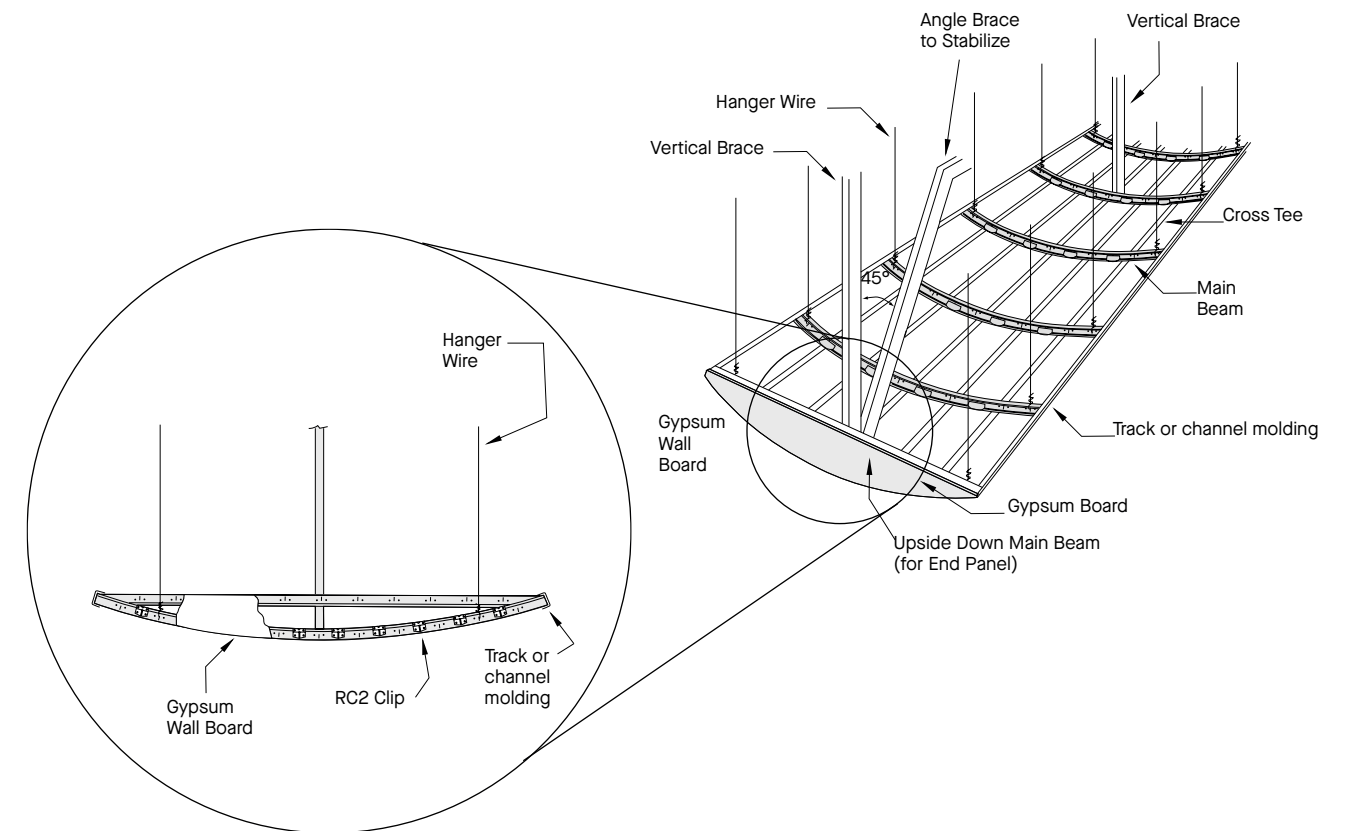



## WORKING WITH DOMES

Domes, like arches, have many variable characteristics that make each design unique. With a suspended drywall grid system, you can easily create the desired look of domes ranging from simple to complex.

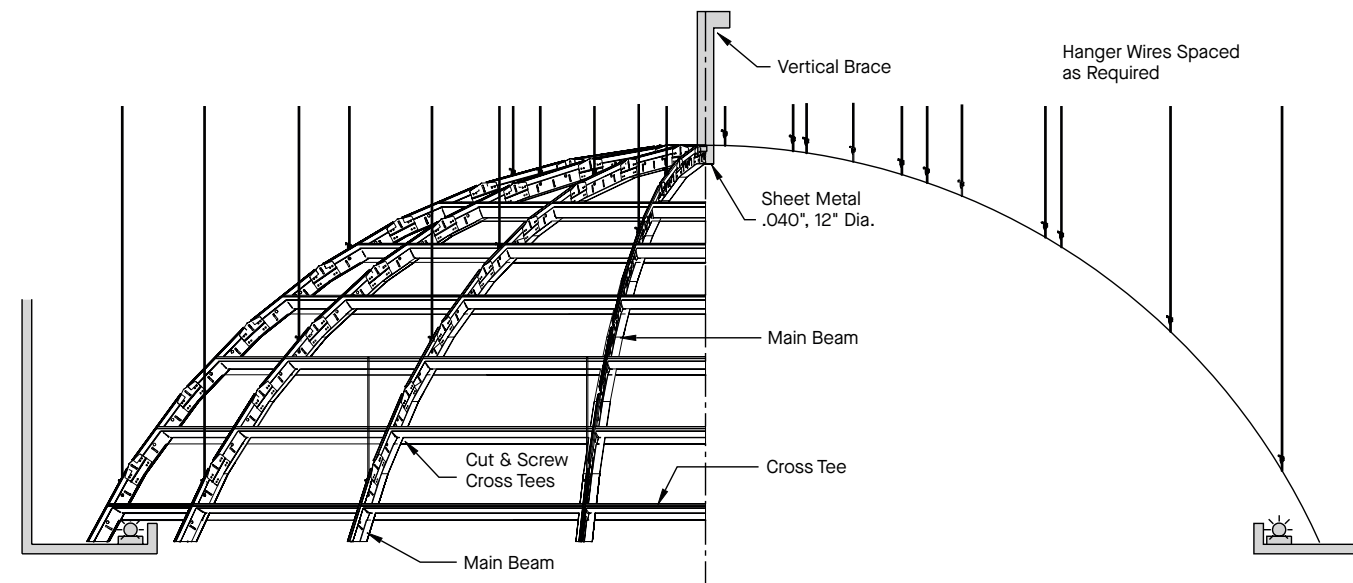

- 1 Determine the starting point at the top and bottom of the dome.
- 2 Prepare a sheet metal disk or donut for the top of the dome. The disk should be one to two feet in diameter and should be fabricated from steel with a thickness of at least 25-gauge thickness. Note that the center of the dome may need to be open to receive an electrical box, pole, or some other architectural detail. Refer to "Options for Top of Dome" on page 17.
- 3 Prepare a ring for the base of the dome from rolled angle or channel.
- 4 Attach curved main beams to the disk at the top of the dome and to the ring at the bottom with sharp point pan or wafer head screw (by others).
- 5 Mains should be spaced no greater than 4' O.C. (measured at the bottom ring). Install main beams 2' O.C. for a radius of 15' or less. (Refer to Radius Chart on page 22.)
- 6 Use cross tees cut to the appropriate length and screwed to the flange of the main beams to complete the dome frame structure.
- 7 Cross tees are not required near the top of the dome when the space between mains becomes less than 16".
- 8 The sheathing must be cut into pie shaped sections and screw attached to the framework.

## OPTIONS FOR TOP OF DOME

Vertical Brace

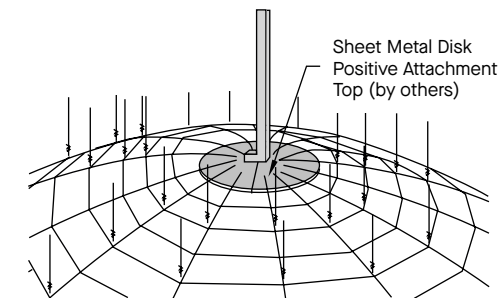

Light Fixture

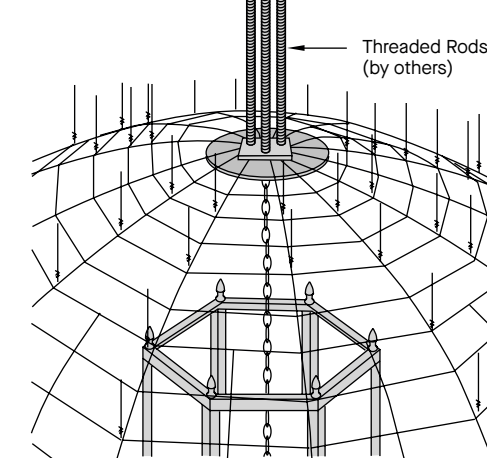

Folded Plate Dome

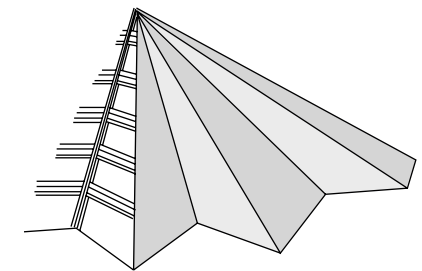

Cone

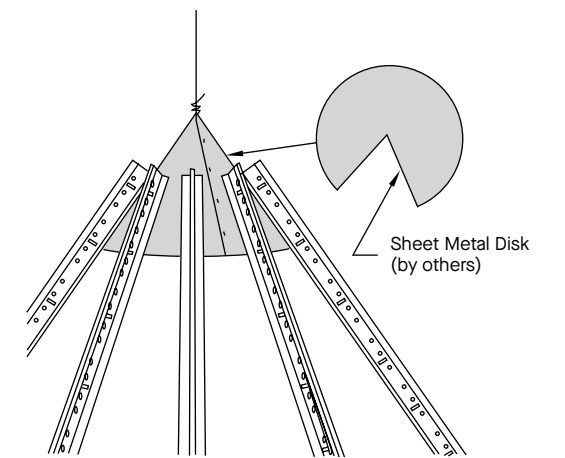

DOME COMPONENTS

Electrical Chain

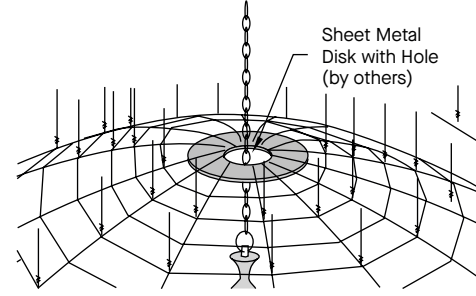

Electrical Box

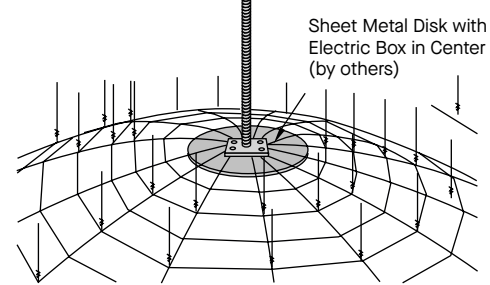

Self Supporting Tee Top

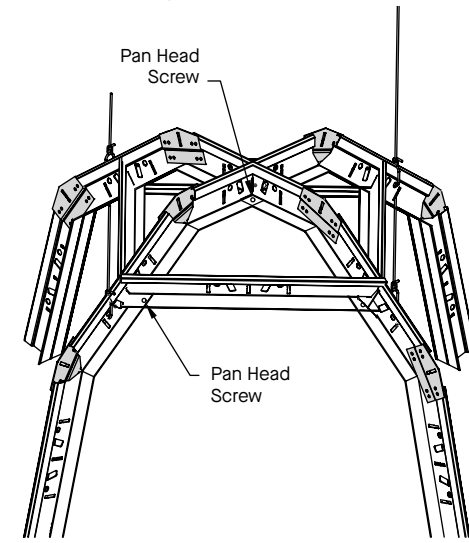

Dome with Skylight

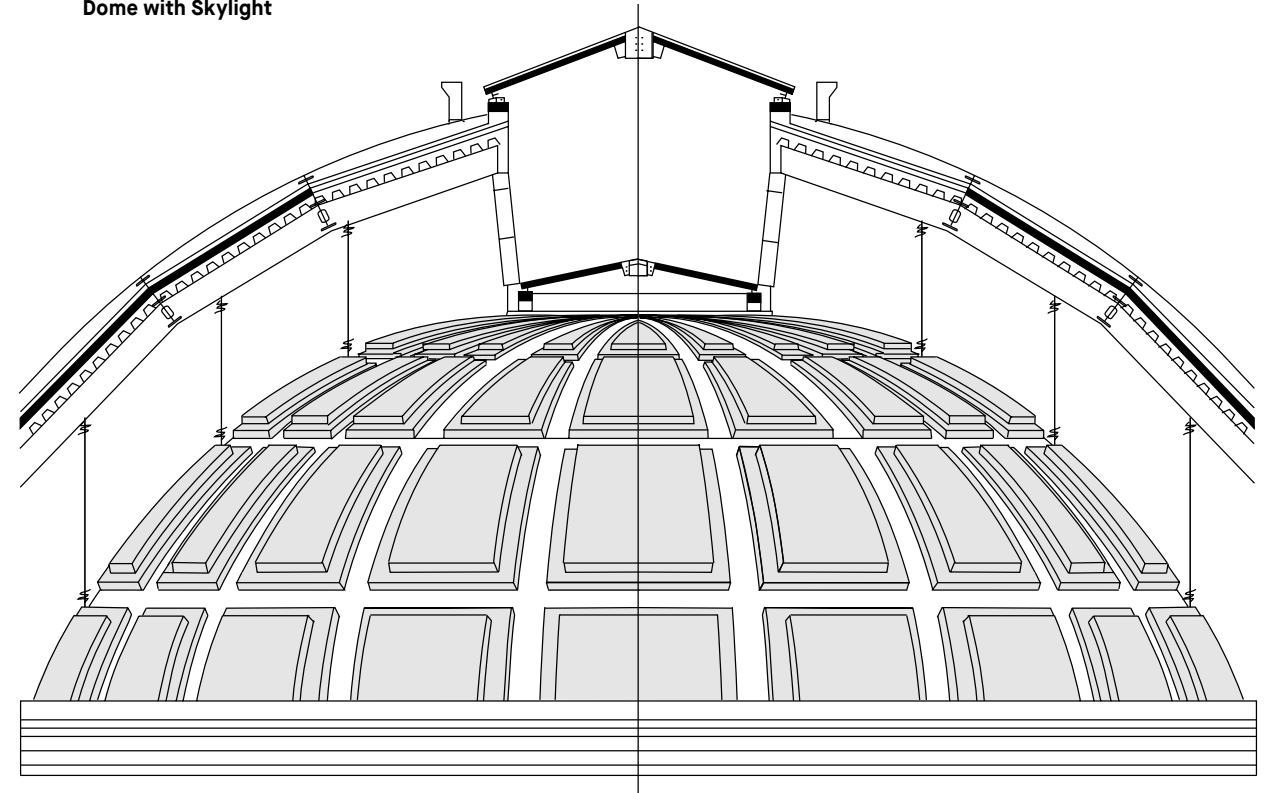

ADDITIONAL DOME TYPES

Typical Details

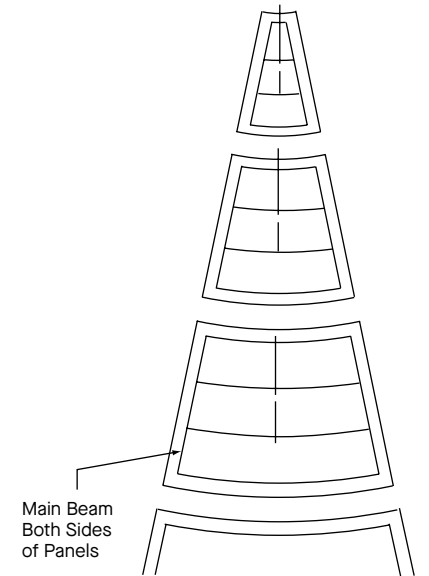
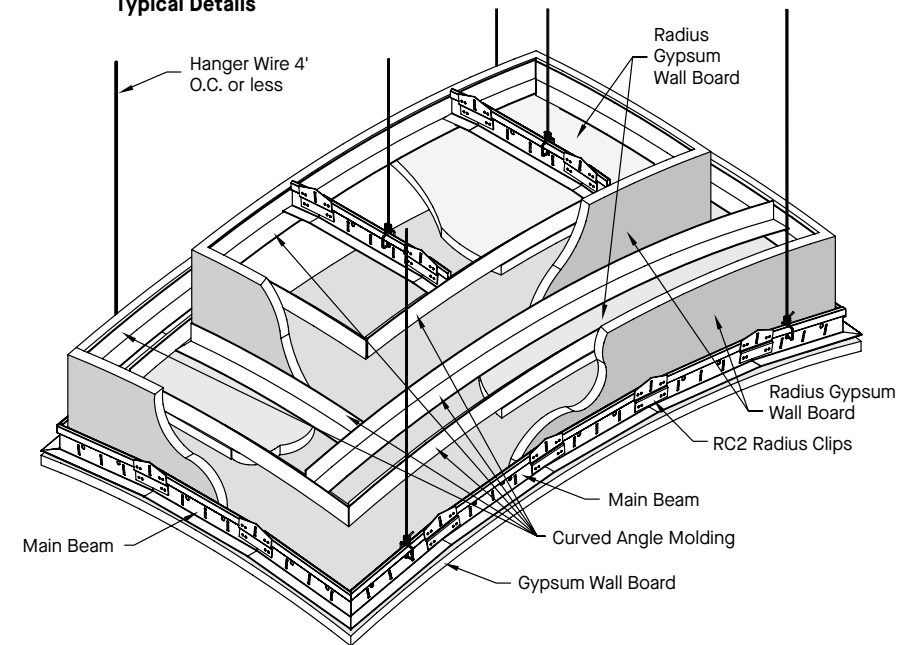

See page 15 for Bending Radius of gypsum board.

ADDITIONAL DOME TYPES

DRYWALL BENDING RADIUS

Multi-Level Dome

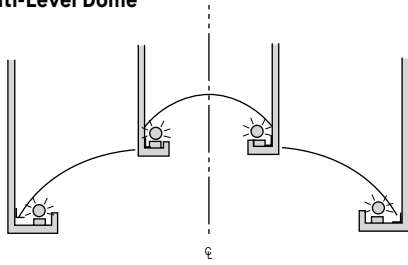

Egg or Elliptical Dome

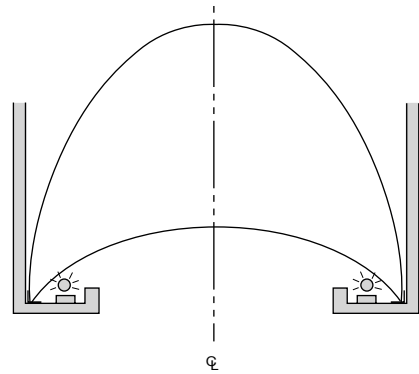

Saucer Dome Up

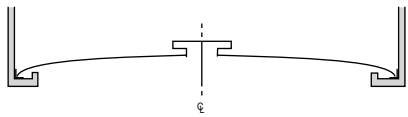

Saucer Dome Down

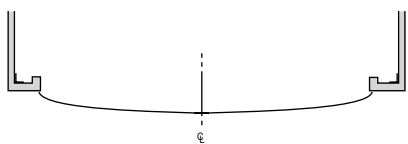

Saucer Dome

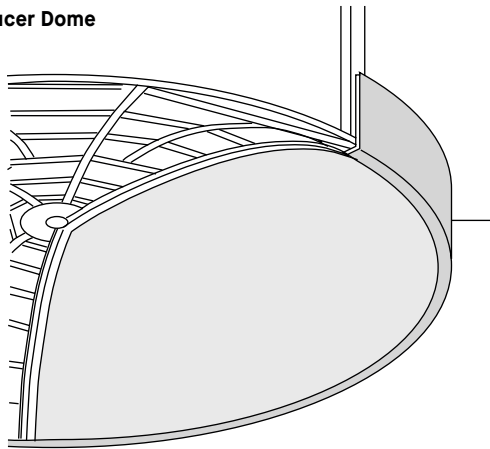

Pole Dome

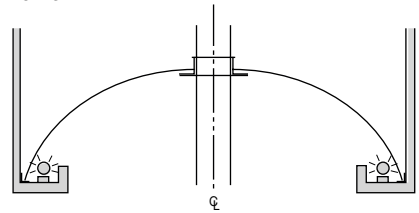

Step Up Dome

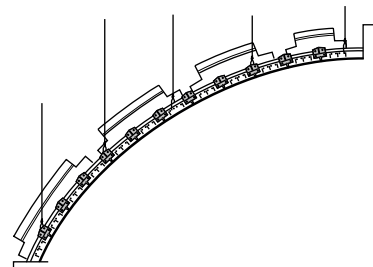

Checker Board Dome (step down)

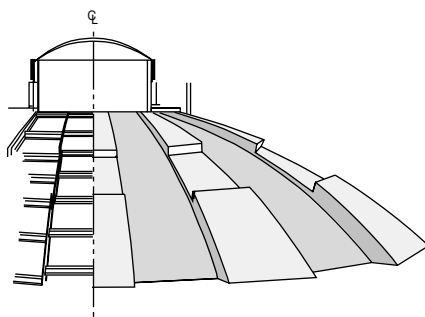

Offset 2 way Radius Dome  
Column Ring Made from a Metal Angle

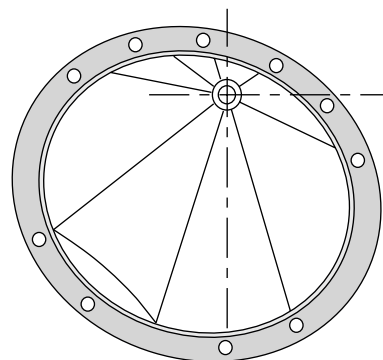

Material	Minimum Radius (dry)	Drywall Bending Radii		Water Required Per Panel (oz.)	
		Maximum Cross Tee Spacing (dry)	Minimum Radius (wet)		Maximum Cross Tee Spacing (wet)
1/4" Hi-flex Gypsum	32"	9"	20" concave 14" convex	8" concave 6" convex	-
1/4" Gypsum	5'	8"	2'	6"	30 ounces
3/8" Gypsum	7-1/2"	-	3'	8"	35 ounces
1/2" Gypsum	20'	16"	4'	12"	45 ounces
5/8" Gypsum	28'	24"	-	-	-

NOTE: Refer to gypsum wallboard manufacturer for additional information.

If required, apply water to the side of the panel that will be in compression. Apply the water uniformly over the surface of the boards. Stack moistened boards on a flat surface and cover with plastic sheeting. Allow water to soak into the panels for at least 1 hour before application to the frame. Allow installed panels to dry for 24 hours before finishing.

CONTROL JOINTS

Please refer to ASTM C840 Section 20.3.3 - 20.4 for control requirements.

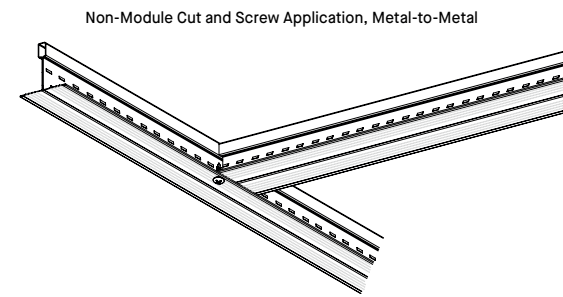

Ceiling expansion joints are installed to separate the metal suspension system when expansion joints occur in buildings, when span is over 100' or when metal changes direction. Expansion joints are required to separate a system in T-, H-, L- and U- or Circle-shaped buildings to eliminate cracking from expansion. Expansion and control joints look similar, but perform different functions.

RADIUS DIMENSIONS

ESTIMATING MATERIAL

Radius Dimension															
	10' 0"	11' 0"	12' 0"	13' 0"	14' 0"	15' 0"	16' 0"	17' 0"	18' 0"	19' 0"	20' 0"	21' 0"	22' 0"	23' 0"	24' 0"
2'	2"	2-1/4"	2"	1-7/8"	1-3/4"	1-5/8"	1-1/2"	1-1/2"	1-3/8"	1-1/4"	1-1/4"	1-1/8"	1-1/8"	1-1/8"	1"
4'	10"	9-1/8"	8-1/4"	7-5/8"	7"	6-1/2"	6-1/8"	5-3/4"	5-3/8"	5-1/8"	4-7/8"	4-5/8"	4-3/8"	4-1/4"	4"
6'	2' 0"	1'9-3/8"	1'7-3/8"	1'5-5/8"	1'4-1/4"	1'3"	1'2"	1'1-1/8"	1'0-3/8"	11-3/4"	11-1/8"	10-1/2"	10"	9-5/8"	9-1/8"
8'	4' 0"	3'5-5/8"	3'0-3/4"	2'9-1/8"	2'6-1/8"	2'3-3/4"	2'1-3/4"	2'0"	1'10-1/2"	1'9-1/4"	1'8-1/8"	1'7"	1'6-1/8"	1'5-1/4"	1'4-1/2"
	25' 0"	26' 0"	27' 0"	28' 0"	29' 0"	30' 0"	31' 0"	32' 0"	33' 0"	34' 0"	35' 0"	36' 0"	37' 0"	38' 0"	39' 0"
2'	1"	1"	7/8"	7/8"	7/8"	7/8"	3/4"	3/4"	3/4"	3/4"	3/4"	3/4"	5/8"	5/8"	5/8"
4'	3-7/8"	3-3/4"	35/8"	3-1/2"	3-3/8"	3-1/4"	3-1/8"	3"	3"	2-7/8"	2-3/4"	2-3/4"	2-5/8"	2-5/8"	2-1/2"
6'	8-3/4"	8-1/2"	81/2"	7-7/8"	7-1/2"	7-1/4"	7-1/8"	6-7/8"	6-5/8"	6-3/8"	6-1/4"	6-1/8"	5-7/8"	5-3/4"	5-5/8"
8'	1'3-3/4"	1'3-1/8"	1'25/8"	1'2"	1'2-1/2"	1'1-1/8"	1'0-5/8"	1'0-1/4"	11-1/2"	11-1/2"	11-1/8"	10-7/8"	10-1/2"	10-1/4"	10"
	40' 0"	41' 0"	42' 0"	43' 0"	44' 0"	45' 0"	46' 0"	47' 0"	48' 0"	49' 0"	50' 0"	51' 0"	52' 0"	53' 0"	54' 0"
2'	5/8"	5/8"	5/8"	5/8"	5/8"	5/8"	1/2"	1/2"	1/2"	1/2"	1/2"	1/2"	1/2"	1/2"	1/2"
4'	2-3/8"	2-3/8"	2-3/8"	2-1/4"	2-1/8"	2-1/8"	2-1/8"	2-1/8"	2"	2"	2"	1-7/8"	1-7/8"	1-3/4"	1-3/4"
6'	5-1/2"	5-3/8"	5-1/4"	5-1/8"	5"	4-7/8"	4-3/4"	4-5/8"	4-1/2"	4-1/2"	4-3/8"	4-1/4"	4-1/4"	4-1/4"	4"
8'	9-3/4"	9-1/2"	9-1/4"	9"	8-7/8"	8-5/8"	8-1/2"	8-1/4"	8-1/8"	7-7/8"	7-3/4"	7-5/8"	7-1/2"	7-3/8"	7-1/8"
	55' 0"	56' 0"	57' 0"	58' 0"	59' 0"	60' 0"	61' 0"	62' 0"	63' 0"	64' 0"	65' 0"	66' 0"	67' 0"	68' 0"	69' 0"
2'	1/2"	1/2"	1/2"	1/2"	1/2"	3/8"	3/8"	3/8"	3/8"	3/8"	3/8"	3/8"	3/8"	3/8"	3/8"
4'	1-3/4"	1-3/4"	1-3/4"	1-3/4"	1-5/8"	1-5/8"	1-5/8"	1-5/8"	1-1/2"	1-1/2"	1-1/2"	1-1/2"	1-1/2"	1-1/2"	1-3/8"
6'	4"	3-7/8"	3-7/8"	3-3/4"	3-3/4"	3-5/8"	3-5/8"	3-1/2"	3-1/2"	3-3/8"	3-3/8"	3-1/4"	3-1/4"	3-1/4"	3-1/8"
8'	7"	6-7/8"	6-3/4"	6-5/8"	6-5/8"	6-1/2"	6-3/8"	6-1/4"	6-1/8"	6"	6"	5-7/8"	5-3/4"	5-3/4"	5-5/8"
	70' 0"	71' 0"	72' 0"	73' 0"	74' 0"	75' 0"	76' 0"	77' 0"	78' 0"	79' 0"	80' 0"	81' 0"	82' 0"	83' 0"	84' 0"
2'	3/8"	3/8"	3/8"	3/8"	3/8"	3/8"	3/8"	3/8"	3/8"	3/8"	3/8"	3/8"	3/8"	3/8"	3/8"
4'	1-3/8"	1-3/8"	1-3/8"	1-3/8"	1-3/8"	1-1/4"	1-1/4"	1-1/4"	1-1/4"	1-1/4"	1-1/4"	1-1/4"	1-1/4"	1-1/4"	1-1/8"
6'	3-1/8"	3-1/8"	3"	3"	3"	2-7/8"	2-7/8"	2-7/8"	2-3/4"	2-3/4"	2-3/4"	2-3/4"	2-5/8"	2-5/8"	2-5/8"
8'	5-1/2"	5-1/2"	5-3/8"	5-1/4"	5-1/4"	5-1/8"	5-1/8"	5"	5"	4-7/8"	4-7/8"	4-3/4"	4-3/4"	4-5/8"	4-5/8"
	85' 0"	86' 0"	87' 0"	88' 0"	89' 0"	90' 0"	91' 0"	92' 0"	93' 0"	94' 0"	95' 0"	96' 0"	97' 0"	98' 0"	99' 0"
2'	3/8"	1/4"	1/4"	1/4"	1/4"	1/4"	1/4"	1/4"	1/4"	1/4"	1/4"	1/4"	1/4"	1/4"	1/4"
4'	1-1/8"	1-1/8"	1-1/8"	1-1/8"	1-1/8"	1-1/8"	1-1/8"	1-1/8"	1-1/8"	1"	1"	1"	1"	1"	1"
6'	2-5/8"	2-1/2"	2-1/2"	2-1/2"	2-1/2"	2-3/8"	2-3/8"	2-3/8"	2-3/8"	2-3/8"	2-1/4"	2-1/4"	2-1/4"	2-1/4"	2-1/4"
8'	4-1/2"	4-1/2"	4-1/2"	4-3/8"	4-3/8"	4-1/4"	4-1/4"	4-1/4"	4-1/8"	4-1/8"	4-1/8"	4"	4"	4"	3-7/8"
	100' 0"	105' 0"	110' 0"	115' 0"	120' 0"	125' 0"	130' 0"	135' 0"	140' 0"	145' 0"	150' 0"	155' 0"	160' 0"	165' 0"	170' 0"
2'	1/4"	1/4"	1/4"	1/4"	1/4"	1/4"	1/4"	1/4"	1/4"	1/4"	1/4"	1/4"	1/4"	1/8"	1/8"
4'	1"	1"	7/8"	7/8"	7/8"	3/4"	3/4"	3/4"	3/4"	3/4"	3/4"	5/8"	5/8"	5/8"	5/8"
6'	2-1/4"	2-1/8"	2"	1-7/8"	1-7/8"	1-3/4"	1-3/4"	1-3/4"	1-5/8"	1-5/8"	1-1/2"	1-1/2"	1-3/8"	1-3/8"	1-1/4"
8'	3-7/8"	3-3/4"	3-1/2"	3-3/8"	3-1/4"	3-1/8"	3"	2-7/8"	2-3/4"	2-3/4"	2-5/8"	2-1/2"	2-3/8"	2-3/8"	2-1/4"
	175' 0"	180' 0"	185' 0"	190' 0"	195' 0"	200' 0"	210' 0"	220' 0"	230' 0"	240' 0"	250' 0"				
2'	1/8"	1/8"	1/8"	1/8"	1/8"	1/8"	1/8"	1/8"	1/8"	1/8"	1/8"	1/8"	1/8"		
4'	5/8"	5/8"	1/2"	1/2"	1/2"	1/2"	1/2"	1/2"	1/2"	3/8"	3/8"	3/8"			
6'	1-1/4"	1-1/4"	1-1/4"	1-1/8"	1-1/8"	1-1/8"	1"	1"	1"	7/8"	7/8"				
8'	2-1/4"	2-1/8"	2-1/8"	2"	2"	2"	1-7/8"	1-3/4"	1-5/8"	1-5/8"	1-1/2"				

Item Number	Length	Pcs/Ctn.	LF/Ctn.	Lbs./Ctn.	Area of ceiling completed by one carton						sq. ft.
					8" O.C.	16" O.C.	24" O.C.	36" O.C.	48" O.C.	50" O.C.	
<b>DRYWALL/STUCCO GRID MAIN BEAM</b>											
HD8901	144"	20	240	71			480	720	960	1000	sq. ft.
HD8906/HD8906G90	144"	12	144	53			288	432	576	600	sq. ft.
HD8906F08/HD8906F16	144"	12	144	53							sq. ft.
<b>DRYWALL/STUCCO GRID 1-1/2" FACE CROSS TEES</b>											
XL8965	72"	36	216	78	144	288	432				sq. ft.
XL8947P/XL8947PG90**	50"	36	150	56	100	200	300				sq. ft.
XL8945P/XL8945PG90	48"	36	144	52	96	192	288				sq. ft.
XL7936G90	36"	36	108	39		144	216				sq. ft.
XL8926/XL8926G90	24"	36	72	26	48						sq. ft.

\*\* Dimensions are nominal.

Item Number	Length	Pcs/Ctn.	LF/Ctn.	Lbs./Ctn.
<b>REVERSE MOLDINGS</b>				
7857	120"	30	360	51
7858	120"	20	240	67
<b>DRYWALL ANGLE MOLDING</b>				
HD7801G90	120"	30	300	38
KAM-12	144"	30	360	31
KAM-10	120"	30	300	49
LAM-12	144"	30	360	31
LAM-151220E	144"	10	120	39
<b>SIMPLECURVE®</b>				
SC151220EQ	148"	10	124	40
SC151225	148"	10	124	26
SC21220EQ	148"	10	124	52
SC21225	148"	10	124	34

Example calculation based on 5,100 SF ceiling:  
 Main beam at 48" O.C.  
 $5,100 \text{ SF} \times .25 = 1,275 \text{ LF}$   
 $1,275 \text{ LF} \div 144 \text{ LF/Ctn} = 9 \text{ cartons needed}$   
 Cross tee at 16" O.C.  
 $5,100 \text{ SF} \times .76 = 3,876 \text{ LF}$   
 $3,876 \text{ LF} \div 144 \text{ LF/Ctn} = 27 \text{ cartons needed}$

Estimating Lineal Feet of Grid Based on Square Footage of Ceiling	
O.C. Spacing of Component	Percent of Square Footage
8"	108%
12"	100%
16"	76%
20"	60%
24"	50%
30"	40%
36"	33%
48"	25%
60"	20%

# NEXT STEPS

## 877 276-7876

Customer Service Representatives  
7:45 a.m. to 5:00 p.m. EST  
Monday through Friday

TechLine – Technical information, detail drawings, CAD design assistance, installation information, other technical services – 8:00 a.m. to 5:30 p.m. EST, Monday through Friday. FAX 800 572 8324 or email: [techline@armstrongceilings.com](mailto:techline@armstrongceilings.com)

## [armstrongceilings.com/commercial](https://armstrongceilings.com/commercial)

Latest product news

Standard and custom product information

Online catalog

CAD, Revit®, SketchUp® files

A Ceiling for Every Space® Visual Selection Tool

Product literature and samples – express service or regular delivery

Contacts – reps, where to buy, who will install



## [armstrongceilings.com/savingscalc](https://armstrongceilings.com/savingscalc)

The Armstrong Time, Material & Labor Savings Calculators are here to help you save vs. traditional construction methods.

Just plug in your job specific details and receive a complete dashboard with side-by-side comparisons, solution benefits, details, and photos that can be used on your next project or shared with a project resource.

Visit the link above to start saving time and money today!



SketchUp® is a registered trademark of Trimble Navigation Limited  
Revit® is a registered trademark of Autodesk, Inc.  
All other trademarks used herein are the property of AWI Licensing LLC and/or its affiliates  
© 2023 AWI Licensing LLC • Printed in the United States of America

TechLine / 877 276-7876  
[armstrongceilings.com/drywall](https://armstrongceilings.com/drywall)

BPCS-3540-1023

**Armstrong®**  
World Industries