

**TECHNICAL GUIDE**



**HANGING  
& FRAMING  
STUCCO/  
PLASTER  
CEILING**

**FRAMEALL™ DRYWALL GRID**  
**STUCCO/PLASTER**

**Armstrong®**  
World Industries



## FASTER. EASIER. BETTER.

FrameAll™ Drywall Grid installs faster than traditional methods, which helps you complete jobs under cost and ahead of schedule.

FrameAll Drywall Systems are manufactured to meet or exceed ASTM standards and code requirements and are engineered to provide economical alternatives to stud and track construction.

We provide pre-engineered solutions for direct-to-deck installations, vertical drops, and short spans.



## CODE COMPLIANCE YOU CAN TRUST

- Meets:
- ASTM C645
  - ASTM C840
  - ASTM C841
  - ASTM C842
  - ASTM C926
  - ASTM C1063
  - ASTM C754
  - ICC Evaluation Report Number ESR-1289
  - City of LA – RR 25348
  - Miami/Dade wind uplift – NOA #15-0127.04 – 03/17/15
  - Miami/Dade Impact – NOA #14-1204.05 – 10/07/14
  - Consult local codes for specific requirements

## PERFORMANCE (cont...)

- PeakForm® patented profile increases strength and stability for improved performance during installation
- XL® (staked-on end detail) cross tees provide secure locked connection; fast and easy to install
- SuperLock™ main beam clip is engineered for a strong secure connection and fast accurate alignment confirmed with an audible click; easy to remove and relocate



FrameAll Drywall Grid System

## TABLE OF CONTENTS

- 2 Code Compliance
- 2-3 Performance
- 4 Components
- 5-6 Moldings/Transition Moldings
- 7-8 Axiom® Trim
- 9 Axiom Building Perimeter System
- 10-11 Rout Locations
- 12-13 Accessories
- 14 System Framing
- 15 Type F Fixtures
- 16-18 Suspended Drywall Grid System
- 19 Wire Loading
- 20 Trapeze Supported Solutions
- 21 Multi-Layer Ceilings
- 22 Exterior Wind Load Data
- 23-26 UL® Fire Resistive
- 27 Seismic Installations
- 28 Load Data
- 29 Basic Products
- 30 Sound Control
- 31-32 Assemblies
- 33 Estimating

### (...cont.) PERFORMANCE



- Knurled Ridges on cross tees for speed of screw insertion during board installation
- ScrewStop™ reverse hem prevents screw spin-off on 1-1/2" wide face
- Rotary-stitched – Greater torsional strength and stability
- 1-1/2" wide face main beams and cross tees – Easy installation of screw applied gypsum wallboard
- G90 hot dipped galvanized coating – Superior corrosion resistance for exterior applications
- Heavy-duty load rating – Minimum 16 lbs./LF on main beams and cross tees
- Wind Load construction available, including Miami Dade/Broward County, Florida
- Pre-engineered stucco products space tees to match lath dimensions

### CORROSION PREVENTION

Corrosion prevention is an essential factor in the economical utilization of galvanized sheet metal for ceiling grid. Armstrong provides G40 for standard construction per ASTM C645. When conditions include exposure to extreme moisture and salt water, G90 is available per ASTM A653.

# COMPONENTS

## MAIN BEAMS

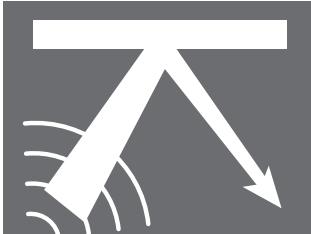
Perspective	Item No.	Length	Face Dimension	Profile Height	Duty Load	Fire Rated	Routs	Load Test Data (Lbs/LF)					
								L/360 wires at			L/240 wires at		
								2'	3'	4'	2'	3'	4'
	HD8906 HD8906G90 HD8906HRC	144"	1-1/2"	1-11/16"	Heavy Duty	Yes	51 routs – starting 2-1/4" from each end†	95.5	43.19	18.66	143	57.3	28.14
	SP135	135"	1-1/2"	1-11/16"	Heavy Duty	No	13-1/2" O.C. starting 6-3/4" from each end		43.19	18.66	139.85	52.59	28.71

† Type F fixture compatible

## CROSS TEES

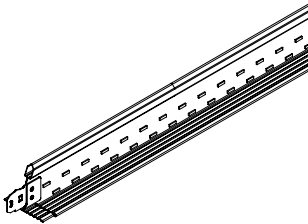
Perspective	Item No.	Length	Face Dimension	Profile Height	Fire Rated	Routs	Load Test Data (Lbs/LF)					
							L/360 wires at			L/240 wires at		
							2'	3'	4'	2'	3'	4'
	XL7936G90*	36"	1-1/2"	1-1/2"	No	–		31.3			50	
	XL8926 XL8926G90*	24"	1-1/2"	1-1/2"	Yes	3 routs – center rout and 10" from each end†	90.25				158	

NOTE: All items available in High Recycled Content (HRC) as special order.

† Type F fixture compatible

\* G90 Cross Tees are not manufactured with knurled ridges

WALL MOLDING

Perspective	Item No.	Length	Description	Profile
	7858	144"	Reverse Angle Molding nominal 1-9/16" x 15/16"	
	KAM10	120"	Knurled Angle Molding nominal 1-1/4" x 1-1/4"	
	KAM12	144"	Knurled Angle Molding nominal 1-1/4" x 1-1/4"	
	KAM12G90			
	KAM12HRC			
	KAM1510	120"	Knurled Angle Molding nominal 1-1/2" x 1-1/2"	
	KAM1512	144"	(KAM1510 & KAM1512 - 25 ga.; KAM1510EQ - 20 ga.; KAM1510EQ - 22 ga.)	
	KAM1510EQ			
	KAM21020	120"	Knurled Angle Molding nominal 2" x 2" (20 ga.)	
	KAM21025	144"	(KAM21020 - 20 ga.; KAM21025 - 25 ga.; KAM21020EQ 22 ga.)	
	KAM21020EQ			
	LAM12	144"	Locking Angle Molding nominal 1-1/4" x 1-1/4"	
	LAM12G90			
	LAM12HRC			
	LAM151220E			
	SC151220EQ	148"	SimpleCurve® Knurled Angle Molding (SC151220EQ 12' x 1.5" & SC21220EQ 12' x 2" - 20 ga.; SC151225 12' x 1.5" & SC21225 12' x 2" - 25 ga.)	
	SC151225	148"		
	SC21220EQ	148"		
	SC21225	148"		

NOTE: All items available in High Recycled Content (HRC) as special order.

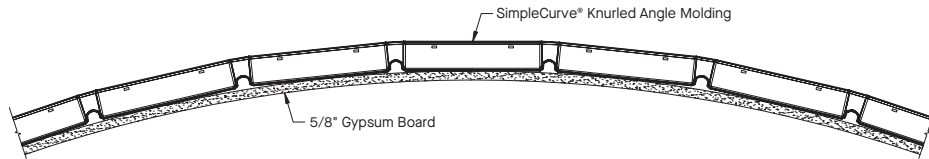

ACOUSTICAL TO DRYWALL TRANSITION MOLDING

Transition moldings make it easier to detail and build a wide variety of acoustical to drywall transitions.

Item No.	Description	Profile	
7901	9/16" Shadow Reveal Transition Molding		
7902	15/16" Shadow Reveal Transition Molding		
7903	1" Flush T Transition Molding		
7904	15/16" Flush Transition Molding		

# MOLDINGS & WIRE LOAD

## ACOUSTICAL TO DRYWALL TRANSITION MOLDING (cont...)

Item No.	Description	Profile	
7905	9/16" Flush Transition Molding		
7906	F Vertical Transition Molding		
7907	9/16" Tegular Transition Molding		
7908	15/16" Tegular Transition Molding		
7909	15/16" 1" Step Transition Molding		
7910	9/16" 1" Step Transition Molding		
7911	9/16" Shadow Reveal Transition Molding		
7912	15/16" Shadow Reveal Transition Molding		

## WIRE LOAD DETAILS

### 9-Gauge Wire Breaking Strength and Technical Data

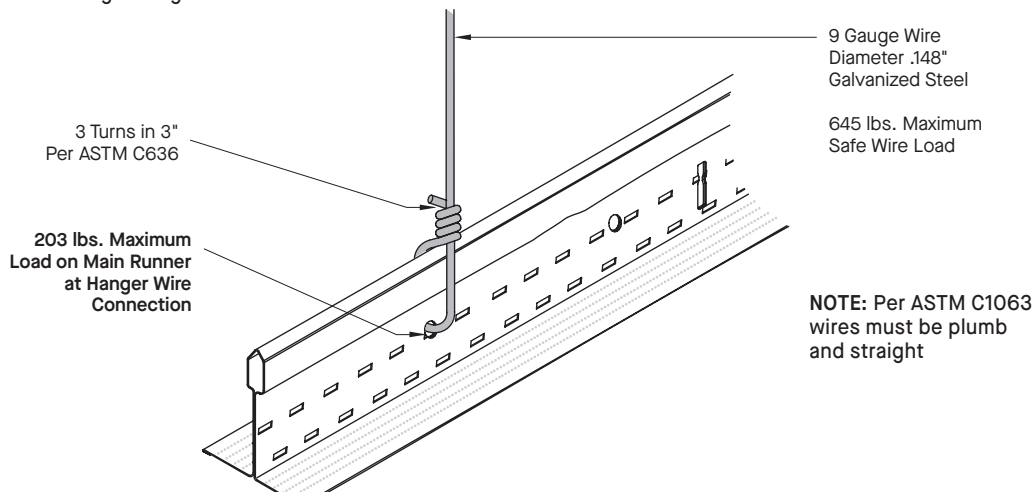

STUCCO/PLASTER GRID SUSPENSION INSTALLATION

- 1 Install the main beams with 9-gauge wires. Space main beams 36" O.C. Hanger wire and compression post spacing as required for specific wind load and plenum depth.
- 2 Install 36" cross tee to required O.C. spacing.
- 3 Isolation at perimeters is mandatory when installing any stucco system. Install perimeter channel molding at wall/ceiling junctures to support tees independent of walls. Use main beam at cut cross tee perimeters and galvanized track on main beam perimeters.
- 4 Install 3.4 Lb. 3/8" galvanized diamond mesh lath with wafer head sharp point screw to cross tees (use cadmium coated screws on exterior applications). Lath options:
  - a. 3/8", 3.4# flat rib diamond mesh lath 27" x 8'-0"
  - b. 3/8", 3.4# rib diamond mesh lath 27" x 8'-0"
  - c. 3/8", 3.4# high back rib diamond mesh lath 27" x 8'-0"
  - d. 3/8", 3.4# paper back diamond mesh lath 27" x 8'-0"
- 5 Expansion Joints – Installed in accordance with Metal Lath/Steel Framing Association Specifications/Standards.
- 6 Control Joints – Installed in accordance with Metal Lath/Steel Framing Association Specifications Standards.
- 7 Plaster stops, grounds, and corner pieces are attached to system with wafer head screws and/or 18 gauge tie wire.
- 8 Plaster or stucco mixture and thickness to be in accordance with manufacturer's recommendations and applied: ASTM C842 – For Gypsum Plaster  
ASTM C926 – For Portland Cement-based Plaster.
- 9 For exterior application use steel studs for vertical bracing (see page 10 for wind load).

For further information, contact your local representative or TechLine at 877 276 7876.

DETAILS OF STUCCO/PLASTER SYSTEMS

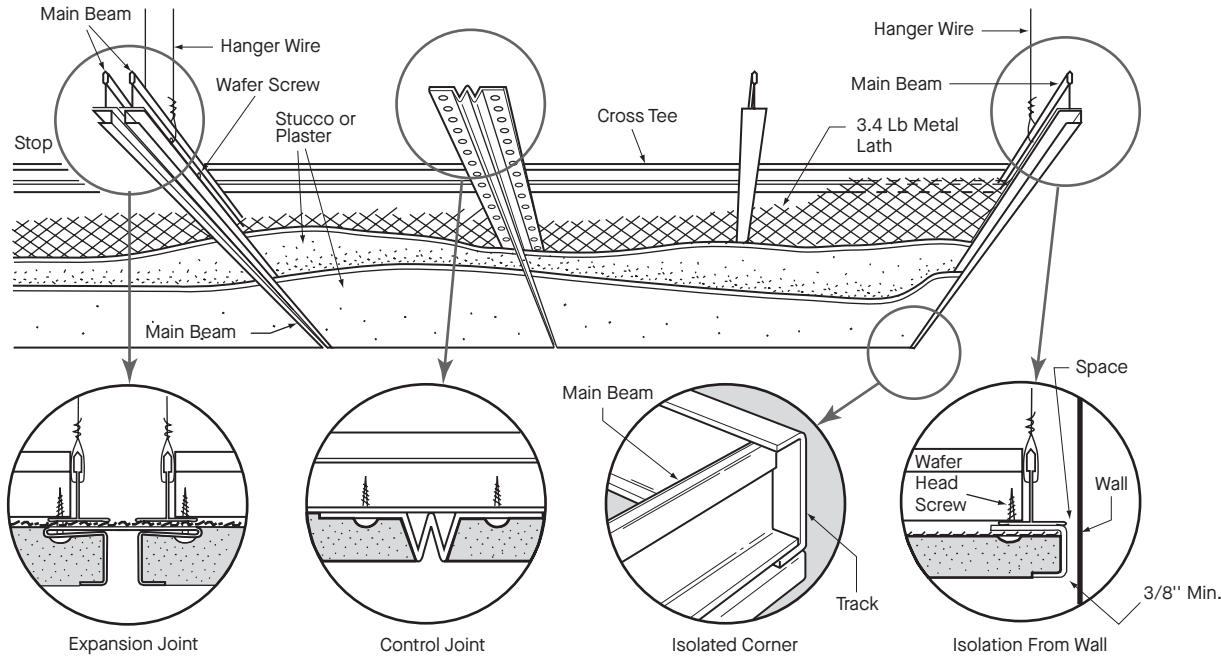

# STUCCO/PLASTER DETAILS

## DETAILS OF STUCCO/PLASTER SYSTEMS

### Suspended Metal Lath and Interior Stucco

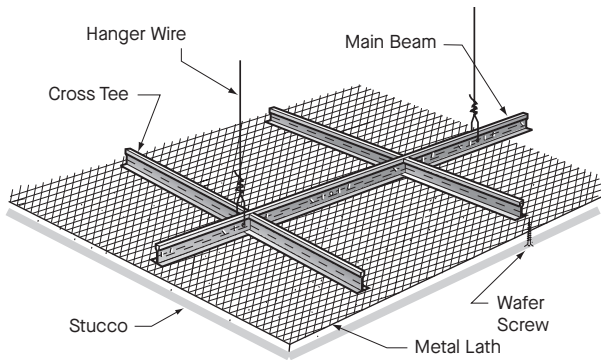

### Exterior Wind Loaded Stucco

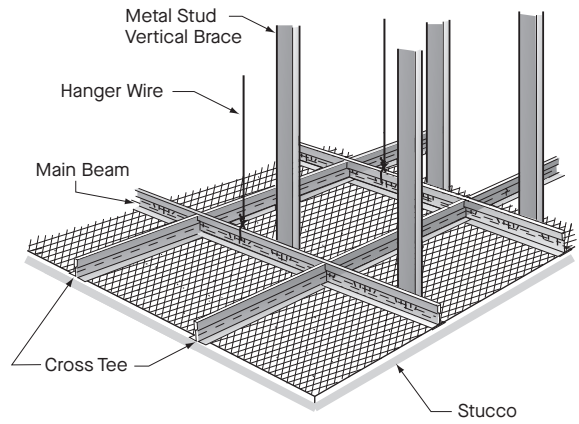

### Lighting Troffer

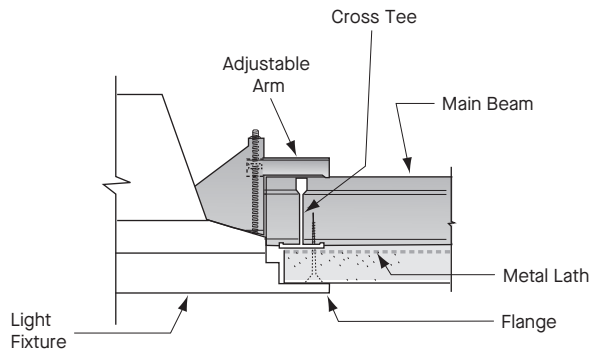

### Stucco Perimeter Stop

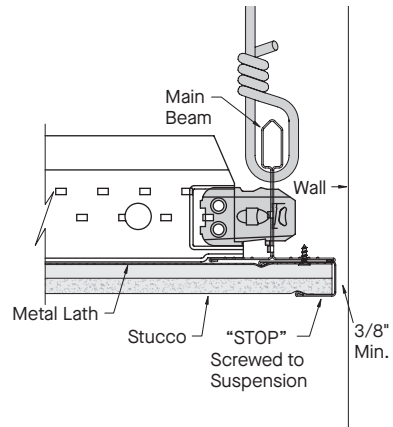

### Non-Modular Cut and Screw

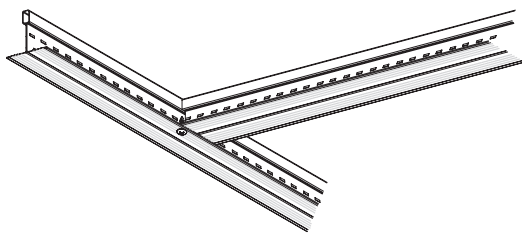



DETAILS OF STUCCO/PLASTER SYSTEMS

Rock Lath and Plaster

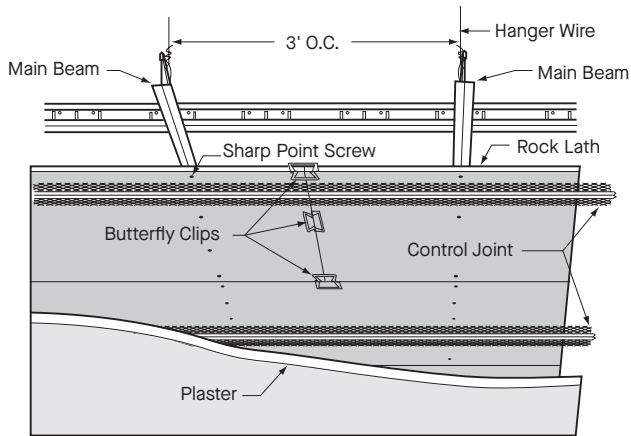

Security Metal Lath and Plaster

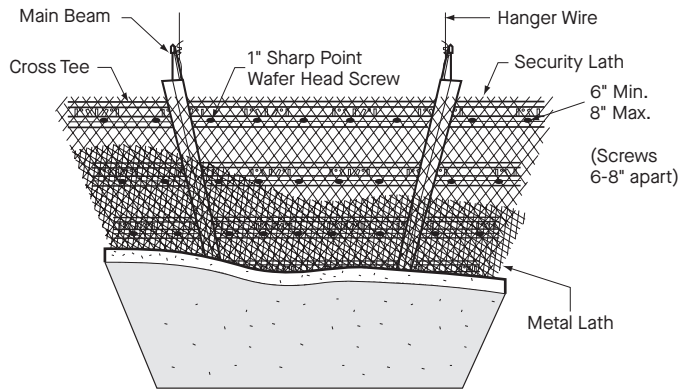

# WIND LOAD

## STUCCO SYSTEM EXTERIOR WIND LOAD & IMPACT RESISTANT CEILING DESIGN FOR NORTH AMERICA

Plenum Height (ft. - in.)	Design Wind Velocity (MPH)	Design Wind Pressure (PSF)	Compression Post Size (Inch)	Compression Post Gauge (Ga. No.)	Membrane Substrate 3/8" Ribbed Sheet lath 3.4 Lbs./SQ.YD., Per ASTM C-847	Compression Post Spacing (ft. - in.)	Main Runner Spacing (Inch)	Cross Tee Spacing (Inch)	Hanger Wire Spacing (ft. - in.)	Cross Tee Length (Feet)	Compression Post Design Load (Lbs.)
0 ↓ 6' ***	15	0.507	2 1/2" CWN	20	3/8" 3.4 Lb Lathing & 3/4"-1" Stucco	2' -11"	48	13.5	4'	4	15
	30	2.027	2 1/2" CWN	20	3/8" 3.4 Lb Lathing & 3/4"-1" Stucco	2' -9"	48	13.5	4'	4	38
	45	4.561	2 1/2" CWN	20	3/8" 3.4 Lb Lathing & 3/4"-1" Stucco	2' -11"	36	13.5	4'	3	62
	60	8.108	2 1/2" CWN	20	3/8" 3.4 Lb Lathing & 3/4"-1" Stucco	2' -9"	36	13.5	4'	3	101
	90	18.24	2 1/2" CWN	20	3/8" 3.4 Lb Lathing & 3/4"-1" Stucco	2' -5"	36	13.5	3'	3	199
	120	32.43	2 1/2" CWN	20	3/8" 3.4 Lb Lathing & 3/4"-1" Stucco	2' -5"	24	13.5	2' -6"	2	236
	140	44.15	2 1/2" CWN	18	3/8" 3.4 Lb Lathing & 3/4"-1" Stucco	2' -3"	24	13.5	2' -6"	2	301
6' 1" ↓ 10' 3" ****	172	75	2 1/2" CSJ	18	See NOA 14-1204.05 Design	2'	36	13.5	2'	3	452
	172	75	2 1/2" CSJ	18	See NOA 15-0127.04 Design	2' -6"	36	13.5	2' -6"	3	565
	15	0.507	2 1/2" CSJ	18	3/8" 3.4 Lb Lathing & 3/4"-1" Stucco	2' -11"	48	13.5	4'	4	15
	30	2.027	2 1/2" CSJ	18	3/8" 3.4 Lb Lathing & 3/4"-1" Stucco	2' -9"	48	13.5	4'	4	38
	45	4.561	2 1/2" CSJ	18	3/8" 3.4 Lb Lathing & 3/4"-1" Stucco	2' -11"	36	13.5	4'	3	62
	60	8.108	2 1/2" CSJ	18	3/8" 3.4 Lb Lathing & 3/4"-1" Stucco	2' -9"	36	13.5	4'	3	101
	90	18.24	2 1/2" CSJ	18	3/8" 3.4 Lb Lathing & 3/4"-1" Stucco	2-5	36	13.5	3'	3	199
10' 4" ↓ 15' 0" ****	120	32.43	2 1/2" CSJ	18	3/8" 3.4 Lb Lathing & 3/4"-1" Stucco	2-5	24	13.5	2' -6"	2	236
	140	44.15	2 1/2" CWN	18	3/8" 3.4 Lb Lathing & 3/4"-1" Stucco	2-3	24	13.5	2' -6"	2	301
	172	75	2 1/2" CSJ	18	See NOA 14-1204.05 Design	2'	36	13.5	2'	3	452
	172	75	2 1/2" CSJ	18	See NOA 15-0127.04 Design	2' -6"	36	13.5	2' -6"	3	565
	*15	0.507	2 1/2" CSJ	18	3/8" 3.4 Lb Lathing & 3/4"-1" Stucco	2' -11"	48	13.5	4'	4	15
	*30	2.027	2 1/2" CSJ	18	3/8" 3.4 Lb Lathing & 3/4"-1" Stucco	2' -9"	48	13.5	4'	4	38
	*45	4.561	2 1/2" CSJ	18	3/8" 3.4 Lb Lathing & 3/4"-1" Stucco	2' -11"	36	13.5	4'	3	62
15' 1" ↓ 20' 0" ****	*60	8.108	2 1/2" CSJ	18	3/8" 3.4 Lb Lathing & 3/4"-1" Stucco	2' -9"	36	13.5	4'	3	101
	*90	18.24	2 1/2" CSJ	18	3/8" 3.4 Lb Lathing & 3/4"-1" Stucco	2-5	36	13.5	3'	3	199
	*120	32.43	2 1/2" CSJ	18	3/8" 3.4 Lb Lathing & 3/4"-1" Stucco	2-5	24	13.5	2' -6"	2	236
	*140	44.15	2 1/2" CWN	18	3/8" 3.4 Lb Lathing & 3/4"-1" Stucco	2-3	24	13.5	2' -6"	2	301
	**172	75	2 1/2" CSJ	18	See NOA 14-1204.05 Design	2'	36	13.5	2'	3	452
	**172	75	2 1/2" CSJ	18	See NOA 15-0127.04 Design	2' -6"	36	13.5	2' -6"	3	565
	**15	0.507	3 5/8" CSJ	18	3/8" 3.4 Lb Lathing & 3/4"-1" Stucco	2' -11"	48	13.5	4'	4	15
15' 1" ↓ 20' 0" ****	**30	2.027	3 5/8" CSJ	18	3/8" 3.4 Lb Lathing & 3/4"-1" Stucco	2' -9"	48	13.5	4'	4	38
	**45	4.561	3 5/8" CSJ	18	3/8" 3.4 Lb Lathing & 3/4"-1" Stucco	2' -11"	36	13.5	4'	3	62
	**60	8.108	3 5/8" CSJ	18	3/8" 3.4 Lb Lathing & 3/4"-1" Stucco	2' -9"	36	13.5	4'	3	101
	**90	18.24	3 5/8" CSJ	18	3/8" 3.4 Lb Lathing & 3/4"-1" Stucco	2-5	36	13.5	3'	3	199
	**120	32.43	3 5/8" CSJ	18	3/8" 3.4 Lb Lathing & 3/4"-1" Stucco	2-5	24	13.5	2' -6"	2	236
	**140	44.15	2 1/2" CWN	18	3/8" 3.4 Lb Lathing & 3/4"-1" Stucco	2-3	24	13.5	2' -6"	2	301
	**172	75	3 5/8" CSJ	18	See NOA 14-1204.05 Design	2'	36	13.5	2'	3	452
**172	75	3 5/8" CSJ	18	See NOA 15-0127.04 Design	2' -6"	36	13.5	2' -6"	3	565	

Ceiling System = SP135-G90 Main Runner 11.25 ft. / XL 7936-G90 Cross Runner 3 ft. / XL 8926-G90 Cross Runner 2 ft. / # 9 Ga. H.D.G. Hanger Wire

\* Note: 1-1/2" 16ga. U-Channel Bridging required at Mid Span for 10'4" up to 15'0".

\*\* Note: 1-1/2" 16ga. U-Channel Bridging required at 1/3rd Points for 15'1" up to 20'0".

\*\*\* Compression Post and Ceiling system Tested at the Plenum design depth shown here for Positive and Negative Wind Speed pressure Loads as listed.

\*\*\*\* Compression Post Assemblies at this Plenum design depth Calculated by Dietrich Design Group. For building heights over 20 feet refer to ASCE 7-10 chapter 6 Wind Loads Stud Products & Properties Based on Dietrich Industries Inc.

Non-Impact Miami / Dade County EIFS Exterior Ceiling Design NOA 14-1204.05 Design Hurricane Zone Approved

Impact Rated EIFS Exterior Ceiling Design with 5/8" F/R plywood added to membrane Miami / Dade County NOA 15-0127.04 Hurricane Zone Approved

### CONTROL JOINTS / EXPANSION JOINTS

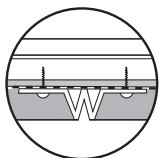

Reference section 7.11.4.1-7.11.4.3 for location and spacing of control joints.

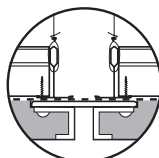

Ceiling expansion joints are installed to separate the metal suspension system when expansion joints occur in buildings, or when metal changes direction. Expansion joints are required to separate a system in T-, H-, I-, and U- or circle-shaped buildings to eliminate cracking from expansion.

### MEMBRANE LOAD VALUES

Component Combinations	Maximum Load in lbs./ft. <sup>2</sup> at Hanger Wire/Cross Tee Spacing	
	36"/16"	36"/13.5"
HD8906/XL7936G90 (mains 36" O.C.)	13.37	
HD8906/XL8926 (mains 24" O.C.)	20.5	
SP135/XL7936G90 (mains 36" O.C.)		13.37

EXTERIOR WIND LOAD BRACING TO CONCRETE SLAB

For maximum wind speed of 172 MPH.

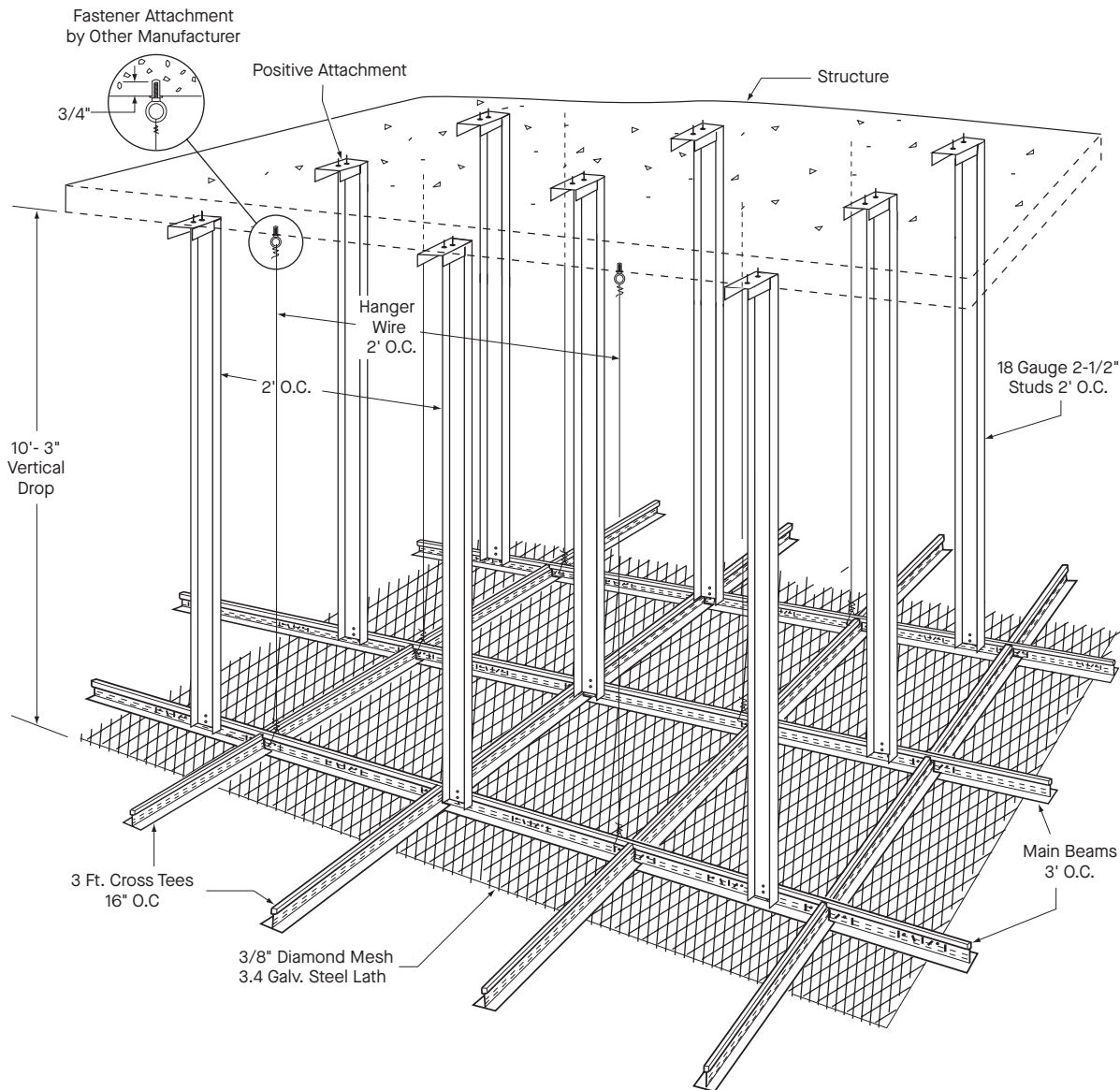

NOTES

- |   |   |
|---|---|
| <p>1 Wind Load Brace 2-1/2" 18-Gauge Steel 2' O.C.</p> <p>2 From 0' to 6' 22-Gauge 2-1/2" Metal Studs Minimum<br/>From 6' to 10'-3" 18 Gauge 2-1/2" Metal Studs Minimum.</p> <p>3 From 10'-4" to 15' 18-Gauge 2-1/2" Metal Studs Minimum<br/>16 Gauge CRC Mid Span.</p> <p>4 From 15' to 20' 18 Gauge 2-1/2" Metal Studs Minimum<br/>16 Gauge CRC 1/3 Points.</p> | <p>5 Item 3 and 4 above CRC Bracing Shown on<br/>Other Drawings.</p> <p>6 Main Beams 3' O.C. / Cross Tees 16" O.C.</p> <p>7 Positive Attachment Metal Studs Top and Bottom.</p> <p>8 #9 Hanger Wire – as shown above.</p> |
|---|---|

## WIND LOAD BRACING

### EXTERIOR WIND LOAD BRACING TO METAL BAR JOISTS

For maximum wind speed of 172 MPH.

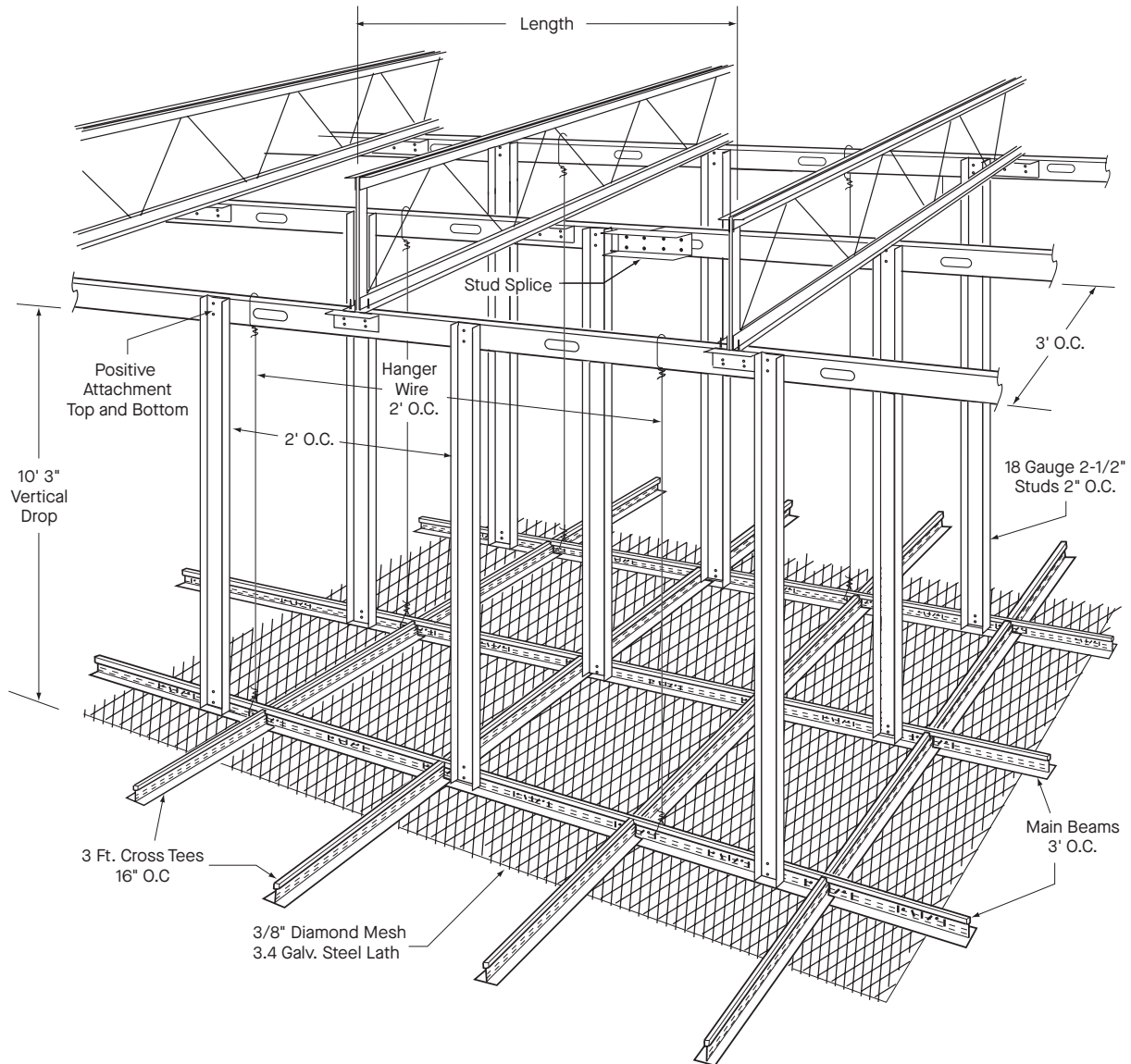

#### NOTES

- 1 18-Gauge 2-1/2' steel studs, 10'-3" vertical drop.
- 2 Positive Attachment top and bottom.
- 3 Hanger Wire 2' O.C.
- 4 Main Beams 3' O.C. / Cross Tees 16" O.C 3' long.

EXTERIOR WIND LOAD BRACING TO METAL BAR JOISTS

For maximum wind speed of 172 MPH.

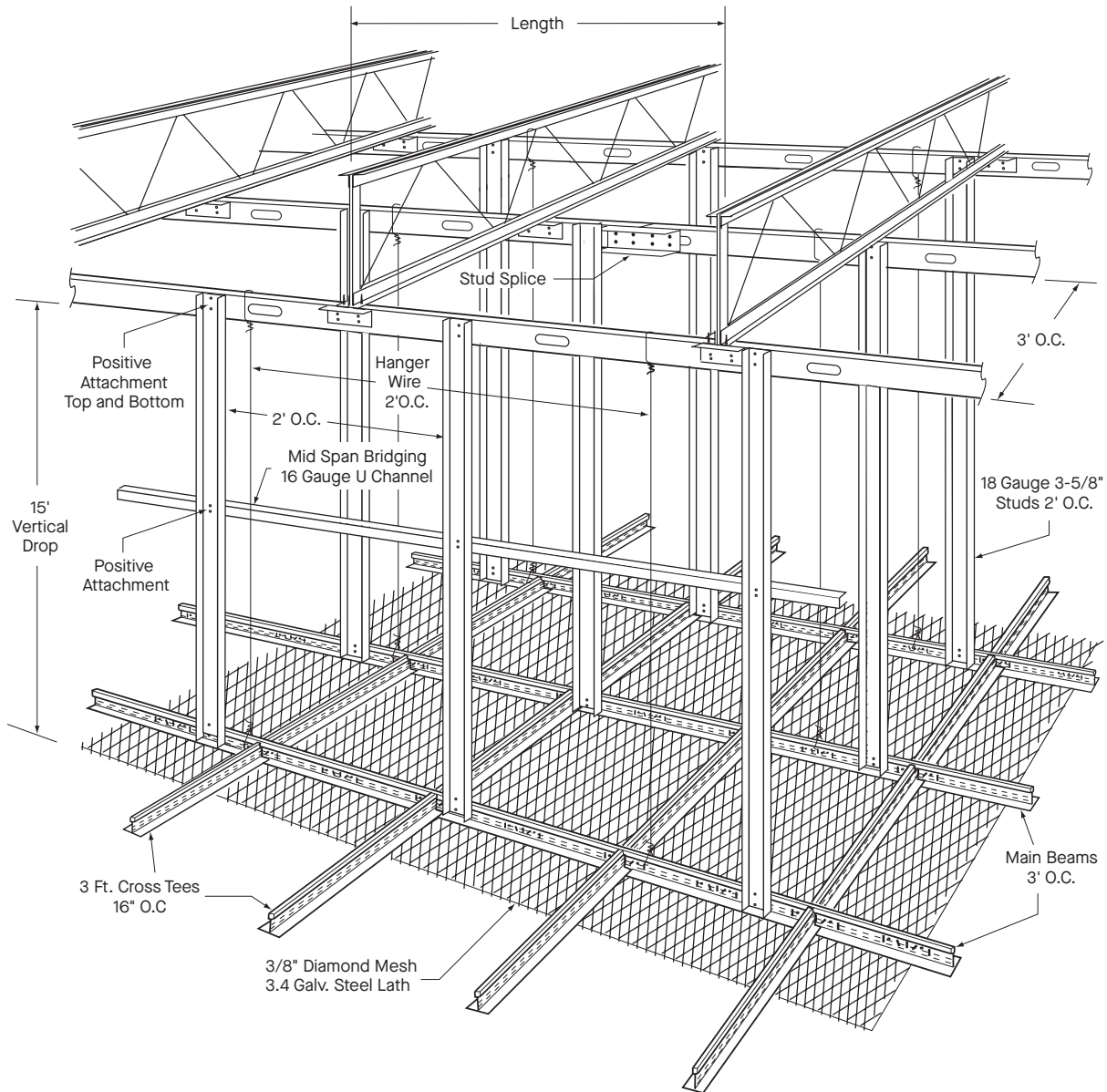

NOTES

- 1 16-Gauge CRC Channel Bracing required at Mid Span for 10' - 15' vertical drop.
- 2 Positive Attachment top and bottom.
- 3 18-Gauge 3-5/8" studs 2' O.C.
- 4 Main Beams 3' O.C. / Cross Tees 16" O.C 3' long.
- 5 #9 Hanger Wire

# WIND LOAD BRACING

## EXTERIOR WIND LOAD BRACING TO METAL BAR JOISTS

For maximum wind speed of 172 MPH.

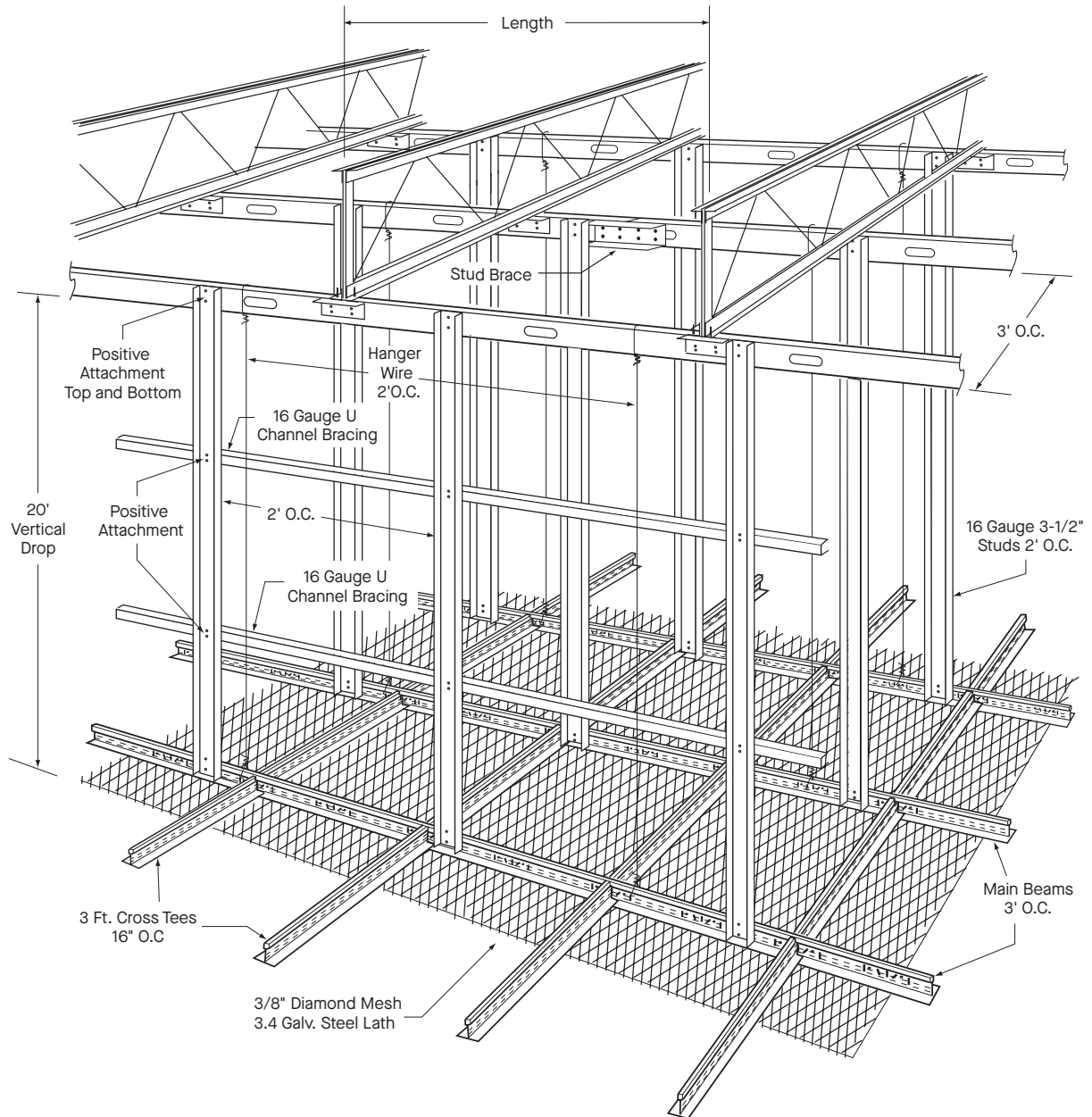

### NOTES

- 1 #16-Gauge CRC Channel Bracing required at 1/3 Point at 20' vertical drop.
- 2 Positive Attachment top and bottom.
- 3 16-Gauge 3-1/2" studs 2' O.C.
- 4 Main Beams 3' O.C. / Cross Tees 16" O.C 3' long.

ESTABLISHING AN ARC

Draw radius on template (plywood, gypsum board, etc.)

- 1 Establish a center line.
- 2 Mark 2' increments on line perpendicular to center line.

3 At 2' marks, identify points of arc below perpendicular line (maintain consistent spacing of point) See radius charts on page 17.

4 Connect points to form a smooth arc.

Example: 43' arc using chart on page 19

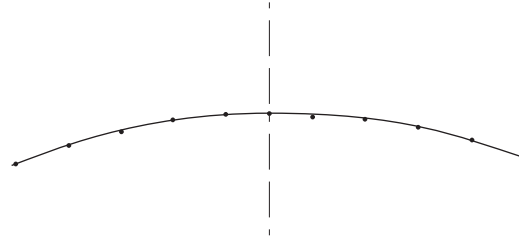
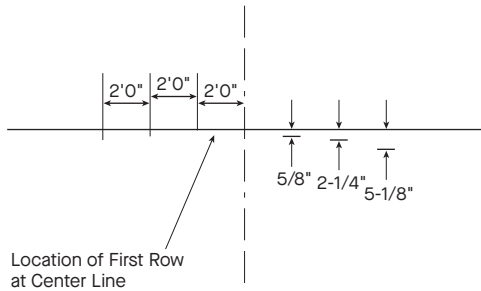

COMPLETING THE TEMPLATE - OPTION 1

- 1 Cut along the arc and remove section of template.
- 2 Cut main beam as required and position along the cut radius on the template (use chart on page 19).

3 Screw RC2 clips to faceted main beam at all knockout locations. \*

4 On the template, mark a rout location reference point to maintain consistent rout location.

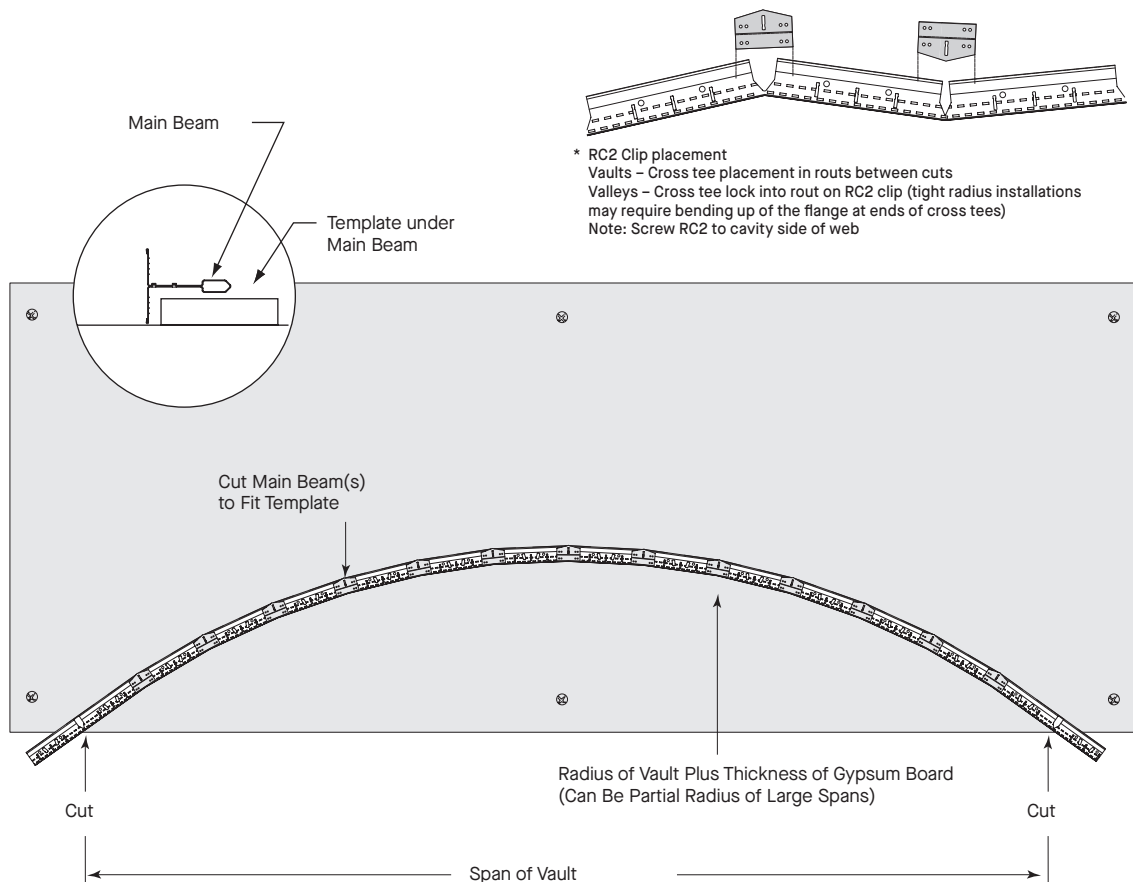

# MAKING A TEMPLATE

## COMPLETING THE TEMPLATE - OPTION 2

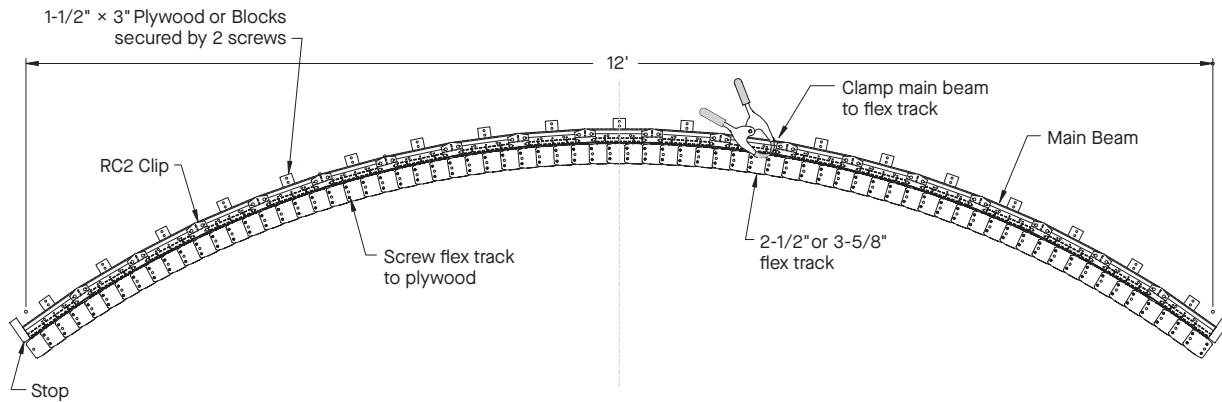

- 1 Draw radius on board.
- 2 Screw flex track to board along radius line.
- 3 Cut main beams as required and position along the flex track on the template.
- 4 Screw RC2\* clips to faceted main beam at all knockout locations.
- 5 On the template, mark a rout location reference point to maintain consistent rout location. Contractors' efficiency and understanding of the suspended grid system construction provides performance benefits and cost savings.

- An unlimited range of vaults and valleys can be constructed using faceted main beams made on the job to meet design needs.
- Single and multiple curved ceilings can be framed quickly and easily.

\*Screw RC2 on cavity side of web

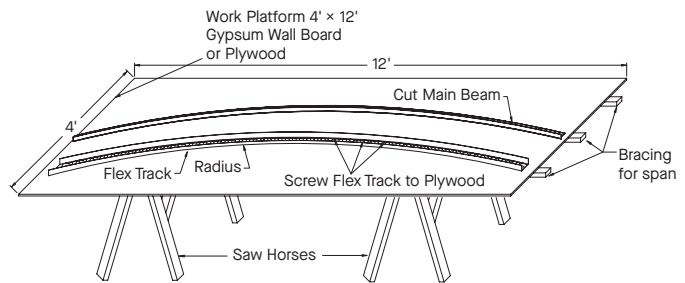



RADIUS DIMENSIONS

Radius Dimension		10' 0"	11' 0"	12' 0"	13' 0"	14' 0"	15' 0"	16' 0"	17' 0"	18' 0"	19' 0"	20' 0"	21' 0"	22' 0"	23' 0"	24' 0"	
2' Increments from Center Line	2'	2"	2-1/4"	2"	1-7/8"	1-3/4"	1-5/8"	1-1/2"	1-1/2"	1-3/8"	1-1/4"	1-1/4"	1-1/8"	1-1/8"	1-1/8"	1"	
	4'	10"	9-1/8"	8-1/4"	7-5/8"	7"	6-1/2"	6-1/8"	5-3/4"	5-3/8"	5-1/8"	4-7/8"	4-5/8"	4-3/8"	4-1/4"	4"	
	6'	2' 0"	1'9-3/8"	1'7-3/8"	1'5-5/8"	1'4-1/4"	1'3"	1'2"	1'1-1/8"	1'0-3/8"	11-3/4"	11-1/8"	10-1/2"	10"	9-5/8"	9-1/8"	
	8'	4' 0"	3'5-5/8"	3'0-3/4"	2'9-1/8"	2'6-1/8"	2'3-3/4"	2'1-3/4"	2'0"	1'10-1/2"	1'9-1/4"	1'8-1/8"	17"	1'6-1/8"	1'5-1/4"	1'4-1/2"	
		25' 0"	26' 0"	27' 0"	28' 0"	29' 0"	30' 0"	31' 0"	32' 0"	33' 0"	34' 0"	35' 0"	36' 0"	37' 0"	38' 0"	39' 0"	
	2'	1"	1"	7/8"	7/8"	7/8"	7/8"	3/4"	3/4"	3/4"	3/4"	3/4"	3/4"	3/4"	5/8"	5/8"	5/8"
	4'	3-7/8"	3-3/4"	35/8"	3-1/2"	3-3/8"	3-1/4"	3-1/8"	3"	3"	2-7/8"	2-3/4"	2-3/4"	2-5/8"	2-5/8"	2-1/2"	
	6'	8-3/4"	8-1/2"	81/2"	7-7/8"	7-1/2"	7-1/4"	7-1/8"	6-7/8"	6-5/8"	6-3/8"	6-1/4"	6-1/8"	5-7/8"	5-3/4"	5-5/8"	
	8'	1'3-3/4"	1'3-1/8"	1'25/8"	1'2"	1'2-1/2"	1'1-1/8"	1'0-5/8"	1'0-1/4"	11-1/2"	11-1/2"	11-1/8"	10-7/8"	10-1/2"	10-1/4"	10"	
		40' 0"	41' 0"	42' 0"	43' 0"	44' 0"	45' 0"	46' 0"	47' 0"	48' 0"	49' 0"	50' 0"	51' 0"	52' 0"	53' 0"	54' 0"	
	2'	5/8"	5/8"	5/8"	5/8"	5/8"	5/8"	1/2"	1/2"	1/2"	1/2"	1/2"	1/2"	1/2"	1/2"	1/2"	
	4'	2-3/8"	2-3/8"	2-3/8"	2-1/4"	2-1/8"	2-1/8"	2-1/8"	2-1/8"	2"	2"	2"	1-7/8"	1-7/8"	1-3/4"	1-3/4"	
	6'	5-1/2"	5-3/8"	5-1/4"	5-1/8"	5"	4-7/8"	4-3/4"	4-5/8"	4-1/2"	4-1/2"	4-3/8"	4-1/4"	4-1/4"	4-1/4"	4"	
	8'	9-3/4"	9-1/2"	9-1/4"	9"	8-7/8"	8-5/8"	8-1/2"	8-1/4"	8-1/8"	7-7/8"	7-3/4"	7-5/8"	7-1/2"	7-3/8"	7-1/8"	
		55' 0"	56' 0"	57' 0"	58' 0"	59' 0"	60' 0"	61' 0"	62' 0"	63' 0"	64' 0"	65' 0"	66' 0"	67' 0"	68' 0"	69' 0"	
	2'	1/2"	1/2"	1/2"	1/2"	1/2"	3/8"	3/8"	3/8"	3/8"	3/8"	3/8"	3/8"	3/8"	3/8"	3/8"	
	4'	1-3/4"	1-3/4"	1-3/4"	1-3/4"	1-5/8"	1-5/8"	1-5/8"	1-5/8"	1-1/2"	1-1/2"	1-1/2"	1-1/2"	1-1/2"	1-1/2"	1-3/8"	
	6'	4"	3-7/8"	3-7/8"	3-3/4"	3-3/4"	3-5/8"	3-5/8"	3-1/2"	3-1/2"	3-3/8"	3-3/8"	3-1/4"	3-1/4"	3-1/4"	3-1/8"	
	8'	7"	6-7/8"	6-3/4"	6-5/8"	6-5/8"	6-1/2"	6-3/8"	6-1/4"	6-1/8"	6"	6"	5-7/8"	5-3/4"	5-3/4"	5-5/8"	
		70' 0"	71' 0"	72' 0"	73' 0"	74' 0"	75' 0"	76' 0"	77' 0"	78' 0"	79' 0"	80' 0"	81' 0"	82' 0"	83' 0"	84' 0"	
	2'	3/8"	3/8"	3/8"	3/8"	3/8"	3/8"	3/8"	3/8"	3/8"	3/8"	3/8"	3/8"	3/8"	3/8"	3/8"	
	4'	1-3/8"	1-3/8"	1-3/8"	1-3/8"	1-3/8"	1-1/4"	1-1/4"	1-1/4"	1-1/4"	1-1/4"	1-1/4"	1-1/4"	1-1/4"	1-1/4"	1-1/8"	
	6'	3-1/8"	3-1/8"	3"	3"	3"	2-7/8"	2-7/8"	2-7/8"	2-3/4"	2-3/4"	2-3/4"	2-3/4"	2-5/8"	2-5/8"	2-5/8"	
	8'	5-1/2"	5-1/2"	5-3/8"	5-1/4"	5-1/4"	5-1/8"	5-1/8"	5"	5"	4-7/8"	4-7/8"	4-3/4"	4-3/4"	4-5/8"	4-5/8"	
	85' 0"	86' 0"	87' 0"	88' 0"	89' 0"	90' 0"	91' 0"	92' 0"	93' 0"	94' 0"	95' 0"	96' 0"	97' 0"	98' 0"	99' 0"		
2'	3/8"	1/4"	1/4"	1/4"	1/4"	1/4"	1/4"	1/4"	1/4"	1/4"	1/4"	1/4"	1/4"	1/4"	1/4"		
4'	1-1/8"	1-1/8"	1-1/8"	1-1/8"	1-1/8"	1-1/8"	1-1/8"	1-1/8"	1-1/8"	1"	1"	1"	1"	1"	1"		
6'	2-5/8"	2-1/2"	2-1/2"	2-1/2"	2-1/2"	2-3/8"	2-3/8"	2-3/8"	2-3/8"	2-3/8"	2-1/4"	2-1/4"	2-1/4"	2-1/4"	2-1/4"		
8'	4-1/2"	4-1/2"	4-1/2"	4-3/8"	4-3/8"	4-1/4"	4-1/4"	4-1/4"	4-1/8"	4-1/8"	4-1/8"	4"	4"	4"	3-7/8"		
	100' 0"	105' 0"	110' 0"	115' 0"	120' 0"	125' 0"	130' 0"	135' 0"	140' 0"	145' 0"	150' 0"	155' 0"	160' 0"	165' 0"	170' 0"		
2'	1/4"	1/4"	1/4"	1/4"	1/4"	1/4"	1/4"	1/4"	1/4"	1/4"	1/4"	1/4"	1/8"	1/8"	1/8"		
4'	1"	1"	7/8"	7/8"	7/8"	3/4"	3/4"	3/4"	3/4"	3/4"	3/4"	5/8"	5/8"	5/8"	5/8"		
6'	2-1/4"	2-1/8"	2"	1-7/8"	1-7/8"	1-3/4"	1-3/4"	1-5/8"	1-5/8"	1-1/2"	1-1/2"	1-3/8"	1-3/8"	1-3/8"	1-1/4"		
8'	3-7/8"	3-3/4"	3-1/2"	3-3/8"	3-1/4"	3-1/8"	3"	2-7/8"	2-3/4"	2-3/4"	2-5/8"	2-1/2"	2-3/8"	2-3/8"	2-1/4"		
	175' 0"	180' 0"	185' 0"	190' 0"	195' 0"	200' 0"	210' 0"	220' 0"	230' 0"	240' 0"	250' 0"						
2'	1/8"	1/8"	1/8"	1/8"	1/8"	1/8"	1/8"	1/8"	1/8"	1/8"	1/8"						
4'	5/8"	5/8"	1/2"	1/2"	1/2"	1/2"	1/2"	1/2"	3/8"	3/8"	3/8"						
6'	1-1/4"	1-1/4"	1-1/4"	1-1/8"	1-1/8"	1-1/8"	1"	1"	1"	7/8"	7/8"						
8'	2-1/4"	2-1/8"	2-1/8"	2"	2"	2"	1-7/8"	1-3/4"	1-5/8"	1-5/8"	1-1/2"						

# NEXT STEPS

## 877 276-7876

Customer Service Representatives  
7:45 a.m. to 5:00 p.m. EST  
Monday through Friday

TechLine – Technical information, detail drawings, CAD design assistance, installation information, other technical services – 8:00 a.m. to 5:30 p.m. EST, Monday through Friday. FAX 800 572 8324 or email: [techline@armstrongceilings.com](mailto:techline@armstrongceilings.com)

## [armstrongceilings.com/commercial](https://armstrongceilings.com/commercial)

Latest product news

Standard and custom product information

Online catalog

CAD, Revit®, SketchUp® files

A Ceiling for Every Space® Visual Selection Tool

Product literature and samples – express service or regular delivery

Contacts – reps, where to buy, who will install



## [armstrongceilings.com/savingscalc](https://armstrongceilings.com/savingscalc)

The Armstrong Time, Material & Labor Savings Calculators are here to help you save vs. traditional construction methods.

Just plug in your job specific details and receive a complete dashboard with side-by-side comparisons, solution benefits, details, and photos that can be used on your next project or shared with a project resource.

Visit the link above to start saving time and money today!



Lutron® is a registered trademark of Lutron Electronics Co., Inc.; Revit® is a registered trademark of Autodesk, Inc.; SketchUp® is a registered trademark of Trimble Inc. All other trademarks used herein are the property of AWI Licensing LLC and/or its affiliates © 2024 AWI Licensing LLC • Printed in the United States of America

TechLine / 877 276-7876  
[armstrongceilings.com/drywall](https://armstrongceilings.com/drywall)

BPCS-3541-424

**Armstrong®**  
World Industries