



TECHNICAL GUIDE



HANGING
& FRAMING
EIFS/DIRECT
APPLIED
CEILINGS

FRAMEALL™ DRYWALL GRID

SYNTHETIC STUCCO

Armstrong®
World Industries



FASTER. EASIER. BETTER.

FrameAll™ Drywall Grid installs faster than traditional methods, which helps you complete jobs under cost and ahead of schedule.

FrameAll Drywall Systems are manufactured to meet or exceed ASTM standards and code requirements and are engineered to provide economical alternatives to stud and track construction.

We provide pre-engineered solutions for direct-to deck installations, vertical drops, and short spans. This makes Armstrong ShortSpan® Drywall Framing perfect for use in corridors, small room configurations, restrooms, and storage closets.



CODE COMPLIANCE YOU CAN TRUST

- Meets:
- ASTM C645
- ASTM C840
- ASTM C754
- ICC Evaluation Report Number ESR-1289
- Department of State Architect – DSA PA105
- City of LA – RR 25348
- Miami/Dade wind uplift – NOA #15-0127.04 03/17/015
- Miami/Dade Impact – NOA #14-1204.05-10/07/14
- Consult local codes for specific requirements

PERFORMANCE (cont...)

- PeakForm® patented profile increases strength and stability for improved performance during installation
- XL® (staked-on end detail) cross tees provide secure locked connection; fast and easy to install
- SuperLock™ main beam clip is engineered for a strong secure connection and fast accurate alignment confirmed with an audible click; easy to remove and relocate



FrameAll™ Drywall Grid Installation

TABLE OF CONTENTS

- 2 Code Compliance
- 2-3 Performance
- 4 Components
- 5-6 Moldings
- 6 Wire Loads
 - Stucco/Plaster Grid
- 7 Suspension Installation
- 8-9 Stucco/Plaster Details
- 10 Wind Load
 - Exterior Wind Load Bracing to Concrete Slab
- 11 Exterior Wind Load Bracing to Meet Metal Bar Joists
- 12-14 Making a Template
- 15-16 Wind Load and Impact
- 17 Radius Chart

(...cont.) PERFORMANCE

- Knurled Ridges on cross tees for speed of screw insertion during board installation
- ScrewStop® reverse hem prevents screw spin-off on 1-1/2" wide face
- Rotary-stitched – Greater torsional strength and stability
- 1-1/2" wide face main beams and cross tees – Easy installation of screw applied gypsum wallboard
- G40 AND G90 hot dipped galvanized coating – Superior corrosion resistance for exterior applications
- Heavy-duty load rating – Minimum 16 lbs./LF on main beams and cross tees
- Wind Load construction available, including Miami Dade/Broward County, Florida
- Pre-engineered stucco products space tees to match lath dimensions

CORROSION PREVENTION

Corrosion prevention is an essential factor in the economical utilization of galvanized sheet metal for ceiling grid. Armstrong provides G40 for standard construction per ASTM C645. When conditions include exposure to extreme moisture and salt water, G90 is available per ASTM A653.

COMPONENTS

MAIN BEAMS

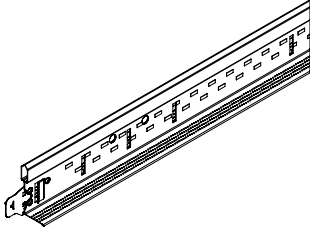
| Perspective | Item No. | Length | Face Dimension | Profile Height | Duty Load | Fire Rated | Routes | Load Test Data (Lbs/LF) | | | | | |
|---|-----------|--------|----------------|----------------|------------|------------|--|-------------------------|-------|------|----------------|-------|-------|
| | | | | | | | | L/360 wires at | | | L/240 wires at | | |
| | | | | | | | | 2' | 3' | 4' | 2' | 3' | 4' |
|  | HD8906 | 144" | 1-1/2" | 1-11/16" | Heavy Duty | Yes | 51 routes – starting 2-1/4" from each end† | 95.5 | 28.14 | 95.5 | 43.19 | 18.66 | 43.19 |
| | HD8906G90 | | | | | | | | | | | | |
| | HD8906HRC | | | | | | | | | | | | |

† Type F fixture compatible

CROSS TEES

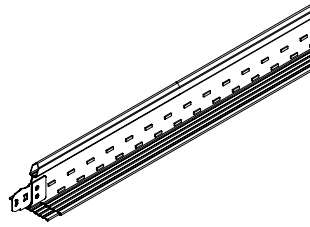
| Perspective | Item No. | Length | Face Dimension | Profile Height | Fire Rate | Routes | Load Test Data (Lbs/LF) | | | | | | |
|--|-------------|--------|----------------|----------------|---|--|-------------------------|-----|------|----------------|--|-------|-------|
| | | | | | | | L/360 wires at | | | L/240 wires at | | | |
| | | | | | | | 50° | 50° | | | | | |
|  | XL8947P | 50" | 1-1/2" | 1-1/2" | Yes | 8 routes – starting 10" from each end† | 31.3 | | | | | | 31.3 |
| | XL8947PG90* | | | | | | | | | | | | |
| | XL8945P | 50" | 1-1/2" | 1-1/2" | Yes | 2 routes – 12" from each end† | - | | 15.0 | | | | 22.5 |
| | XL8945PG90* | | | | | | | | | | | | |
| | XL8945HRC | | | | | | | | | | | | |
| | XL7936G90* | 36" | 1-1/2" | 1-1/2" | No | none | 33.3 | | | | | | 50.0 |
| | XL8925 | 26" | 1-1/2" | 1-1/2" | Yes | 2 routes – 12" from each end† | 98.0 | | | | | | 117.0 |
| XL8925G90* | | | | | | | | | | | | | |
| XL8926 | 24" | 1-1/2" | 1-1/2" | Yes | 3 routes – center rout and 10" from each end† | 129.0 | | | | | | 158.0 | |
| XL8926G90* | | | | | | | | | | | | | |

NOTE: All items available in High Recycled Content (HRC) as special order.

† Type F fixture compatible

* G90 Cross Tees are not manufactured with knurled ridges

WALL MOLDING

| Perspective | Item No. | Length | Description | Profile |
|-------------|--|------------------------------|---|---------|
| | 7858 | 144" | Reverse Angle Molding nominal 1-9/16" x 15/16" | |
| | KAM10 | 120" | Knurled Angle Molding nominal 1-1/4" x 1-1/4" | |
| | KAM12 KAM12G90 KAM12HRC | 144" | Knurled Angle Molding nominal 1-1/4" x 1-1/4" | |
| | KAM1510 | 120" | Knurled Angle Molding nominal 1-1/2" x 1-1/2" | |
| | KAM1512 KAM151020 KAM151020EQ | 144" | (KAM1510 & KAM1512 - 25 ga.; KAM151020 - 20 ga.; KAM151020EQ - 22 ga.) | |
| | KAM21020 | 120" | Knurled Angle Molding nominal 2" x 2" (20 ga.) | |
| | KAM21025 KAM21020EQ | 144" | (KAM21020 - 20 ga.; KAM21025 - 25 ga.; KAM21020EQ 22 ga.) | |
| | LAM12 LAM12G90 LAM12HRC LAM151220E | 144" | Locking Angle Molding nominal 1-1/4" x 1-1/4" | |
| | SC151220EQ SC151225 SC21220EQ SC21225 | 148" 148" 148" 148" | SimpleCurve™ Knurled Angle Molding (SC151220EQ 12' x 1.5" & SC21220EQ 12' x 2" - 20 ga.; SC151225 12' x 1.5" & SC21225 12' x 2" - 25 ga.) | |

NOTE: All items available in High Recycled Content (HRC) as special order.

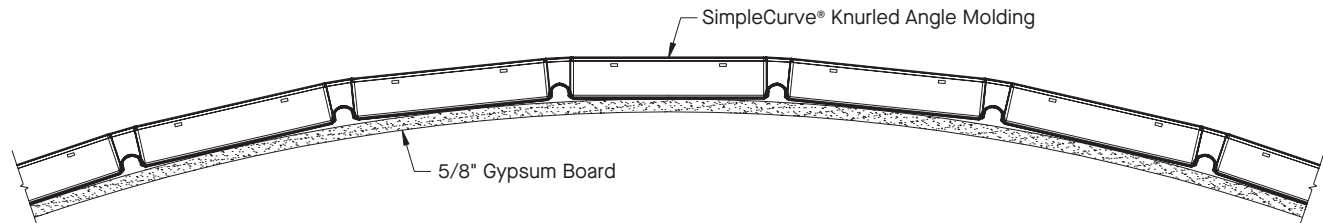

WIRE LOAD DETAILS

12 Gauge Wire Breaking Strength and Technical Data

12 Gauge Wire
Diameter .105"
Galvanized Steel
375 lbs. Maximum
Safe Wire Load

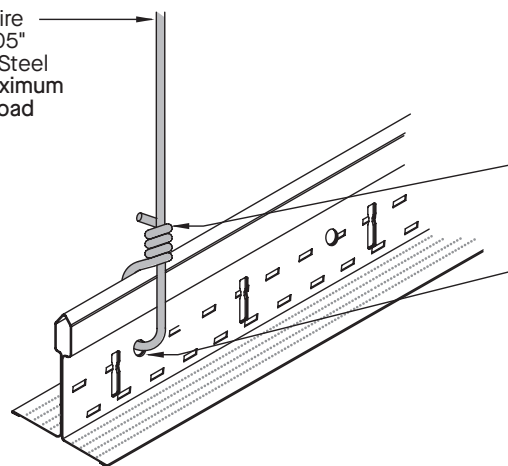

3 Turns in 3"
Per ASTM C 636

450 lbs. Pullout -
Hanger Wire Hole

NOTE: Per ASTM C754 wires
must be plumb and straight

STUCCO/PLASTER INSTALLATION AND DETAILS

STUCCO/PLASTER GRID SUSPENSION INSTALLATION

- 1 For wind speed less than 60 MPH, install main beams 48" O.C. For wind speed over 60 MPH, see page 9 for main beam spacing.
 - 2 Use either track positively attached, metal angle or main beam for isolation from wall. When located near salt water, use 9 gauge wire.
 - 3 Install cross tees 16" O.C.
 - 4 Install vertical brace at required locations for wind loading on suspension system. See chart page 9.
 - 5 Install substrate gypsum board (water resistant) with screw spacing 6" to 8" O.C. Cement board can also be used on exterior. Use lower RPM (1,000-2,500) screw gun to install cement board screws with intermittent pressure.
 - 6 Install finish system per manufacturers recommendation.
 - 7 Use plastic vented starter, stops or casing beads with holes to allow moisture to escape from system.
 - 8 Install vent strips where necessary in plenum to handle air pressure and moisture.
 - 9 Install both control joints and expansion joints to control movement in system, in accordance with ASTM C840.
 - 10 Synthetic bonding agents are the responsibility of each individual manufacturer of EIFS and is not the responsibility of the suspension system manufacturer.
 - 11 The suspension system manufacturer's responsibility is to furnish a smooth and level surface in accordance with C645 and C754 for the proper weight loading.
- For further information, contact your local representative or TechLine at 877 276 7876.

DETAILS OF STUCCO/PLASTER SYSTEMS

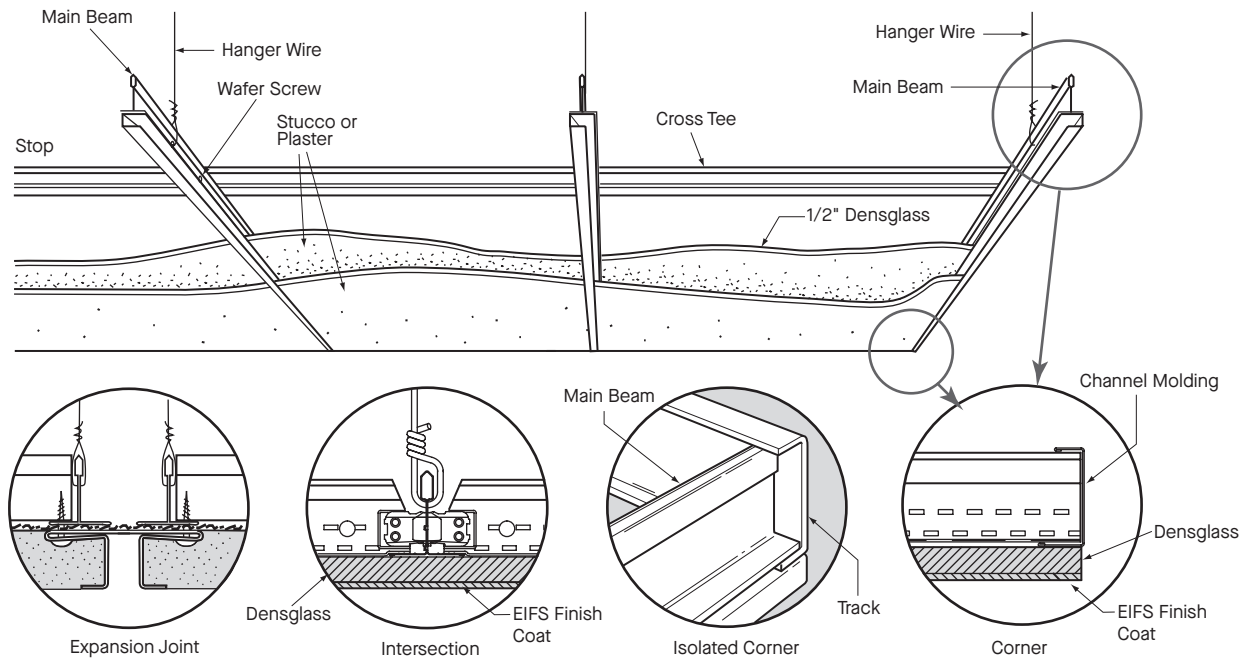

STUCCO/PLASTER GRID SUSPENSION INSTALLATION

Insulated

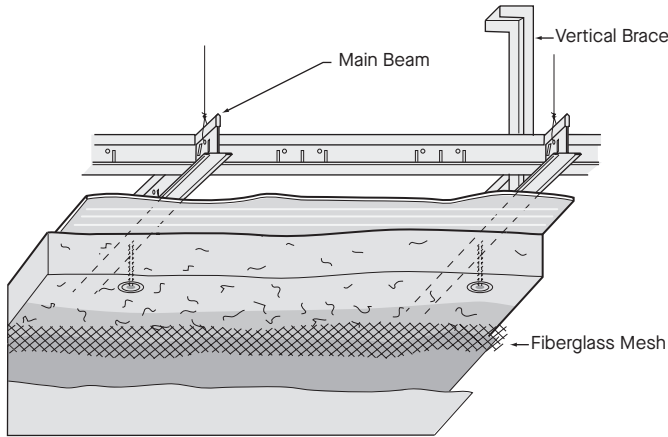

Uninsulated

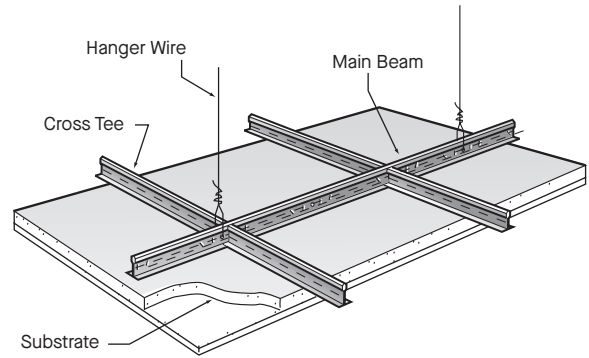

Vent Strip

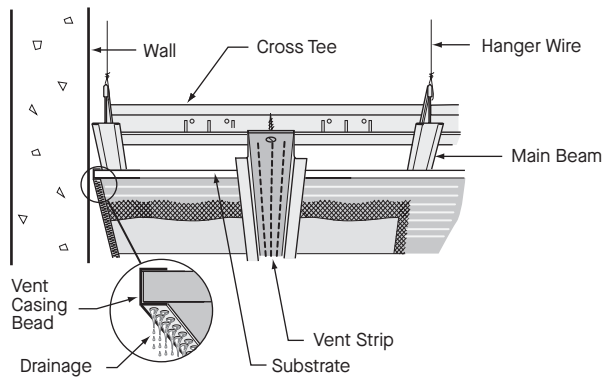

Control Joint

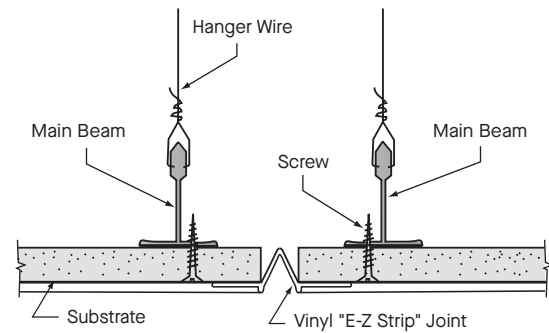

Non-Modular Cut and Screw

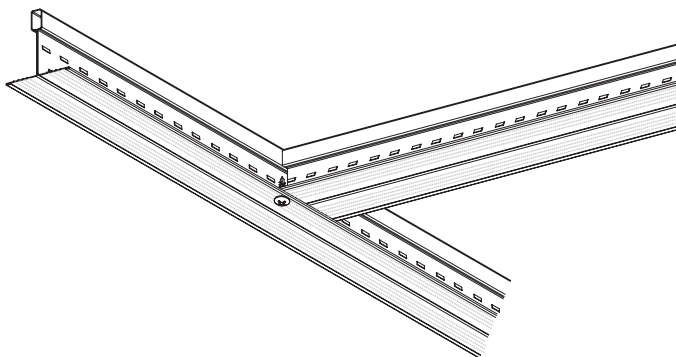

Exterior Wind Loaded (See chart on page 6)

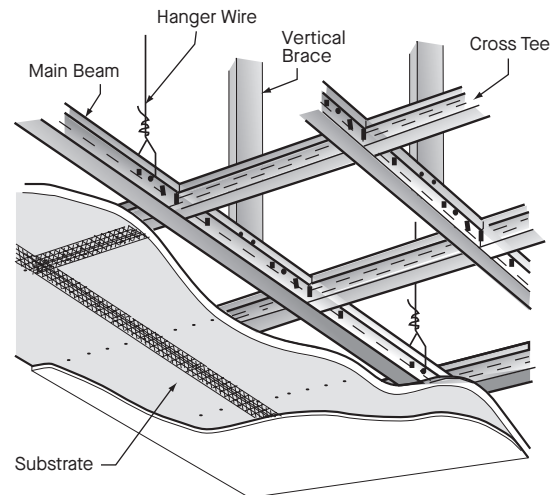

STUCCO/PLASTER INSTALLATION

DETAILS OF STUCCO/PLASTER SYSTEMS

Rock Lath and Plaster

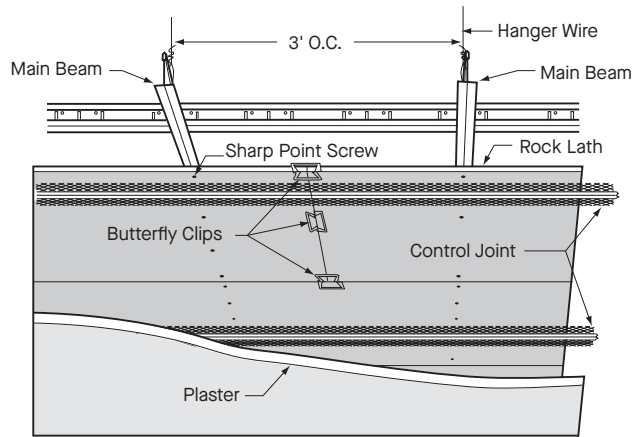

Security Metal Lath and Plaster

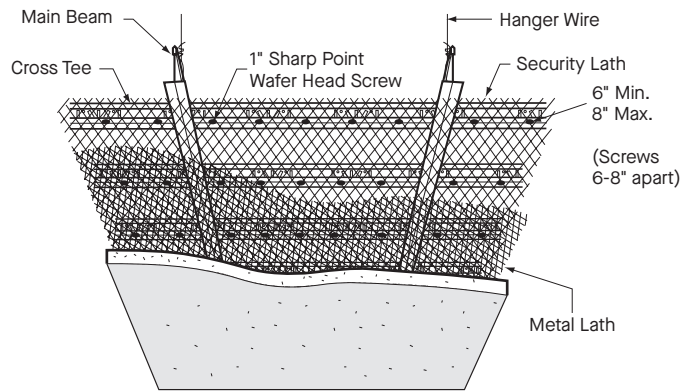

EIFS SYSTEM EXTERIOR WIND LOAD DESIGN FOR NORTH AMERICA

| Plenum Height (ft. - in.) | Design Wind Velocity (MPH) | Design Wind Pressure (PSF) | Compression Post Size (Inch) | Compression Post Gauge (Ga. No.) | Sheathing Membrane Substrate 5/8" Drywall Sheet Densglass Gold G-P | Compression Post Spacing (ft. - in.) | Main Runner Spacing (Inch) | Cross Tee Spacing (Inch) | Hanger Wire Spacing (ft. - in.) | Cross Tee Length (Feet) | Compression Post Load (Lbs.) |
|-------------------------------|----------------------------|----------------------------|------------------------------|----------------------------------|--|--------------------------------------|----------------------------|--------------------------|---------------------------------|-------------------------|------------------------------|
| 0 ↓ 6' *** | 15 | 0.507 | 2 1/2" CWN | 20 | 5/8" G.P. Densglass & 1/4"-3/8" EIFS | 4' - 2" | 48" | 16" | 4' | 4' | 18 |
| | 30 | 2.03 | 2 1/2" CWN | 20 | 5/8" G.P. Densglass & 1/4"-3/8" EIFS | 3' - 10" | 48" | 16" | 4' | 4' | 49 |
| | 45 | 4.56 | 2 1/2" CWN | 20 | 5/8" G.P. Densglass & 1/4"-3/8" EIFS | 3' - 6" | 48" | 16" | 4' | 4' | 96 |
| | 60 | 8.1 | 2 1/2" CWN | 20 | 5/8" G.P. Densglass & 1/4"-3/8" EIFS | 3' - 6" | 36" | 16" | 4' | 3' | 125 |
| | 90 | 18.24 | 2 1/2" CWN | 20 | 5/8" G.P. Densglass & 1/4"-3/8" EIFS | 2' - 9" | 36" | 16" | 3' | 3' | 229 |
| | 120 | 32.43 | 2 1/2" CWN | 20 | 5/8" G.P. Densglass & 1/4"-3/8" EIFS | 2' - 8" | 24" | 16" | 2' - 6" | 2' | 266 |
| | 140 | 44.14 | 2 1/2" CWN | 18 | 5/8" G.P. Densglass & 1/4"-3/8" EIFS | 2' - 4" | 24" | 16" | 2' - 6" | 2' | 331 |
| | 172 | 75 | 2 1/2" CSJ | 18 | See NOA 12-0314.05 Design | 2' | 24" | 16" | 2' | 2' | 445 |
| 6' 1" ↓ 10' 3" **** | 15 | 5.07 | 2 1/2" CSJ | 18 | 5/8" G.P. Densglass & 1/4"-3/8" EIFS | 4' - 2" | 48" | 16" | 4' | 4' | 18 |
| | 30 | 2.03 | 2 1/2" CSJ | 18 | 5/8" G.P. Densglass & 1/4"-3/8" EIFS | 3' - 10" | 48" | 16" | 4' | 4' | 49 |
| | 45 | 4.56 | 2 1/2" CSJ | 18 | 5/8" G.P. Densglass & 1/4"-3/8" EIFS | 3' - 6" | 48" | 16" | 4' | 4' | 96 |
| | 60 | 8.1 | 2 1/2" CSJ | 18 | 5/8" G.P. Densglass & 1/4"-3/8" EIFS | 3' - 6" | 36" | 16" | 4' | 3' | 125 |
| | 90 | 18.24 | 2 1/2" CSJ | 18 | 5/8" G.P. Densglass & 1/4"-3/8" EIFS | 2' - 9" | 36" | 16" | 3' | 3' | 229 |
| | 120 | 32.43 | 2 1/2" CSJ | 18 | 5/8" G.P. Densglass & 1/4"-3/8" EIFS | 2' - 8" | 24" | 16" | 2' - 6" | 2' | 266 |
| | 140 | 44.14 | 2 1/2" CSJ | 18 | 5/8" G.P. Densglass & 1/4"-3/8" EIFS | 2' - 4" | 24" | 16" | 2' - 6" | 2' | 331 |
| | 172 | 75 | 2 1/2" CSJ | 18 | See NOA 12-0314.05 Design | 2' | 24" | 16" | 2' | 2' | 445 |
| 10' 4" ↓ 15' 0" **** | 15 | 5.07 | 2 1/2" CSJ | 18 | 5/8" G.P. Densglass & 1/4"-3/8" EIFS | 4' - 2" | 48" | 16" | 4' | 4' | 18 |
| | 30 | 2.03 | 2 1/2" CSJ | 18 | 5/8" G.P. Densglass & 1/4"-3/8" EIFS | 3' - 10" | 48" | 16" | 4' | 4' | 49 |
| | 45 | 4.56 | 2 1/2" CSJ | 18 | 5/8" G.P. Densglass & 1/4"-3/8" EIFS | 3' - 6" | 48" | 16" | 4' | 4' | 96 |
| | 60 | 8.1 | 2 1/2" CSJ | 18 | 5/8" G.P. Densglass & 1/4"-3/8" EIFS | 3' - 6" | 36" | 16" | 4' | 3' | 125 |
| | 90 | 18.24 | 2 1/2" CSJ | 18 | 5/8" G.P. Densglass & 1/4"-3/8" EIFS | 2' - 9" | 36" | 16" | 3' | 3' | 229 |
| | 120 | 32.43 | 2 1/2" CSJ | 18 | 5/8" G.P. Densglass & 1/4"-3/8" EIFS | 2' - 8" | 24" | 16" | 2' - 6" | 2' | 266 |
| | 140 | 44.14 | 2 1/2" CSJ | 18 | 5/8" G.P. Densglass & 1/4"-3/8" EIFS | 2' - 4" | 24" | 16" | 2' - 6" | 2' | 331 |
| | 172 | 75 | 2 1/2" CSJ | 18 | See NOA 12-0314.05 Design | 2' | 24" | 16" | 2' | 2' | 445 |
| 15' 1" ↓ 20' 0" **** | 15 | 5.07 | 3 5/8" CSJ | 18 | 5/8" G.P. Densglass & 1/4"-3/8" EIFS | 4' - 2" | 48" | 16" | 4' | 4' | 18 |
| | 30 | 2.03 | 3 5/8" CSJ | 18 | 5/8" G.P. Densglass & 1/4"-3/8" EIFS | 3' - 10" | 48" | 16" | 4' | 4' | 49 |
| | 45 | 4.56 | 3 5/8" CSJ | 18 | 5/8" G.P. Densglass & 1/4"-3/8" EIFS | 3' - 6" | 48" | 16" | 4' | 4' | 96 |
| | 60 | 8.1 | 3 5/8" CSJ | 18 | 5/8" G.P. Densglass & 1/4"-3/8" EIFS | 3' - 6" | 36" | 16" | 4' | 3' | 125 |
| | 90 | 18.24 | 3 5/8" CSJ | 18 | 5/8" G.P. Densglass & 1/4"-3/8" EIFS | 2' - 9" | 36" | 16" | 3' | 3' | 229 |
| | 120 | 32.43 | 3 5/8" CSJ | 18 | 5/8" G.P. Densglass & 1/4"-3/8" EIFS | 2' - 8" | 24" | 16" | 2' - 6" | 2' | 266 |
| | 140 | 44.14 | 3 5/8" CSJ | 18 | 5/8" G.P. Densglass & 1/4"-3/8" EIFS | 2' - 4" | 24" | 16" | 2' - 6" | 2' | 331 |
| | 172 | 75 | 3 5/8" CSJ | 18 | See NOA 12-0314.05 Design | 2' | 24" | 16" | 2' | 2' | 445 |
| 172 | 75 | 3 5/8" CSJ | 18 | See NOA 12-0314.04 Design | 2' - 6" | 36" | 16" | 2' - 6" | 3' | 565 | |

Ceiling System = HD 8906-G90 Main Runner 12 ft. / XL 8945P-G90 Cross Runner 4 ft. / XL 7936-G90 Cross Runner 3 ft. / XL 8926-G90 Cross Runner 2 ft. / #9 Ga. H.D.G. Hanger Wire

- * Note 1-1/2" 16ga. U-Channel Bridging required at Mid Span for 10'4" up to 15'0".
- ** Note 1-1/2" 16ga. U-Channel Bridging required at 1/3rd Points for 15'1" up to 20'0".
- *** Compression Post and Ceiling system tested at the plenum design depth shown here for positive and negative wind speed pressure loads as listed.
- **** Compression Post Assemblies at this plenum design depth calculated by Dietrich Design Group.

For building heights over 20 feet refer to ASCE 7-10 chapter 6 Wind Loads Non-Impact Miami/Dade County EIFS Exterior Ceiling Design NOA 12-0314.05 Hurricane Zone Approved.

Impact Rated EIFS Exterior Ceiling Design with 5/8" F/R plywood added to membrane Miami/Dade County See NOA 12-0314.04 Hurricane Zone Approved.Stud Products and Properties Based on Dietrich Industries Inc.

CONTROL JOINTS / EXPANSION JOINTS

Control joints minimize cracking caused by stresses in the surface material attached to a metal suspension system. Materials have different rates of expansion and control joints are placed 35' to 50' apart to control bucking and cracking of surface. Control joints are also used to minimize stresses in monolithic ceiling membrane that occur at columns, access doors, light fixtures, inside and outside corners and other unusual penetrations in ceilings. Ceiling expansion joints are installed to separate the metal suspension system when expansion joints occur in buildings, ceiling span is over 100' or when metal changes direction. Expansion joints are required to separate a system in T, H, L, and U or Circle shaped buildings to eliminate cracking from expansion. Both expansion and control joints look similar but perform different functions.

MEMBRANE LOAD VALUES

| Component Combinations | Maximum Load in lbs./ft. ² at Hanger Wire/Cross Tee Spacing | |
|-----------------------------------|--|-------|
| | 36"/ 16" | |
| | L/240 | L/360 |
| HD8906/XL7936G90 (mains 36" O.C.) | 21.77 | 14.51 |
| HD8906/XL8926 (mains 24" O.C.) | 26.13 | 21.77 |

WIND LOAD BRACING

EXTERIOR WIND LOAD BRACING TO CONCRETE SLAB

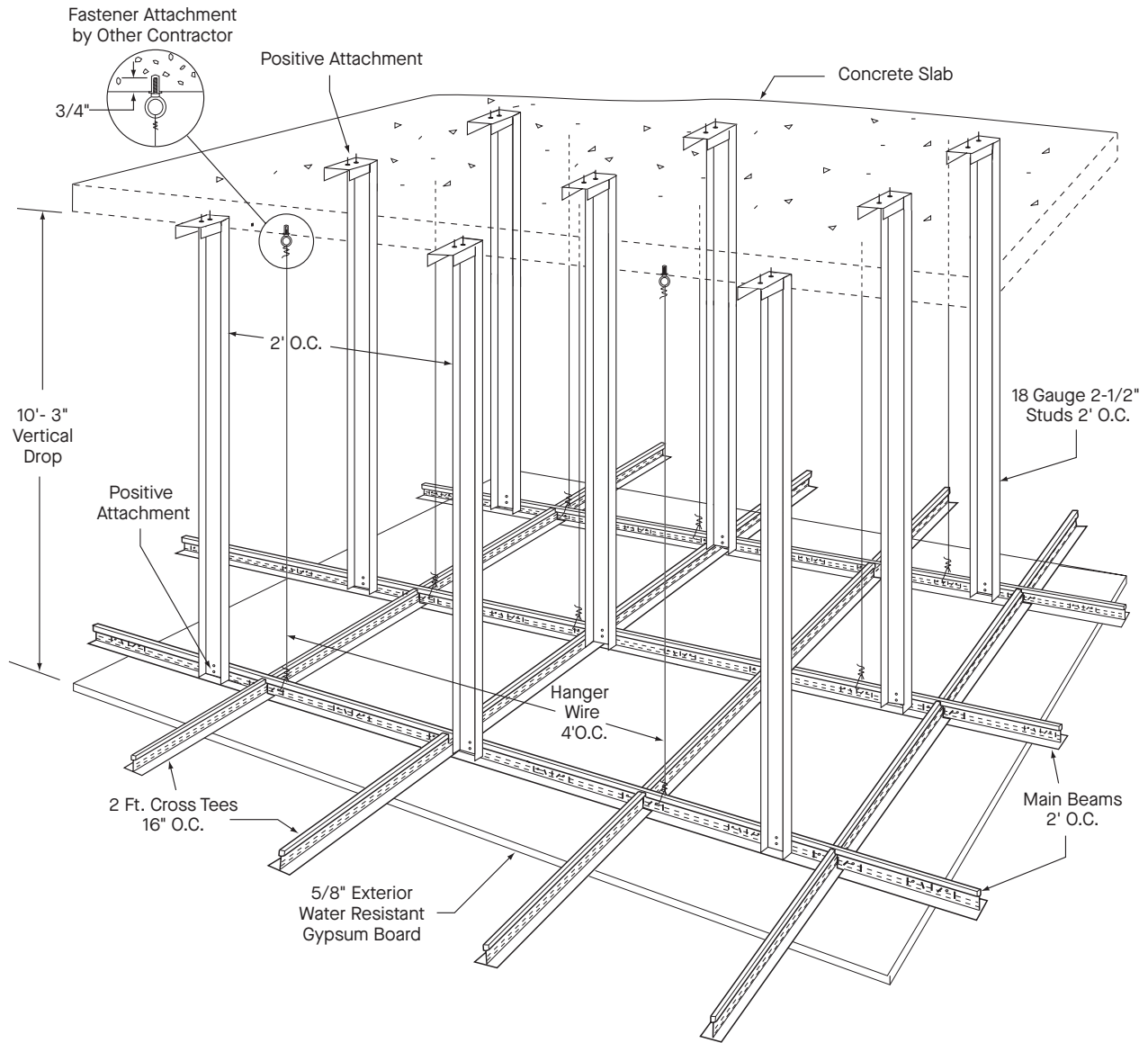

NOTES

- 1 Positive attach with #10 -16 screw – clip to stud.
- 2 Positive attach with Clip to Bar Joist with 2 .145" Dia. x 1/2" long.
- 3 Screws: #10 - 16 TEKS/ 3 Buildex or equal.
- 4 Power activated Fasteners: .145 Dia. x 1/2" long (X-DNI) Hilti pins.
- 5 Clips: All Clips to be made of 50 KSI material. Spans up to 70" use angle 2" x 5" x 12 gauge x 0-4" long. Spans 72" x 120" use angle 2" x 5" x 10 gauge x 0-5" long. For studs up to 4", use 3" flange in lieu of 5".
- 6 All spans based on single span.
- 7 Wind load – 75 PSF
- 8 Dead load – 10 PSF
- 9 Spans of 120" require bridging on top flange at midspan. Use 1-1/2 CRC 16 gauge attached with (1) #10 - 16 to top flange.
- 10 In some cases, angles may need to be welded to structure.

EXTERIOR WIND LOAD BRACING TO METAL BAR JOISTS

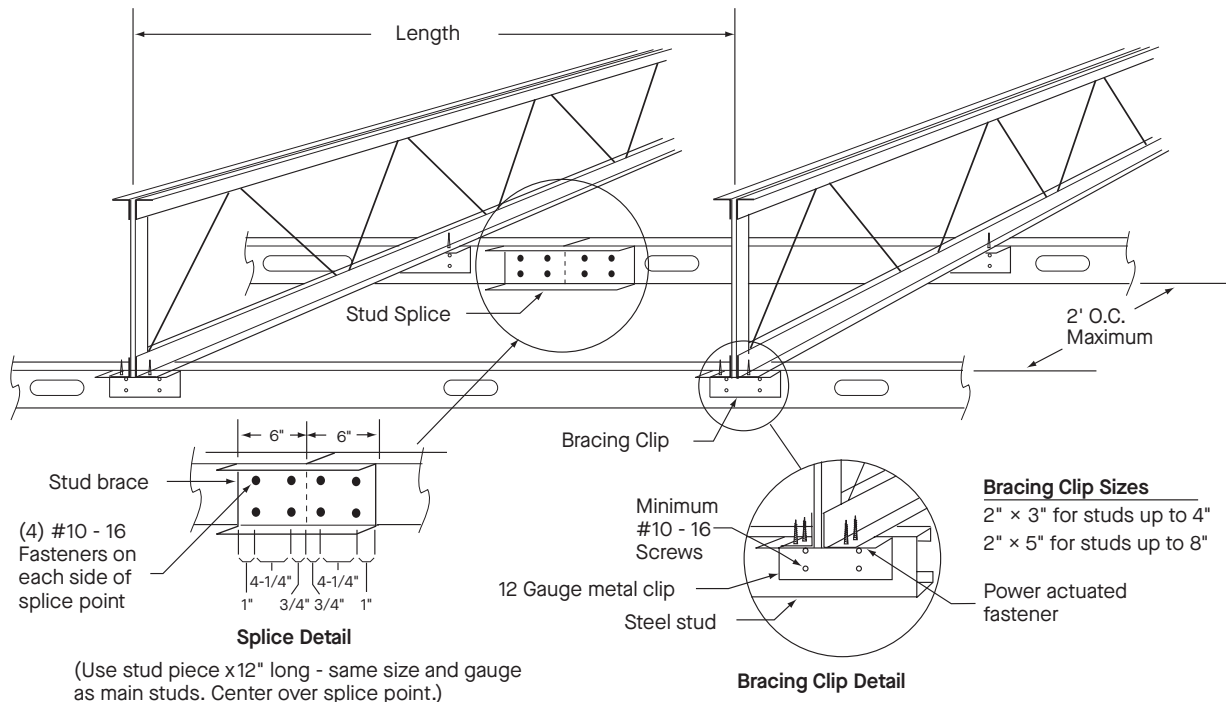

Steel Stud Bracing 2' O.C. Astmc - 645

| Span Length | 3-5/8" | Gauge | 4" | Gauge | 6" | Gauge | 8" | Gauge | |
|-------------|--|-------|---------|-------|---------|-------|---------|---------|----|
| 48" | 362 - CSJ | 20 | | | | | | | |
| 54" | 362 - CSJ | 20 | 4 - CSJ | 20 | | | | | |
| 60" | 362 - CSJ | 18 | 4 - CSJ | 18 | | | | | |
| 66" | 362 - CSJ | 16 | 4 - CSJ | 16 | | | | | |
| 70" | 362 - CSJ | 14 | | | 6 - CSJ | 20 | | | |
| 72" | | | 4 - CSJ | 14 | | | | | |
| 76" | | | | | 6 - CSJ | 18 | | | |
| 80" | | | | | | | 8 - CSJ | 18 | |
| 82" | | | | | 6 - CSJ | 16 | | | |
| 86" | | | | | | | 8 - CSJ | 18 | |
| 88" | | | | | 6 - CSJ | 14 | | | |
| 92" | | | | | | | 8 - CSJ | 16 | |
| 96" | | | | | | | 8 - CSJ | 14 | |
| 120" | (For 120" Length Bridging Required @ Midspan (See Note 9)) | | | | | | | 8 - CSJ | 16 |

NOTES

- Positive attach with #10 -16 screw – clip to stud.
- Positive attach with Clip to Bar Joist with 2 .145" Dia. x 1/2" long.
- Screws: #10 - 16 TEKS/ 3 Buildex or equal.
- Power activated Fasteners: .145 Dia. x 1/2" long (X-DNI) Hilti pins.
- Clips: All Clips to be made of 50 KSI material. Spans up to 70" use angle 2" x 5" x 12 gauge x 0-4" long. Spans 72" x 120" use angle 2" x 5" x 10 gauge x 0-5" long. For studs up to 4", use 3" flange in lieu of 5".
- All spans based on single span.
- Wind load – 75 PSF
- Dead load – 10 PSF
- Spans of 120" require bridging on top flange at midspan. Use 1-1/2 CRC 16 gauge attached with (1) #10 - 16 to top flange.
- In some cases, angles may need to be welded to structure.

WIND LOAD BRACING

EXTERIOR WIND LOAD BRACING TO CONCRETE SLAB

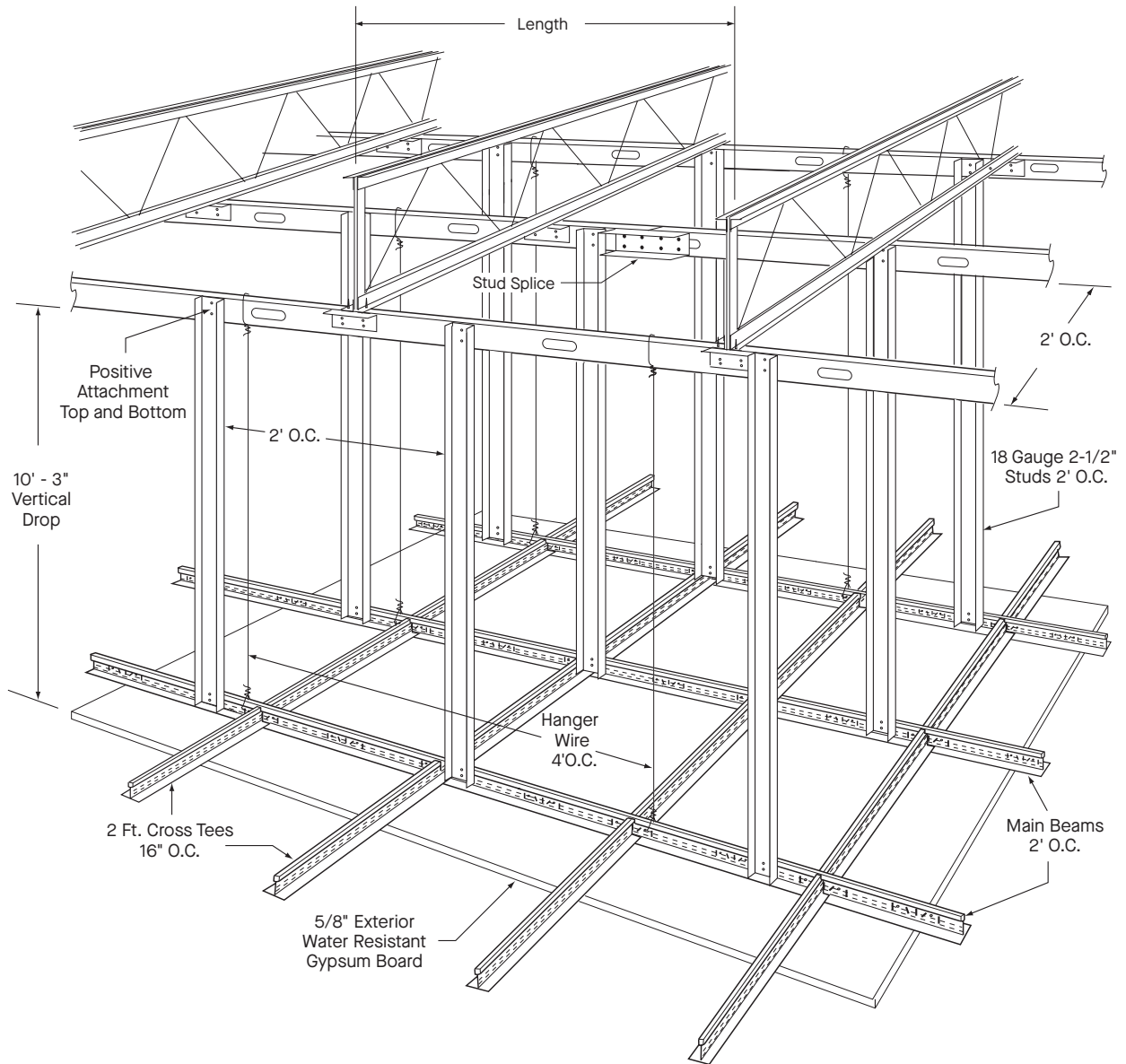

NOTES

- 1 Positive Attachment Top and Bottom.
- 2 22 Gauge 2-1/2" Studs 2' O.C.
- 3 Main Beams 2' O.C. / Cross Tees 16" O.C. 2' Long.
- 4 Hanger Wire 4' O.C.
- 5 Vertical Drop 0 - 6' Minimum 22 Gauge.
Not shown on drawing. (See Chart)

EXTERIOR WIND LOAD BRACING TO METAL BAR JOISTS

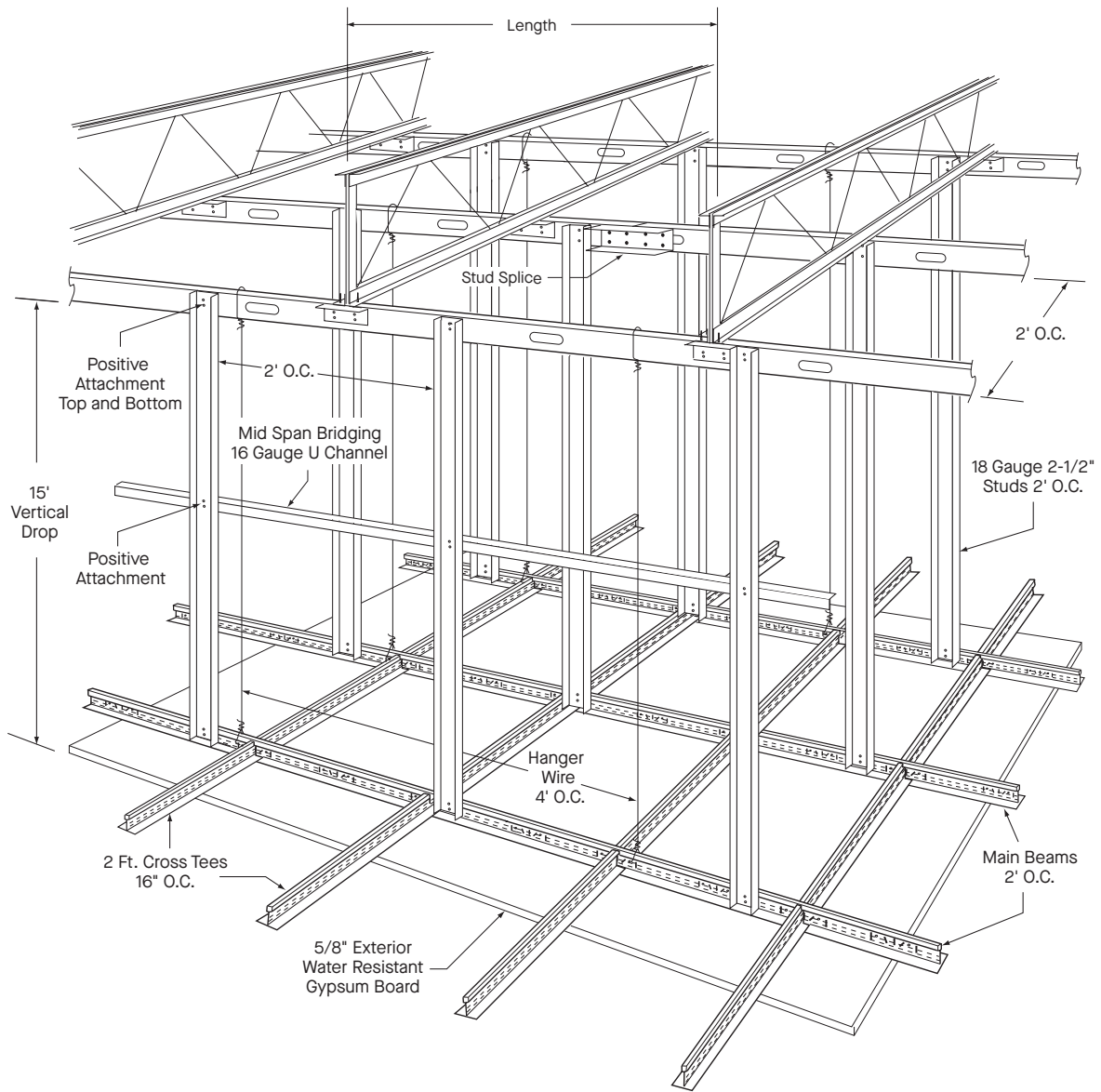

NOTES

- 1 1-1/2 #16 Gauge U Channel Bracing Required at Mid Span for 10' – 15' Vertical Drop.
- 2 Positive Attachment Top and Bottom.
- 3 18 Gauge 2-1/2" Stud 2' O.C.
- 4 Main Beams 2' O.C. / Cross Tees 16" O.C 2' Long.
- 5 Hanger Wire 4' O.C.

WIND LOAD BRACING

EXTERIOR WIND LOAD BRACING TO METAL BAR JOISTS

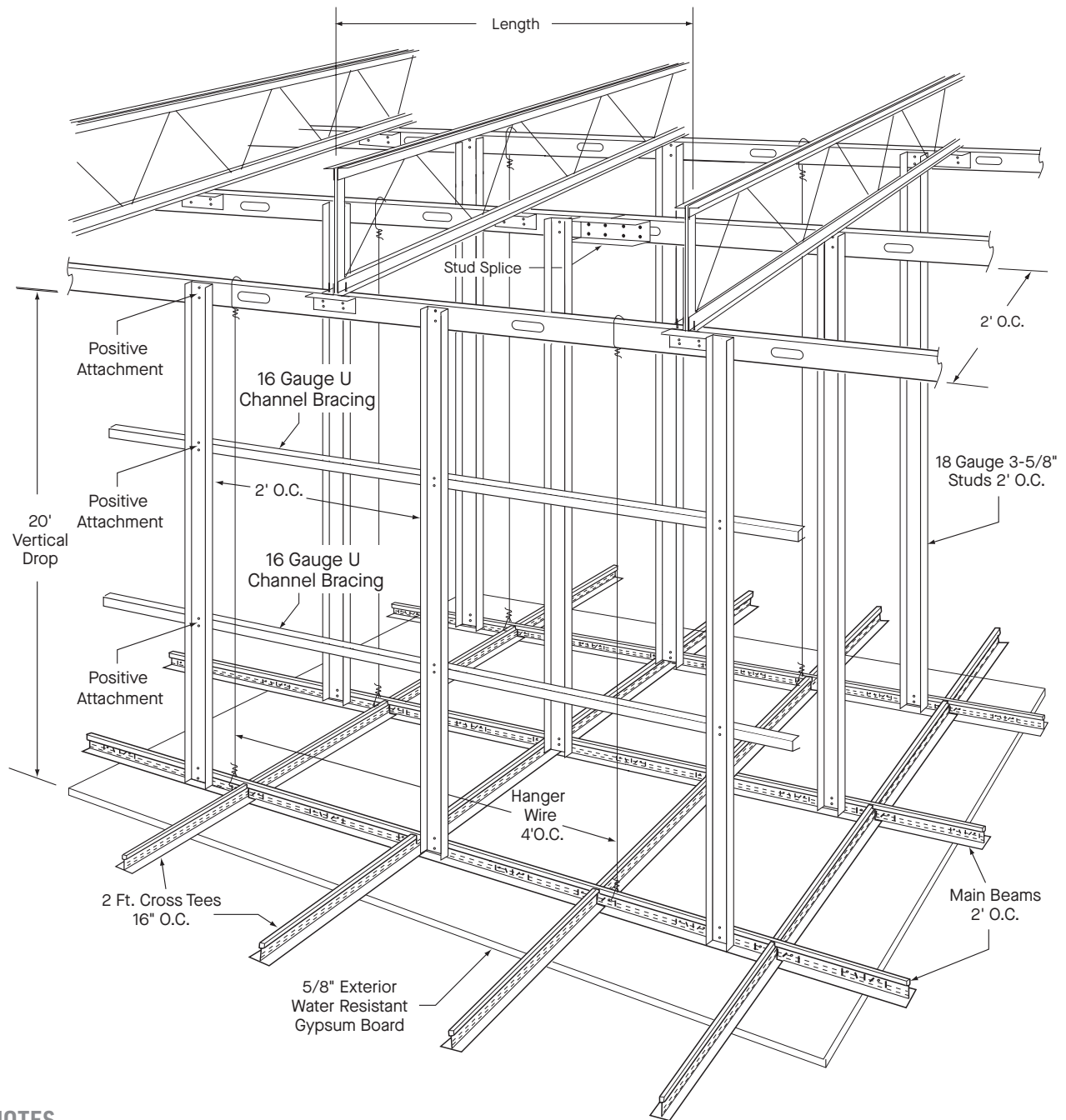

NOTES

- 1 1-1/2 #16 Gauge U Channel Bracing Required at 1/3 Points.
- 2 Positive Attachment Top and Bottom.
- 3 18 Gauge 3-5/8" Studs 2' O.C.
- 4 Main Beams 2' O.C. / Cross Tees 16" O.C 2' Long.
- 5 Hanger Wire 4' O.C.

ESTABLISHING AN ARC

- 1 Draw radius on template (plywood, gypsum board, etc.).
- 2 Establish a center line.
- 3 Mark 2' increments on line perpendicular to center line.
- 4 At 2' marks, identify points of arc below perpendicular line (maintain consistent spacing of point). See radius charts on page 17.
- 5 Connect points to form a smooth arc.

Example: 43' arc using chart on page 17

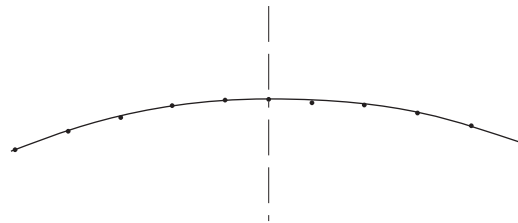
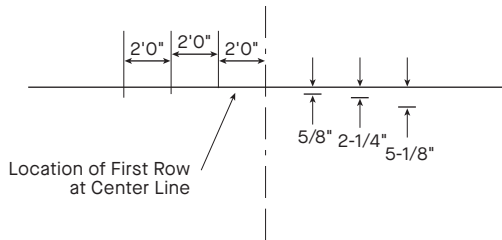

COMPLETING THE TEMPLATE - OPTION 1

- 1 Cut along the arc and remove section of template.
- 2 Cut main beam as required and position along the cut radius on the template (use chart on page 17).
- 3 Screw RC2 clips to faceted main beam at all knockout locations. *
- 4 On the template, mark a rout location reference point to maintain consistent rout location.

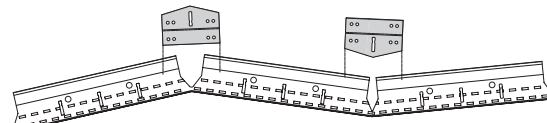

* RC2 Clip placement
 Vaults – Cross tee placement in routs between cuts
 Valleys – Cross tee lock into rout on RC2 clip (tight radius installations may require bending up of the flange at ends of cross tees)
 Note: Screw RC2 to cavity side of web

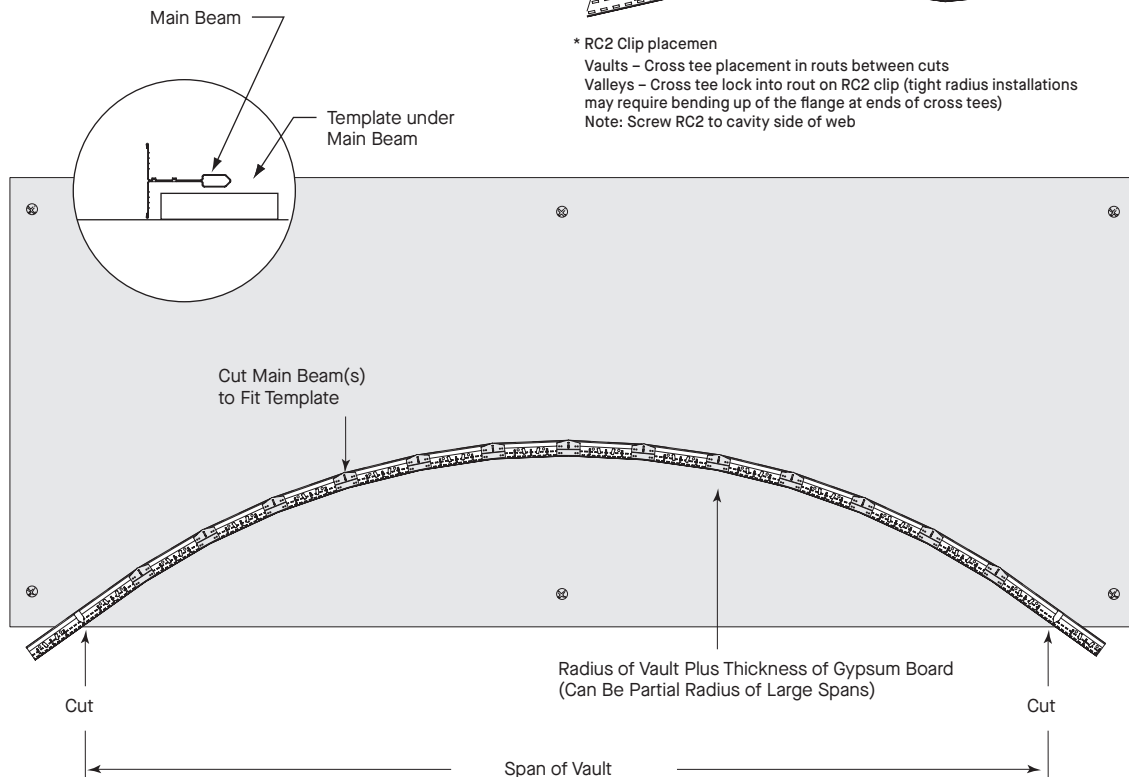

MAKING A TEMPLATE

COMPLETING THE TEMPLATE - OPTION 2

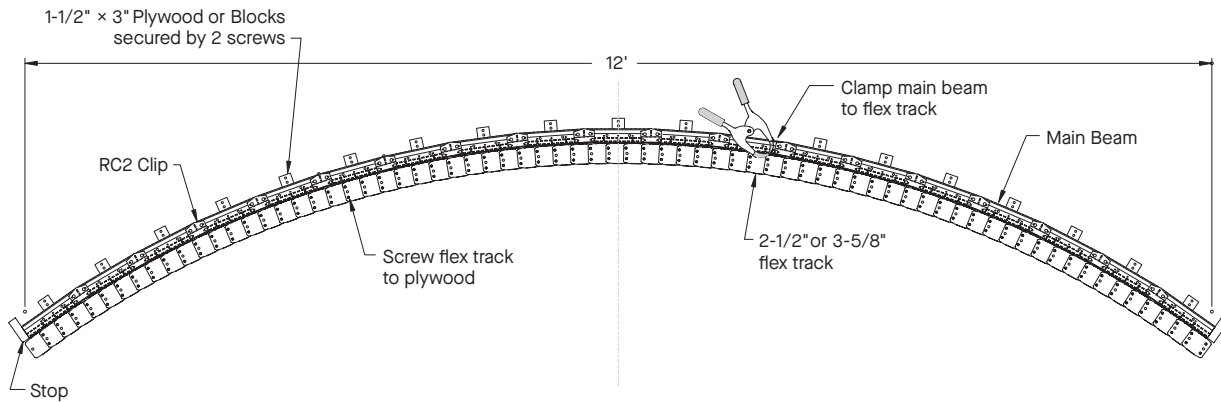

- 1 Draw radius on board.
- 2 Screw flex track to board along radius line.
- 3 Cut main beams as required and position along the flex track on the template.
- 4 Screw RC2* clips to faceted main beam at all knockout locations.
- 5 On the template, mark a rout location reference point to maintain consistent rout location.

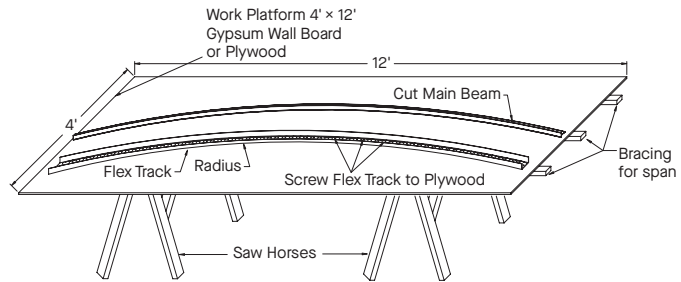

Contractors' efficiency and understanding of the suspended grid system construction provides performance benefits and cost savings.

- An unlimited range of vaults and valleys can be constructed using faceted main beams made on the job to meet design needs.
- Single and multiple curved ceilings can be framed quickly and easily.

* Screw RC2 on cavity side of web

RADIUS DIMENSIONS

| Radius Dimension | | 10' 0" | 11' 0" | 12' 0" | 13' 0" | 14' 0" | 15' 0" | 16' 0" | 17' 0" | 18' 0" | 19' 0" | 20' 0" | 21' 0" | 22' 0" | 23' 0" | 24' 0" | |
|--------------------------------|---------|----------|----------|----------|----------|----------|----------|----------|----------|-----------|----------|----------|---------|----------|----------|----------|------|
| 2' Increments from Center Line | 2' | 2" | 2-1/4" | 2" | 1-7/8" | 1-3/4" | 1-5/8" | 1-1/2" | 1-1/2" | 1-3/8" | 1-1/4" | 1-1/4" | 1-1/8" | 1-1/8" | 1-1/8" | 1" | |
| | 4' | 10" | 9-1/8" | 8-1/4" | 7-5/8" | 7" | 6-1/2" | 6-1/8" | 5-3/4" | 5-3/8" | 5-1/8" | 4-7/8" | 4-5/8" | 4-3/8" | 4-1/4" | 4" | |
| | 6' | 2' 0" | 1'9-3/8" | 1'7-3/8" | 1'5-5/8" | 1'4-1/4" | 1'3" | 1'2" | 1'1-1/8" | 1'0-3/8" | 11-3/4" | 11-1/8" | 10-1/2" | 10" | 9-5/8" | 9-1/8" | |
| | 8' | 4' 0" | 3'5-5/8" | 3'0-3/4" | 2'9-1/8" | 2'6-1/8" | 2'3-3/4" | 2'1-3/4" | 2' 0" | 1'10-1/2" | 1'9-1/4" | 1'8-1/8" | 17" | 1'6-1/8" | 1'5-1/4" | 1'4-1/2" | |
| | | 25' 0" | 26' 0" | 27' 0" | 28' 0" | 29' 0" | 30' 0" | 31' 0" | 32' 0" | 33' 0" | 34' 0" | 35' 0" | 36' 0" | 37' 0" | 38' 0" | 39' 0" | |
| | 2' | 1" | 1" | 7/8" | 7/8" | 7/8" | 7/8" | 3/4" | 3/4" | 3/4" | 3/4" | 3/4" | 3/4" | 3/4" | 5/8" | 5/8" | 5/8" |
| | 4' | 3-7/8" | 3-3/4" | 35/8" | 3-1/2" | 3-3/8" | 3-1/4" | 3-1/8" | 3" | 3" | 2-7/8" | 2-3/4" | 2-3/4" | 2-5/8" | 2-5/8" | 2-1/2" | |
| | 6' | 8-3/4" | 8-1/2" | 81/2" | 7-7/8" | 7-1/2" | 7-1/4" | 7-1/8" | 6-7/8" | 6-5/8" | 6-3/8" | 6-1/4" | 6-1/8" | 5-7/8" | 5-3/4" | 5-5/8" | |
| | 8' | 1'3-3/4" | 1'3-1/8" | 1'25/8" | 1'2" | 1'2-1/2" | 1'1-1/8" | 1'0-5/8" | 1'0-1/4" | 11-1/2" | 11-1/2" | 11-1/8" | 10-7/8" | 10-1/2" | 10-1/4" | 10" | |
| | | 40' 0" | 41' 0" | 42' 0" | 43' 0" | 44' 0" | 45' 0" | 46' 0" | 47' 0" | 48' 0" | 49' 0" | 50' 0" | 51' 0" | 52' 0" | 53' 0" | 54' 0" | |
| | 2' | 5/8" | 5/8" | 5/8" | 5/8" | 5/8" | 5/8" | 1/2" | 1/2" | 1/2" | 1/2" | 1/2" | 1/2" | 1/2" | 1/2" | 1/2" | |
| | 4' | 2-3/8" | 2-3/8" | 2-3/8" | 2-1/4" | 2-1/8" | 2-1/8" | 2-1/8" | 2-1/8" | 2" | 2" | 2" | 1-7/8" | 1-7/8" | 1-3/4" | 1-3/4" | |
| | 6' | 5-1/2" | 5-3/8" | 5-1/4" | 5-1/8" | 5" | 4-7/8" | 4-3/4" | 4-5/8" | 4-1/2" | 4-1/2" | 4-3/8" | 4-1/4" | 4-1/4" | 4-1/4" | 4" | |
| | 8' | 9-3/4" | 9-1/2" | 9-1/4" | 9" | 8-7/8" | 8-5/8" | 8-1/2" | 8-1/4" | 8-1/8" | 7-7/8" | 7-3/4" | 7-5/8" | 7-1/2" | 7-3/8" | 7-1/8" | |
| | | 55' 0" | 56' 0" | 57' 0" | 58' 0" | 59' 0" | 60' 0" | 61' 0" | 62' 0" | 63' 0" | 64' 0" | 65' 0" | 66' 0" | 67' 0" | 68' 0" | 69' 0" | |
| | 2' | 1/2" | 1/2" | 1/2" | 1/2" | 1/2" | 3/8" | 3/8" | 3/8" | 3/8" | 3/8" | 3/8" | 3/8" | 3/8" | 3/8" | 3/8" | |
| | 4' | 1-3/4" | 1-3/4" | 1-3/4" | 1-3/4" | 1-5/8" | 1-5/8" | 1-5/8" | 1-5/8" | 1-1/2" | 1-1/2" | 1-1/2" | 1-1/2" | 1-1/2" | 1-1/2" | 1-3/8" | |
| | 6' | 4" | 3-7/8" | 3-7/8" | 3-3/4" | 3-3/4" | 3-5/8" | 3-5/8" | 3-1/2" | 3-1/2" | 3-3/8" | 3-3/8" | 3-1/4" | 3-1/4" | 3-1/4" | 3-1/8" | |
| | 8' | 7" | 6-7/8" | 6-3/4" | 6-5/8" | 6-5/8" | 6-1/2" | 6-3/8" | 6-1/4" | 6-1/8" | 6" | 6" | 5-7/8" | 5-3/4" | 5-3/4" | 5-5/8" | |
| | | 70' 0" | 71' 0" | 72' 0" | 73' 0" | 74' 0" | 75' 0" | 76' 0" | 77' 0" | 78' 0" | 79' 0" | 80' 0" | 81' 0" | 82' 0" | 83' 0" | 84' 0" | |
| | 2' | 3/8" | 3/8" | 3/8" | 3/8" | 3/8" | 3/8" | 3/8" | 3/8" | 3/8" | 3/8" | 3/8" | 3/8" | 3/8" | 3/8" | 3/8" | |
| | 4' | 1-3/8" | 1-3/8" | 1-3/8" | 1-3/8" | 1-3/8" | 1-1/4" | 1-1/4" | 1-1/4" | 1-1/4" | 1-1/4" | 1-1/4" | 1-1/4" | 1-1/4" | 1-1/4" | 1-1/8" | |
| | 6' | 3-1/8" | 3-1/8" | 3" | 3" | 3" | 2-7/8" | 2-7/8" | 2-7/8" | 2-3/4" | 2-3/4" | 2-3/4" | 2-3/4" | 2-5/8" | 2-5/8" | 2-5/8" | |
| | 8' | 5-1/2" | 5-1/2" | 5-3/8" | 5-1/4" | 5-1/4" | 5-1/8" | 5-1/8" | 5" | 5" | 4-7/8" | 4-7/8" | 4-3/4" | 4-3/4" | 4-5/8" | 4-5/8" | |
| | 85' 0" | 86' 0" | 87' 0" | 88' 0" | 89' 0" | 90' 0" | 91' 0" | 92' 0" | 93' 0" | 94' 0" | 95' 0" | 96' 0" | 97' 0" | 98' 0" | 99' 0" | | |
| 2' | 3/8" | 1/4" | 1/4" | 1/4" | 1/4" | 1/4" | 1/4" | 1/4" | 1/4" | 1/4" | 1/4" | 1/4" | 1/4" | 1/4" | 1/4" | | |
| 4' | 1-1/8" | 1-1/8" | 1-1/8" | 1-1/8" | 1-1/8" | 1-1/8" | 1-1/8" | 1-1/8" | 1-1/8" | 1" | 1" | 1" | 1" | 1" | 1" | | |
| 6' | 2-5/8" | 2-1/2" | 2-1/2" | 2-1/2" | 2-1/2" | 2-3/8" | 2-3/8" | 2-3/8" | 2-3/8" | 2-3/8" | 2-1/4" | 2-1/4" | 2-1/4" | 2-1/4" | 2-1/4" | | |
| 8' | 4-1/2" | 4-1/2" | 4-1/2" | 4-3/8" | 4-3/8" | 4-1/4" | 4-1/4" | 4-1/4" | 4-1/8" | 4-1/8" | 4-1/8" | 4" | 4" | 4" | 3-7/8" | | |
| | 100' 0" | 105' 0" | 110' 0" | 115' 0" | 120' 0" | 125' 0" | 130' 0" | 135' 0" | 140' 0" | 145' 0" | 150' 0" | 155' 0" | 160' 0" | 165' 0" | 170' 0" | | |
| 2' | 1/4" | 1/4" | 1/4" | 1/4" | 1/4" | 1/4" | 1/4" | 1/4" | 1/4" | 1/4" | 1/4" | 1/4" | 1/8" | 1/8" | 1/8" | | |
| 4' | 1" | 1" | 7/8" | 7/8" | 7/8" | 3/4" | 3/4" | 3/4" | 3/4" | 3/4" | 3/4" | 5/8" | 5/8" | 5/8" | 5/8" | | |
| 6' | 2-1/4" | 2-1/8" | 2" | 1-7/8" | 1-7/8" | 1-3/4" | 1-3/4" | 1-5/8" | 1-5/8" | 1-1/2" | 1-1/2" | 1-3/8" | 1-3/8" | 1-3/8" | 1-1/4" | | |
| 8' | 3-7/8" | 3-3/4" | 3-1/2" | 3-3/8" | 3-1/4" | 3-1/8" | 3" | 2-7/8" | 2-3/4" | 2-3/4" | 2-5/8" | 2-1/2" | 2-3/8" | 2-3/8" | 2-1/4" | | |
| | 175' 0" | 180' 0" | 185' 0" | 190' 0" | 195' 0" | 200' 0" | 210' 0" | 220' 0" | 230' 0" | 240' 0" | 250' 0" | | | | | | |
| 2' | 1/8" | 1/8" | 1/8" | 1/8" | 1/8" | 1/8" | 1/8" | 1/8" | 1/8" | 1/8" | 1/8" | | | | | | |
| 4' | 5/8" | 5/8" | 1/2" | 1/2" | 1/2" | 1/2" | 1/2" | 1/2" | 3/8" | 3/8" | 3/8" | | | | | | |
| 6' | 1-1/4" | 1-1/4" | 1-1/4" | 1-1/8" | 1-1/8" | 1-1/8" | 1" | 1" | 1" | 7/8" | 7/8" | | | | | | |
| 8' | 2-1/4" | 2-1/8" | 2-1/8" | 2" | 2" | 2" | 1-7/8" | 1-3/4" | 1-5/8" | 1-5/8" | 1-1/2" | | | | | | |

NEXT STEPS

877 276-7876

Customer Service Representatives
7:45 a.m. to 5:00 p.m. EST
Monday through Friday

TechLine – Technical information, detail drawings, CAD design assistance, installation information, other technical services – 8:00 a.m. to 5:30 p.m. EST, Monday through Friday. FAX 800 572 8324 or email: techline@armstrongceilings.com

armstrongceilings.com/commercial

Latest product news

Standard and custom product information

Online catalog

CAD, Revit®, SketchUp® files

A Ceiling for Every Space® Visual Selection Tool

Product literature and samples – express service or regular delivery

Contacts – reps, where to buy, who will install



armstrongceilings.com/savingscalc

The Armstrong Time, Material & Labor Savings Calculators are here to help you save vs. traditional construction methods.

Just plug in your job specific details and receive a complete dashboard with side-by-side comparisons, solution benefits, details, and photos that can be used on your next project or shared with a project resource.

Visit the link above to start saving time and money today!

