

# Tips for Ceiling Installers



## Before You Start

**Tip 1:** Allowing panels and tiles to adjust to the job site .....2

## Ceiling Grid—Wall Molding

**Tip 2:** Leveling wall molding .....2

**Tip 3:** Installing wall molding on drywall .....2

**Tip 4:** Installing wall molding on solid or concrete walls .....2

**Tip 5:** Installing wall molding along an uneven wall surface.....2

## Ceiling Grid—Main Beams and Cross Tees

**Tip 6:** Choosing your hanger wire .2

**Tip 7:** Bending hanger wires .....2

**Tip 8:** Supporting the main beam .2

**Tip 9:** Squaring the grid .....3

## Easy Up® Track

**Tip 10:** Installing Easy Up Track .....3

## Tile Installation Using the Ashlar Method

**Tip 11:** Using the Easy Up system ..4

## Overhead Support Beams and Ducts

**Tip 12:** Boxing around overhead ducts and beams.....5

**Tip 13:** Using grid to box around obstructions.....5

## Support Columns

**Tip 14:** Boxing in columns with a suspended ceiling.....6

**Tip 15:** Installing panels around columns, pipes, vents and posts .....6

## Windows

**Tip 16:** Boxing in basement windows .....6

**Tip 17:** Installing decorative molding on boxed-in area.....7

## Ceiling Borders—Panels

**Tip 18:** Figuring borders on scored panels or panels with 12" × 12" patterns .....7

**Tip 19:** Cutting “recessed grid” ceiling border panels .....8

## Replacement—Tiles

**Tip 20:** Replacing damaged tiles using the Easy Up Installation System .....8

## Lighting

**Tip 21:** Hanging 2' × 4' lights.....9

**Tip 22:** Installing recessed lighting in a tile ceiling .....9

**Tip 23:** Installing recessed lighting in a suspended ceiling.....9

**Tip 24:** Installing surface-mounted lighting in a tile ceiling .....10

## Ceiling Fans

**Tip 25:** Mounting a ceiling fan in a tile ceiling.....10

## Vents and Recessed Fans

**Tip 26:** Mounting ceiling vents ..... 10

## Cathedral Ceilings

**Tip 27:** Installing WoodHaven™ planks on a cathedral ceiling ..... 10

**Tip 28:** Installing molding or trim between a suspended panel cathedral ceiling and wall .....12

## Insulation

**Tip 29:** Installing insulation ..... 12

## Miscellaneous

**Tip 30:** Installing tile where kitchen cabinet doors are close to the ceiling ..... 12

**Tip 31:** Removing dirt from tile and panel surfaces..... 12



# Tips for Ceiling Installers



## Before You Start

### Tip 1: Allowing panels and tiles to adjust to the job site

Remove tiles, panels or planks from the cartons 24 hours before installation and allow them to adjust to normal interior conditions of the area where installation will take place. Acceptable temperature and humidity ranges for each product are listed on the warranty pages.

## Ceiling Grid—Wall Molding

### Tip 2: Leveling wall molding

It's quicker, easier and more accurate to use a water level or laser than a carpenter's level. Follow the instructions provided with the tool.

### Tip 3: Installing wall molding on drywall

Use appropriate hardware for metal or wood studs. Drilling a small hole in the molding will make using wood screws easier. Avoid over tightening the screw or the wall molding flange can ripple. Attach the molding to the wall every 18 – 24 inches into studs when possible.

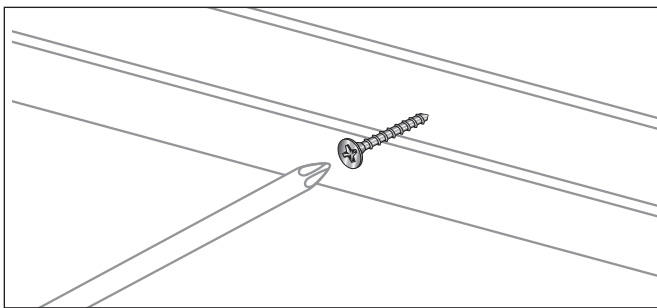

### Tip 4: Installing wall molding on solid or concrete walls

Suspend main beams, as a substitute for wall moldings, next to any wall surfaces that are difficult to penetrate.

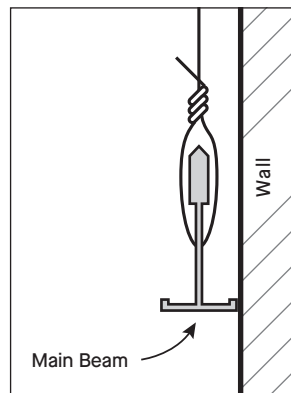

### Tip 5: Installing wall molding along an uneven wall surface

As an alternative to scribing to an uneven wall, create a wood fascia along the uneven wall. The top of the fascia should be attached to the joist, the bottom even with the height of the bottom of the wall molding. When installing the wall molding, make sure the bottom of the molding is even with the bottom of the fascia and secure with screws.

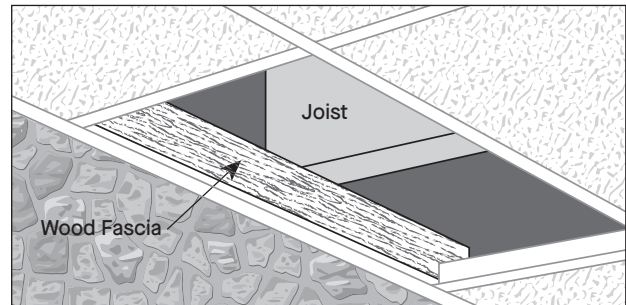

## Ceiling Grid—Main Beams and Cross Tees

### Tip 6: Choosing your hanger wire

We recommend 12 gauge hanger wire for commercial jobs. 12 or 16 gauge can be used for residential installations. For the easiest residential installation, we recommend QuickHang™ grid hooks.

### Tip 7: Bending hanger wires

Bend hanger wires so the bottom of the main beams are level with the bottom of the molding.

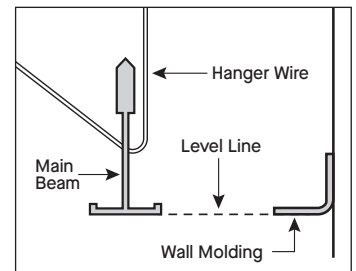

### Tip 8: Supporting the main beam

Twist excess wire tightly around the support stand three times. A tightly wrapped wire will be secure and reduce interference when installing ceiling tiles.

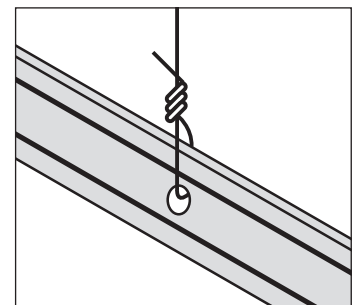

# Tips for Ceiling Installers



## Tip 9: Squaring the grid

It is important that the grid is squared accurately. There's more than one way to do this:

### Method One

1. Stretch a string from one end of the room to the other where the first main beam will hang.
2. Stretch a second string from one side of the room to the other, where the first row of cross tees will be placed. The cross tee notches must line up across each row of mains.
3. Square these strings by stretching the first string. Then use a plumb bob and a 3-4-5 triangle to stretch the second string. Or, you can use a laser to determine the location of these strings.

### Method Two

1. Stretch the first string from one end of the room to the other where the first main beam will hang.
2. Install the first main beam of the first row of mains, cutting the end so a cross tee notch falls at the calculated border panel distance from the end wall.
3. Cut border cross tees to the side wall and clip to the wall molding. Align the main to the string.
4. Install the first section of the second row of mains, cutting the end so a cross tee notch falls at the same calculated border panel distance from the end wall.
5. Place two 4' cross tees between the main beam sections in line with the cut border tees. This will create a 2' x 4' opening in the grid.
6. Measure across the diagonals of this opening. They should be the same. If the measurements differ, trim one of the main beam ends until the measurements are equal.
7. Now this section of grid is square. Stretch the second string through the center of the cross tees where they meet the two mains.
8. Use this string to measure and cut main beams so the cross tee locations in each succeeding row of mains are aligned.

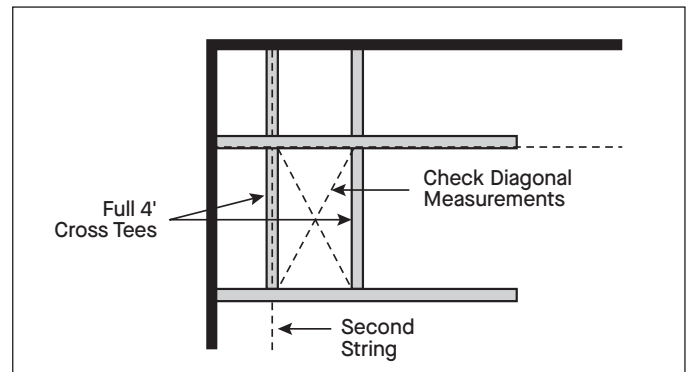

## Easy Up® Track

### Tip 10: Installing Easy Up Track

1. Determine border tile sizes (refer to in-carton ceiling tile or plank instructions)
2. Install the track

The metal tracks should be positioned perpendicular to the joists. The first track should be screwed to the joists 2" from one side wall. Use 2" drywall screws or screws that will penetrate at least 1" into the joists when the track is in its final position. The tracks do not have to end on a joist.

Fasten the tracks end to end in a line until they reach the other end of the room. The tracks do not have to be butted tightly together. You may leave up to 1/4" gap between track ends.

There are two methods for finishing each row of tracks. One method is to cut the track to fit using aviation snips. A second method is to offset the last track section 1/8" to 1/2" from the established line of tracks. Use whichever method is most economical. The second row of tracks should be installed parallel to the first row at a distance of 2" less than the border tile from the side wall.

The third row of tracks should be installed 12" on center from the second row. The remaining rows are installed on 12" centers. The last row of tracks is installed 2" from the other side wall.

Level the tracks as you go along, using a carpenter's level, water level, or laser to establish a level substrate.

**When installing plank ceilings, the first and last rows of tracks are installed 2" from the side walls. The rows of tracks in the center of the room are installed on 12" centers.**

# Tips for Ceiling Installers



## 3. Install the tile (refer to normal instructions)

**If you are scribing the tile** to all walls, you must cut the last row of tile tight to the wall. Hold the tile in place so you can mark where the track falls on the back of the tile. Then insert a clip in the cut edge using the marks to align it. Put the tile in place and push the tile up so the clip snaps onto the track.

## 4. Rooms with offsets and angles

If the room has offsets such as closets, cabinets, or chimney flues, where all angles are close to 90°, remember to run the ceiling tile tracks 1" from the sides of these offsets. Treat them like side walls.

If there are areas where the walls are at an angle other than 90° to the tracks, fasten a furring strip along the wall at these points. The thickness of the furring is the same as the track with a clip on it. Then the tile can be attached to the furring at these points. An alternative is to run short pieces of track 90° to the angle of the wall and use the clips normally.

## Tile Installation Using the Ashlar Method

### Tip 11: Using the Easy Up® System

Calculate the border tile sizes for the room and install the tracks according to the normal instructions. The calculated border size on the wall parallel to the tracks will tell you where to install the second track. Install the remaining rows of track on 12 inch centers from the second row.

Using the Easy Up® System, you have the option to stagger the tile in **either** direction, but not both directions.

Using the calculated size of the border tile in the first row perpendicular to the tracks, stretch a string from one side of the room to the other border measurement from the end wall. (See border note at the end of this tip.) Make sure the string is **below** the finished height of the ceiling tile.

Cut the first tile in the corner of the room to the calculated border width. Now measure from the wall to the string very accurately at two places and cut the first tile to the measured length. Install the tile according to the normal instructions. Measure and cut the second tile in the first row as described in the normal instructions and install it.

To start the next row and stagger the tile, place the third tile temporarily so it is **offset 6"** from the second tile in the first row. (See **Figure 1**) Measure out from the side

wall 12" two places and mark the tile. Cut the tile on the two marks and position it against the side wall and against the first tile in the first row. (See **Figure 2**)

Measure and cut the third tile in the first row

and install it. Place a full tile in the second row as shown and secure with a clip. **If the joints between the tiles are closed when the full tile is lined up, the initial tiles are square. If not, refit the first three tiles and try again.** When these tiles are lined up with the joints closed, finish the first row of tile. Then complete the second row.

When you finish the row of tile, start the next row by offsetting as described above. Continue tile installation as described in the normal instructions including the installation of the last row, offsetting as you go along.

**NOTE: If you wish to offset the tile in the other direction,** lay out the tracks as described above. When you stretch the border guide string perpendicular to the tracks, **stretch an additional guide string 6" closer to the end wall.** (See **Figure 3 and the border note below**) Install the first tile as described in the normal instructions. When you measure for the second tile in the first row, measure from the second string to the wall and cut the tile to that

measurement. This will start the offset in the other direction. Install the tile in the first row alternately using the first string, then the second string to cut the tile.

Continue installing the tile in this manner and finish the room.

**BORDER NOTE:** *If the border tile is less than 9" against the wall where the tile will be offset, add three inches to the calculated border. This will eliminate very small borders when offsetting the tile.*

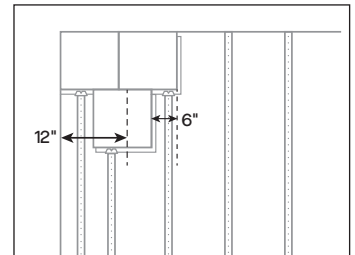

Figure 1

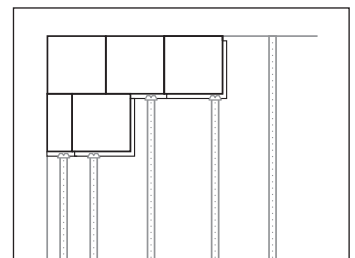

Figure 2

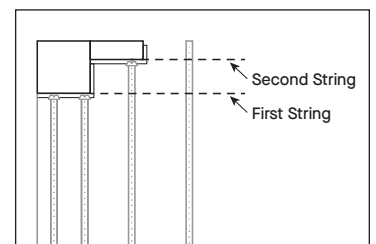

Figure 3

# Tips for Ceiling Installers

## Overhead Support Beams and Ducts

### Tip 12: Boxing around overhead ducts and beams

1. Nail 1" x 2" furring strips (cleats) along both sides of the beam. Construct lattices from 1" x 1-1/2" wood furring strips and 1" x 3" center supports spaced 16" on center. Nail the lattices to the cleats.

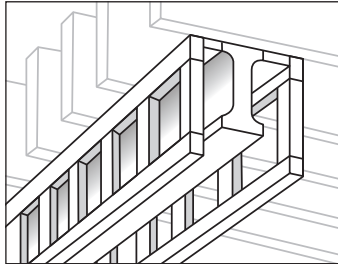

2. Enclose the support beam by nailing or screwing wood paneling or drywall to each lattice along both sides and to the bottom of the lattice frames. To finish the box, attach corner molding.

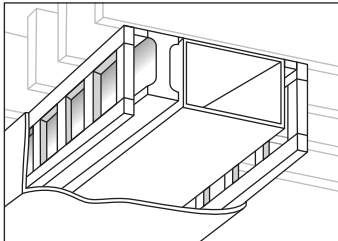

3. If access is needed to the bottom of the boxed-in ductwork, enclose the bottom of the box using grid and panels.

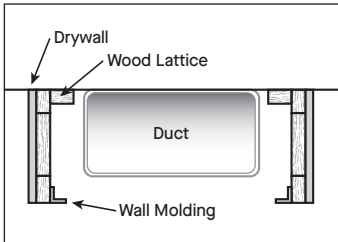

### Tip 13: Using grid to box around obstructions

1. Using aviation snips, make a straight vertical cut on the web of the main beam 1/2" from a cross tee slot. Do not cut through the bottom flange of the main beam; this flange will act as a hinge.

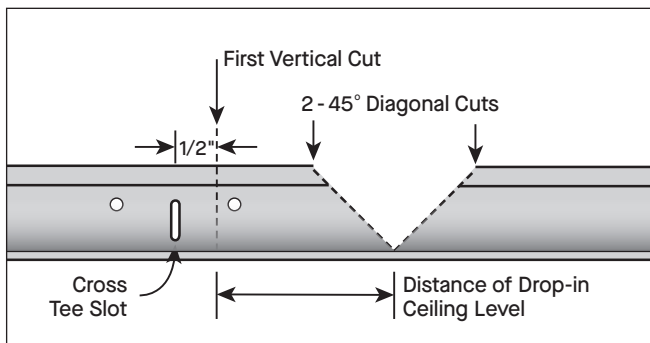

2. From the straight cut on the main beam, measure a distance equal to the required drop in the ceiling level. Here make two 45° angle cuts on the main beam. Once again, do not cut through the bottom flange of the main beam.

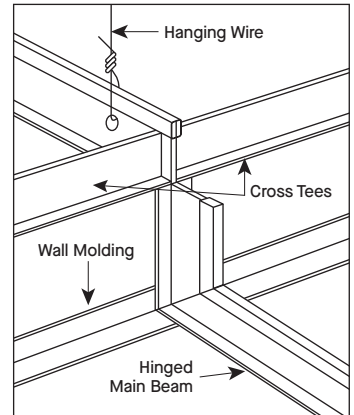

3. Insert cross tees into top slots.
4. Attach grid wall molding to the outside of the bottom bends, using sheet metal screws or pop rivets.
5. Install vertical ceiling panels. Hold the vertical panels in place by drilling or punching a 1/8" hole in the main beam 1/2" above the flange.

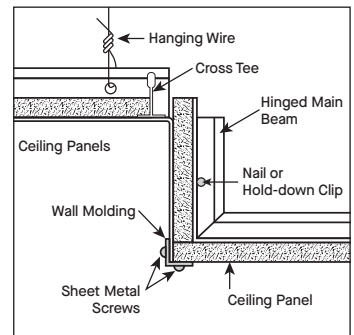

After working the panel into position, use hold-down clips or slide an 8- or 10-penny nail halfway through the hole to hold it in place.

**NOTE:** As an alternative, the dropped section of grid can be fastened to the main ceiling by using wall molding instead of bending the grid.

1. Snap a chalkline across the face of the grid to locate where the molding will be mounted.
2. Attach the molding to the face of the grid using pop rivets or sheet metal screws.
3. Rivet or screw the drop portion of the soffit grid to the molding. The drop grid is bent as indicated previously to form the bottom.
4. Rivet or screw the wall molding to the face of the bottom corner. If the dropped portion comes back up on the other side repeat the process.

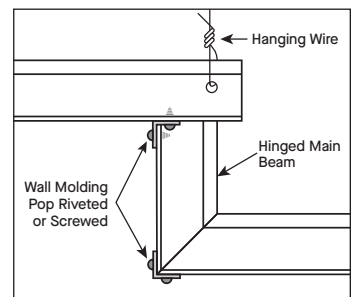

## Support Columns

### Tip 14: Boxing in columns with a suspended ceiling

1. Cut "filler blocks" to fit the outside of the column and the inside of the box at the top and bottom.
2. Cut the filler blocks in half.
3. Place one filler block around the column at the bottom and build the box around it. Let the box extend above the height of the new ceiling.
4. Place the other filler block around the top of the column and inside the box. Nail it in place.
5. Install wall molding around the box at the height of the new ceiling.
6. Miter the corners on the wall molding around the box.

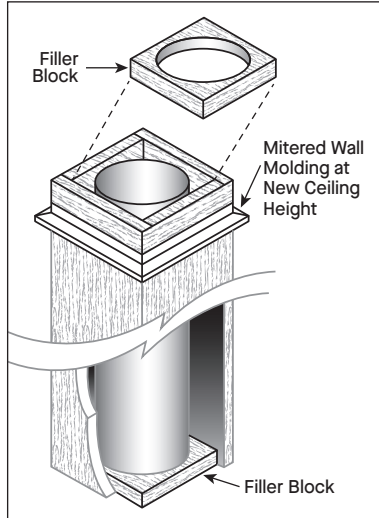

### Tip 15: Installing panels around columns, pipes, vents and posts

1. Measure the exact location of the column in relation to the grid opening.
2. Measure the column size and cut a corresponding hole in the panel. Cut the panel face up through the midpoint of the hole. Make all cuts with a very sharp utility knife.

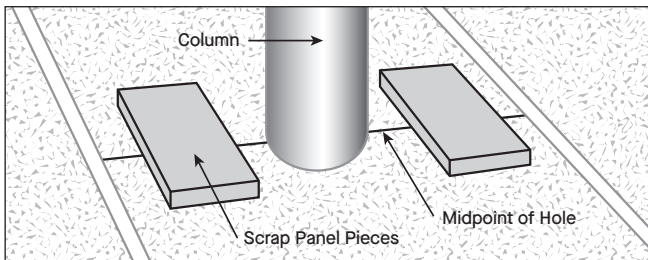

**NOTE:** When cutting #942 and #915, make the cut on the back side of the panel, being careful to cut in the same direction as the facial fissures.

3. Use construction adhesive to attach scrap pieces of panel material to the back of the board to hold it together.

### When fitting fiberglass

1. Measure the exact location of the column in relation to the grid opening.
2. Measure the column size, cut a corresponding hole in the panel and slit once to the nearest edge.
3. Flex the panel into position around the vertical support.

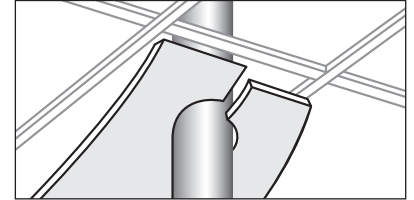

### For fitting panels around ventilation ducts

1. Extend ducts to the new ceiling height.
2. Measure accurately and cut the panel to accommodate the duct size.
3. Install the panel. Then attach the grille to the extension.

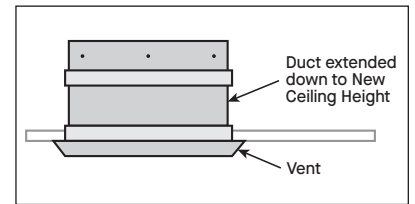

## Windows

### Tip 16: Boxing in basement windows

1. Build a three-sided valance around each window. Use 1/4" plywood for the top. For the three sides, use 1" white pine wide enough to accommodate the ceiling drop and the molding being used. Make certain that the valance is wide enough to allow the window to open and long enough to provide for an open drapery. In most cases, a length of 18" more than the window width is sufficient for the drapery (about 9" on each side of window).

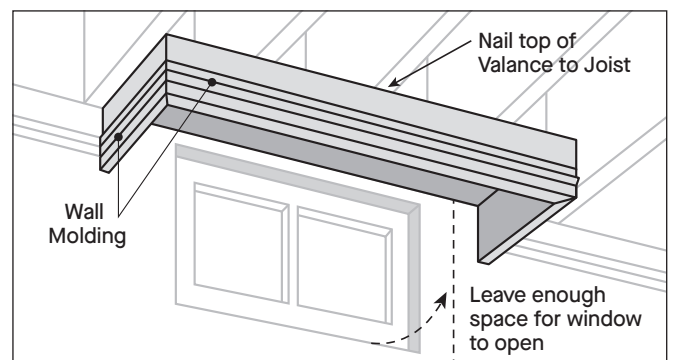

2. Attach the top of the completed valance to the bottom of the ceiling joists.
3. Install the appropriate wall molding at the level desired.

## Tip 17: Installing decorative molding on boxed-in area

If you want to continue using the same decorative molding on the boxed-in areas that you are using on the rest of the room, you should make your box deep enough. For wood molding, allow for the tile and ceiling tile track and clip (1-1/4") or the panel and the depth of the suspended ceiling drop, the height of the molding and the desired reveal at the bottom of the molding.

If you want to use metal wall molding around the box, again you should allow for the tile track and clip or the panel and the depth of the suspended ceiling drop.

Fasten the molding to the box using finish nails or adhesive.

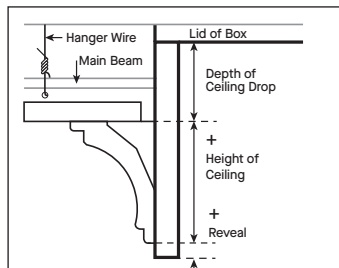
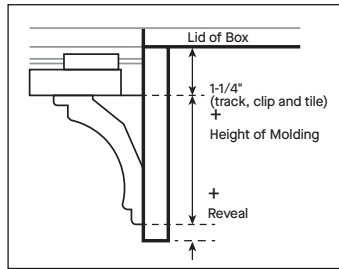

## Cutting reveal edge border panels for crown molding

When using a crown molding at the perimeter of a suspended ceiling with reveal edge panels, you can get "mouse hole" gaps. These holes are created when the tegular panel lays on the molding. To eliminate these holes, cut a normal reveal edge at the panel/molding interface—the same cut made when using angle molding. The reveal edge drops in front of the crown molding, and the grid lays directly on the crown molding, eliminating any gaps.

In most cases, the cut reveal edge will not readily be seen and does not need to be painted. If the cut edge is visible, the tegular edge should be painted to match the face of the panel.

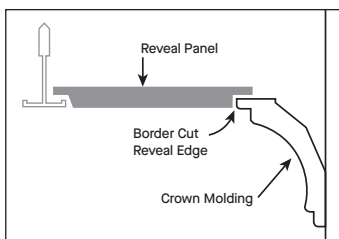

## Ceiling Borders—Panels

### Tip 18: Figuring borders on scored panels or panels with 12" × 12" patterns

To make the job look as good as it can, it is important to make even and equal borders. The key to making the borders look their best is to remember the "look" of the panels. They look like 12" × 12" tile. Therefore, calculate borders like 12" × 12" tile. Here's an example.

If the room measures 16' 6" × 24' 4", the correct borders for 2' × 2' panels would be 15" on two sides and 14" on the other two sides. But with the scoring or pattern on the panels, it would look like a three-inch 12" × 12" border on two sides and a two-inch 12" × 12" border on the other two sides.

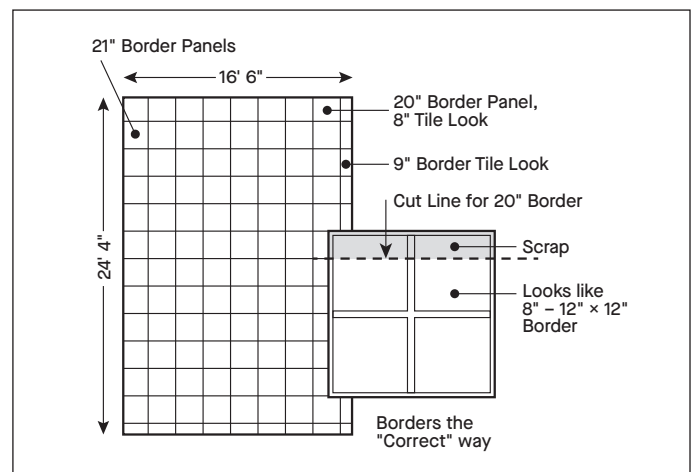
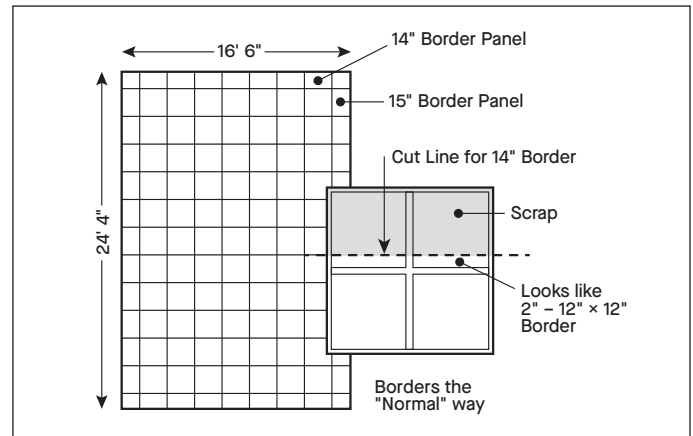

Take the 16' 6" dimension. Calculate the border for 12" × 12" tile. It would be 9". The size of the 2' × 2' border panel would then be the 9" plus 12", or 21". The grid should be laid out using the 21" dimension in one direction.

# Tips for Ceiling Installers

Take the 24' 4" dimension. Calculate the border for 12" x 12" tile. It would be 8". The size of the 2' x 2' border panel would then be the 8" plus 12" or 20". The grid should be laid out using the 20" dimension in the other direction.

Bear in mind that when you lay out the grid this way, the grid may not be centered in the room. The look of 12" x 12" tile, however, will be centered with maximized borders. If the scored or patterned panels are removed later and plain or textured panels are used for replacement, the grid may not be centered, and the borders of the new panels may not be seen.

## Tip 19: Cutting "recessed grid" ceiling border panels

1. Trim reveal edge border panels to the same dimensions as for flat panels. The reveal edge detail must now be cut into the panel.

2. Set the panel into the grid. Draw a light pencil line on the panel using the wall molding as a guide.

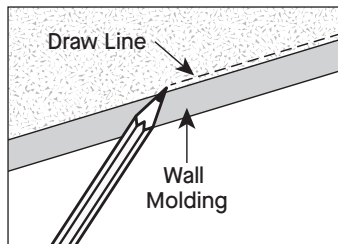

3. Remove the panel. Use a sharp utility knife and straightedge to cut halfway through the panel from the face side along the pencil line.

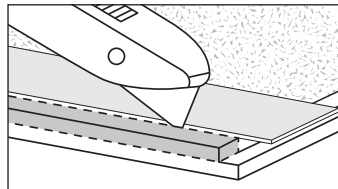

4. Lay the utility knife on its side next to the panel and, with the panel face up, cut in at blade height for a reveal cut.

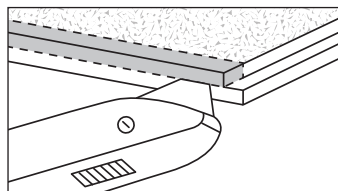

5. Remove the cut strip.

6. Fit the panel into the grid.

## Replacement—Tiles

### Tip 20: Replacing damaged tiles using the Easy Up® Installation System

When performing the steps listed below, use caution to avoid damaging the face edges of tiles adjacent to the tile being replaced.

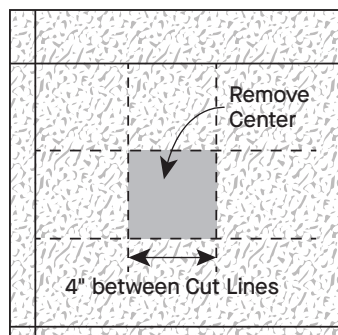

## Removing the damaged tile

1. Make four cut lines in the tile being removed. Always cut from the edge of the tile into the center.

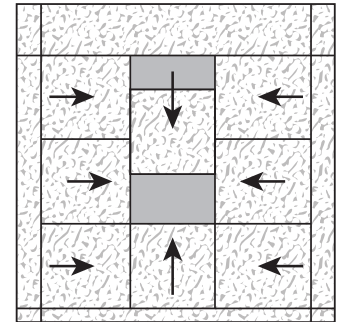

2. After the cuts are made, remove the center section.

3. One at a time, slide the remaining tile sections toward the open center section, and let them drop out.

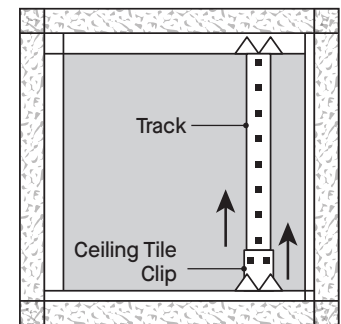

4. Carefully slide the remaining sections of the tile about 1" toward the center opening. This will allow all remaining sections of the damaged tile to drop out.

5. When the damaged tile is removed, you will see the ceiling tile clip which held up the damaged tile.

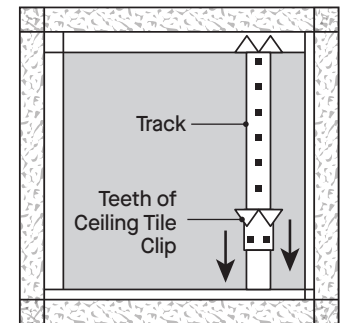

6. Slide the clip into the opening and remove it from the track.

7. Reverse it and snap it back on the track.

8. Slide the clip so that the teeth are just above the tongue of the adjacent tile.

9. Use a screwdriver and a hammer to push the clip into the tile above the tongue.

## Installing the new tile

10. Take a new tile and remove both flanges.

11. Trim flange edges back 1". Insert the knife blade only deep enough to remove the 1/8" thick flange. It must not penetrate the face of the tile.

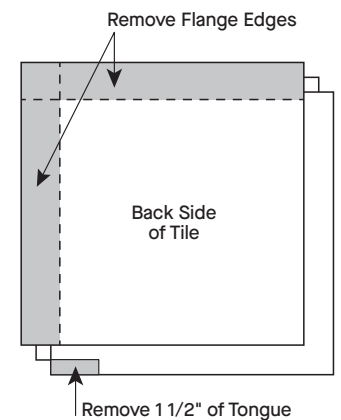



# Tips for Ceiling Installers

12. Remove about 1-1/2" of tongue in one of the corners adjacent to one of the removed flanges.
13. Hold the new tile up in the opening and—on the back of the tile—mark where the sides of the ceiling tile track are.
14. Use these marks as a guide to force a clip into the edge of the tile where the flange was removed.
15. With the tongue sides of the new tile slightly offset to the adjacent tile, insert the partial tongue into the adjacent tile. You will have to push up on the side where the 1-1/2" of tongue was removed to allow the tile to flex slightly.
16. Push the partial tongue of the tile into the groove of the adjacent tile.
17. Push up on the other tongue side and push the tile toward the other tile to insert the full tongue into the adjacent tile.
18. When this replacement tile is lined up with the other tile, push up so the clip snaps onto the track.

## Lighting

### Tip 21: Hanging 2' × 4' lights

When installing 2' × 4' drop-in lights in a suspended ceiling, don't forget to install additional hanger wires in the corners of the light.

Additional wires may be needed for reinforcement of other fixtures mounted in or on the ceiling. For example, some recessed lights may need additional hanger wires when the fixture is heavy and causes the ceiling tile or grid to deflect. Place the additional wires near the support for the fixture or independently support the fixture.

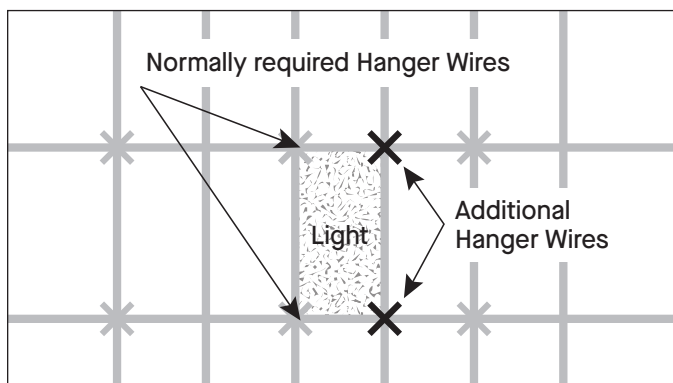

### Tip 22: Installing recessed lighting in a tile ceiling

When installing a recessed light in a tile ceiling, make sure the light is supplied with support bars. These support bars will fit between the joists and hold up the light fixture so it does not rest on the back of the tile. Mount the support bars so the face of the fixture is flush with the face of the tile.

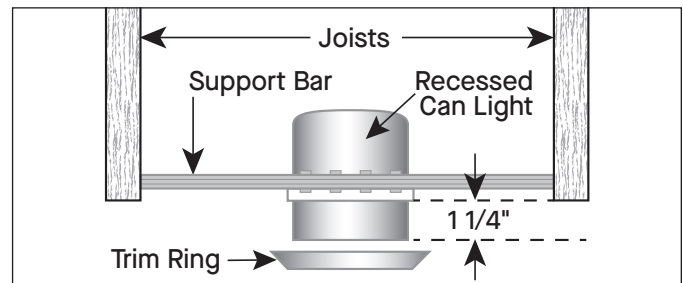

### Tip 23: Installing recessed lighting in a suspended ceiling

**NOTE:** Incandescent lights, even in reflective high hat or can fixtures, are too hot for plastic surfaced panels, such as fiberglass. Follow fixture manufacturer recommendations.

1. Because recessed lights are usually smaller than grid openings, these fixtures should be installed on a subframe. Use extra hanger wires to support the components at the subframe attachment points.

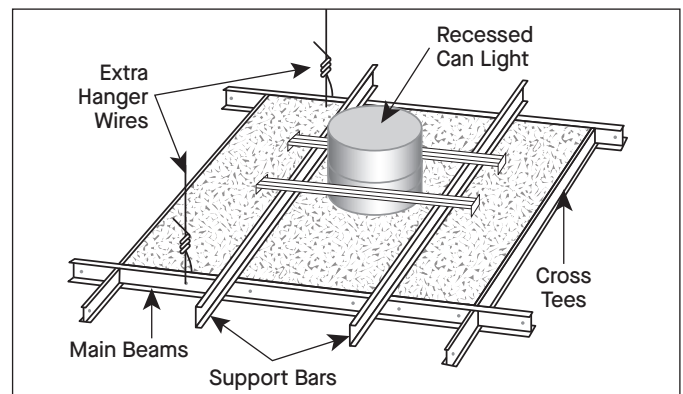

2. Use fixtures with support bars that will rest on the grid. (The alternative is to install an independently hung fixture.)
3. Cut an appropriate fixture opening in the panel.
4. Finish with a trim ring or grille.

# Tips for Ceiling Installers



**NOTE:** No matter what type of lighting fixture is used, all manufacturers' requirements must be met. Both lighting and ceiling components are designed with certain circumstances in mind; these conditions must be compatible. Never use incandescent lights in fire-rated applications.

## Tip 24: Installing surface-mounted lighting in a tile ceiling

When you install a surface-mounted light under a tile ceiling, you must secure the light to the joists or furring strips using screws that will allow at least 1" of the threaded portion of the screw to penetrate the wood. With incandescent lighting, use the correct wattage lamps as indicated by the manufacturer.

If the light is fluorescent, you may have to leave a space between the back of the light and the face of the tile ceiling to allow air to circulate. When fixtures are installed against the face of the tile without the air space, the ballast may overheat and "burn out" more frequently.

## Ceiling Fans

### Tip 25: Mounting a ceiling fan in a tile ceiling

When installing a fan brace where an electric fixture is not already located, the bracket and electrical box should be mounted so that the face of the box is flush with the finished ceiling.

1. If a furring strip or ceiling tile track line up with the electrical box, cut the furring strip or ceiling tile track so it does not interfere with the box opening. Continue the furring or track on the other side of the box.
2. Cut a hole in the tile to fit around the box at least 1/4" larger than the box. Leave some clearance around the box.
3. After the tiles are in place, mount the fan to the box and install the ceiling fan trim ring against the face of the tile.

Use only mounting brackets and electrical boxes recommended for ceiling fan installation. Follow the manufacturers' directions for their installation.

When installing a ceiling fan brace in either a panel or tile ceiling where an electric fixture is already located:

1. Remove the existing ceiling outlet box and bar.
2. Clear the joist space above the ceiling opening of insulation, wiring, etc.

3. Check the location of existing wiring. Remove wiring away from the sides of the joist so it will not be caught behind feet of fan brace.
4. Follow the fan brace manufacturer's instructions for mounting the brace.
5. Reverse the position of the fan brace feet so the feet are up. This will allow the electrical box to extend downward so the face of the box is flush with the finished ceiling. The drop of the ceiling using furring is 1-1/4".

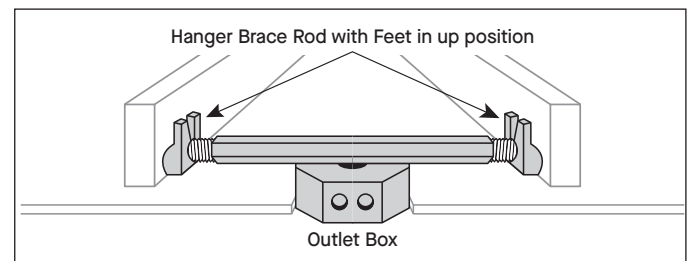

## Vents and Recessed Fans

### Tip 26: Mounting ceiling vents

When you install a power vent in a ceiling to exhaust the air in a bathroom or other area, you must mount the fixture in much the same way as a light fixture or speaker. The fixture must be self-supported. No weight of the fixture may rest on the ceiling tile or panels. Follow fan manufacturer's instructions.

## Cathedral Ceilings

### Tip 27: Installing WoodHaven™ planks on a cathedral ceiling

Always begin the installation at the bottom and work up to the peak. Run the plank horizontally across the plane of the ceiling. Planks should not be run vertically, with the long edge running up the slope of the ceiling, if more than a single plank length is required.

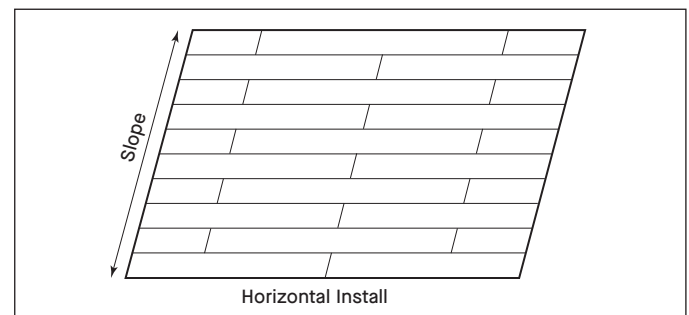

# Tips for Ceiling Installers

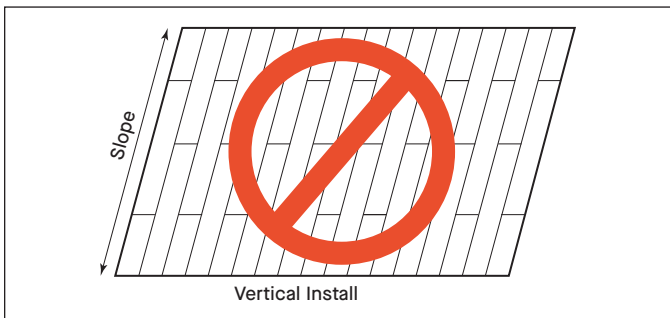

**NOTE:** The Easy Up® Installation System is for ceilings with a slope of less than 10 degrees.

1. The joists will run from the bottom of the ceiling to the top. Fasten a furring strip to the bottom of the joists (rafters) or through the drywall into joists where the ceiling plane meets the bottom wall.
2. Fasten furring strips horizontally every 4' until you get to the top of the peak.
3. Fasten the last furring strip about 2" from the peak.

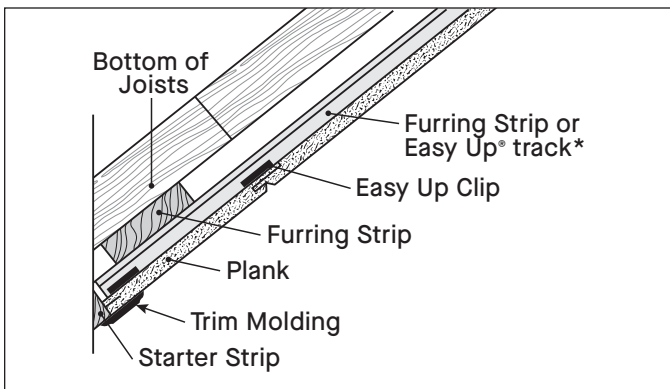

\*Easy Up tracks and clips should be used on ceilings with a slope of less than 10 degrees.

4. If the joists are not even, the furring must be shimmed to flatten it. If the furring strips are not long enough to reach the other end of the room, they must be butted. The butt joints must occur under a joist, and both ends must be double-nailed or screwed to the joist.
5. Once the first layer of furring is installed, start installing a second layer of furring strips running perpendicular to the first layer. For ceilings with a slope of less than 10 degrees, Easy Up® tracks can be used. The tracks will run perpendicular to the first layer of furring. Fasten with drywall screws that allow the thread to fully penetrate the furring.
6. At both ends of the room, install the furring strip or Easy Up tracks 1" from each end wall, running from the bottom of the ceiling plane to within 1" of the peak.

The rest of the rows should be installed parallel to the end tracks on 16"–24" centers.

7. Cut a piece of wood to make a "starter strip" and fasten it to the wall. Cut it at an angle to fit against the wall and have the bottom of the starter strip parallel to the plane of the ceiling. The bottom edge of the starter strip should be flush with the finished face of the ceiling.
8. Measure the straight line distance from the bottom of the ceiling to the top. Figure the width of the border planks so the bottom plank and the top plank are equal. Stretch a string from one end wall to the other to use as a guide string for cutting the width of the first row of plank.
9. Always start the installation from the bottom and go to the top. Let gravity work for you, not against you. If using Easy Up track, it is a good idea to attach some of the Easy Up clips to the track with screws. This will keep the full weight of the ceiling planks from being on the bottom row of planks. When you get to the last row of plank, cut the last row so it ends 1" from the peak.
10. With both sides of the ceiling done, determine the size of the divider at the top. You will not know what size to cut this piece until the plank reaches the top. Its size depends on the angle of the ceiling and the width of the trim molding you use to cover the peak. Do not attempt to have the planks meet each other at the peak without using a divider. The movement of the house will open and close the joint.
11. In this illustration, the divider is fitted to a peak without a ridge pole. Cut the piece to fit the detail in your ceiling. Cover the gap with a trim molding.

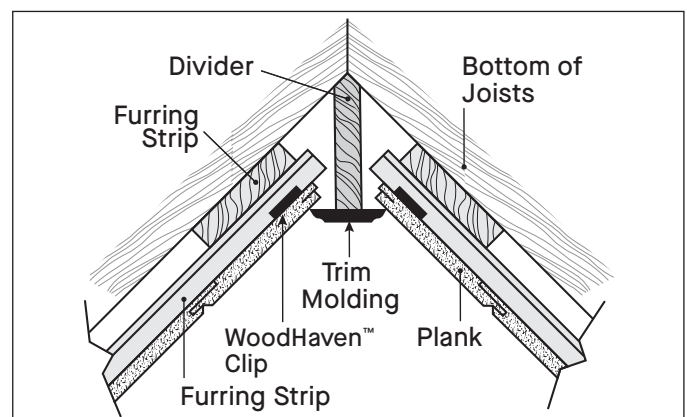

## Tip 28: Installing molding or trim between a suspended panel cathedral ceiling and wall: Two Methods

There are two ways to bridge between a suspended cathedral ceiling and the wall.

### Method One

Bend the wall molding on a sheet-metal bending brake to the correct angle.

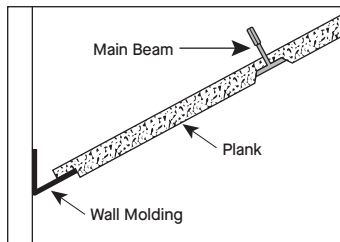

Method 1

### Method Two

Cut a piece of wood trim at the correct angle and fasten molding to wood.

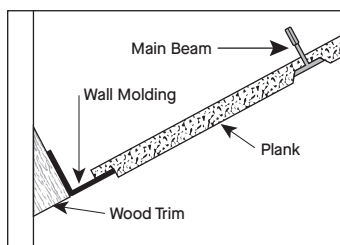

Method 2

## Insulation

### Tip 29: Installing insulation

When an installation calls for insulation on the back of a ceiling, you must be careful how the insulation is applied. With Armstrong® fiberglass panels, you can lay 2' x 4' batts of R-19 insulation that fit on the backs of panels quite nicely.

Do not lay insulation directly on the back of tile or other types of panels. An air space must remain between the back of the panels and the insulation. Create this air space by laying furring strips, wall molding, 12-gauge hanger wire or any number of other rigid supports across the top of the main beams. These rigid members will carry the weight of the insulation and transfer the weight to the mains, leaving an air space between the back of the panels and the insulation.

With tile ceilings, the application of insulation is done less frequently. In most cases, there is no room to apply insulation. If there is room for insulation, make sure that there is an air space between the insulation and the back of the tile. Chicken wire or other wire mesh can be laid over the back of the ceiling, and insulation can be blown in on the wire mesh. The ceiling tracks or furring will then carry the weight of the insulation.

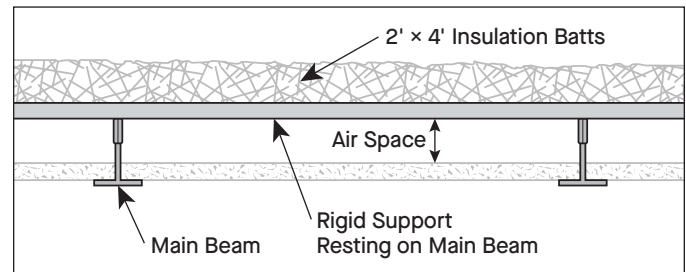

## Miscellaneous

### Tip 30: Installing tile where kitchen cabinet doors are close to the ceiling

When kitchen cabinet doors are less than 1-1/2" from the ceiling, there is not enough clearance to install ceiling tile tracks or wood furring since they would create a drop of 1-1/4". The only installation method which will allow the doors to open is the cement method, using ceiling tile adhesive.

Making sure the existing ceiling is level, follow the directions from the cement manufacturer to prepare the surface and apply and place the cement.

### Tip 31: Removing dirt from tile and panel surfaces

Pencil marks, metal marks, smudges or dirt may be removed from a tile and panel surface with an art gum eraser or chemical sponge.