

SOUNDSCAPES® BLADES™ Linear Acoustical Panels

Ceiling and Walls Installation Instructions – For Wall Installation, see Section 4.6

| SOUNDSCAPES BLADES ACOUSTICAL PANEL ITEMS | | | | | |
|---|---|----------------------|--------------|---------|---------------|
| Item # | Item Name | Included with panels | Sold by the: | Pcs/Ctn | Lbs per panel |
| 7190_ _ | Vertical Panel – Rectangular – 5 x 46 x 2" | – | carton | 4 | 1.6 |
| 7191_ _ | Vertical Panel – Rectangular – 5 x 94 x 2" | – | carton | 4 | 3.3 |
| 3920_ _ | Vertical Panel – Rectangular – 10 x 46 x 2" | – | carton | 4 | 3.2 |
| 3921_ _ | Vertical Panel – Rectangular – 10 x 94 x 2" | – | carton | 4 | 6.5 |
| 7192_ _ | Vertical Panel – Rectangular – 16 x 46 x 2" | – | carton | 4 | 5.1 |
| 7193_ _ | Vertical Panel – Rectangular – 16 x 94 x 2" | – | carton | 4 | 10.4 |
| 3922_ _ | Vertical Panel – Rectangular – 22 x 46 x 2" | – | carton | 4 | 7.0 |
| 3923_ _ | Vertical Panel – Rectangular – 22 x 94 x 2" | – | carton | 4 | 14.4 |
| 7194_ _ | Vertical Panel – Rectangular – 28 x 46 x 2" | – | carton | 4 | 8.9 |
| 7195_ _ | Vertical Panel – Rectangular – 28 x 94 x 2" | – | carton | 4 | 18.3 |
| 7240_ _ | Vertical Panel – 8' Wavelength Concave – 7.5 x 46 x 2" | – | carton | 4 | 2.9 |
| 7241_ _ | Vertical Panel – 8' Wavelength Convex – 10.5 x 46 x 2" | – | carton | 4 | 3.5 |
| 7242_ _ | Vertical Panel – 8' Wavelength Concave – 19.5 x 46 x 2" | – | carton | 4 | 6.7 |
| 7243_ _ | Vertical Panel – 8' Wavelength Convex – 22.5 x 46 x 2" | – | carton | 4 | 7.2 |
| 7244_ _ | Vertical Panel – 8' Wavelength Wave – 10.5 x 94 x 2" | – | carton | 4 | 5.9 |
| 7245_ _ | Vertical Panel – 8' Wavelength Wave – 22.5 x 94 x 2" | – | carton | 4 | 13.7 |
| 7246_ _ | Vertical Panel – 4' Wavelength Wave – 10 x 46 x 2" | – | carton | 4 | 3.2 |
| 7247_ _ | Vertical Panel – 4' Wavelength Wave – 22 x 46 x 2" | – | carton | 4 | 7.0 |
| 7248_ _ | Vertical Panel – 4' Wavelength Wave – 10 x 94 x 2" | – | carton | 4 | 6.5 |
| 7249_ _ | Vertical Panel – 4' Wavelength Wave – 22 x 94 x 2" | – | carton | 4 | 14.4 |
| SOUNDSCAPES BLADES ACOUSTICAL PANELS SUSPENSION AND ACCESSORIES | | | | | |
| For Group Suspension | | | | | |
| 7301 | HD Main Beam | no | carton | 20 | |
| XL7341 | 48" Cross Tee | no | carton | 60 | |
| XL8320 | 24" Cross Tee | no | carton | 60 | |
| 7800 | 7/8" Wall Molding | no | carton | 360 | |
| 6459BL | Rigid Attachment Clip | no | carton | 150 | |
| ARBRKT | Adjustable Hanger Bracket | no | carton | 80 | |
| STAC | Single Tee Adapter Clip | no | carton | 120 | |
| For Group Suspension – 360° Painted Grid | | | | | |
| 56418 | 144" HD Main Beam – 360° Painted Grid | no | carton | 240 | |
| 56421 | 48" Cross Tee – 360° Painted Grid | no | carton | 240 | |
| 56419 | 24" Cross Tee – 360° Painted Grid | no | carton | 120 | |
| 7800 | 7/8" Wall Molding | no | carton | 360 | |
| For Individual Suspension | | | | | |
| 6655 | 4-Point Hanging Kit (4 Suspension Points) | no | bag | 1 kit | |
| AXM34STR3XX | Axiom Molding 360 (for Direct Attach) | no | piece | 1 | |

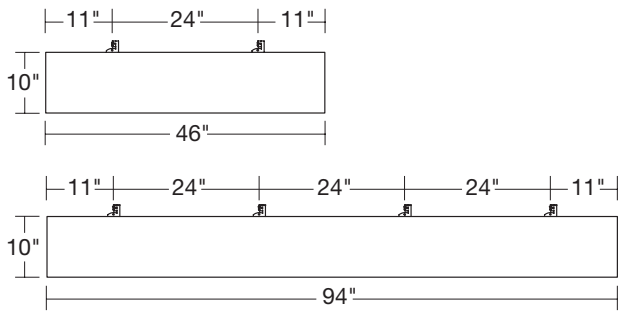

NOTE: All 4' and 8' panels have the same hardware (clip) spacing. To see drawings of all SoundScapes® Blades™ panels, see data page.

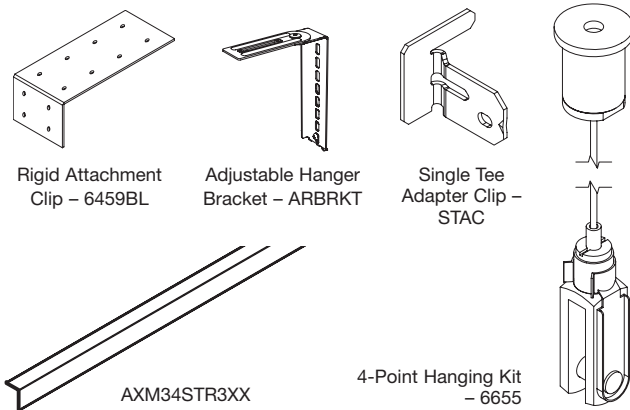

DO NOT REMOVE SOUNDSCAPES® BLADES™ PANELS FROM THE CARTON UNTIL YOU HAVE READ THESE INSTRUCTIONS IN THEIR ENTIRETY.

1.0 GENERAL

1.1 Product Description

SoundScapes Blades panels are vertical, acoustical fiberglass panels designed to be suspended from a Prelude® XL® heavy-duty suspension system in groups, independently from cables/wires, or independently directly attached to a ceiling or wall structure.

Additionally, SoundScapes Blades 5" panels (items 7190 and 7191) can be installed on walls. See Section 4.6 for more details.

SoundScapes Blades panels are engineered for use in seismic areas only when indicated components are used and installed in accordance with these installation instructions.

SoundScapes Blades panels are made from fiberglass and finished on all edges and surfaces (except for the top edge) with a DuraBrite® acoustically transparent membrane.

SoundScapes Blades panels are available in 20 different shapes and sizes, including rectangular panels as well as wavelength panels that have curved edges. See data page for dimensions of each panel. Additionally, custom shape panels can be ordered through the Architectural Specialties group.

There are 14 standard color options for the finished Blades™ panels. Premium and custom finishes can also be manufactured. Contact TechLine customer support, Architectural Specialties, or an Armstrong representative for additional information. Field painting will void the product warranty.

For minor surface and edge scratches on white Blades panels, use Armstrong® SuperCoat™ touch-up paint, item #5761. This paint provides an excellent one-coat edge treatment that will match the original vertical panel. For minor surface and edge scuffing or scratches on colored Blades panels, use matching Sherwin-Williams® paint that can be ordered through the Armstrong Sample Center or purchased from your local Sherwin-Williams store. For standard colorations panels, touch-up paint is available for purchase at Sherwin-Williams using the following reference:

| PAINT TYPE: SHERWIN-WILLIAMS PRO MAR 200 ZERO VOC – FLAT | | | |
|--|----------------------|--------------------------|-----------------------------|
| Armstrong Color SKU | Armstrong Color Name | Sherwin-Williams Color # | Sherwin-Williams Color Name |
| 2824SH | Shell | SW7537 | Irish Crème |
| 2824LM | Pale Lemon | SW7561 | Lemon Meringue |
| 2824PC | Pecan | SW7518 | Beach House |
| 2824SK | Sky | SW7613 | Aqua Sphere |
| 2824MS | Moss | SW7727 | Koi Pond |
| 2824SE | Stone | SW7642 | Pavestone |
| 2824RE | Reef | SW6945 | Belize |
| 2824LA | Lagoon | SW6955 | Impromptu |
| 2824PM | Plum | SW6286 | Natural Grape |
| 2824CN | Cranberry | SW6594 | Poinsettia |
| 2824KW | Kiwi | SW6712 | Luan Green |
| 2824TG | Tangerine | SW6886 | Invigorate |
| 2824BK | Black | SW6990 | Caviar |

1.2 Storage and Handling

SoundScapes Blades panels shall be stored in a dry interior location and shall remain in their original cartons prior to installation to avoid damage. The cartons shall be stored in a flat, horizontal position. The vertical panels should not be removed from the carton until the suspension system is installed. Proper care should be taken when handling Blades panels to avoid damage and soiling. White cotton or latex gloves are recommended for handling. It is recommended that two installers handle 94" Blades panels.

NOTE: Blades panels in colors other than white are paper wrapped. To avoid fingerprints, do not remove paper wrapping until installation is complete.

1.3 Site Conditions

SoundScapes Blades panels can be installed where the temperature is between 40°F (4°C) and 120°F (49°C). Panels cannot be used in exterior applications, where standing water is present, or where moisture will come in direct contact with the Blades panel.

1.4 SoundScapes Blades Panel Layout

SoundScapes Blades acoustic panels are available in a variety of lengths and shapes and are able to be attached to a Prelude® suspension system in groups or individually suspended using the 6655 hanging kit or Axiom® molding, as described in Section 4. Please note that panels require a minimum of 2" gap between ends of panels for best visual due to potential bowing up to 1/8".

1.5 Fire Performance

SoundScapes Blades panels may obstruct or skew the existing or planned fire sprinkler water distribution pattern or possibly delay the activation of the fire sprinkler or fire detection system. Designers and installers are advised to consult a fire protection engineer, NFPA 13, and their local codes for guidance on the proper installation techniques where fire detection or suppression systems are present.

1.6 Safety Considerations – Working with Fiberglass and Mineral Fiber Products

General Construction Site Safety Information: Precautions should be taken to ensure that handling and installation procedures are taken to minimize dust generation. It is recommended that the work site is well ventilated. If high dust levels are anticipated during installation, use an appropriate NIOSH designated dust respirator. Safety glasses and gloves are recommended during installation.

First Aid Measures: If contact occurs, flush eyes and/or skin with water for at least 15 minutes and remove contaminated clothing. Wash work clothes with warm water and mild soap. Refer to Armstrong World Industries SDS (which includes information on established occupational exposure limits), available at armstrongceilings.com/commercial.

1.7 Warranty

The SoundScapes® Blades™ system has been tested based on the installation method described in this document. Warranty will be voided if you do not follow instructions and guidelines.

1.8 HVAC Design and Operation and Temperature/ Humidity Control

Proper design for both air supply and return air, maintenance of the HVAC filters, and building interior space are essential to minimize soiling. Before starting the HVAC system, make sure the supply air is properly filtered and the building interior is free of construction dust. SoundScapes Blades are for interior use only and cannot be used where standing water is present or where moisture will come in direct contact with the ceiling.

1.9 Plenum

SoundScapes Blades panels allow downward accessibility to the plenum. Blades™ panels can be unattached and re-attached to grid or cable hanging kits.

Blades panels are installed below the suspension system, and do not need to travel above the suspension system during installation.

Installations with grid require a minimum of 3" of space in the plenum to install the hanger wires for the suspension system.

NOTE: Light fixtures and air handling systems require more space and will determine the minimum plenum height for the installation.

1.10 Cleaning

Dust and loose dirt may easily be removed by brushing or with a vacuum cleaner. Vacuum cleaner brush attachments such as those designed for cleaning upholstery or walls do the best job. Be certain to clean in one direction only. This will prevent rubbing dust into the surface of the ceiling. Use a clean, dry, soft, white cloth to wipe off any dirt or greasy fingerprints. If this does not clean the panel, use a damp, clean, soft, white cloth or sponge with a mild detergent to wipe the panel. Remove any remaining moisture with a dry cloth.

For minor surface and edge scratches on white Blades panels, use Armstrong® SuperCoat™ Touch-up Paint item #5761. This paint provides an excellent one-coat edge treatment that will match the original vertical panel.

For minor surface and edge scuffing, or scratches on colored Blades panels, use matching Sherwin-Williams® paint that can be ordered through the Armstrong Sample Center, or purchased from your local Sherwin-Williams store.

2.0 DESIGN CONSIDERATIONS

2.1 Directionality

Ceilings

The surface of SoundScapes Blades is a non-directional, slightly textured surface. Overall installation designs are non-directional with differences based on installation method. Blades panels installed using Prelude® suspension system will be limited to panels running parallel or 90 degrees to the main beams.

However, SoundScapes Blades panels installed with the item 6655 hanging kit or with Axiom® molding can be installed in any direction, allowing for complete freedom in designs. See installation Section 4 for further details.

Walls

For guidelines and instructions on wall installations, see Section 4.6.

2.2 Sprinklers

SoundScapes Blades panels may obstruct or skew the existing or planned fire sprinkler water distribution pattern, or possibly delay the activation of the fire sprinkler or fire detection system. Designers and installers are advised to consult a fire protection engineer, NFPA 13, and their local codes for guidance on the proper installation techniques where fire detection or suppression systems are present.

The minimum drop of the SoundScapes Blades panels will be a 6" drop from the plenum when using the 5" panel with the direct-attach method (AXM34STR3XX). Alternate product sizes and installation methods can have greatly varying drops.

2.3 Plenum

SoundScapes Blades panels allow downward accessibility to the plenum. Blades panels can be unattached and re-attached to grid or cable hanging kits.

Blades panels are installed below the suspension system, and do not need to travel above the suspension system during installation.

Installations with grid require a minimum of 3" of space in the plenum to install the hanger wires for the suspension system.

NOTE: Light fixtures and air handling systems require more space and will determine the minimum plenum height for the installation.

2.4 Approximate System Weight and Attachment to Deck/Wall

Overall system weight will be based on the weight of the Blades panels and installation method.

SoundScapes Blades panels have an approximate weight of 1.0 lbs/SF. Based on your layout and the panels used, you will need to calculate lbs/SF for the installation method. See table on page 1 for weight per panel.

Ceiling Hanger Connections: Hanger connections to the ceiling structure must follow the fastener manufacturer's instructions and referenced code based on system weight and structure into which the suspension system will be fastened. Average system weight per square foot will depend on the design layout and must be calculated by installer.

Wall Connections: For guidelines and instructions on wall installations, see Section 4.6.

Correct mechanical fasteners must be used to install Axiom® molding and SoundScapes® Blades™ panels directly to a wall. It is advised that connections be screwed directly to wall studs. When this is not possible, contractor must select appropriate anchors for the wall substrate as well as the weight of the system.

2.5 Accessibility

SoundScapes Blades systems are vertically mounted panels. While installed, accessibility will be limited to reaching through panels to suspension system or plenum/ceiling deck. Alternatively, Blades™ panels can be removed. Blades panels installed in grid rout holes can be lifted up and pulled free. Blades panels installed with screws can be unscrewed and replaced, as necessary. See installation Section 7 for further details on panel attachments to grid.

2.6 Cutting Blades Panels

SoundScapes Blades panels cannot be field cut. Contact Architectural Specialties for custom length Blades panels.

2.7 Blades Panel Layout

Minimum spacing between Blades panels depends on the installation method.

- Independent Suspension with Hanging Kits – 12" O.C.
- Attached to Grid – 6" O.C.
- Directly Attached to Axiom Molding – 6" O.C.

3.0 ACCESSORIES

The installation hardware for SoundScapes Blades panels is already included in the panel and can be used with multiple suspension options.

Four-point Hanging Kit (item 6655)

SoundScapes Blades panels can be independently suspended using aircraft cables and quick release, fork gripper adjusters. The item 6655 hanging kit includes: (4) 96" long cables with stops, (4) fork gripper adjusters, and (4) top end connectors. See installation Section 4.2 for further details.

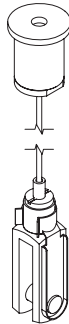

Axiom® Molding (item AXM34STR3XX) for Direct Attach to Walls or Ceilings

SoundScapes Blades panels can be independently installed direct to a ceiling or wall surface using Axiom molding. Molding will be mostly hidden behind the Blades vertical panel, and will assist with alignment of the installation. The 360 degree painted finish ensures that the molding will be less visible upon final installation. Molding is 120" and is sold by the piece. See installation Sections 4.5 and 4.6 for further details.

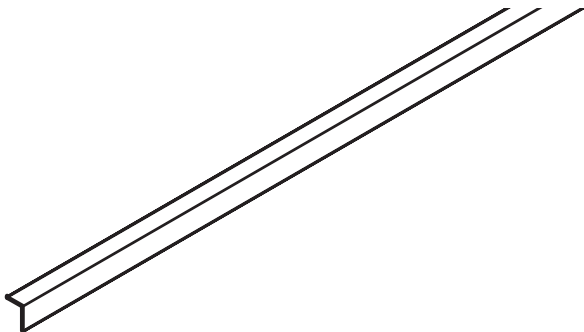

AXM34STR3XX

4.0 SUSPENSION SYSTEM

The requirements listed here represent the manufacturer's minimum acceptable installation recommendations, and may be subject to additional requirements established by the local authority having jurisdiction.

- All installations should follow ASTM C636.
- All references to suspension component duty ratings are per ASTM C636.
- The suspension system chosen must be fastened to the structure per code in your area.

4.1 Suspension Options

There are four different types of suspension options for use with SoundScapes Blades panels. These methods are:

- Independently suspended from structure with the item 6655 4-point hanging kit
- On a heavy-duty Prelude® XL® 15/16" suspension system in a standard 2' x 2' layout
- On a heavy-duty Prelude XL 15/16" suspension system in a "Rail" layout attached to deck by Rigid Attachment Clip (item # 6459BL) or Adjustable Hanger Bracket (ARBRKT)
- Attached to Axiom molding which is directly attached to structure in order to minimize the distance from the ceiling deck to the Blades. This attachment method can also be used for wall installations. See Sections 4.5 and 4.6 for further details on this installation method.

Each vertical panel has embedded attachment clips along the top of each panel.

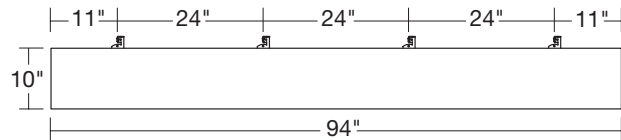
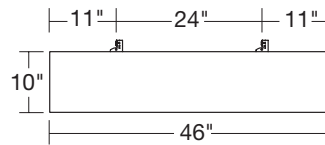

NOTE: All 4' and 8' panels share hardware spacing.

4.2 Independent Suspension with Hanging Kit

SoundScapes Blades panels can be independently suspended using aircraft cables and quick release fork gripper adjusters. The item 6655 hanging kit includes: (4) 96" long cables with stops, (4) fork gripper adjusters, and (4) gripper structure anchors.

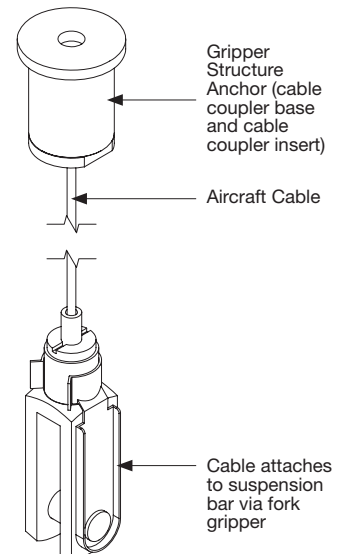

NOTE: For layout considerations in a seismic installation, refer to Section 9.0.

- Determine the location to hang the Blades™ panels
- Fasten the appropriate anchor to the structure that will interface with the gripper structure anchors
- Remove the unneeded portion of the clip with tin snips

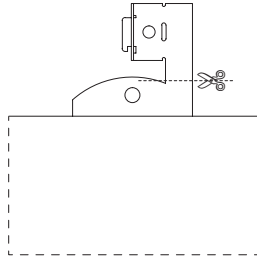

1. Attach the fork gripper and pin through the hole in the embedded attachment clip within the Blades panel.

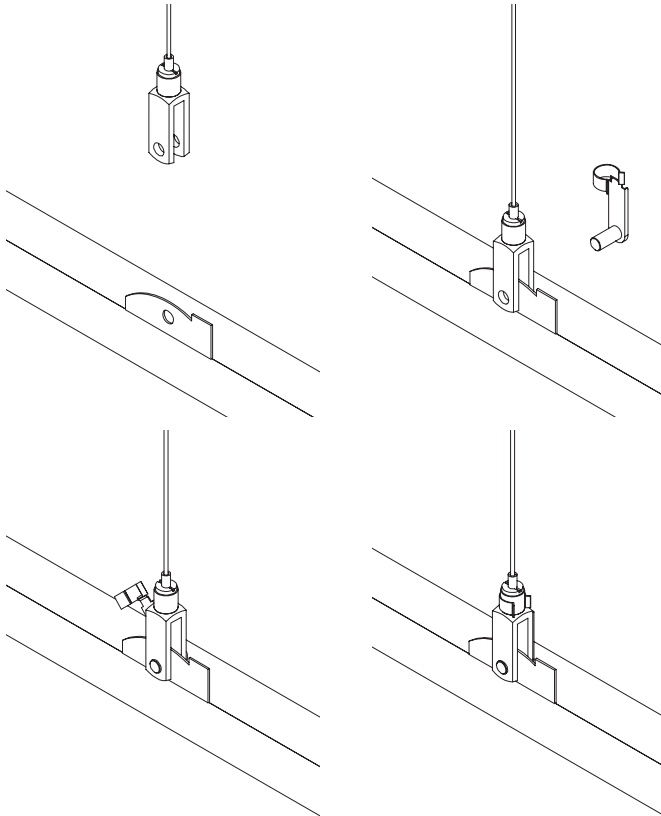

2. Thread the aircraft cable through the fork gripper with cable extending beyond the gripper by at least 1".
3. Level the Blades panel to the finished height, carefully ensuring that the cable does not scratch or puncture the Blades panel, and trim the aircraft cable at the desired length once finished.
4. To release the cable and lower the Blades panel, take all weight off the fork gripper, push the release mechanism, and simply slide the cable out as needed.

IMPORTANT SAFETY AND QUALITY NOTE: Do not allow any portion of wire or aircraft cable to drop below the top of a panel while adjusting final height. Doing so could cause damage to the edge of the panel.

4.3 Group Installation on a Standard 2' x 2' Layout of Heavy-Duty Prelude® XL® 15/16" Grid

SoundsScapes® Blades™ panels can be installed on Prelude XL heavy-duty suspension system by using the embedded attachment clips on the top of the SoundScapes Blades panels that rest on the flange of the grid.

- The suspension system must use Prelude XL heavy-duty main beams (includes 360° Painted Grid) and full-height cross tees (1-11/16"). These suspension components are necessary despite the seismic design category of the installation.
- For Seismic Design Category C, D, E, and F installations refer to Section 9 Seismic Installations and the Armstrong® Seismic Rx® guide to modify the suspension system to meet IBC requirements. For seismic category A and B installations refer to the following guidelines:
- Main beams closest to the perimeter must be no farther than 24" from each wall
- Main beams must have a hanger wire within 24" of the walls, and then a maximum of 4' O.C.
- The field of the suspension system assembly must be a standard 24" x 24" module build (main beams 48" O.C., 48" cross tees perpendicular to the main beams at 24" O.C., and 24" cross tees spanning the midpoints of the 48" cross tees. Once the suspension system is in place refer to Section 4.0 Blades Panel Attachment to Suspension System.

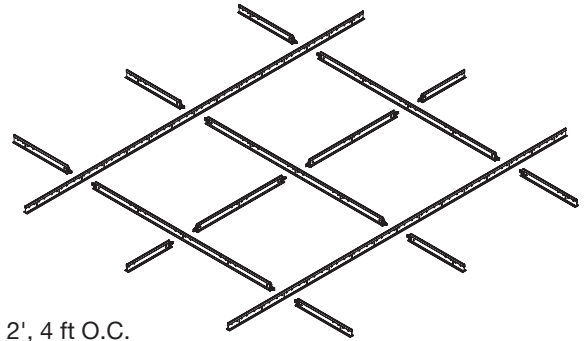

4.4 Group Installation on a "Rail" Layout of Heavy-Duty Prelude XL 15/16" Grid

SoundsScapes Blades panels can be installed on a grid "Rail" system, using the following components:

- Prelude XL heavy-duty main beams (includes 360° painted grid main beams)
- Main beams must be spaced at 24" O.C.
- The rigid attachment clip (Item 6459BL) or ARBRKT brackets to attach main beams to the deck
- 2' cross tees installed at 4' or 6' O.C. for alignment and squaring

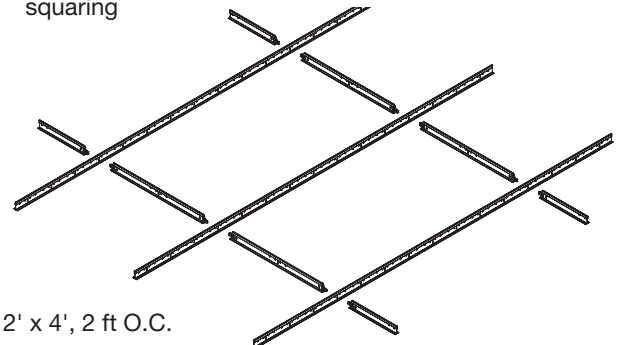

4.4.1 Brackets

Brackets are used to attach the main beams to structure. Brackets are recommended within 12" of the ends and not more than 48" on center along the run of main beams. Brackets allow suspension system elevation adjustment from 1-3/4" to 5-1/2". Avoid installing the bracket on the main beam at the location of cross tees.

6459BL Rigid Attachment Clip – This clip must be accurately located before fastening to the structure for correct suspension system alignment and proper panel fit. Use a string line or laser to establish a straight row for bracket attachment. Use the appropriate fastener to anchor the clip to the structure.

ARBRKT Adjustable Hanger Bracket – This bracket is adjustable after fastening to the structure with a screw. This allows flexibility and minor variations for attachment to the structure. Use of a string line or laser is still recommended for this bracket. The suspension system can easily be aligned and squared for proper panel fit. Use the appropriate fastener to anchor the clip to the structure.

4.4.2 Main Beams

Main beams will run perpendicular to the Blades panel length and will act as carrying rails. Blades panel attachment will only be to main beams, and cross tees are added only for alignment and squaring of the system.

- 7301 Prelude® XL® main beams are installed at 24" on center to align with the embedded attachment clips
- The main beams must be attached to the brackets so that cross tee rout holes are located for proper spacing of the Blades panels per the reflected ceiling plan

First Row of Main Beams:

Use clamps or vise grips to temporarily secure the first main beam to the brackets. Adjust for proper location and elevation. Use two sheet metal screws (Type #8 x 1/2" sharp point screw) to fasten the bracket to the main beam. Use the typical method to join sections of main beams for long runs.

Additional Rows of Main Beams:

Brackets should be installed accurately to accommodate 24" O.C. main beam spacing. Use clamps or vise grips to temporarily secure the main beam in the second row to the brackets. To aid in alignment and squaring of the system, use 2' cross tees. These cross tees can be installed 48" or 72" O.C., in order to avoid rout holes that are needed for attachment of the Blades panels per the RCP.

Check System Squareness:

System squareness is a critical stage of suspension system installation. System squareness must be within 1/16" for the measurement of a 24" x 48" module. The system must be square or this will result in improper panel fit, poor alignment, and an unacceptable visual. To measure diagonals use a carpenter's square, or run a laser or dry line perpendicular to the mains to align rout holes. Secure the second main beam to the brackets with sheet metal screws.

For installations with multiple rows of main beams:

Once the first two main beams are square, temporarily clamp the furthest main beam of the installation. Clamp a dry line to a reference rout hole in the furthest main beam and then pull tight and clamp to the matching rout hole in the first main beam. Adjust the furthest main beam so that the dry line intersects the rout holes of the first two squared main beams.

Screw attach the furthest main beam. Next, install all remaining main beams within the field of the installation so that the rout holes intersect the dry line. This will ensure proper alignment throughout the installation.

Trim off any excess main beam ends to keep the main beam concealed.

4.4.3 Cross Tees

Continue to install the remaining 24" cross tees at 48" O.C. throughout the rest of the installation. Since the main beams are secured with rigid brackets, you may need to roll the top bulb away to ease insertion of the cross tee clip. All single tee connections at the perimeters will need to be reinforced with an STAC clip for both seismic and non-seismic installations.

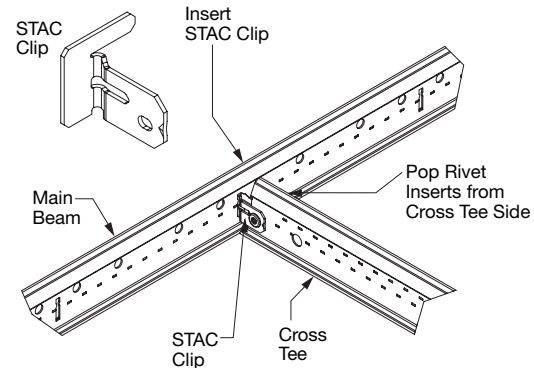

4.5 Direct Attach with Axiom® Molding for Ceilings

See *Pictorial Installation Instructions in the Appendix*

SoundScapes® Blades™ panels can be directly attached to Axiom molding that is fastened to a ceiling structure using the following components:

- Axiom molding (AXM34STRXX)
- Fasteners for Blades panels to Axiom molding attachment (#8 x 7/16" self-drilling wafer head screws, provided by contractor)
- Appropriate fastener for Axiom molding to structure connection (specified and provided by contractor) based on the weight of the panels (11lb/SF) and the ceiling substrate.

4.5.1 Axiom Molding to Ceiling Structure

Axiom molding (AXM34STRXX) comes in 10' lengths and can butt end to end for long runs of Blades panels. When terminating a row, the molding can be cut to match the length of the panel it is suspending. The molding can be cut with tin snips or a circular saw.

Each piece of Axiom® molding must be attached to structure at 16 - 24" O.C. and within 12" of the ends. The attachment must be made with the appropriate fastener based on the material the molding is being attached to (i.e. steel framing, concrete, etc.) and the weight it must hold. The molding should be pre-drilled to facilitate the fastener connection.

The Axiom molding must be installed flush to the ceiling and can be installed on up to a 30-degree slope, with the molding and panels running up the slope.

See *Appendix for detail drawings of Direct Attach Installation.*

4.5.2 Blades™ Panels Attachment to Axiom® Molding (Ceiling)

For direct attachment to the Axiom molding the top portion of the embedded attachment clip must be cut off with tin snips.

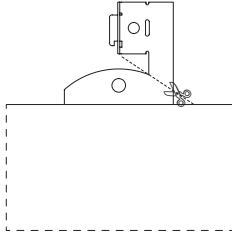

- The embedded attachment clip should be placed on the inside edge of the molding with the back (unfinished) edge of the blade pressed up against the molding.

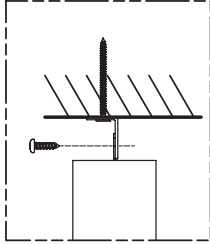

- Screws must go through the pilot hole in the embedded attachment clip first, and then into the Axiom molding.
- Blades panels are screw-attached to the Axiom molding with #8 x 7/16" self-drilling wafer head screws (provided by contractor).
- Screw attachments must be made at each embedded hardware location along the panel (two per 46" panel, and four per 94" panel).
- Screw tips may be visible based on spacing of Blades panels and viewing angle. Flexible 1/8" - 3/16" screw thread protectors can be used to cover screw points coming through the Axiom molding. These are optional and provided by the contractor.
- Screw heads for the Axiom molding to wall attachment and Blades panels to Axiom molding may be visible based on panel spacing and viewing angle. Touch up paint (provided by contractor) to match the Axiom molding and embedded hardware can be used in these scenarios.
- Blades panels should not be installed with less than 2" between ends.
- Minimum spacing between rows of Blades panels is 6" O.C.
- Spacing between rows and depth of the Blades panels may require a progressive installation.

4.6 Direct Attach with Axiom Molding for Walls (5" Blades panels only)

See Pictorial Installation Instructions for Direct Attach in the Appendix

SoundScapes® Blades™ 5" panels (7190 and 7191) can be directly attached to Axiom molding that is fastened to a wall structure using the following components:

- Axiom molding (AXM34STR3XX)
- Fasteners for Blades panels to Axiom molding attachment (#8 x 7/16" self-drilling wafer head screws, provided by contractor)
- Appropriate fastener for Axiom molding to structure connection (specified and provided by contractor) based on the weight of the panels (1lb/SF) and the wall substrate.

4.6.1 Axiom Molding to Wall Structure

Axiom molding (AXM34STR3XX) comes in 10' lengths and can butt end-to-end for long runs of Blades panels. When terminating a row, the molding can be cut to match the length of the blade panel it is suspending. The molding can be cut with tin snips or a circular saw.

Each piece of Axiom molding must be attached to structure at 16 - 24" O.C. and within 12" of the ends. The attachment must be made with the appropriate fastener based on the material the molding is being attached to (i.e. steel framing, concrete, etc.) and the weight it must hold. Item 7190 - 46" Blades panels weigh approximately 1.52lbs each, and item 7191 - 94" Blades panels weigh approximately 3.25lbs each. The molding should be pre-drilled to facilitate the fastener connection.

The Axiom molding must be installed flush to the wall and can be installed at angles up to 30 degrees off of vertical. All wall installations should be installed at least 6' above finished floor or higher to avoid damage.

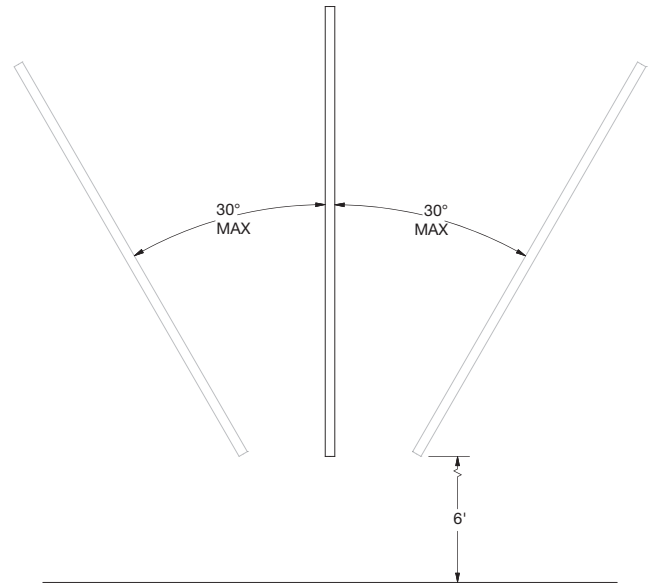

Blades panels should never be installed horizontally to the floor or used as a support for other weight.

4.6.2 Blades Panels Attachment to Axiom Molding (Wall)

For direct attachment to the Axiom molding the top portion of the embedded attachment clip must be cut off with tin snips.

Please note: Cut the panel hardware on an angle to mirror the shape of the rounded portion of the hardware for best clean-cut results. Installer should ensure that sharp edges are not accessible to building occupants.

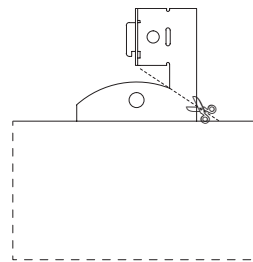

Blade panel with hardware attached to Axiom molding

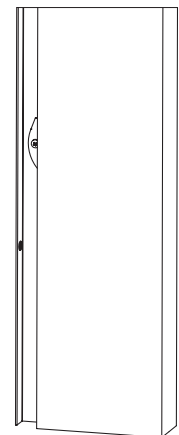

- The embedded attachment clip should be placed on the inside edge of the molding (see section detail) with the back (unfinished) edge of the blade panel pressed up against the molding.
- Screws must go through the pilot hole in the embedded attachment clip first, and then into the Axiom® molding.
- Blades™ panels are screw attached to the Axiom molding with #8 x 7/16" self-drilling wafer head screws (provided by contractor).
- Screw attachments must be made at each embedded hardware location along the Blades panel (two per 46" panel, and four per 94" panel).
- Screw tips may be visible based on spacing of Blades panels and viewing angle. Flexible 1/8" - 3/16" Screw thread protectors can be used to cover screw points coming through the Axiom molding. These are optional and provided by the contractor. Installer is responsible to ensure that sharp points are not accessible to building occupants.

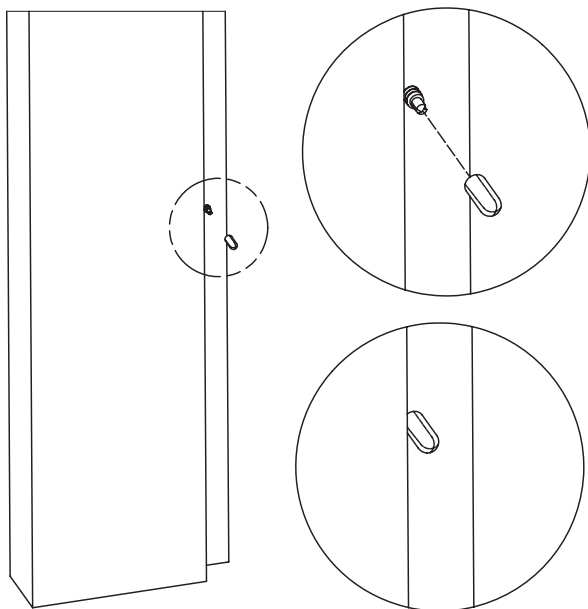

- Screw heads for the Axiom molding to wall attachment and Blades panels to Axiom molding may be visible based on spacing of Blades panels and viewing angle. Touch-up paint (provided by contractor) to match the Axiom molding and embedded hardware can be used in these scenarios.
- Blades panels should not be installed with less than 2" between ends.
- Minimum spacing between rows of Blades panels is 6" O.C.
- Spacing between rows and depth of the Blades panels may require a progressive installation.

5.0 FLOATING PERIMETER/ TRIM FOR DISCONTINUOUS SYSTEMS

For discontinuous grid installations Axiom trim can be used to provide a professional, finished aesthetic around the grid.

It is recommended that Axiom interfaces at the grid level, because SoundScapes® Blades™ hang at various elevations below the face of the grid system.

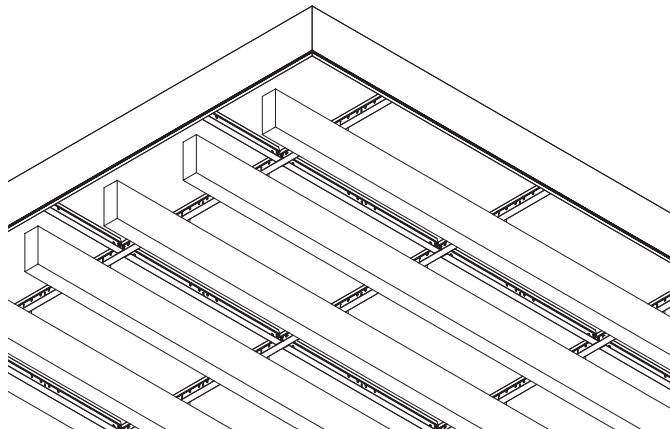

6.0 TRANSITIONS

SoundScapes Blades can be installed adjacent to other ceiling types or in conjunction with other ceilings. Transitions to a SoundScapes Blades installation can be made similarly to a traditional acoustical grid ceiling but must account for the elevation drop of the Blades panels below the suspension system.

7.0 BLADES PANEL ATTACHMENT TO SUSPENSION SYSTEM

The Blades panels can be installed by aligning the embedded attachment clip into the rout holes in the Prelude® XL® main beams. The 6" O.C. rout holes in the suspension system act as alignment and spacing indicators. Additional measuring and modifying of the suspension or embedded attachment clip is necessary when installing Blades panels off the 6" O.C. rout holes. In cases where the clip does not align with a rout hole, the clip can be modified and screw-attached as detailed in the following note:

Always consider load and swinging of vertical panels for any installation type. A 6" O.C. minimum spacing is recommended for all standard SoundScapes Blades panels installed on a Prelude XL suspension system.

1. Align the clip tabs on the embedded hardware in the appropriate rout holes of the suspension system.
2. Once the tabs are engaged, Blades panels will be level and ready to secure to the suspension system.
3. Attach to the suspension system with a short framing screw through the clip convenience hole and the web of the grid. One screw per Blades panel if the installation is Seismic Category A or B. One screw at each hardware-to-suspension connection if the installation is Seismic Category C, D, E, or F.



NOTE: In order to install Blades™ panels in a location where a rout hole is not present to accept the clip tab, use aviation snips to cut off the tab on the embedded hardware so that the remaining hardware can press firmly against the web of the suspension system. Once aligned, simply drive a short framing screw through each clip convenience hole at the location desired along the suspension system component.

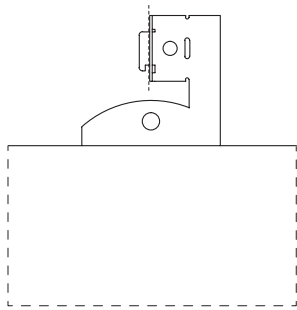

7.1 Attached to Axiom® Molding That is Directly Attached to Ceiling Structure

SoundScapes® Blades™ 5" panels can be directly attached to Axiom molding that is fastened to structure using the following components:

- Axiom molding (AXM34STR3XX)
- Fasteners for Blades panels to molding attachment (#8 x 7/16" self-drilling wafer headscrews, provided by contractor).
- Appropriate fastener for Axiom molding to structure connection (provided by contractor).

Refer to Sections 4.5.2 and 4.6.2 for more details.

8.0 SPECIAL INSTALLATION CONSIDERATIONS

8.1 Sloped Installations

The following rules apply to sloped installations for SoundScapes Blades and are based on the installation method:

Independent Suspension with Hanging Kit

Blades panels should not be sloped and are intended for the bottom edge to be on a horizontal plane. This applies to all Seismic Design Categories

Attached to Prelude® Grid

Blades panels should not be installed on sloped grid. This applies to all Seismic Design categories.

Directly Attached to Axiom Molding

When directly attached to Axiom molding, Blades panels can be installed on up to a 30-degree slope as long as the Blades panels and Axiom molding are running up the slope.

Ceilings with a slope angle >30 degrees require project specific engineering, which is the design team's responsibility. This applies to all Seismic Design categories.

8.2 MEP Integration

Mechanical fixtures such as lights, speakers, and sprinklers should be installed into the acoustical suspension system before installing the SoundScapes Blades panels. Fixtures can be installed at the suspension system height or flush with the bottom of the panels (refer to Section 1.5 for sprinkler considerations). Fixture weight or housing must not be supported by the Blades panels.

8.3 Exterior Installations

SoundScapes Blades cannot be installed in exterior installations.

9.0 SEISMIC INSTALLATIONS

The following are modifications to installations that are Seismic Category C, D, E or F.

For more details on seismic installations please see our brochure: Seismic Design: What You Need to Know <https://www.armstrongceilings.com/content/dam/armstrongceilings/commercial/north-america/brochures/seismic-design-what-you-need-to-know-brochure.pdf>

9.1 Aircraft Cable Installation

The International Building Code states the ceiling system connection to structure must allow the ceiling to move 360° in horizontal plane. Blades panels suspended individually with aircraft cable must be spaced a minimum of 12" apart or from surrounding surfaces to avoid contact during a seismic event.

9.2 Grid Suspension System:

- All seismic installations of SoundScapes Blades panels must be installed per Seismic Categories D, E, F. This is regardless of the total system weight.
- Prelude® Heavy-duty grid is required per ASTM E580 and the cross tees may have to match the mains in load-carrying capacity based on the grid layouts as defined in Section 4.
- SoundScapes Blades directly attached to grid have been engineered for application in all seismic areas.
- One screw is required at each embedded hardware-to-grid connection.

9.3 Seismic Rx® Category D, E and F Requirements (All Seismic Installations)

- Blades panels must be spaced a minimum of 6" O.C. apart and from surrounding surfaces to avoid contact during a seismic event.
- Ceiling installation should conform to basic minimums established in ASTM C636.
- Minimum 7/8" wall molding.
- Suspension system must be attached on two adjacent walls.
- Opposite walls require BERC2 with 3/4" clearance.
- BERC2 maintains main beam and cross tee spacing; no other components required.
- Heavy-duty systems as identified in ICC-ESR-1308
- Safety wires required on light fixtures.
- Perimeter support wires within 8"
- Ceiling areas over 1,000 SF must have horizontal restraint wire or rigid bracing.
- Ceiling areas over 2,500 SF must have seismic separation joints or full height partitions.
- Ceilings without rigid bracing must have 2" oversized trim rings for sprinklers and other penetrations.
- Changes in ceiling plane must have positive bracing.
- Cable trays and electrical conduits must be independently supported and braced.
- Suspended ceilings will be subject to special inspection.
- Suspension layouts

- Suspension layouts are the same as described in Section 4.4: Suspension System.
- Connection to wall – See BPCS-4141 Seismic Design: What You Need to Know – Code Requirements Seismic Rx® Tested Solutions – SEISMIC RX APPROACHES TO CATEGORY C and D, E, AND F INSTALLATIONS.
- Special bracing required – See BPCS-4141 Seismic Design: What You Need to Know – Code Requirements Seismic Rx Tested Solutions – Bracing and Restraint for Seismic Installations.

- Seismic separation joints – See BPCS-4141 Seismic Design: What You Need to Know – Code Requirements Seismic Rx Tested Solutions – Seismic Separation Joints.

Seismic reaction information is based on full-scale testing and computer modeling conducted at the Structural Engineering Earthquake Simulation Lab located at the State University of New York at Buffalo.

DIRECT-ATTACH INSTALLATION

- 1) Using metal snips, cut the SoundScapes® Blades™ hardware and the Axiom® molding to the desired length (matching the length of the Blades™ panel looks great!)

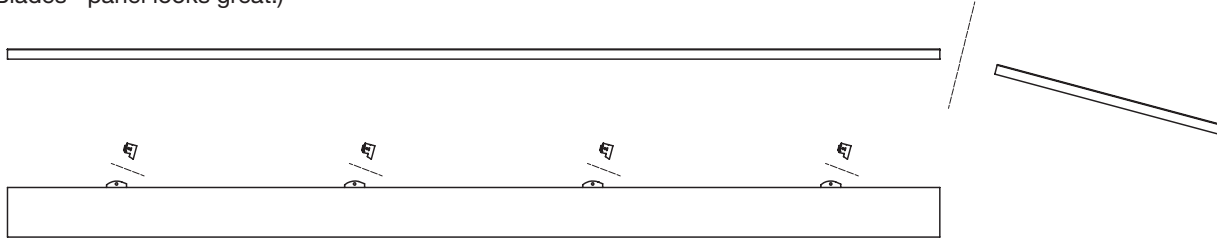

- 2) After marking specified location of the Blades panel on the wall or ceiling, attach the 3/4" face of the Axiom molding using appropriate fasteners for the surface type.

Drywall screw anchors will work well when studs aren't easily located.

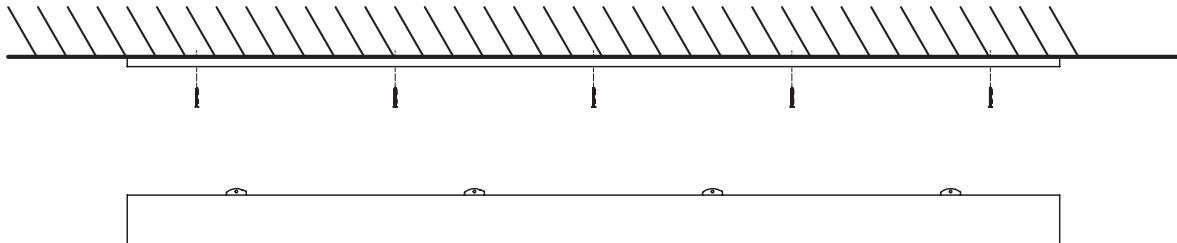

- 3) Lastly, screw the SoundScapes Blades panel hardware to the 1" surface of the Axiom molding. Consider coordinating screw color to match the 360° degree painted Axiom molding!

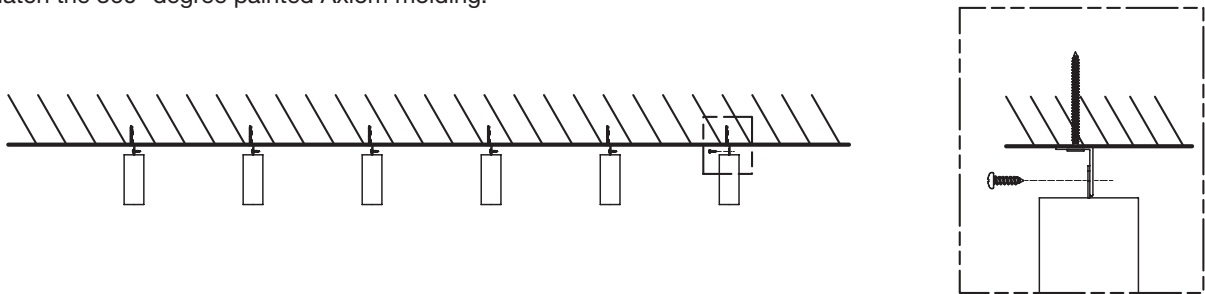

This document is also available in Spanish and French on our website.

Este documento está disponible en español y en francés en nuestro website.

Ce document est également disponible en espagnol et en français sur notre site web.

MORE INFORMATION

For more information, or for an Armstrong Ceilings representative, call 1 877 276 7876.

For complete technical information, detail drawings, CAD design assistance, installation information, and many other technical services, call TechLine customer support at 1 877 276 7876 or FAX 1 800 572 TECH.

For the latest product selection and specification data, visit armstrongceilings.com/soundscapesblades.

Sherwin-Williams® is a registered trademark of The Sherwin-Williams Company; Inspiring Great Spaces® is a trademark of AFI Licensing LLC. All other trademarks used herein are the property of AWI Licensing LLC and/or its affiliates © 2018 AWI Licensing LLC • Printed in the United States of America

BPLA-297844-218

Armstrong
CEILING SOLUTIONS