

FELTWORKS® Acoustical Panels

Assembly and Installation Instructions

1. GENERAL

1.1 Product Description

FELTWORKS® Acoustical Panels are 1" thick (nominal), available in a standard size of 48" x 96", and offer acoustical absorption to control noise in a wide range of applications. Standard panels are available in Black, White, Light Grey, Dark Grey, and Beige. Custom sizes up to 54" x 120" are available. FELTWORKS Acoustical Panels can be installed using screws and washers, glue, or magnets, and can be attached to Armstrong® Drywall Grid, furring (wood or metal), painted drywall, or direct to a metal deck. (Fig 1)

1.2 Safety

1.2.1 Be certain that the work site is well ventilated during the installation and avoid breathing in any dust from field cutting panels. If high dust levels are anticipated during installation, such as with the use of power tools, use appropriate NIOSH designated dust respirators. All power cutting tools must be equipped with dust collectors. Avoid contact with skin or eyes. Wear long sleeves, gloves, and eye protection.

1.2.2 Please use caution when using the adhesive if you are using the Direct-Applied installation method. Follow the first aid measures in the manufacturer's Safety Data Sheet if glue comes in contact with your skin or eyes, or is inhaled or ingested.

1.2.3 NOTE: FELTWORKS panels may be installed with magnets, in projects where fasteners should not be visible. While rare earth neodymium magnets are commonly used in commercial applications, individuals with pacemakers, ICDs, or other implanted medical devices must use caution as magnets can impact performance of these devices. Consult a physician for specific details.

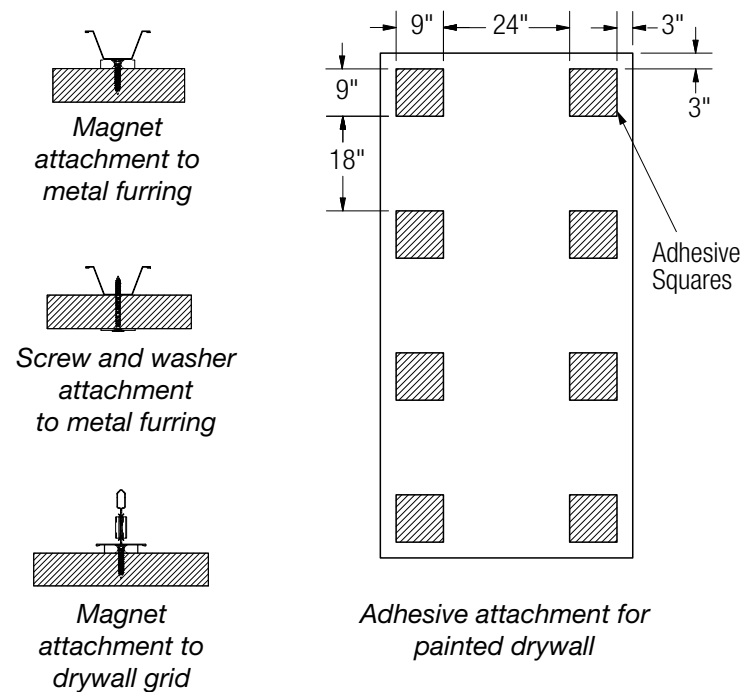

(Fig 1)

1.3 Warranty

Failure to follow the Armstrong Ceilings recommended installation instructions in effect at the time of installation may void the product and/or ceiling system warranty. See website for most up-to-date instructions.

1.4 Surface Finish

FELTWORKS Acoustical Panels are made of non-woven layered and formed polyester felt (PET) fibers. This is a color throughout product.

1.5 Storage & Handling

1.5.1 Panels should be stored in a dry interior location and shall remain on the pallet prior to installation to avoid damage. The pallet should be stored in a flat, horizontal position. Proper care must be taken when handling to avoid damage and soiling. Do not store in unconditioned spaces with relative humidity greater than 85% or lower than 25%, and temperatures lower than 32°F or greater than 120°F. Panels must not be exposed to extreme temperatures, for example, close to a heating source or near a window where there is direct sunlight.

1.5.2 The 48" x 96" panels may require two people for proper handling and installation.

1.5.3 White cotton or latex gloves are recommended for handling.

1.5.4 If using the Direct-Applied (adhesive) installation method, the area of installation, adhesive, and panels should be conditioned at 65°F (18°C), or above, for 48 hours prior, during, and 48 hours after the installation is complete. Please also consult adhesive manufacturer's instructions.

1.6 Site Conditions

Building areas to receive ceilings shall be free of construction dust and debris. This product is not recommended for exterior applications where standing water is present, or where moisture will come into direct contact with the ceiling.

1.7 HVAC Design & Operation, Temperature & Humidity Control

It is necessary for the area to be enclosed and for the HVAC systems to be functioning and in continuous operations for the life of the product. All wet work (plastering, concrete, etc.) must be complete and dry prior to installation. Panels cannot be field painted.

1.8 Colors

1.8.1 Panel Colors

FELTWORKS Acoustical Panels are available in Black, White, Light Grey, Dark Grey, and Beige. Panels have color throughout. Panels may vary slightly in color and texture due to material variations. To maximize visual consistency, panels should be unpacked and examined collectively to determine the most desirable arrangement for installation.

1.8.2 Field Painting Hardware Accessories

Visible hardware (screws and washers) is available in Black and Mill Finish (paintable). We recommend the following Sherwin-Williams® colors to coordinate with our five standard colors if the hardware (screws and washers) will be painted in the field. Field painting the panels will void the product warranty.

- Black: Sherwin-Williams 6258 – Tricorn Black
- White: Sherwin-Williams 7007 – Ceiling Bright White
- Light Grey: Sherwin-Williams 7663 – Monorail Silver
- Dark Grey: Sherwin-Williams 7674 – Peppercorn
- Beige: Sherwin-Williams 7512 – Pavilion Beige

1.9 Cleaning/Maintenance

Use a clean, dry, soft, white cloth to wipe off any dust or fingerprints. A vacuum can also be used to remove dirt from the panels. Vacuum cleaner brush attachments, such as those designed for cleaning upholstery or walls, do the best job. Be certain to clean in one direction only to prevent rubbing dust into the face of the panel. If this does not clean the panel, use a damp, clean, soft, white cloth or sponge with a mild detergent to wipe the panel. Remove any remaining moisture with a dry cloth.

2. DESIGN CONSIDERATIONS

2.1 Directionality

There is a natural fiber direction in the FELTWORKS Acoustical Panels. It is recommended to install the panels in the same fiber direction. Directionality will be marked on the back of the panels.

2.2 Exterior Installations

FELTWORKS Acoustical Panels are not intended for exterior use.

2.3 Direct Attachment

FELTWORKS Acoustical Panels can be attached to Armstrong Drywall Grid, furring (wood or metal), painted drywall, or direct to a metal deck with the fasteners listed in this document.

2.4 Proximity to Diffusers/HVAC Systems

Panels may accumulate dust if placed near a diffuser or HVAC system. Please consider this when designing the space. If dust or dirt does accumulate, see Section 1.9 for cleaning recommendations.

2.5 Panel Spacing

The recommended panel spacing will depend on the installation method. Armstrong is unable to warrant the visual of the installation when panels are installed with a panel-to-panel reveal of less than 2". See below for details:

Direct-Attached (screw & washer)

- Attaching to Armstrong® Drywall Grid: There will be an 8" gap in between long panel edges. This is due to the rout hole spacing on the Armstrong Drywall Grid.
- Attaching to Furring Channel: It is recommended to have a 2" gap in between the panel edges.

Direct-Applied – Adhesive installation

- It is recommended to have a 2" gap in between the panel edges.

Magnet

- Attaching to Armstrong Drywall Grid: There will be an 8" gap in between long panel edges. This is due to the 8" rout hole spacing on Armstrong Drywall Grid.
- Attaching to Furring Channel: It is recommended to have a 2" gap in between the panel edges.
- Attaching directly to Metal Deck: It is recommended to have a 2" gap in between the panel edges.

2.6 Plenum

Design considerations require relatively clear and clean deck areas for most attachment methods. We recommend using a suspended drywall grid installation if your plenum space contains services or obstructions that interrupt the attachment surface. Due to material chemistry, FELTWORKS® Acoustical Panels are classified as a combustible material in the International Building Code. Panels installed below obstructions using drywall grid may create a return air plenum, based on depth from the deck. Please consult fire protection engineer or local code official for guidance.

2.7 Fire and Sprinklers

Installations may require sprinklers above and below the panels if a plenum is present. Please consult a fire protection engineer, NFPA 13, and the local codes for guidance.

2.8 Panel Face Offset

The face of the FELTWORKS Acoustical Panel extends 1" or greater below the face of the suspension system based on the installation method. The height of components that interface with the ceiling panels, such as sprinkler heads and light fixture trim rings, will have to be adjusted to accommodate this offset.

2.9 Area Preparation

2.9.1 Surfaces must be dry and free of dust, grease, oil, dirt, or any other material that may deter adhesion when using the Direct-Applied installation method with adhesive. Existing finish paint must be well-bonded and not flaking or peeling; otherwise it must be removed. Avoid applying to a newly painted ceiling/deck. Glossy painted surfaces must be abraded. For painted or sealed surfaces, install a small test area and observe after 12 hours.

2.9.2 Surfaces must be dry and free of dust, grease, oil, dirt, or any other material that may deter adhesion when using the magnet installation method and attaching the panels directly to the metal deck. Surfaces must also be free of any obstructions (i.e. screws, hooks, wires, etc.).

2.10 Accessibility

The FELTWORKS Acoustical Panels can be accessible if installed with the magnet installation method. If building maintenance needs to move the panels after installation is complete, make sure the screw and magnet connection points are secure in the panels before reinstalling.

3. FELTWORKS ACCESSORIES

Armstrong Ceiling and Wall Solutions cannot guarantee the product's performance if accessories beyond those listed in this document are used.

3.1 Screws

Armstrong® Ceiling and Wall Solutions offers two types of screws for many common installation methods. Please see Section 4 for specific installation instructions.

- Screw to drywall grid and furring: #8 x 1-7/8" Screw to be used with the washer (Item 6489 __, available in Mill Finish (MF) and Black (BL) (Fig 2)
- Screw used with magnet: #8 x 1" Flat Head Screw (Item 6527) (Fig 3)

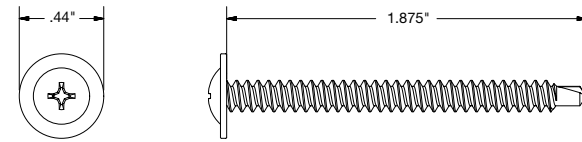

(Fig 2)

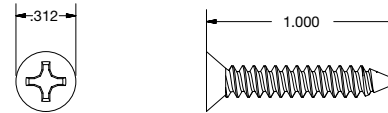

(Fig 3)

3.2 Washers

Armstrong Ceiling and Wall Solutions offers a 1" flat washer for screw size #8 when using the Direct-Attached installation method. The washer should be used with the #8 1-7/8" Flat Head Screw, as referenced in Section 3.1. Item 6488 __, available in Mill Finish (MF) and Black (BL) (Fig 4)

3.3 Magnets

Armstrong® Ceiling and Wall Solutions recommends a 1" x 1/4" neodymium magnet with a countersunk hole when using the magnet installation method. The magnets will need to be ordered separately and they will need to be field-applied to the back of the panel before installation. The magnets have a countersunk hole in the center to allow for screw attachment to the panel. The magnets have an approximate pull force of more than 24 lbs (Item 6526).

IMPORTANT NOTE: FELTWORKS® panels may be installed with magnets, in projects where fasteners should not be visible. While rare earth neodymium magnets are commonly used in commercial applications, individuals with pacemakers, ICDs, or other implanted medical devices must use caution as magnets can impact performance of these devices. Consult physician for specific details. The magnets are a potential pinch hazard due to their natural strength. It is recommended to use gloves when handling the magnets. (Fig 5)

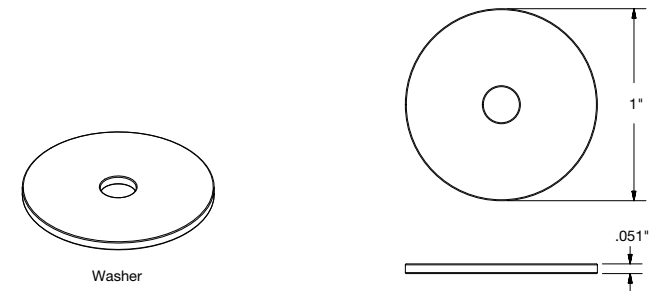

(Fig 4)

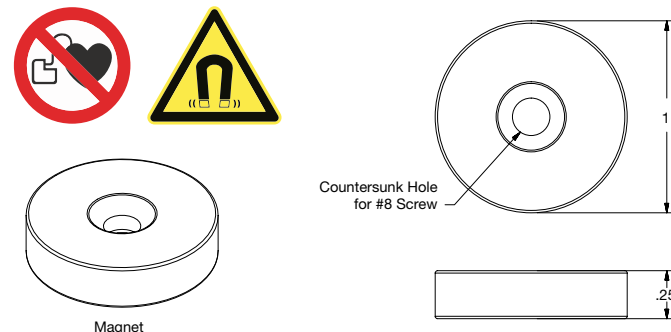

(Fig 5)

3.4 Adhesive

- Armstrong Ceiling and Wall Solutions recommends Titebond® GREENchoice or Henry® 237 AcoustiGum™ Acoustical Ceiling Tile Adhesive when using the direct-applied installation method. The adhesive will be supplied by the contractor.

- Armstrong Ceiling and Wall Solutions recommends Original Gorilla Glue® (or equal polyurethane foam adhesive) when using the magnet installation method. The Original Gorilla Glue® (or equal) will be supplied by the contractor.

3.5 QuickStix™ Uptight Clip (QSUTC)

Installations using Armstrong® Drywall Grid may require the QSUTC for attachment to the deck. The minimum distance from the deck to the face of the grid when using the QSUTC is 1-3/4" and can adjust up to 5-1/2" to account for unevenness in the surface. **(Fig 6)**

Each QSUTC requires secure attachment to structure (specified by contractor based on deck material) and two framing screw attachments from the clip to the grid.

For flat installations:

- Each 12' main runner requires (3) QSUTC attachments to deck spaced no further than 6' O.C.
- All drywall mains must have a QSUTC attachment within 12" of each clip and within 3" of the fire expansion notch.

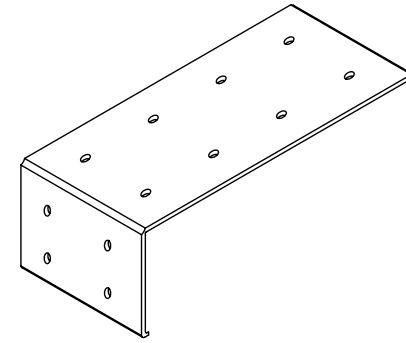

(Fig 6)

4. INSTALLATION OPTIONS

4.1 Direct-Attached (screw & washer installation)

FELTWORKS Acoustical Panels can either attach to Armstrong® Drywall Grid or furring. Both methods are explained in more detail below.

4.1.1 Hardware Layout

The following rules apply for all Direct-Attached panels:

- Each 48" x 96" panel requires twelve screws (Item 6489 _ _).
- Each screw is placed 8" in from the long panel edge. The screws located at the ends of the panel are placed 9" in from the nearest short panel edge. **(Fig 7)**
- Exact screw spacing is based on alignment with the suspension, but it should target 26" O.C. between screws along the length of the panel and 16" O.C. between screws across the width of the panel.

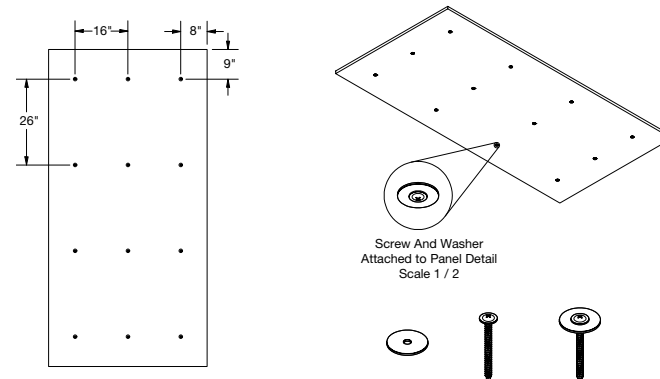

(Fig 7)

Panel Spacing

Armstrong is unable to warrant the visual of the installation when panels are installed with a panel-to-panel reveal of less than 2".

- Attaching to Drywall Grid: There will be an 8" gap in between long panel edges. This is due to the 8" rout hole spacing on Armstrong Drywall Grid.
- Attaching to Furring: It is recommended to have a 2" gap in between the panel edges.
- Hardware spacing may change if panels are cut in the field. Refer to Section 5.2.6 for repositioning guidelines.

4.1.2 Armstrong Drywall Grid

Installations using Armstrong Drywall Grid will require:

- 12' Drywall Grid main beam (HD8906)
- 4' Drywall Grid cross tee (XL8945)
- QuickStix Uptight Clips (QSUTC) (layout dependent)

Attachments of the drywall grid to the deck can be made with the QSUTC Uptight Clip. See Section 3.5 for attachment rules and spacing.

The drywall grid should be leveled to within 1/4" over 10' (ASTM C636) to ensure a satisfactory visual.

Layout Considerations

- Panels will be installed short edge-to-short edge and will require three rows of suspension. Suspension is installed parallel to the 96" length of the panels.
- Three rows: the drywall grid will be placed at 16" O.C. for the attachment of the panel hardware. (Fig 8)

Panel Spacing

Armstrong is unable to warrant the visual of the installation when panels are installed with a panel-to-panel reveal of less than 2". There will be an 8" gap in between long panel edges. This is due to the 8" rout hole spacing on Armstrong® Drywall Grid.

4.1.3 Metal or Wood Furring

Furring for FELTWORKS® Acoustical Panels can be either wood or metal. For steel channel/hat channel, Armstrong® Ceiling and Wall Solutions recommends 20-gauge 7/8" galvanized steel furring; however, ranges of 20- to 25-gauge metal furring can be used. For wood furring, 3/4" x 1-1/2" or 3/4" x 2-1/2" is recommended.

The furring must be attached to the structure in a method that supports the full weight of the panels. Armstrong Ceiling and Wall Solutions does not provide guidance regarding the attachment of furring to structure and is therefore not liable for any damage or installation complications

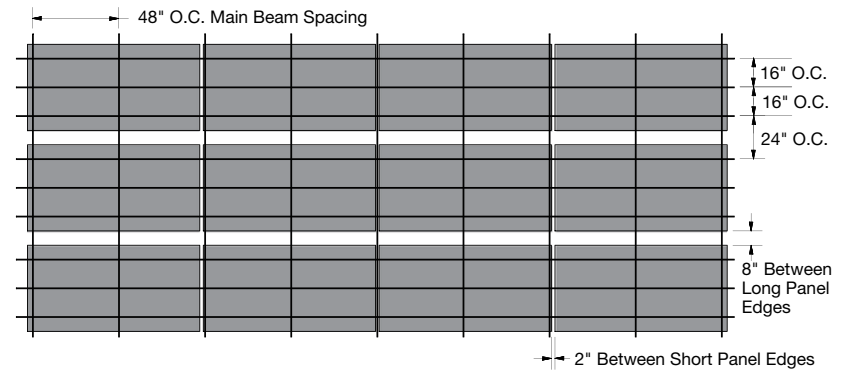

(Fig 8)

that may occur from an improper installation of furring. Please refer to the manufacturer's instructions for guidance on the attachment of the furring to structure. The furring should be leveled to within 1/4" over 10' (ASTM C636) to ensure a satisfactory visual.

The spacing and structural components in the deck may vary so it is recommended to use an alignment method that can operate independently from these components (i.e. laser, chalk line).

You have more flexibility when using metal furring since you are not limited to the rout hole spacing as you are when using drywall grid.

Panel spacing

It is recommended to have a 2" gap in between the panel edges.

Layout Considerations

- Panels with short edges installed with a 2" gap between require three rows of suspension. Suspension is installed parallel to the 96" length of the panels. Due to the recommended 2" gap in between panels, your furring layout will follow a pattern: 16" O.C., 16" O.C., and 18" O.C. (Fig 9)
- Panels with long edges installed with a 2" gap between require four rows of suspension. Suspension is installed perpendicular to the 96" length of the panels. Due to the recommended 2" gap in between panels, your furring layout will follow a pattern: 26" O.C., 26" O.C., 26" O.C., and 20" O.C. (Fig 10)
- The suspension should be cut 1" – 7" short of the desired panel edges where the rows start and end to avoid visibility of the suspension. (Fig 11)

4.1.4 Attachment to Drywall Grid or Furring

- Once your layout is planned, plot and insert the screws (Item 6489_) and washers (Item 6488_) to the front of the panel. Pre-setting the screws and washers will expedite installation, as well as ensure that the fasteners are in the correct location.
- The panels are then carefully lifted to the grid/furring. It is recommended that the 48" x 96" panels are handled by two people.
- Support the panels as the screws and washers are installed using a standard impact driver or drill/driver.

If installing using drywall grid, clamps can be used to hold the panel to the grid. It is recommended to use Locking C-Clamp Vise Grips or Ratcheting Spring Clamps, but not a steel spring clamp, since they can indent the face of the panel.

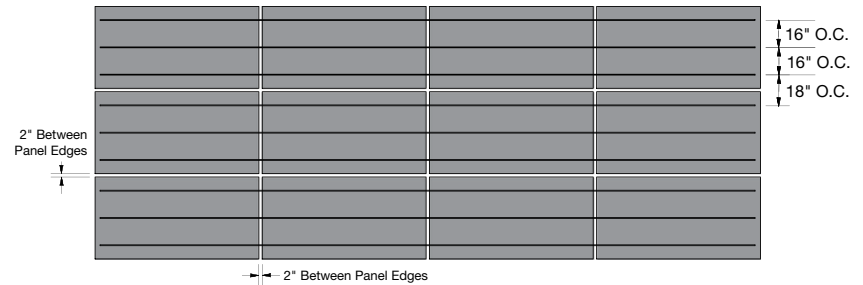

(Fig 9)

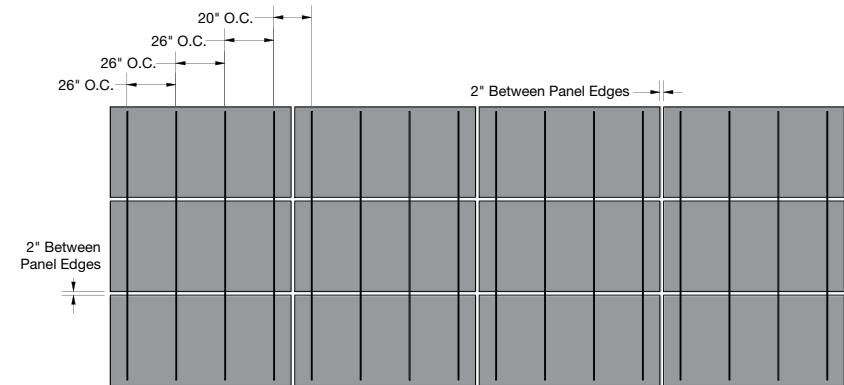

(Fig 10)

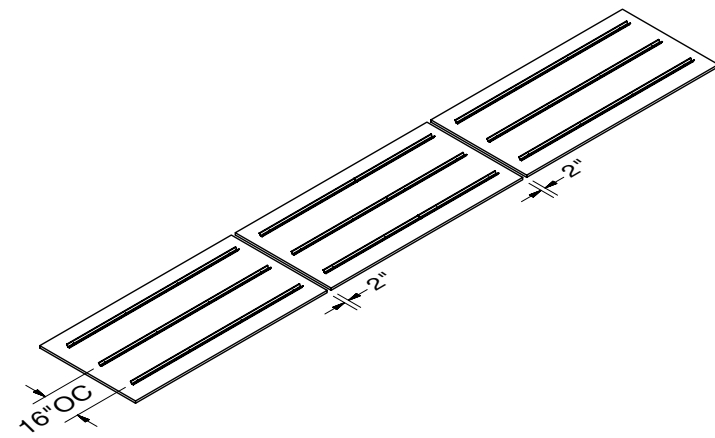

(Fig 11)

IMPORTANT NOTE: fasteners should be set to a depth of no more than flush with the face of the panel. Over tightened fasteners will indent the face of the panel and will cause a pillowing effect. If fasteners are over tightened, back the fastener out of the grid/furring until the pillowing goes away, while making sure the fastener is still engaged to the grid or hat channel. (Fig 12)

- It is recommended to practice installing the fasteners on scrap pieces of panel to ensure proper depth is achieved.

4.1.5 Field Painting Screws and Washers

We recommend the following Sherwin-Williams® colors to coordinate with our five standard colors if the hardware will be painted in the field. Field painting the panels will void the product warranty.

- Black: Sherwin-Williams 6258 – Tricorn Black
- White: Sherwin-Williams 7007 – Ceiling Bright White
- Light Grey: Sherwin-Williams 7663 – Monorail Silver
- Dark Grey: Sherwin-Williams 7674 – Peppercorn
- Beige: Sherwin-Williams 7512 – Pavilion Beige

4.2 Direct-Applied (Adhesive) to Painted Drywall

4.2.1 Armstrong® Ceiling and Wall Solutions recommends Titebond® GREENchoice or Henry® 237 AcoustiGum™ Acoustical Ceiling Tile Adhesive when using the direct-applied installation method. The adhesive will be supplied by the contractor. The glue provides a secure bond and does not require any supplemental mechanical attachment as long as these instructions are followed.

4.2.2 Using a trowel with 1/4" x 1/2" x 1/4" notches, apply the adhesive to the locations (as shown below) per the panel size you are using. An adhesive spot should be no less than 9" x 9" in size, and it should be no more than 3" away from the edge of the panel. A 48" x 96" will receive eight glue spots of 9" x 9". (Fig 13)

4.2.3 It is recommended to use an alignment method (i.e. laser, chalk line) to make sure the panels are properly positioned during installation.

4.2.4 Once in position, push the panel against the drywall applying even hand pressure to the panel where the adhesive is located, starting at the center first, and then working to the edges. By attaching the center first, the installer can still pivot the panel slightly left or right before adhering the edges. This ensures that the panel can be aligned correctly first before the edges are solidified into place. Avoid excessive pressure to minimize panel flexing that will disturb the previously pressed areas of adhesive and result in release of the adhesive. Lastly, press a sponge float across all areas of the panel where glue was applied to ensure all glue spots are properly compressed and adhered to the drywall.

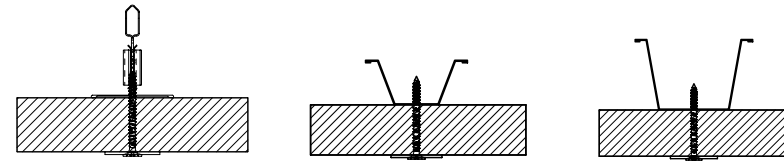

(Fig 12)

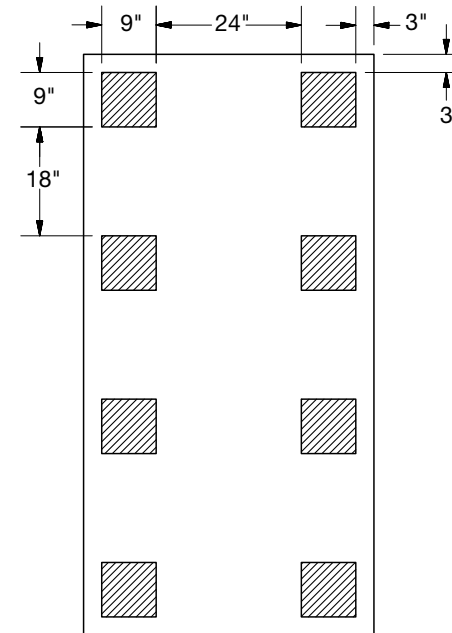

(Fig 13)

4.2.5 Any slight adjustments to the panel placement should be done immediately so as to not weaken the adhesive bond. Once the panel is evenly pressed into position, the adhesive should provide an immediate bond to hold the panel in place while the adhesive sets.

4.2.6 It is recommended to have 2" of space between all panel sides.

4.3 Magnet Installation Option

4.3.1 Hardware Layout

We recommend two different hardware layouts based on the seismic category of the project.

- For non-seismic installations, the panels will require 12 magnets.
- For seismic installations, the panels will require 15 magnets.

4.3.1.1 Magnet Installation - Non-Seismic

- Each 48" x 96" panel requires twelve magnets in three rows per the detail below (Item 6526).
- Each magnet has a countersunk hole in the center to allow for screw attachment to the panel. Use the #8 x 1" Screws with the magnets, as specified in Section 3.3 (Item 6527).
- Each magnet is placed 8" in from the long panel edge. The magnets located at the ends of the panel are placed 9" in from the short panel edge. (Fig 14)
- Exact magnet spacing is based on alignment with the suspension, but it should target 26" O.C. between magnets along the length of the panel and 16" O.C. between magnets across the width of the panel.

Panel Spacing

- Attaching to Drywall Grid: There will be an 8" gap in between long panel edges. This is due to the 8" rout hole spacing on Armstrong® Drywall Grid.
- Attaching to Furring Channel: It is recommended to have a 2" gap in between the panel edges.
- Attaching Directly to Metal Deck: It is recommended to have a 2" gap in between the panel edges.
- Hardware spacing may change if panels are cut in the field or ordered in a custom size. Refer to Section 5.2.6 for repositioning guidelines.

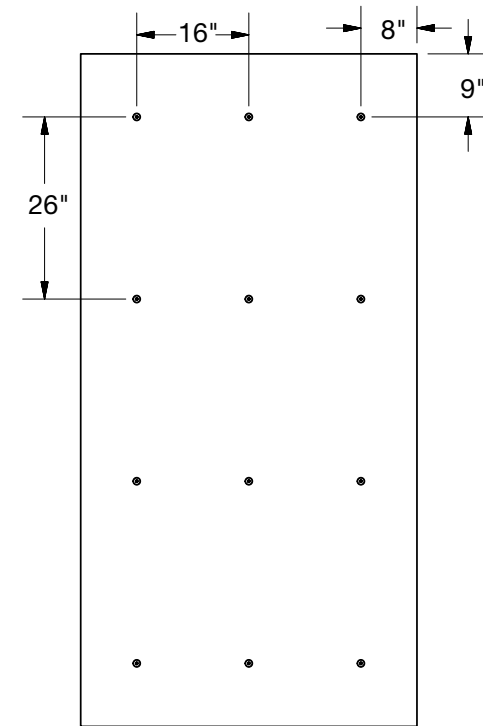

(Fig 14)

4.3.1.2 Magnet Installation – Seismic Area D, E, or F

- Each 48" x 96" panel in seismic areas D, E, or F requires 15 magnets in three rows (Item 6526).
- Each magnet has a countersunk hole in the center to allow for screw attachment to the panel. Use the #8 x 1" screws with the magnets, as specified in Section 3.3 (Item 6527).
- Each magnet is placed 8" in from the nearest panel edge. (Fig 15)
- Exact magnet spacing is based on alignment with the suspension, but it should target 20" O.C. between magnets along the length of the panel and 16" O.C. between magnets across the width of the panel.
- See panel spacing details in Section 4.3.1.1 for layout recommendations.
- Hardware spacing may change if panels are cut in the field or ordered in a custom size. Refer to Section 5.2.6 for repositioning guidelines.

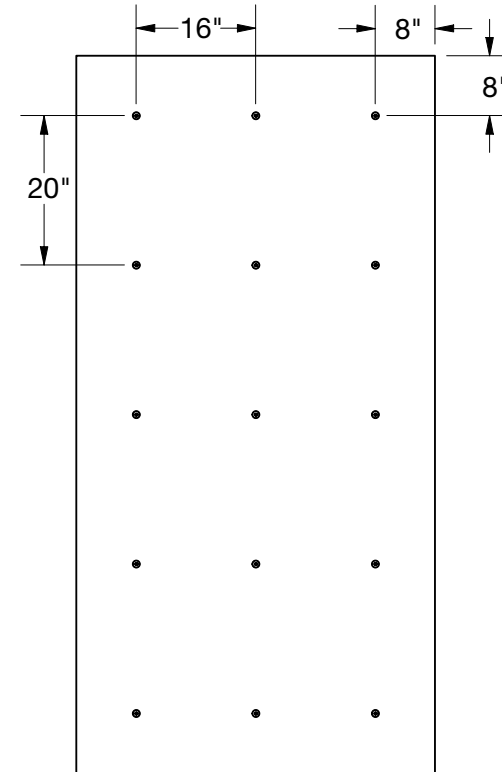

(Fig 15)

4.3.2 Magnet Installation Direct to a Metal Deck

4.3.2.1 The layout of the panels will be dependent upon the ribbing in the metal deck. The exact magnet spacing will be based on the alignment with the metal ribs, as well as the seismic area factors explained in Section 4.3.1. Follow the magnet spacing per Section 4.3.1 based on the determined criteria.

4.3.2.2 The spacing and structural components in the deck may vary so it is recommended to use an alignment method that can operate independently from these components (i.e. laser, chalk line).

4.3.2.3 Once your layout is planned, plot your attachment points to the back of the panel. Add a dab (the size of a screw head) of Original Gorilla Glue® (or equal polyurethane foam glue) on top of those attachment points and screw the magnets through the glue to the back of the panel. The magnet should be flush with the back of the panel – be sure not to over tighten. Now attach the panel to the metal deck. It is recommended that the 48" x 96" panels are handled by two people.

NOTE: the glue may seep through the countersunk hole in the magnet as it cures, so it is not recommended to stack panels once the screw and magnet are attached for 24 hours. This is to prevent a transfer of glue to the face of another panel.

4.3.2.4 It is recommended to have 2" of space between all panel sides.

4.3.3 Direct to Armstrong® Drywall Grid or Metal Furring

4.3.3.1 The FELTWORKS® Acoustical Panels can be attached directly to Armstrong Drywall Grid and galvanized steel furring with the use of magnets. Aluminum furring cannot be used as it is not a magnetic material.

4.3.3.2 The drywall grid or furring should be leveled to within 1/4" over 10' (ASTM C636) to ensure a satisfactory visual.

4.3.3.3 The spacing and structural components in the deck may vary so it is recommended to use an alignment method that can operate independently from these components (i.e. laser, chalk line).

4.3.3.4 The exact magnet spacing will be based on the alignment with the metal drywall grid or metal furring, as well as the seismic area factors explained in Section 4.3.1. Follow the magnet spacing explained in Section 4.3.1 based on the determined criteria.

4.3.3.5 Drywall Grid and Metal Furring Layouts

Drywall Grid

- Armstrong Drywall Grid has rout holes spaced every 8" O.C. Regardless of the criteria explained in Section 4.3.1, you will have three rows of hardware, and your drywall grid cross tees will follow a pattern: 16" O.C., 16" O.C., and 24" O.C.
- Panel Spacing: There will be an 8" gap in between long panel edges. This is due to the 8" rout hole spacing on Armstrong Drywall Grid.
- Layout Considerations: Adjoining panels must be installed short edge-to-short edge. (Fig 16)

Metal Furring

- You have more flexibility when using metal furring since you are not limited to the rout hole spacing as you are when using drywall grid.
- Panel spacing: It is recommended to have a 2" gap in between the panel edges.
- Layout Considerations: Rows with short edge of panels installed 2" from next panel's short edge require three rows of suspension. Suspension is installed parallel to the 96" length of the panels. Due to the recommended 2" gap in between panels, your furring layout will follow a pattern: 16" O.C., 16" O.C., and 18" O.C. (Fig 17)
- Rows with long edge of panels installed 2" from next panel's long edge will require four or five rows of suspension depending on the seismic category of the installation space. Suspension is installed perpendicular to the 96" length of the panels. Due to the recommended 2" gap in between panels, your furring layout will follow a pattern:
- Four Rows: 26" O.C., 26" O.C., 26" O.C., 20" O.C. (Fig 18)

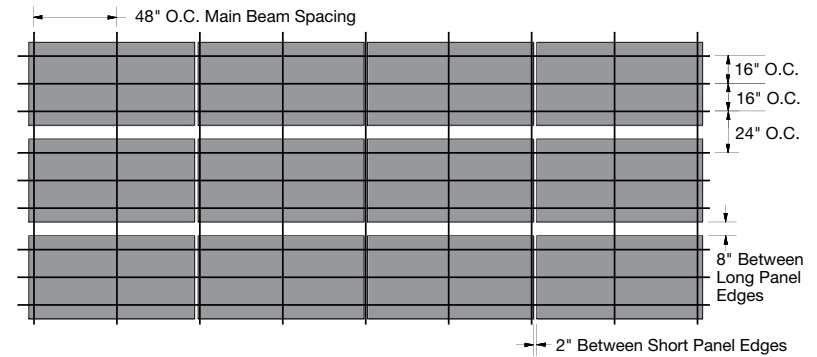

(Fig 16)

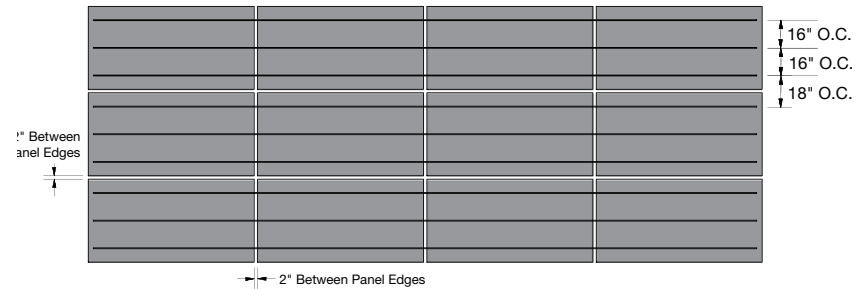

(Fig 17)

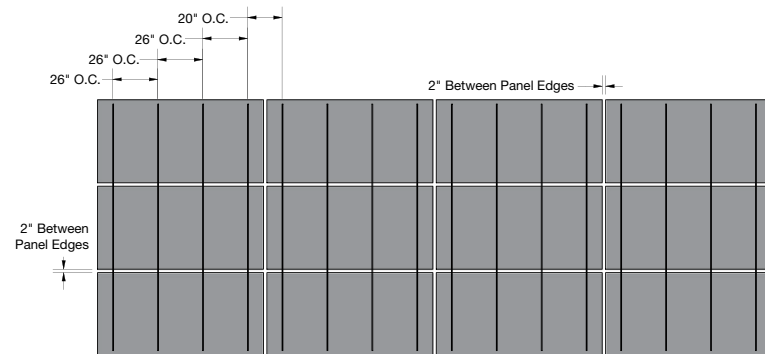

(Fig 18)

- Five Rows: 20" O.C., 20" O.C., 20" O.C., 20" O.C., 18" O.C. (Fig 19)
- The suspension should be cut 1" – 7" short of the desired panel edges where the rows start and end to avoid visibility of the suspension. (Fig 20)

4.3.3.6 Once your layout is planned, plot your attachment points to the back of the panel. Add a dab (the size of a screw head) of Original Gorilla Glue® (or equal polyurethane foam glue) on top of those attachment points and screw the magnets through the glue to the back of the panel. The magnet should be flush with the back of the panel – be sure not to over tighten. Now attach the panel to either the metal drywall grid or galvanized steel furring. It is recommended that the 48" x 96" panels are handled by two people.

NOTE: the glue may seep through the countersunk hole in the magnet as it cures, so it is not recommended to stack panels once the screw and magnet are attached for 24 hours. This is to prevent a transfer of glue to the face of another panel. (Fig 21)

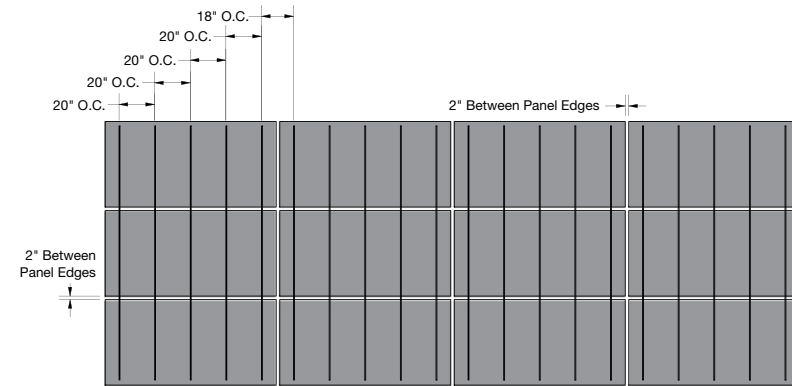

(Fig 19)

5. PANELS

5.1 Edge Detail/Interface

FELTWORKS® Acoustical Panels are 1" thick (nominal) and are available in a standard size of 48" x 96" with all sides having square edges.

5.2 Field Cutting

FELTWORKS Acoustical Panels may be cut with a variety of tools, depending on the type and precision of cut required. No touch up is required due to the color throughout panel design. Tool speeds and the angle of the cut should be such that the panel does not melt from frictional heat. In general, the highest speed at which overheating of the tool or panel does not occur will give best results. It is recommended to test cut with scrap material to determine the best speed and method for cutting.

5.2.1 The following tools can be used to make cuts in the field:

- Table saw: recommended field cutting method for straight cuts. Be sure to use a 7-1/4" foam blade, such as Bullet Tools™ Centerfire™ or equal. Constant feed rate is critical to limit panel melting on the cut edge.
- Jigsaw: recommended for complex cuts such as circles that would need to be made to maneuver around pipes, sprinkler heads, and other fixtures in the field. If a jig saw is to be used for a straight cut, utilize a straight edge to guide the jigsaw to ensure the cut edge remains straight. Be sure to use a foam knife edge blade when using the jigsaw, such as Bosch T313AW or equal.

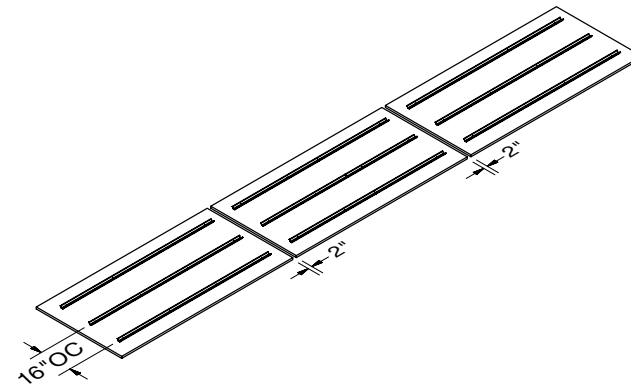

(Fig 20)

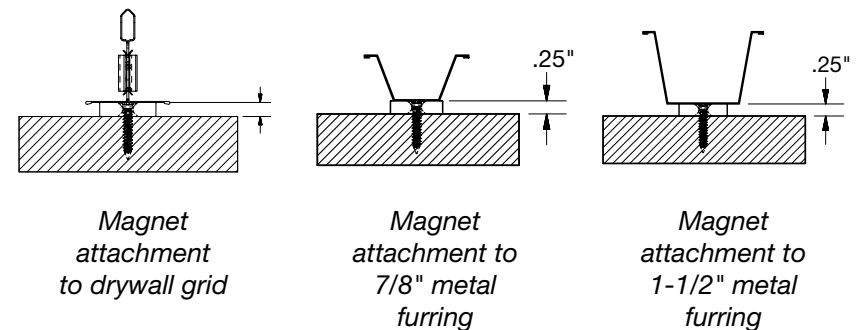

(Fig 21)

- Circular saw: can be used for straight cuts if a table saw is not onsite. Be sure to use a 7-1/4" foam blade, such as Bullet Tools Centerfire or equal, or a non-ferrous/plastic blade, such as Diablo® D0756N or equal. Utilize a straight edge to guide the circular saw to ensure the cut edge remains straight. Constant feed rate is critical to limit panel melting on the cut edge. When using the circular saw, make sure the blade comes to a complete stop before backing the saw out of the cut.
- Hole saw: can be used when circular holes are needed.
- Hand Tools: can be used for straight or circular cuts. Tools that have proven performance include: insulation cutting knife, snap-away utility knife, straight knife. Three to four passes may need to be made to cut through the material. Ensure blade is long enough to cut through the material to prevent poor edge quality. Utilize a straight edge to guide the hand tool to ensure the cut edge remains straight.

5.2.2 Make sure panel is supported on a clean surface when making cuts to minimize the risk of blemishes or melting on the cut face.

5.2.3 It is recommended that the same blade is not used when cutting panels that have different colors in order to minimize the risk of transferring colored fibers between panels.

5.2.3.1 If you only have one blade, mineral spirits (or other similar solvents) can be used to clean the blade with steel wool.

5.2.4 Make sure the blade is kept clean and sharp to insure optimal cuts.

5.2.5 If a slice cut is needed in the middle of a panel to work around an object in the plenum, you can insert a small piece of scrap hanger wire through the two pieces of panel on either side of the cut to add stability to the cut and minimize any possibility of sagging. **(Fig 22)**

5.2.6 Modifying hardware spacing if panels are cut in the field

- FELTWORKS® Acoustical Panels can be cut to length in the field, as long as the panels follow the same attachment rules as specified, and the panels are supported within 9" of the edges.
- A panel smaller than 48" x 96" should have one attachment point for every 4 SF, regardless of the installation method. Always round up if the calculation creates a partial attachment point. The attachment points should be uniformly spaced.
- If a slice cut is needed in the middle of a panel to work around an object in the plenum, make sure an attachment point is within 9" from the edge of the slice cut.

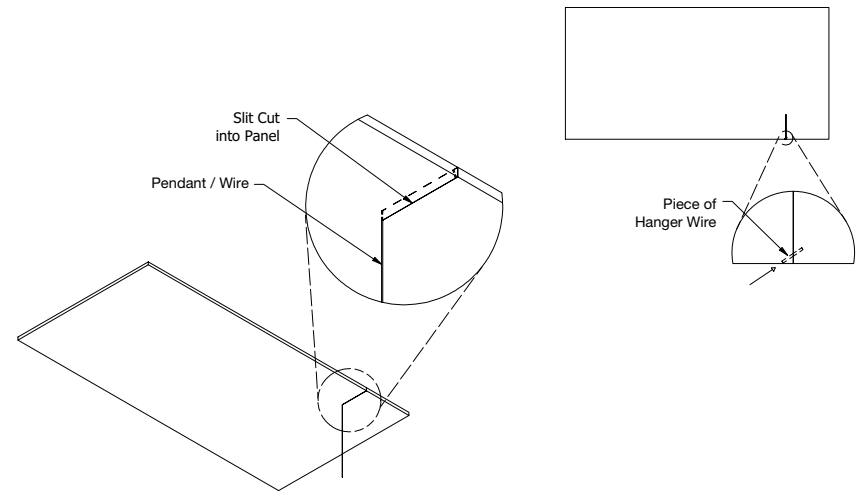

(Fig 22)

5.3 Directionality

There is a natural fiber direction in the FELTWORKS Acoustical Panels. It is recommended to install the panels in the same fiber direction. Directionality will be marked with an arrow on the back of the panels.

6. SPECIAL INSTALLATION CONSIDERATIONS

6.1 Sloped Applications

A sloped installation can be used with the Direct-Attached (screw and washer) installation method only. The maximum ceiling slope shall not exceed 30°.

The Magnet and Direct-Applied (adhesive) installation methods are not recommended for sloped installations at this time. Please refer to our "*Sloped Ceilings Technical and Installation Guide*" for more information on sloped applications.

6.2 Pools/Natatoriums

FELTWORKS Acoustical Panels are not to be used in pool areas.

6.3 Exterior Applications

FELTWORKS Acoustical Panels are not intended for use in exterior applications.

7. SEISMIC INSTALLATIONS

7.1 FELTWORKS Acoustical Panels have been engineered and tested for application in all Seismic Design Categories when installed following these instructions.

7.2 Grid Suspension System

- All seismic installations of FELTWORKS Acoustical Panels must be installed per Seismic Categories D, E, and F. This is regardless of the total system weight.
- Prelude® XL® Heavy-duty grid is required per ASTM E580 and the cross tees may have to match the mains in load-carrying capacity based on the grid layouts.
- FELTWORKS Acoustical Panels directly attached to grid have been engineered for application in all seismic areas.

7.3 Seismic Rx® Category D, E, and F Requirements (All Seismic Installations)

- Ceiling installation should conform to basic minimums established in ASTM C636.
- Minimum 7/8" wall molding.
- Suspension system must be attached on two adjacent walls.
- Opposite walls require BERC2 with 3/4" clearance.
- BERC2 clip maintains main beam and cross tee spacing, no other components required.
- Heavy-duty systems as identified in ICC-ESR-1308.
- Safety wires required on light fixtures.
- Perimeter support wires within 8" of perimeter.
- Ceiling areas over 1,000 SF must have horizontal restraint wire or rigid bracing.
- Ceiling areas over 2,500 SF must have seismic separation joints or full height partitions.
- Ceilings without rigid bracing must have 2" oversized trim rings for sprinklers and other penetrations.
- Changes in ceiling plane must have positive bracing.
- Cable trays and electrical conduits must be independently supported and braced.
- Suspended ceilings will be subject to special inspection.
- Connection to wall: See BPCS-4141 *Seismic Design: What You Need to Know – Code Requirements Seismic Rx® Tested Solutions – Seismic Rx Approaches to Category C and D, E, And F Installations*.
- Special bracing required: See BPCS-4141 *Seismic Design: What You Need to Know – Code Requirements Seismic Rx® Tested Solutions – Bracing and Restraint for Seismic Installations*.
- Seismic separation joints: See BPCS-4141 *Seismic Design: What You Need to Know – Code Requirements Seismic Rx® Tested Solutions – Seismic Separation Joints*.
- Seismic installations of FELTWORKS® Acoustical Panels are to be handled per building code. Please check with your local code official to see if any additional requirements are needed.

Item No.	Description	Included with Panels	Sold by the	Pcs / SF	Lbs. /SF
FELTWORKS® ACOUSTICAL PANELS					
8246FBL	FELTWORKS® Acoustical Panel – Black – 48 x 96 x 1"	–	Pallet	35 pcs / 1120 sq.ft.	0.50
8246FWH	FELTWORKS Acoustical Panel – White – 48 x 96 x 1"	–	Pallet	35 pcs / 1120 sq.ft.	0.50
8246FLG	FELTWORKS Acoustical Panel – Light Grey – 48 x 96 x 1"	–	Pallet	35 pcs / 1120 sq.ft.	0.50
8246FDG	FELTWORKS Acoustical Panel – Dark Grey – 48 x 96 x 1"	–	Pallet	35 pcs / 1120 sq.ft.	0.50
8246FBG	FELTWORKS Acoustical Panel – Beige – 48 x 96 x 1"	–	Pallet	35 pcs / 1120 sq.ft.	0.50
ACCESSORIES				Quantity	
6488MF	Washers – Mill Finish (paintable)	No	Pail	1000	–
6488BL	Washers – Black Finish	No	Pail	1000	–
6489MF	#8 x 1-7/8" Screws for washer installation – Mill Finish (paintable)	No	Pail	1000	–
6489BL	#8 x 1-7/8" Screws for washer installation – Black Finish	No	Pail	1000	–
6526	Magnets	No	Ctn	120	–
6527	#8 x 1" Screws for magnet installation	No	Pail	1000	–
–	Original Gorilla Glue®	No	Not sold by Armstrong® Ceilings		
–	Titebond® GREENchoice Acoustical Ceiling Tile Adhesive	No	Not sold by Armstrong Ceilings		
–	Henry® 237 AcoustiGum™ Acoustical Ceiling Tile Adhesive	No	Not sold by Armstrong Ceilings		
–	Notched Trowel – 1/4 x 1/2 x 1/4"	No	Not sold by Armstrong Ceilings		
–	Sponge Float	No	Not sold by Armstrong Ceilings		
SUSPENSION SYSTEM COMPONENTS				Quantity	
HD8906	12' HD Drywall Grid Main Beam	No	Ctn	12	–
XL8945	4' Drywall Grid Cross Tee	No	Ctn	36	–
QSUTC	QuikStix™ Uptight Clip	No	Ctn	150	–
–	Galvanized Steel Furring Channel	No	Not sold by Armstrong Ceilings		
–	Wood Furring	No	Not sold by Armstrong Ceilings		

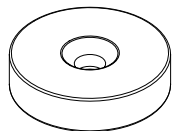

6526 Magnet

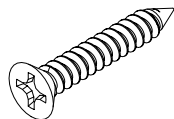

6527 #8 x 1" Screw
for magnet installation

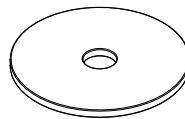

6488 Washer

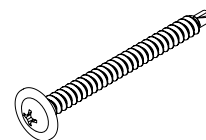

6489 #8 x 1-7/8" Screw
for washer installation

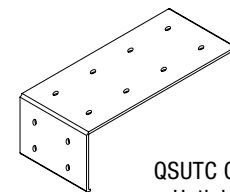

QSUTC QuikStix
Uptight Clip

MORE INFORMATION

For more information, or for an Armstrong Ceilings representative, call 1 877 276 7876.

For complete technical information, detail drawings, CAD design assistance, installation information, and many other technical services, call TechLine customer support at 1 877 276 7876 or FAX 1 800 572 TECH.

Gorilla Glue® is a trademark of Gorilla Glue Company; Henry® and AcoustiGum™ are trademarks of W.W. Henry Company; Titebond® is a trademark of Franklin International; Inspiring Great Spaces® is a registered trademark of AFI Licensing LLC; All other trademarks used herein are the property of AWI Licensing LLC and/or its affiliates.

© 2020 AWI Licensing Company Printed in the United States of America

BPLA-299397-420

Armstrong®
CEILING & WALL SOLUTIONS