

Calla[®] Health Zone[™] AirAssure and Ultima[®] Health Zone[™] AirAssure

Assembly and Installation Instructions

1. GENERAL

1.1 Product Description

Ultima[®] Health Zone[™] AirAssure and Calla[®] Health Zone[™] AirAssure Tegular ceiling panels with integrated AirAssure gasket reduce air leakage through the ceiling plane up to 4x compared to ceiling panels without a gasket. AirAssure Panels can be installed on Armstrong 15/16" and 9/16" Suspension Systems. (Fig 1)

2. INSTALLATION LAYOUT

2.1 Grid Layout

2.1.1 Suspension systems, whether 9/16" or 15/16", shall be installed to meet the minimum requirements established in the ASTM C636 standard, and any other requirements established by local code.

2.1.2 Standard 2' x 2' (Fig 2)

- Main beams spaced 48" O.C.
- 4' cross tees shall intersect the main beams at 90° every 24" O.C.
- 2' cross tees shall be installed at the midpoints of the 4' cross tees, creating 24" x 24" modules.

2.2 Room Layout

Proper layout within a space is crucial for a good installation. Some layouts may have a starting point established by the architect noted on the prints. Examples of starting points may be for a specific border dimension, full size borders, or referenced from lights or columns. It is important to check the project plans before installation.

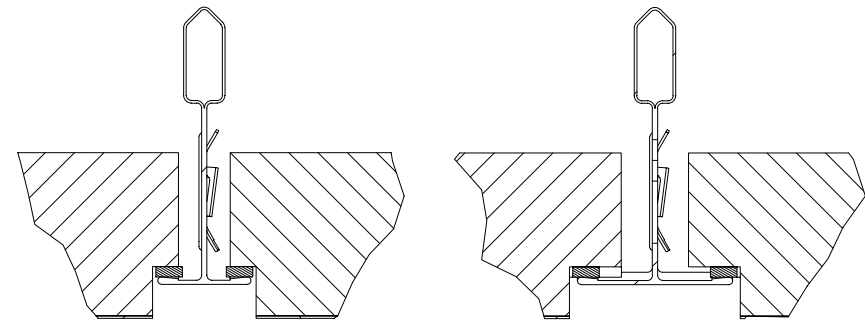

9/16" Grid Detail

15/16" Grid Detail

(Fig 1)

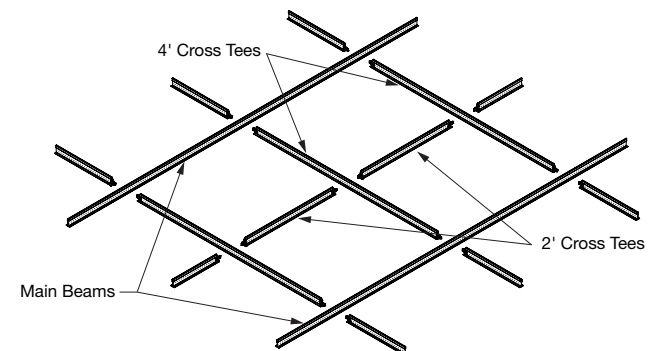

(Fig 2)

2.2.1 Calculating Equal Borders

The most pleasing visual is achieved when the border panels are no less than 10" wide, and the opposite wall has the exact same size border panel achieving proper room balance. For installations that require equal borders, the following steps will help you layout an installation with equal borders on opposite sides of the space.

- Determine the direction of the main beams and panel length.
- Divide each dimension of the space (length and width) by the panel length in that direction.

Ex: 28' 9" (room width) / 2' (panel width) = 14 full size panels and a 9" remainder

- Divide the remainder to get even opposite border panels. If this results in border panels less than 10" you will need to add a full panel to the remainder so that the border panels are greater than 10".

Ex: 9" (remainder) / 2 (borders) = 4-1/2" border (too small)

24" (full panel width) + 9" = 33" (new remainder)

33" / 2 (borders) = 16-1/2" borders with 13 full size panels

2.3 Plenum

Allow at least 3" below the old ceiling, duct work, pipes, or wiring as clearance to maneuver a ceiling panel into the opening of the grid.

3. PANEL INSTALLATION

3.1 Tegular panels will have a step cut out around the edge of the panel. They will install above the grid, with the AirAssure Sealing Tape resting on the flange of the grid (*Fig 3*).

3.2 Perimeter Treatment

3.2.1 Perimeter panels less than full size shall be installed by recutting the Tegular edge detail and reinstalling the AirAssure Sealing Tape on the new field cut Tegular edge.

3.2.2 Installer will need separate roll of AirAssure Sealing Tape (Item 1350) for reinstallation on the cut panel.

3.2.3 Cut the panel and the new Tegular edge with a utility knife. Blow and brush off dust and residue from the new Tegular edge to ensure a clean surface to apply the new sealing tape.

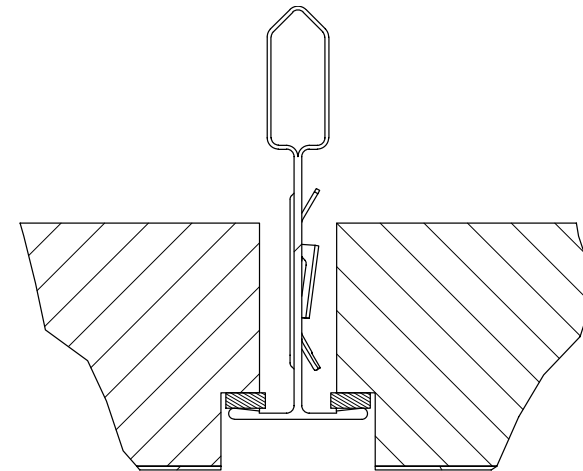

9/16" Grid Detail

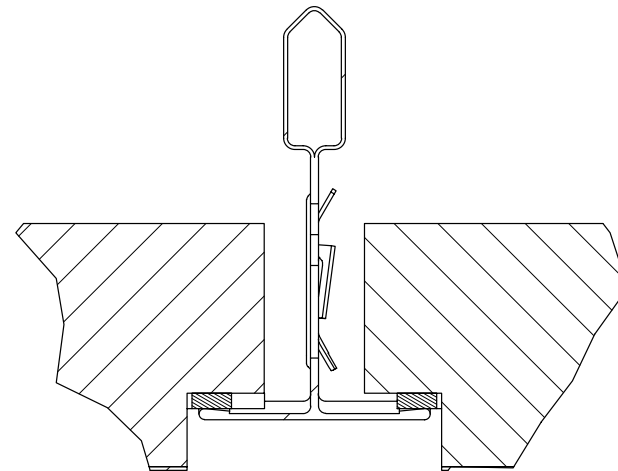

15/16" Grid Detail

(Fig 3)

3.2.4 Once the perimeter panel is cut and the new Tegular edge is created, position the new AirAssure Sealing Tape tight to the Tegular corner. Trim the sealing tape flush with the back cut. Do not overlap sealing tape joints (*Fig 4*). AirAssure Sealing Tape cuts best with scissors or snips.

3.2.5 Apply pressure to the entire sealing tape surface to assure proper bond with the panel substrate. Apply on a clean, flat surface to not damage the field cut Tegular edge.

3.2.6 All field-cut edges "exposed to view" should be colored to match the factory finish. Armstrong SuperCoat Ceiling Panel Touch-up Paint is recommended.

3.2.7 An all-purpose silicone caulk or acoustical caulk can be used to fill any gaps around the perimeter to reduce air leakage points through the ceiling plane.

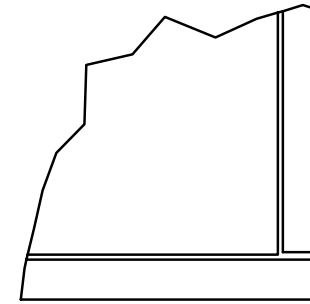

*9/16" Tegular
Corner Detail*

4. MEP INTEGRATION

AirAssure Gasketed Tiles that are integrated with any MEP must have the AirAssure Sealing Tape applied to the trim in order to reduce air leakage points through the ceiling plane.

5. SEISMIC

5.1 Installations occurring in seismic design categories C, D, E, or F must follow the methods described in the Seismic Design: What You Need to Know document. This document outlines the Armstrong Seismic Rx methods for installing suspended ceilings in compliance with the International Building Code (IBC) requirements for seismic design categories C, D, E, and F.

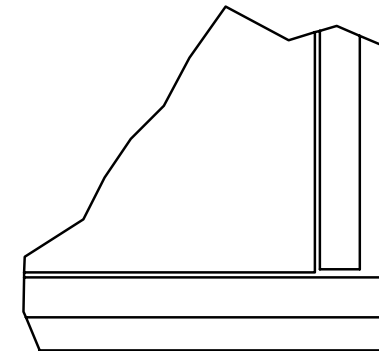

*15/16" Tegular
Corner Detail*

(Fig 4)

MORE INFORMATION

For more information, or for an Armstrong Ceilings representative, call 1 877 276 7876.

For complete technical information, detail drawings, CAD design assistance, installation information, and many other technical services, call TechLine customer support at 1 877 276 7876 or FAX 1 800 572 TECH.

All trademarks used herein are the property of AWI Licensing LLC and/or its affiliates.

© 2020 AWI Licensing LLC Printed in the United States of America